



US00D772767S

(12) **United States Design Patent** (10) **Patent No.:** **US D772,767 S**
Kim (45) **Date of Patent:** **** Nov. 29, 2016**

(54) **VEHICLE FRONT FASCIA**
(71) Applicant: **GM Global Technology Operations LLC, Detroit, MI (US)**
(72) Inventor: **Hoon S. Kim, Troy, MI (US)**
(73) Assignee: **GM Global Technology Operations LLC, Detroit, MI (US)**

D609,608 S 2/2010 Boniface et al.
D611,387 S 3/2010 Thompson et al.
D611,879 S 3/2010 Kim et al.
D612,297 S 3/2010 Peters et al.
D613,645 S 4/2010 Song et al.
D615,458 S 5/2010 Thompson et al.
D618,595 S 6/2010 Ware et al.
D623,090 S 9/2010 Cox et al.
D627,262 S 11/2010 Ikeda et al.
D633,013 S * 2/2011 Bauer D12/169

(**) Term: **15 Years**

(Continued)

(21) Appl. No.: **29/539,780**

OTHER PUBLICATIONS

(22) Filed: **Sep. 17, 2015**

“2016 Cadillac CT6—2015 New York Auto Show.” YouTube.com. 1:10. Published Apr. 1, 2015. Accessed Aug. 1, 2016. Available online at URL: <<https://www.youtube.com/watch?v=Mzfk6DLM-cc>>.*

(51) **LOC (10) Cl.** **12-08**

(52) **U.S. Cl.**
USPC **D12/169**

(Continued)

(58) **Field of Classification Search**
USPC D12/86–92, 163–172; 293/102–155;
296/35.2, 193.09, 193.1, 203.02
CPC B60R 19/02; B60R 19/023; B60R 19/18;
B60R 19/24; B60R 19/44; B60R 19/48;
B60R 19/56; B60R 2019/527; B60R
2019/1886
See application file for complete search history.

Primary Examiner — Cathron Brooks
Assistant Examiner — Christian P McLean
(74) *Attorney, Agent, or Firm* — Reising Ethington P.C.

(57) **CLAIM**
The ornamental design for a vehicle front fascia, as shown and described.

(56) **References Cited**

DESCRIPTION

U.S. PATENT DOCUMENTS

D570,742 S 6/2008 Takagi et al.
D592,105 S 5/2009 Dean et al.
D597,447 S 8/2009 Folden
D600,595 S 9/2009 Nakamura et al.
D601,925 S 10/2009 O’Donnell
D603,755 S 11/2009 Peters
D604,203 S 11/2009 O’Donnell
D605,082 S 12/2009 Munson
D605,083 S 12/2009 Manoogian, II et al.
D605,977 S 12/2009 Zipfel et al.
D605,978 S 12/2009 Wolff et al.
D608,249 S 1/2010 Peters
D608,690 S 1/2010 Folden et al.
D608,691 S 1/2010 Zak, Jr. et al.

FIG. 1 is a perspective view of the vehicle front fascia; FIG. 2 is a left side elevation view thereof; FIG. 3 is a top plan view thereof; and, FIG. 4 is a front view thereof.
The right side elevation view of the vehicle front fascia is omitted because the right side elevation view is identical to the left side elevation view with the exception that the right side elevation view would depict the polygonal-like broken-line feature shown in FIGS. 1 and 4. And the broken lines shown in the drawings depict portions of the vehicle front fascia that form no part of the claimed design.

1 Claim, 2 Drawing Sheets

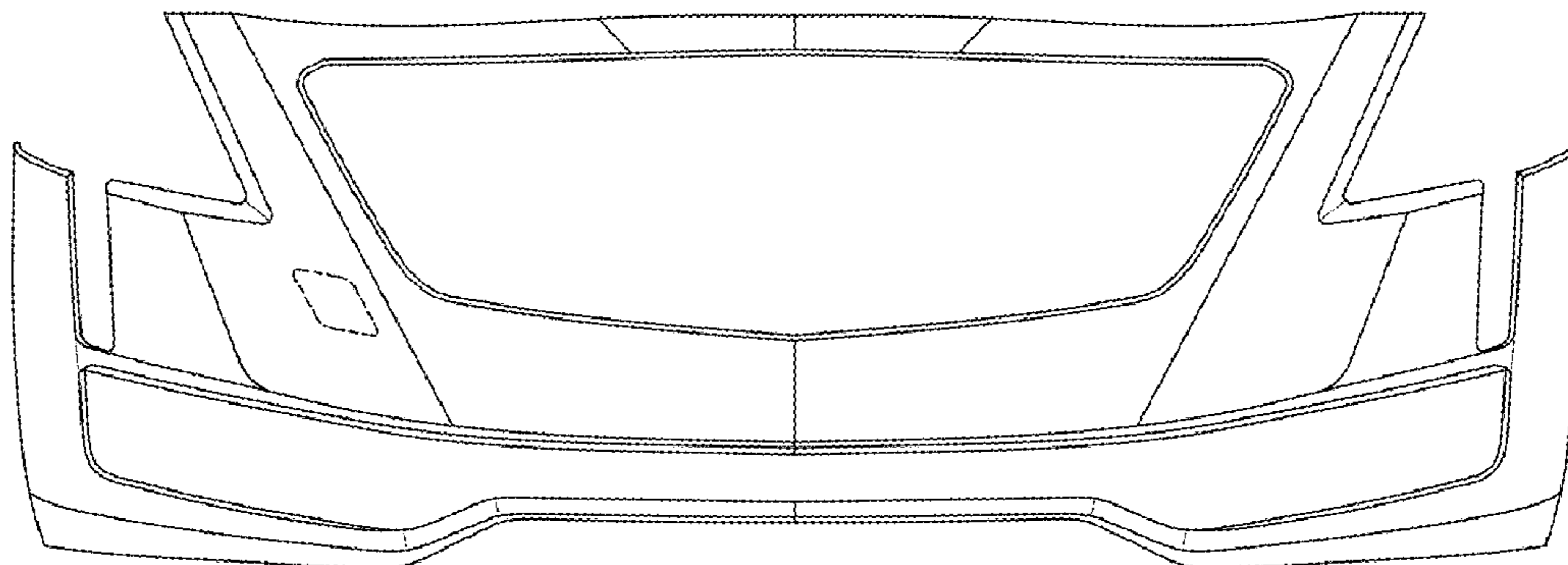

(56)

References Cited

U.S. PATENT DOCUMENTS

D635,488 S 4/2011 Phipps
 D644,147 S 8/2011 Suh et al.
 D644,567 S 9/2011 Kozub
 D657,718 S 4/2012 Zipfel et al.
 D659,052 S 5/2012 Ware et al.
 D659,053 S 5/2012 Ware et al.
 D668,182 S 10/2012 Franco et al.
 D668,183 S 10/2012 Smart
 D668,189 S * 10/2012 Gifford D12/169
 D678,820 S 3/2013 Son et al.
 D678,821 S 3/2013 Ikeda et al.
 D680,909 S 4/2013 Munson et al.
 D680,910 S 4/2013 David
 D684,899 S 6/2013 Baker
 D686,536 S 7/2013 McCabe et al.
 D692,798 S 11/2013 Thurber
 D692,799 S 11/2013 Smith et al.
 D696,157 S 12/2013 Loeb
 D699,629 S 2/2014 Ikeda et al.
 D700,871 S 3/2014 O'Donnell et al.
 D702,161 S * 4/2014 Hanaoka D12/169
 D703,103 S 4/2014 Lee
 D704,103 S 5/2014 Mack et al.
 D705,132 S 5/2014 Ware et al.
 D705,699 S 5/2014 Ware et al.
 D713,298 S 9/2014 Dyson
 D713,764 S 9/2014 Ferlazzo et al.
 D716,200 S * 10/2014 Pevovar D12/169
 D716,696 S 11/2014 Thole et al.
 D716,706 S 11/2014 Thole et al.
 D716,709 S 11/2014 Thole et al.

D717,696 S 11/2014 Thole et al.
 D718,189 S 11/2014 Krieg et al.
 D718,683 S 12/2014 Thole et al.
 D722,282 S 2/2015 Loeb
 D722,533 S 2/2015 Thole et al.
 D722,534 S 2/2015 Munson et al.
 D724,503 S * 3/2015 Hall D12/169
 D724,510 S 3/2015 McMahan et al.
 D725,001 S 3/2015 McMahan et al.
 D730,776 S 6/2015 Smart
 D730,783 S 6/2015 Henriques et al.
 D732,435 S 6/2015 Mackay
 D735,627 S 8/2015 Smith
 D736,451 S 8/2015 Smith
 D744,914 S * 12/2015 Loeb D12/169
 D745,837 S * 12/2015 Smith D12/169
 D749,021 S * 2/2016 Boniface D12/169
 D750,000 S * 2/2016 Han D12/169
 D753,034 S * 4/2016 Thole D12/169
 D753,561 S * 4/2016 Iwauchi D12/169
 D760,631 S * 7/2016 Choi D12/169

OTHER PUBLICATIONS

“Future Cars! 2016 and Beyond.” motortrend.com. May 6, 2015. Accessed Aug. 1, 2016. Available online at URL: <<http://www.motortrend.com/news/future-cars-3/>>.*
 Patterson, Justin. “2016 Cadillac CT6 release date, interior, cost.” carsintrend.com. Jun. 16, 2015. Accessed Aug. 1, 2016. Available online at URL: <<http://carsintrend.com/2016-cadillac-ct6-release-date-interior-cost/>>.*

* cited by examiner

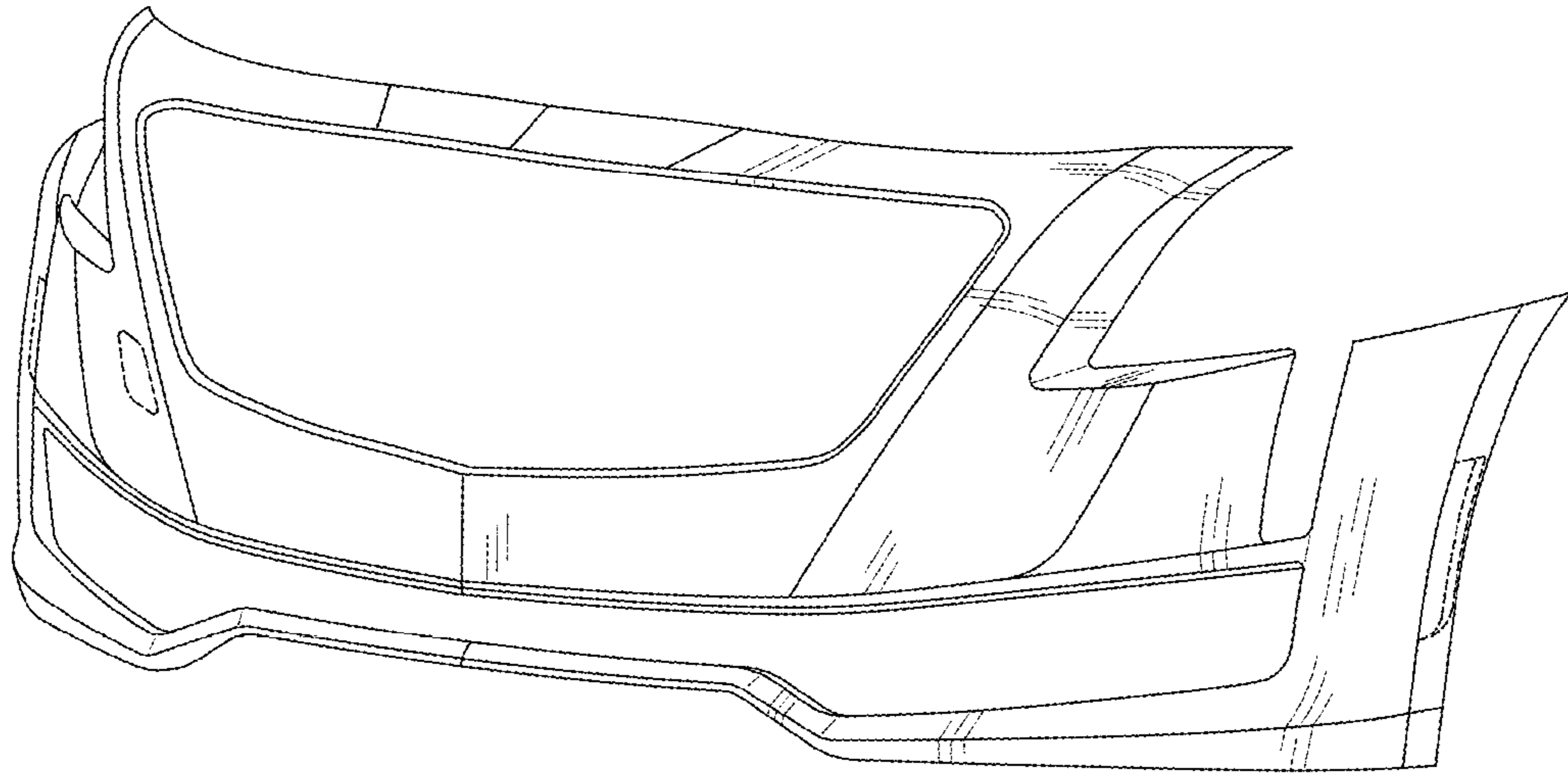

Fig. 1

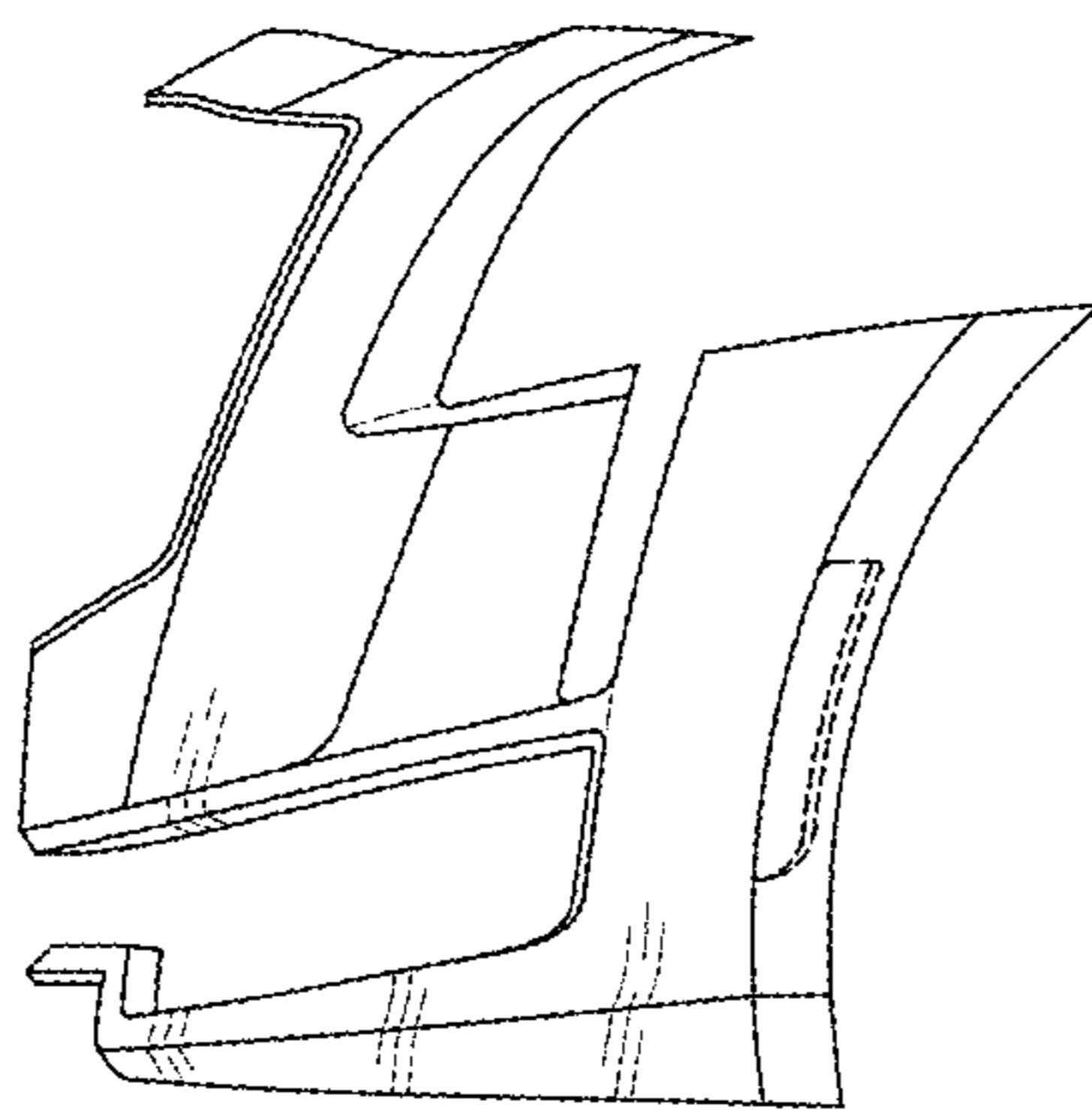

Fig. 2

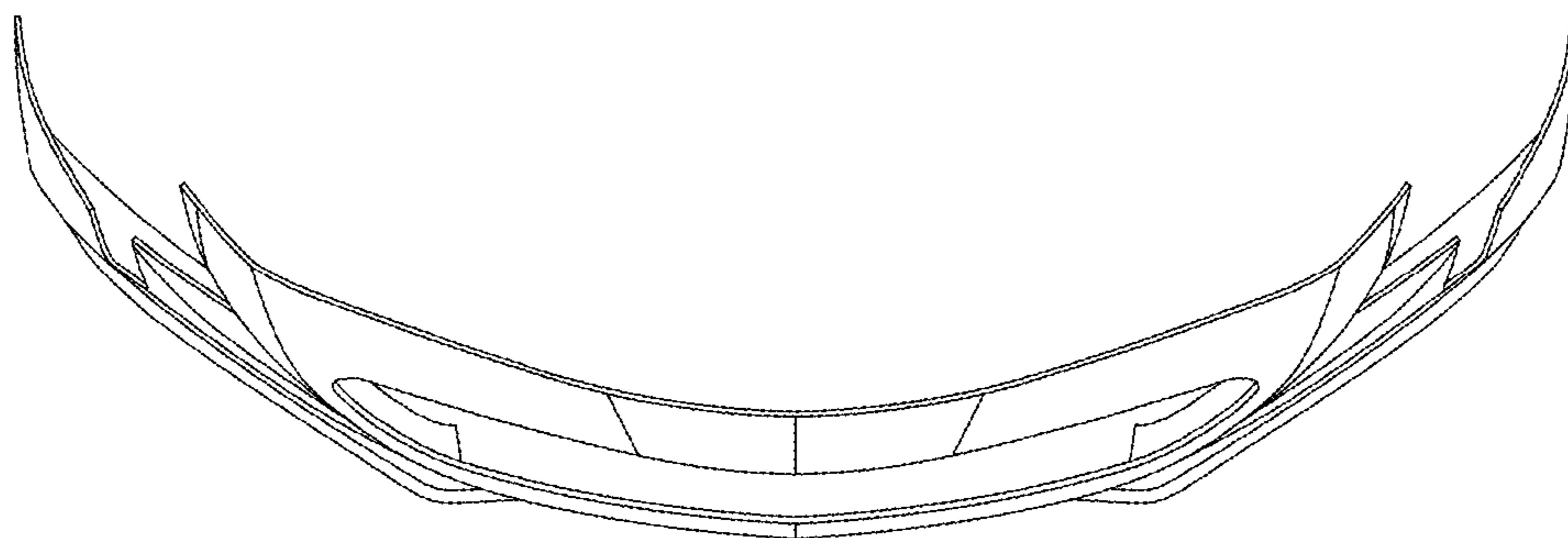

Fig.3

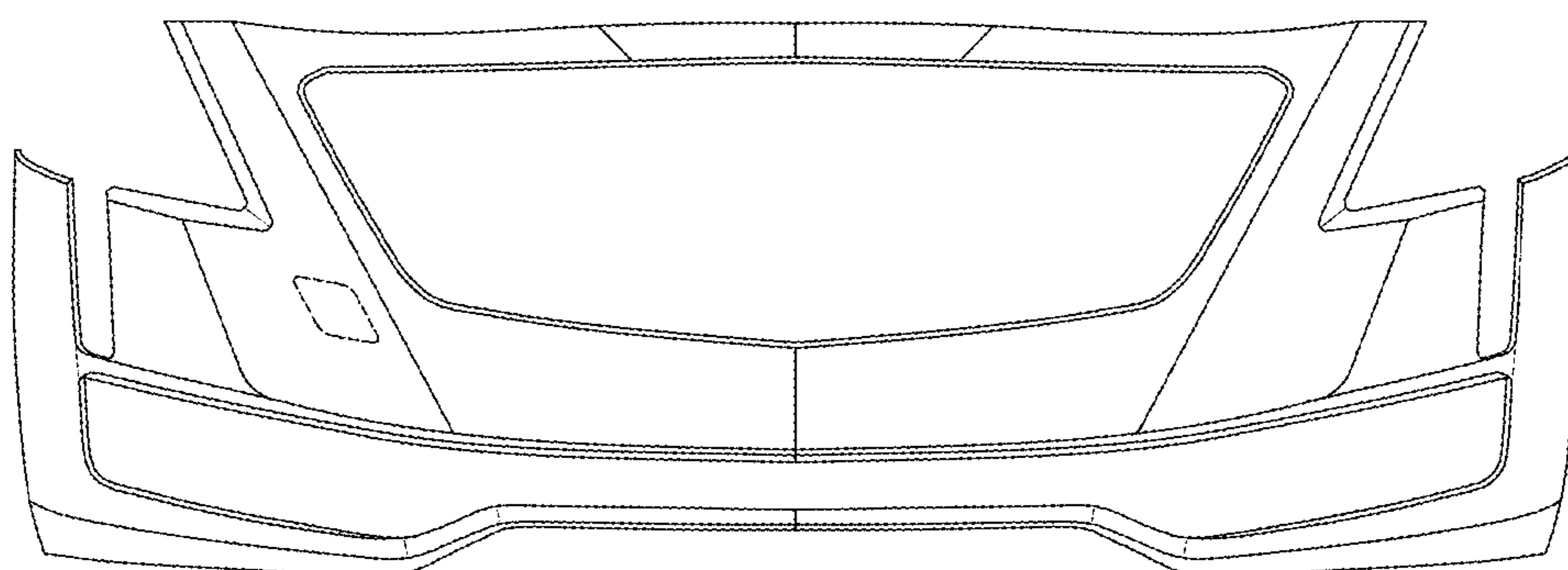

Fig.4