



US00D772719S

(12) **United States Design Patent** (10) **Patent No.:** **US D772,719 S**
Chelvaratnam (45) **Date of Patent:** **** Nov. 29, 2016**

(54) **KANGAROO BOTTLE**

(56) **References Cited**

(71) Applicant: **Aquarush Pty Ltd**, Campbellfield,
Victoria (AU)

U.S. PATENT DOCUMENTS

(72) Inventor: **Roshan Chelvaratnam**, Campbellfield
(AU)

D165,313 S * 11/1951 Walkley et al. D21/651
D176,837 S * 2/1956 Brautigam D21/651
D235,569 S * 6/1975 De Fina D21/651
4,736,847 A * 4/1988 Wang A63H 3/005
206/457
D421,716 S * 3/2000 Indelicato D9/607

(73) Assignee: **AQUARUSH PTY LTD.**,
Campbellfield, Victoria (AU)

* cited by examiner

(**) Term: **14 Years**

Primary Examiner — Sandra Morris

(21) Appl. No.: **29/525,323**

(74) *Attorney, Agent, or Firm* — John Alunit

(22) Filed: **Apr. 29, 2015**

(57) **CLAIM**

I claim the ornamental design for a kangaroo bottle, as shown and described herein.

(30) **Foreign Application Priority Data**

DESCRIPTION

Oct. 29, 2014 (AU) 358716

FIG. 1 is a front view of a kangaroo bottle according to the new design.

(51) **LOC (10) Cl.** **09-01**

FIG. 2 is a left side view of the kangaroo bottle according to the new design.

(52) **U.S. Cl.**

USPC **D9/607**; D9/601

FIG. 3 is a back view of the kangaroo bottle according to the new design.

(58) **Field of Classification Search**

USPC D9/600–601, 607–613; 206/457, 494,
206/459.5, 527, 540; 229/116.1; 446/77;
215/381–384, 400; D7/514–516, 539,
D7/544, 571, 579, 604, 613, 619.2,
D7/628–630, 391–392.1; D3/270–271.3;
D21/651

FIG. 4 is a top view of the kangaroo bottle according to the new design.

FIG. 5 is a right side view of the kangaroo bottle according to the new design.

CPC B65D 67/00; B65D 81/36; B65D 81/60;
B65D 81/368; B65D 2203/00; B65D
2203/02; A63H 33/16

FIG. 6 is a bottom view of the kangaroo bottle according to the new design.

FIG. 7 is a rear perspective view of the kangaroo bottle according to the new design; and,

FIG. 8 is a front perspective view of the kangaroo bottle according to the new design.

See application file for complete search history.

1 Claim, 8 Drawing Sheets

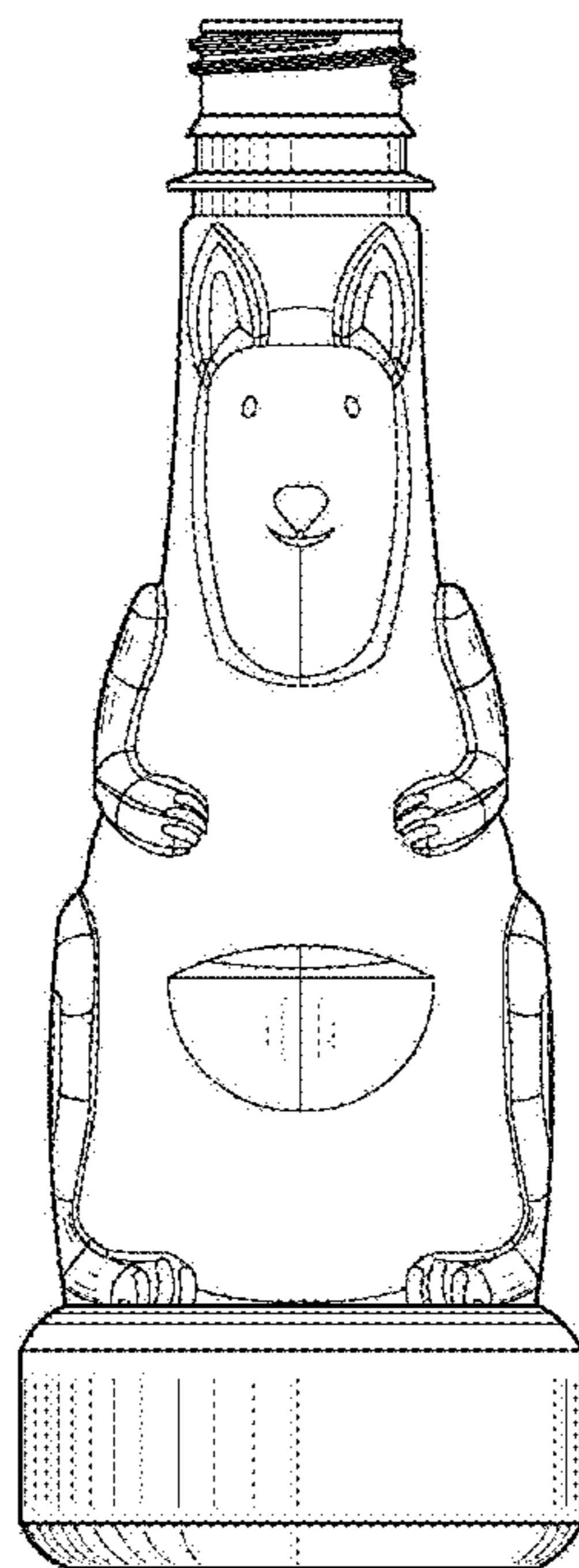

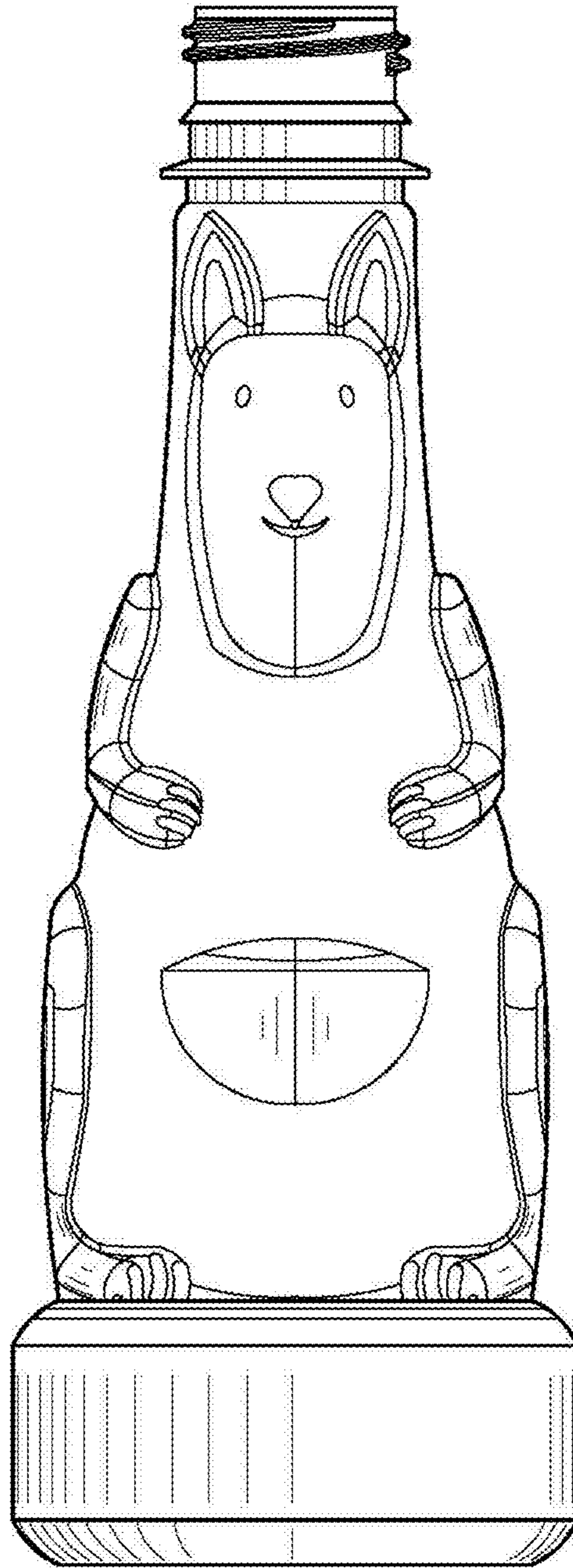

Fig. 1

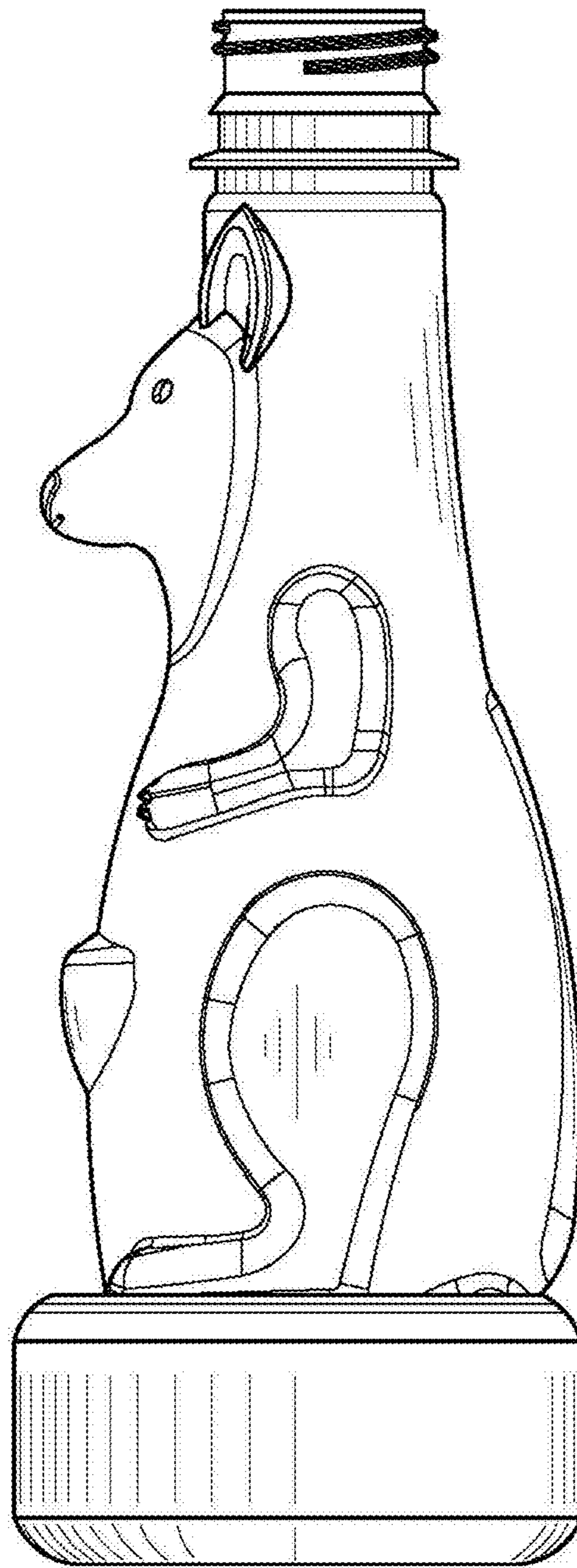

Fig.2

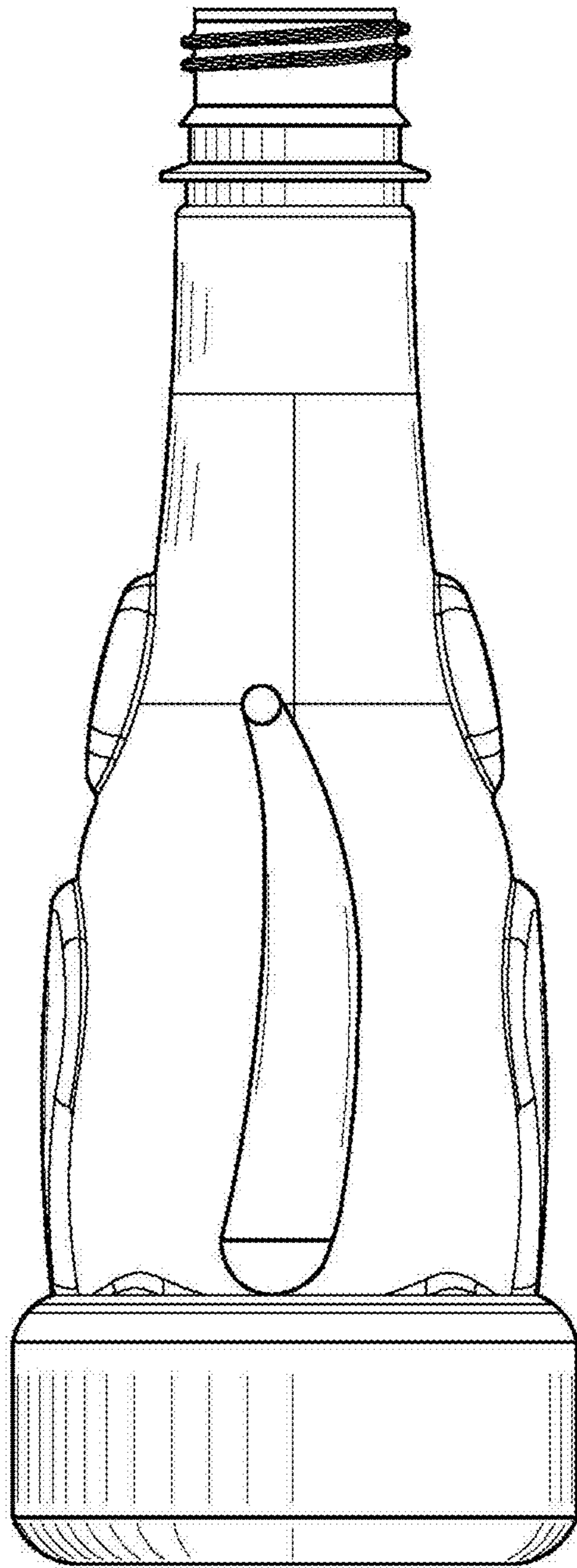

Fig.3

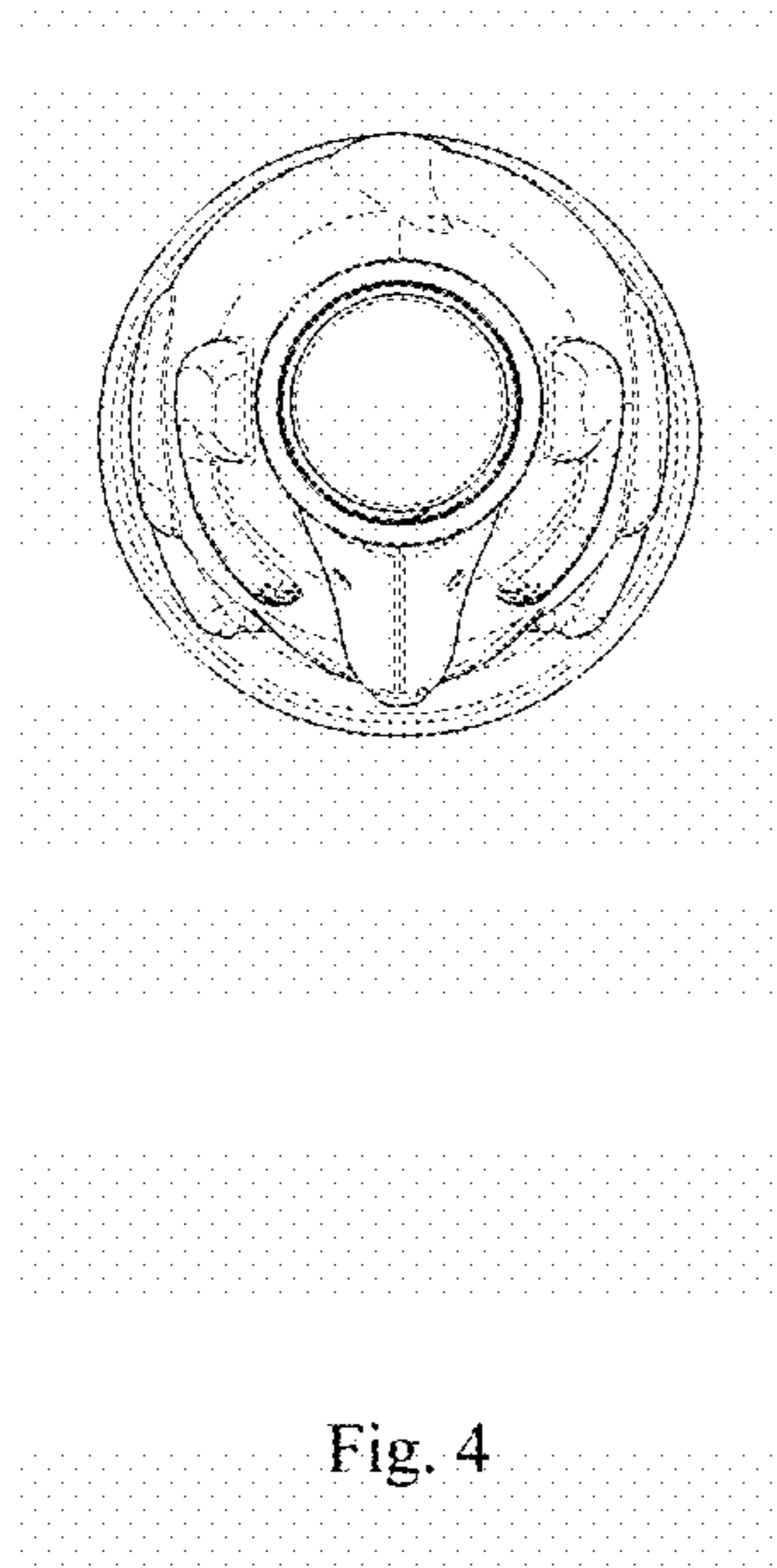

Fig. 4

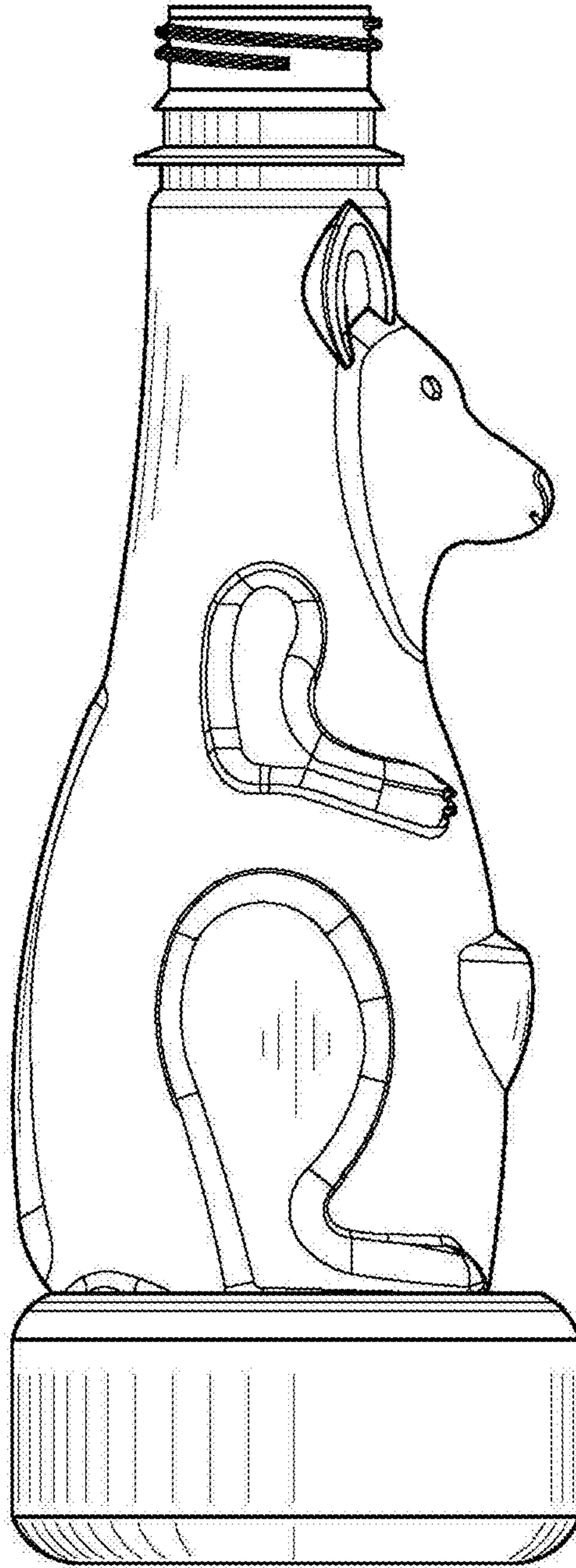

Fig.5

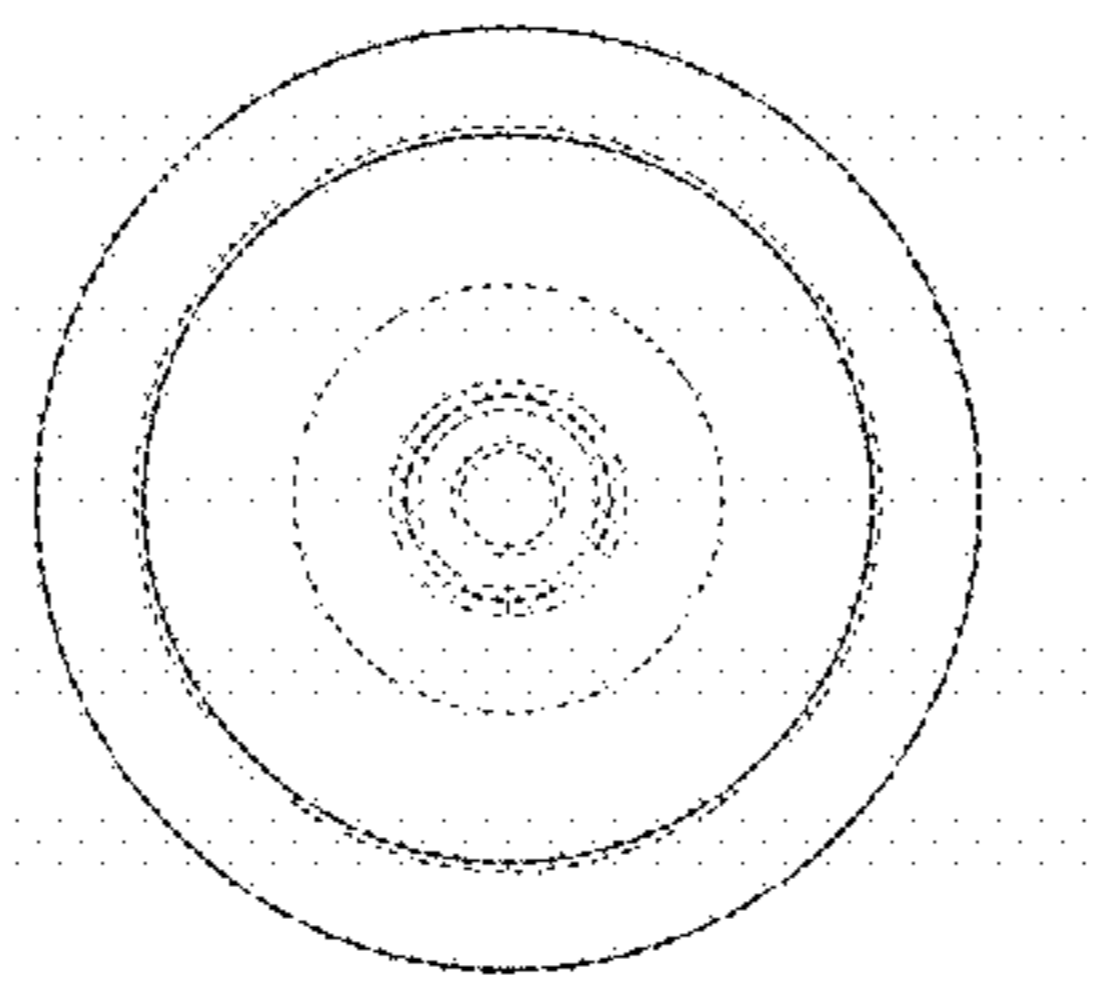

Fig. 6

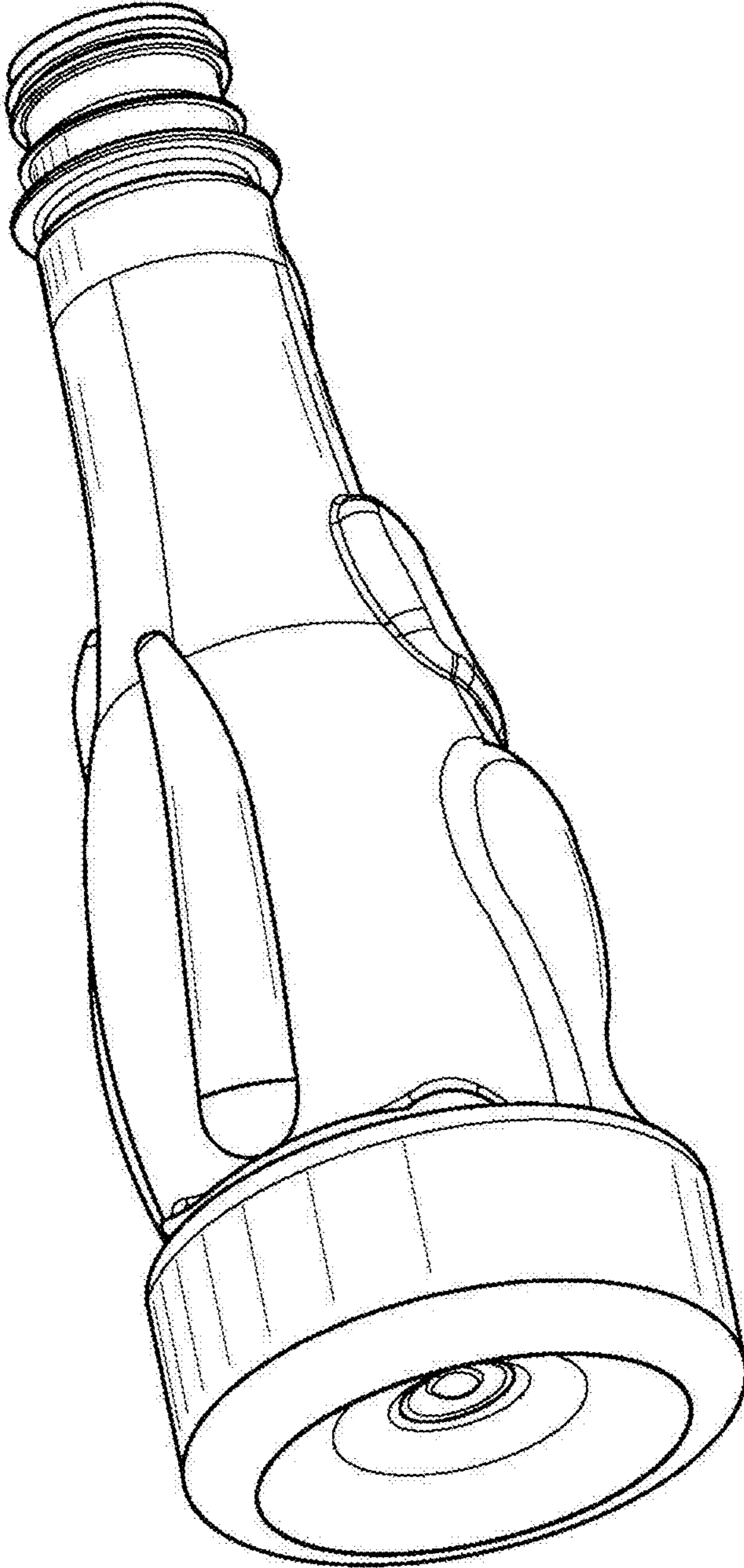

Fig. 7

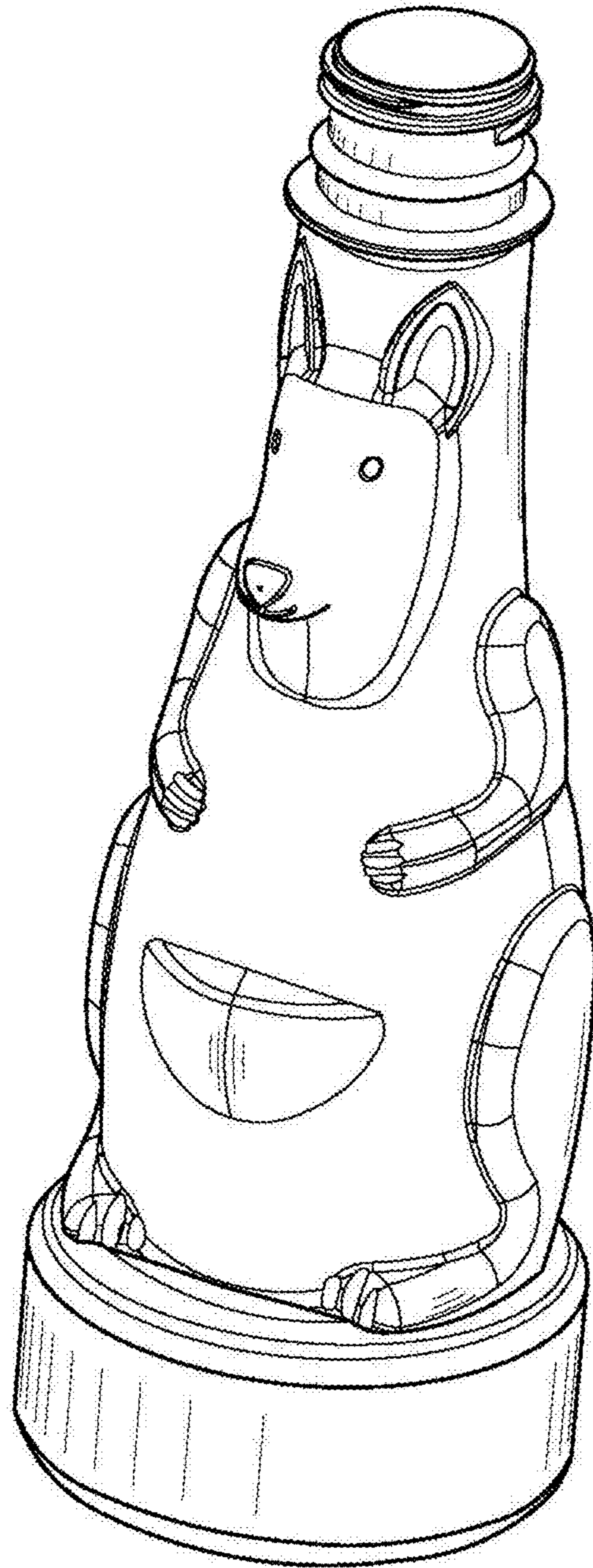

Fig.8