



US00D772332S

(12) **United States Design Patent** (10) **Patent No.:** **US D772,332 S**
Mordechay (45) **Date of Patent:** **** Nov. 22, 2016**

(54) **COMBINED GUITAR HEADSTOCK AND NECK**

(71) Applicant: **Hanoch Hanoka Mordechay,**
Mevaseret Zion (IL)

(72) Inventor: **Hanoch Hanoka Mordechay,**
Mevaseret Zion (IL)

(**) Term: **15 Years**

(21) Appl. No.: **29/533,574**

(22) Filed: **Jul. 20, 2015**

Related U.S. Application Data

(62) Division of application No. 29/476,116, filed on Dec. 11, 2013, now Pat. No. Des. 754,784.

(30) **Foreign Application Priority Data**

Jun. 11, 2013 (IL) 54150
Jun. 11, 2013 (IL) 54151
Jun. 11, 2013 (IL) 54152

(51) **LOC (10) Cl.** **17-03**

(52) **U.S. Cl.**
USPC **D17/20**

(58) **Field of Classification Search**
USPC D11/108; D17/14, 20; D26/94; 84/294,
84/297 R, 299, 307, 314 R, 485 R, 726
CPC G10D 1/085; G10D 3/06
See application file for complete search history.

(56) **References Cited**

U.S. PATENT DOCUMENTS

D160,642 S *	10/1950	Mantzowitz	D11/108
D165,127 S *	11/1951	Zoss	D11/122
D178,329 S *	7/1956	Weisberg	D11/122
D210,553 S *	3/1968	Wilkerson	D26/94
D224,050 S *	6/1972	Guadio	D17/19
D250,518 S *	12/1978	Friedman	D11/108
D254,378 S *	3/1980	Whitesel, II	D17/18
D313,810 S *	1/1991	Walker	D17/14
D331,252 S *	11/1992	Kroptavich	D17/18
D367,436 S *	2/1996	Bloch	D11/108
D572,166 S *	7/2008	Freer-Heeter	D11/108

* cited by examiner

Primary Examiner — Robert M Spear

Assistant Examiner — Darcey E Heflin

(74) *Attorney, Agent, or Firm* — Ostrolenk Faber LLP

(57) **CLAIM**

I claim the ornamental design for combined guitar headstock and neck, as shown and described.

DESCRIPTION

FIG. 1 is a perspective of a combined guitar headstock and neck of the present invention.

FIG. 2 is a perspective of a combined guitar headstock and neck of the present invention.

FIG. 3 is a front view of the guitar of FIG. 1.

FIG. 4 is a back view of the guitar of FIG. 1.

FIG. 5 is a first side view of the guitar of FIG. 1.

FIG. 6 is an opposite side view of the guitar of FIG. 1.

FIG. 7 is a top view of the guitar of FIG. 1; and,

FIG. 8 is a bottom view of the guitar of FIG. 1.

1 Claim, 8 Drawing Sheets

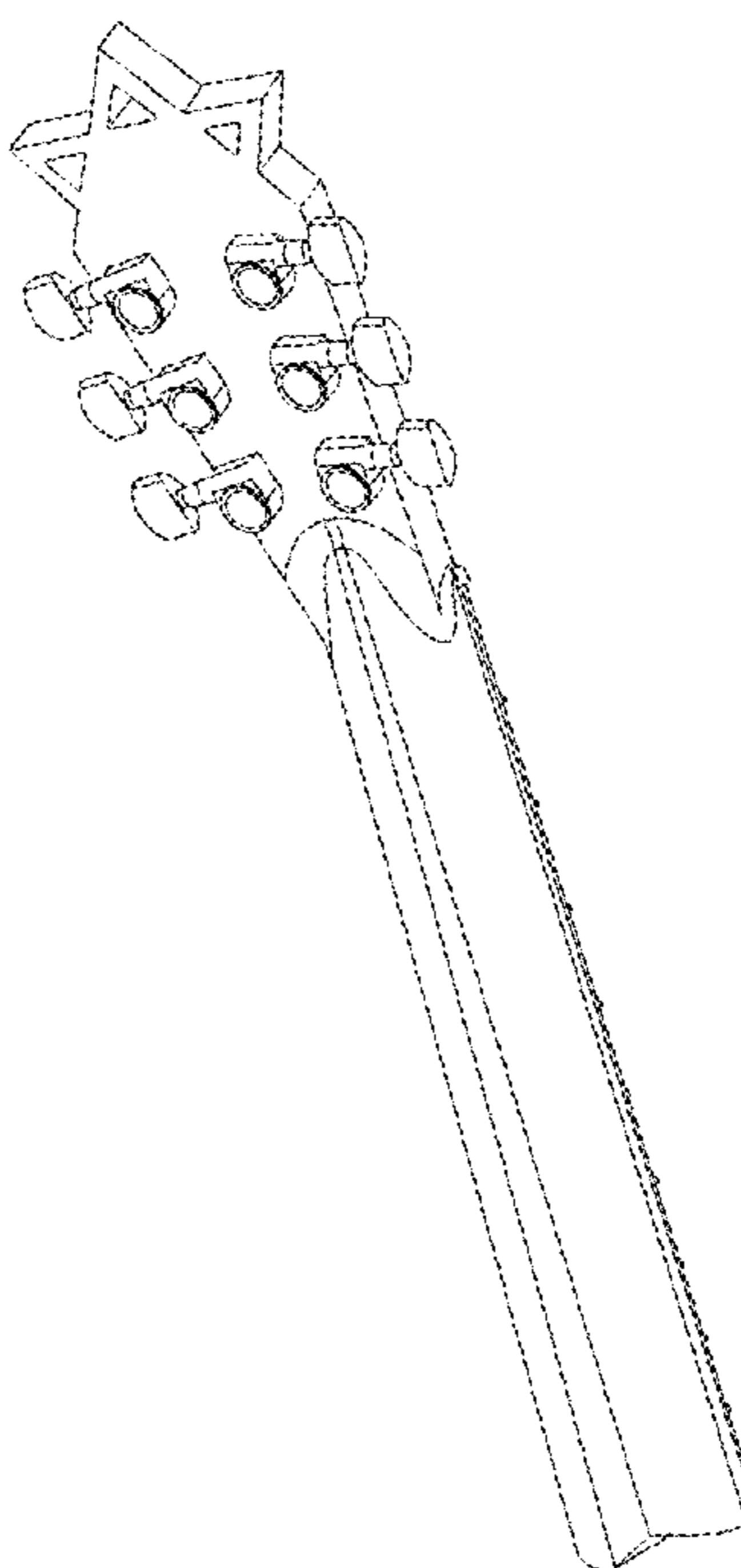
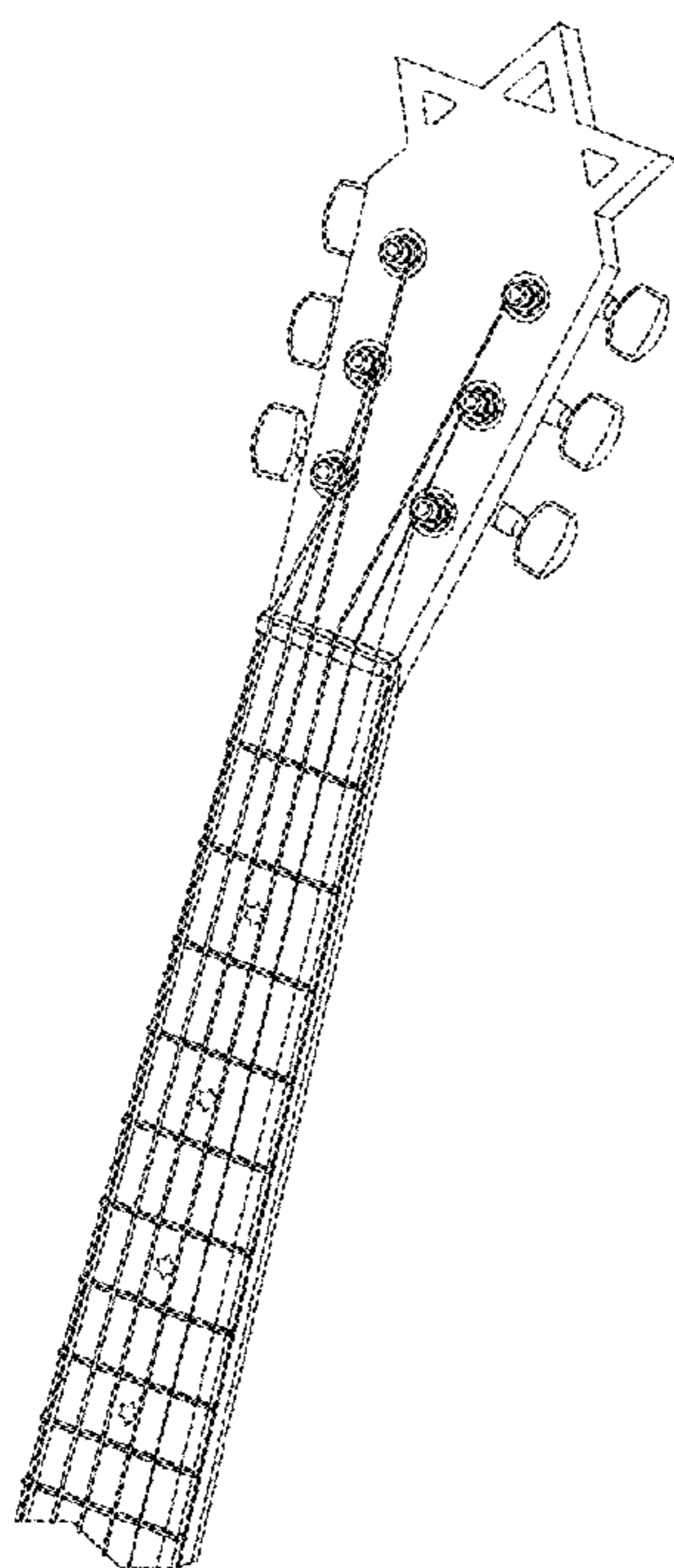
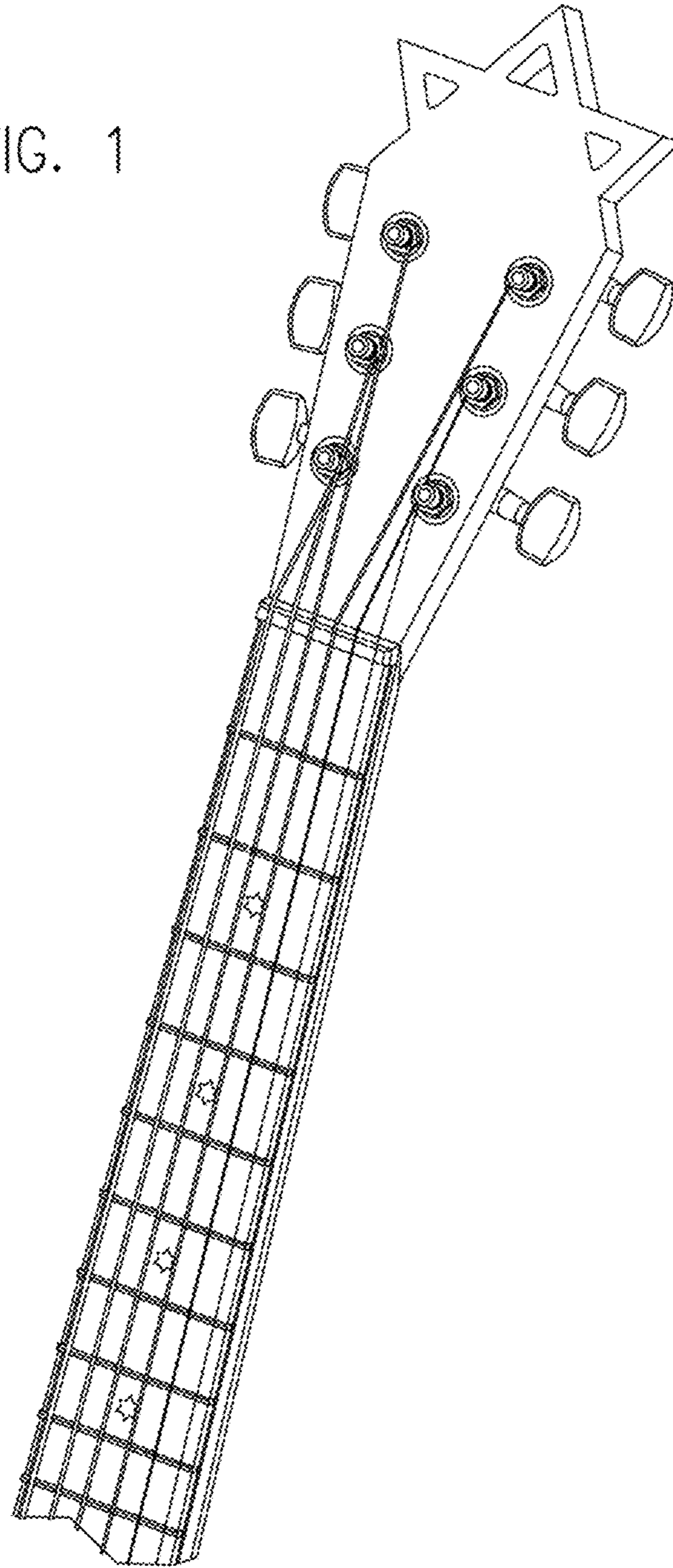

FIG. 1



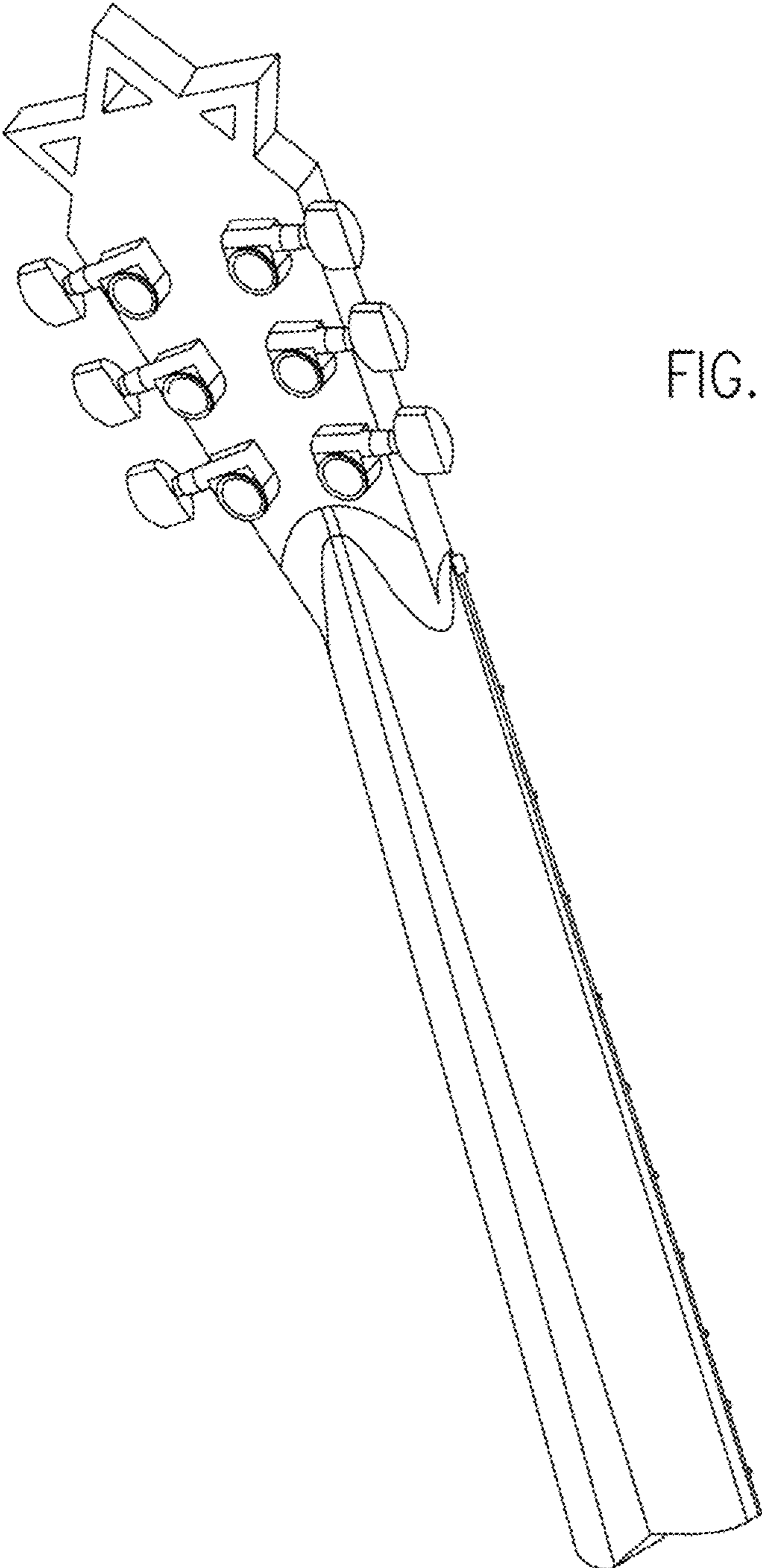

FIG. 2

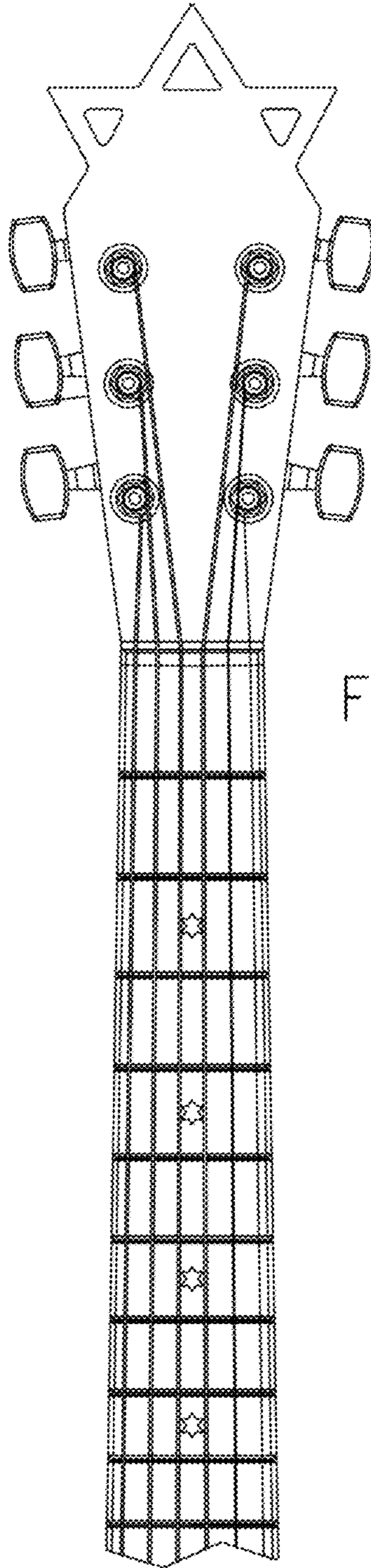

FIG. 3

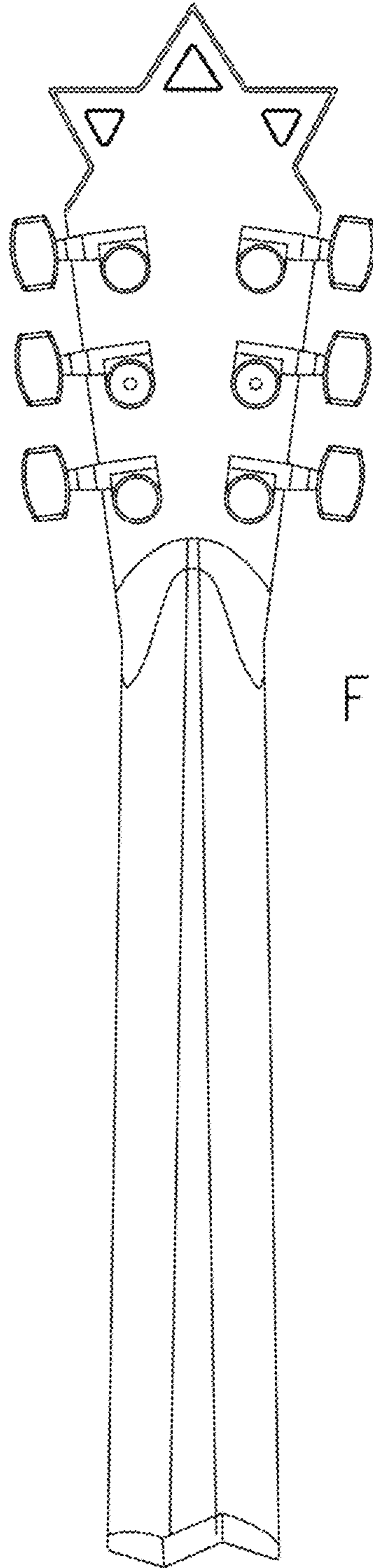
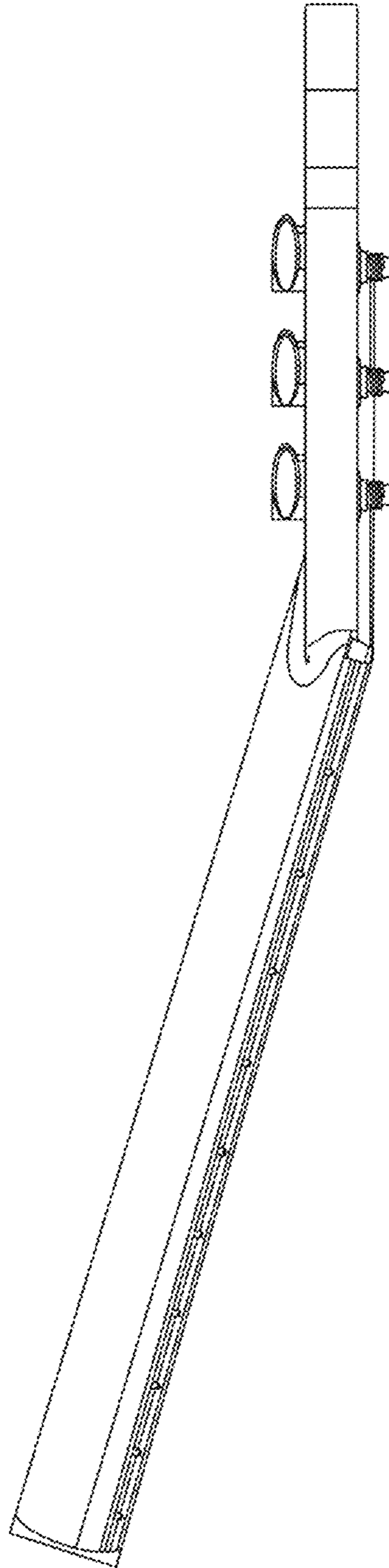

FIG. 4

FIG. 5



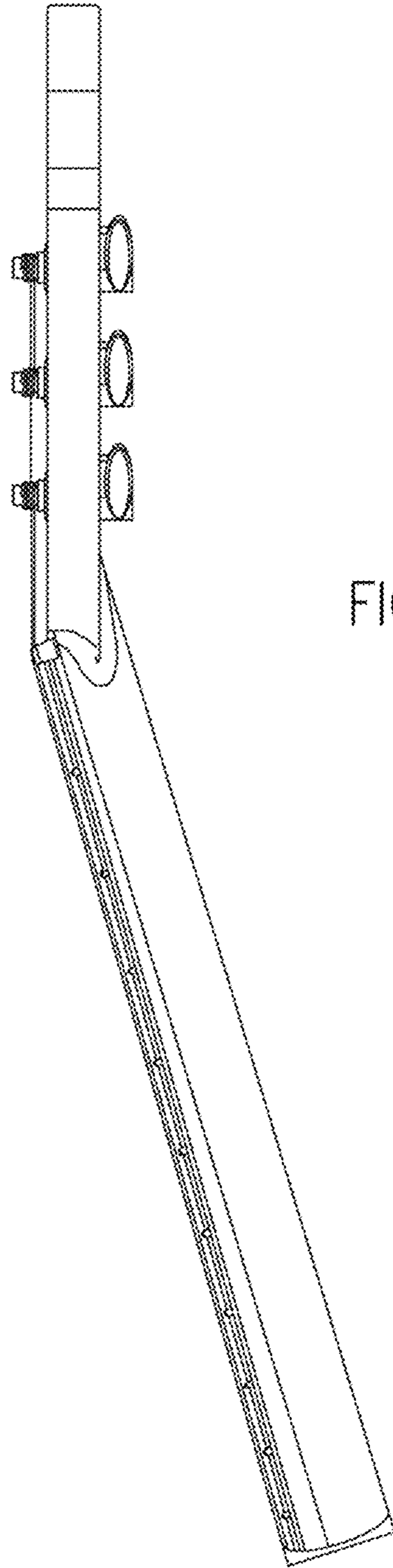

FIG. 6

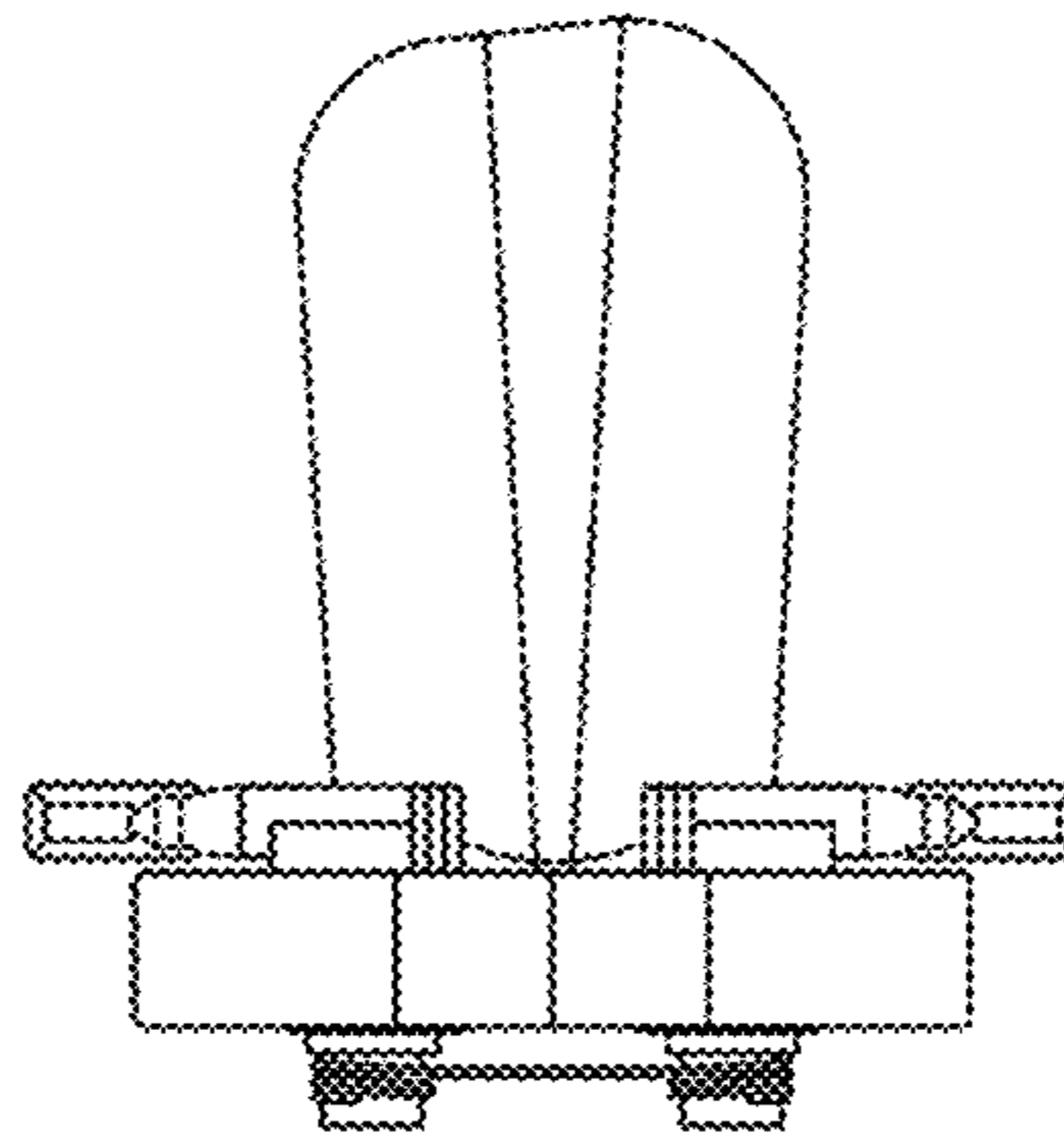

FIG. 7

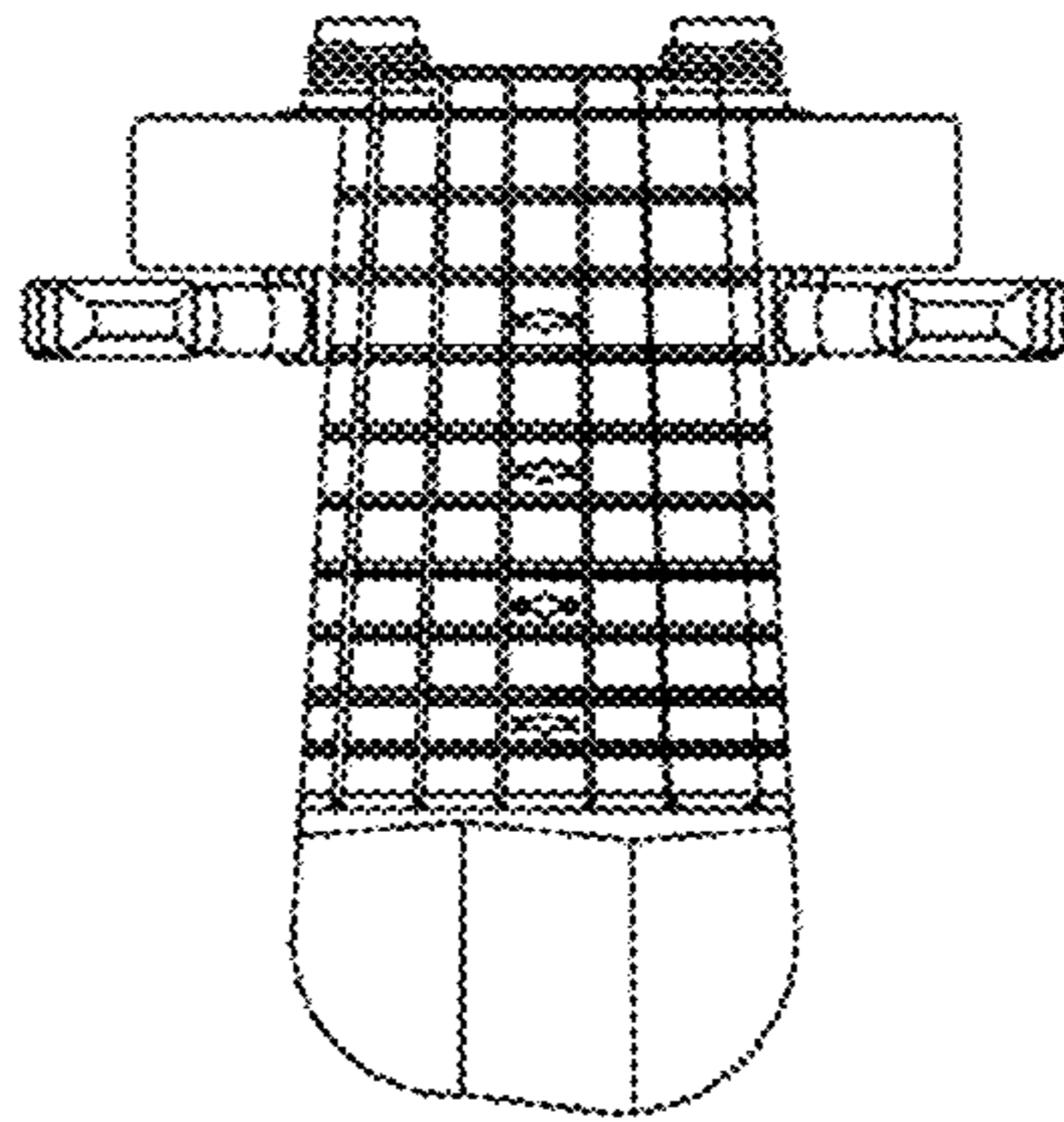

FIG. 8