

US00D772137S

(12) **United States Design Patent** (10) **Patent No.:** **US D772,137 S**
Ivans et al. (45) **Date of Patent:** **** *Nov. 22, 2016**

(54) **TILTROTOR AIRCRAFT LANDING GEAR**

(71) Applicant: **Bell Helicopter Textron Inc.**, Fort Worth, TX (US)

(72) Inventors: **Steven Ivans**, Ponder, TX (US); **Berlin Benfield**, Grapevine, TX (US); **Cory Hitte**, Fort Worth, TX (US)

(73) Assignee: **Bell Helicopter Textron Inc.**, Fort Worth, TX (US)

(*) Notice: This patent is subject to a terminal disclaimer.

(**) Term: **14 Years**

(21) Appl. No.: **29/470,691**

(22) Filed: **Oct. 24, 2013**

(51) **LOC (10) Cl.** **12-07**

(52) **U.S. Cl.**
USPC **D12/345**

(58) **Field of Classification Search**
USPC D12/16.1, 319-345; D21/441, 442, D21/447, 450, 453

CPC B64C 25/00; B64C 25/04; B64C 25/06; B64C 25/14; B64C 25/22; B64C 25/34; B64C 25/60; B64C 25/66; B64C 7/00; B64C 7/02; B64C 27/00; B64C 27/008; B64C 27/04; B64C 27/08; B64C 27/10; B64C 27/22; B64C 29/00; B64C 29/0033; B64C 29/02

See application file for complete search history.

(56) **References Cited**

U.S. PATENT DOCUMENTS

2,856,180 A * 10/1958 Westcott, Jr. 267/64.15
4,062,507 A * 12/1977 Felder 244/17.17

4,556,179 A * 12/1985 Veaux et al. 244/102 R
4,770,372 A * 9/1988 Ralph 244/102 R
4,995,574 A * 2/1991 Bernard et al. 244/17.17
5,029,775 A * 7/1991 Abramovitsh 244/102 R
5,337,976 A * 8/1994 Derrien 244/102 A
6,260,793 B1 * 7/2001 Balayn et al. 244/7 R
6,349,901 B1 * 2/2002 Grossman 244/102 R
6,360,991 B1 * 3/2002 Alan 244/103 W
6,607,161 B1 * 8/2003 Krysinski et al. 244/7 A
7,051,977 B2 * 5/2006 Yoshioka 244/103 R
7,188,802 B2 * 3/2007 Magre 244/7 R
7,575,193 B2 * 8/2009 Payen et al. 244/100 R
7,621,481 B2 * 11/2009 Hershberger et al. 244/102 A
D632,633 S * 2/2011 Masson D12/345
8,251,305 B2 * 8/2012 Smith et al. 244/7 C
D687,364 S * 8/2013 Mitchell et al. D12/326
2011/0147518 A1 * 6/2011 Nannoni et al. 244/102 A

* cited by examiner

Primary Examiner — Martie K Holtje

(74) *Attorney, Agent, or Firm* — Bell Helicopter Textron Inc

(57) **CLAIM**

The ornamental design for a tiltrotor aircraft landing gear, as shown and described.

DESCRIPTION

FIG. 1 is a front perspective view of the tiltrotor aircraft landing gear showing our new design; FIG. 2 is a front elevational view thereof; FIG. 3 is a rear elevational view thereof; FIG. 4 is a right side elevational view thereof; FIG. 5 is a left side elevational view thereof; FIG. 6 is a top plan view thereof; and, FIG. 7 is a bottom plan view thereof.

The tiltrotor aircraft depicted by broken lines in the drawings has been shown for the purpose of illustrating environment that forms no part of the claimed design.

1 Claim, 5 Drawing Sheets

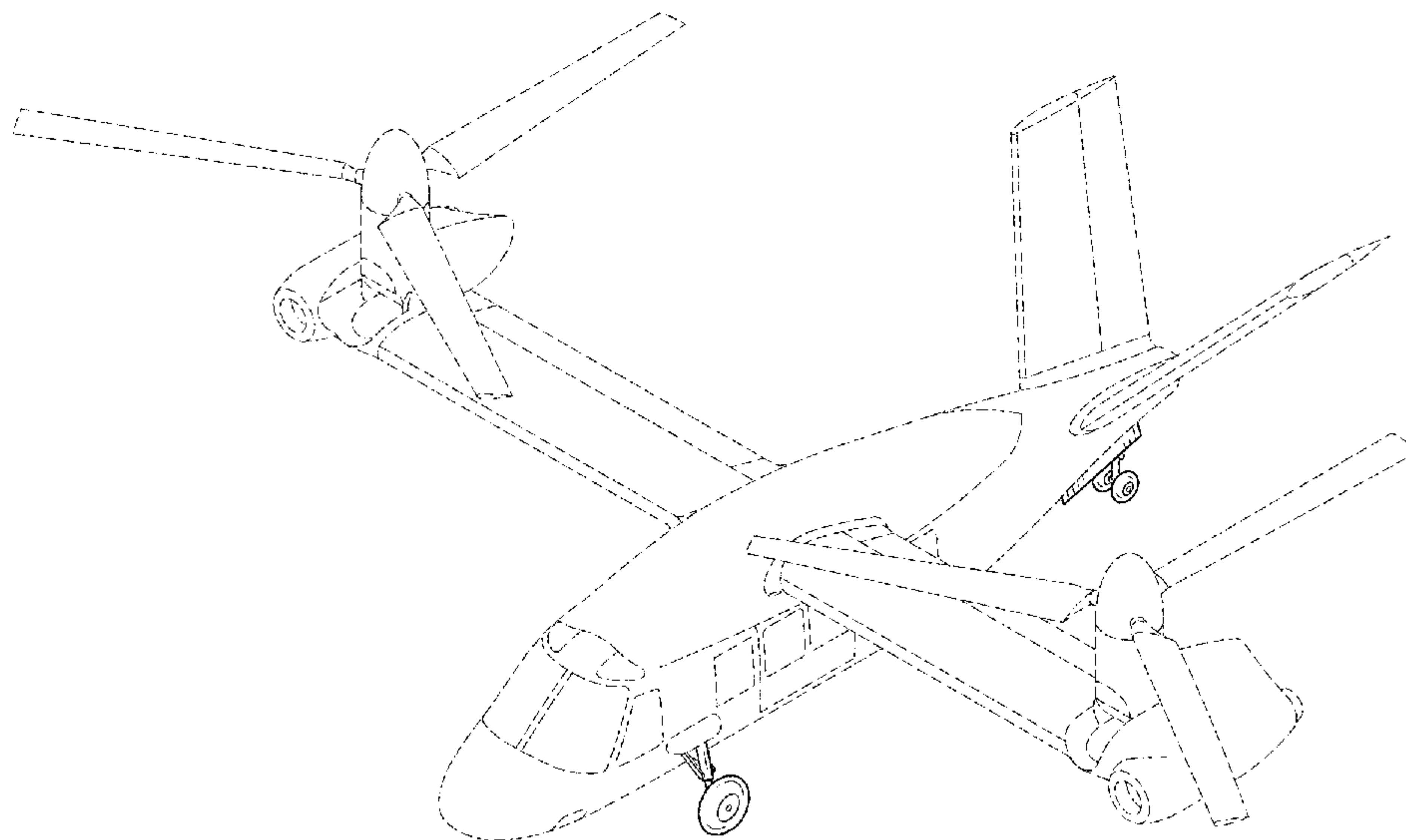

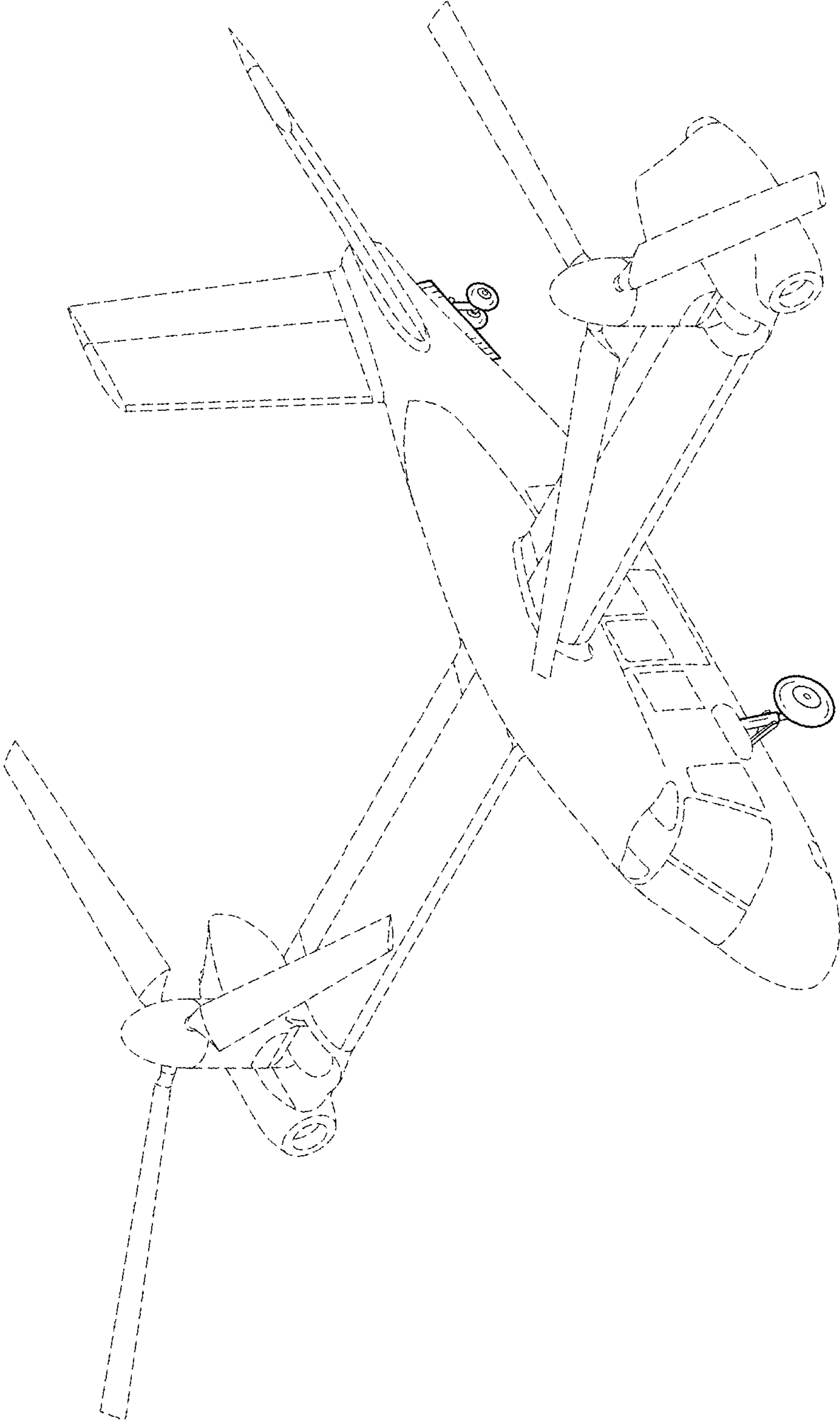

FIG. 1

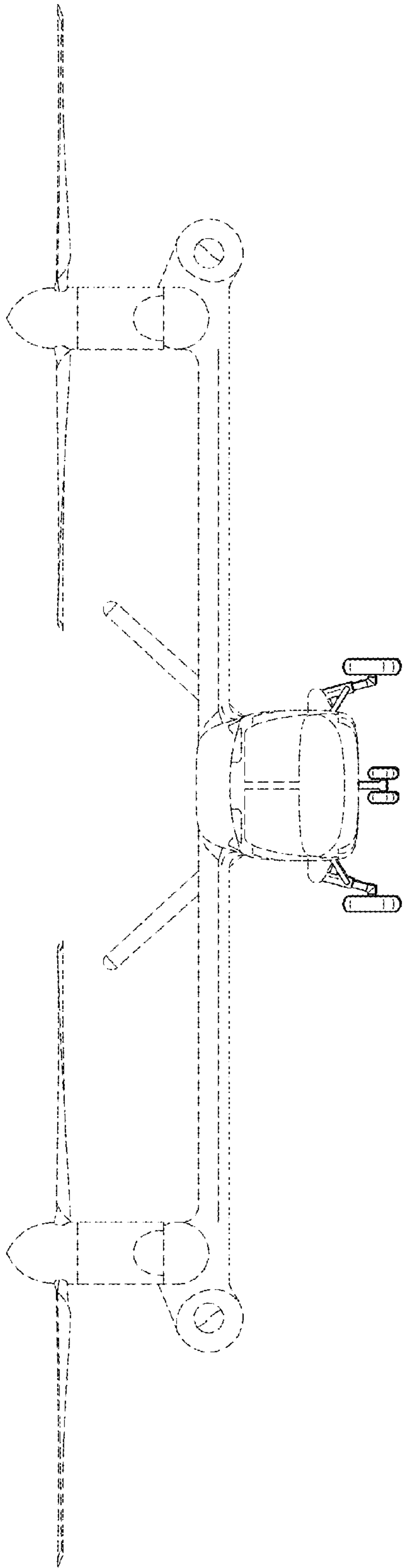

FIG. 2

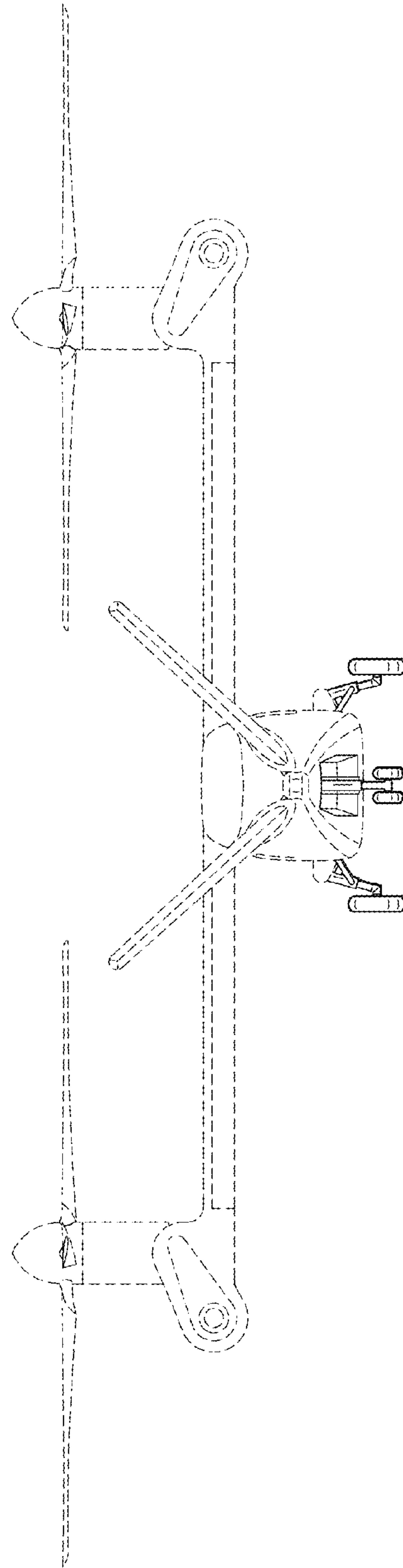

FIG. 3

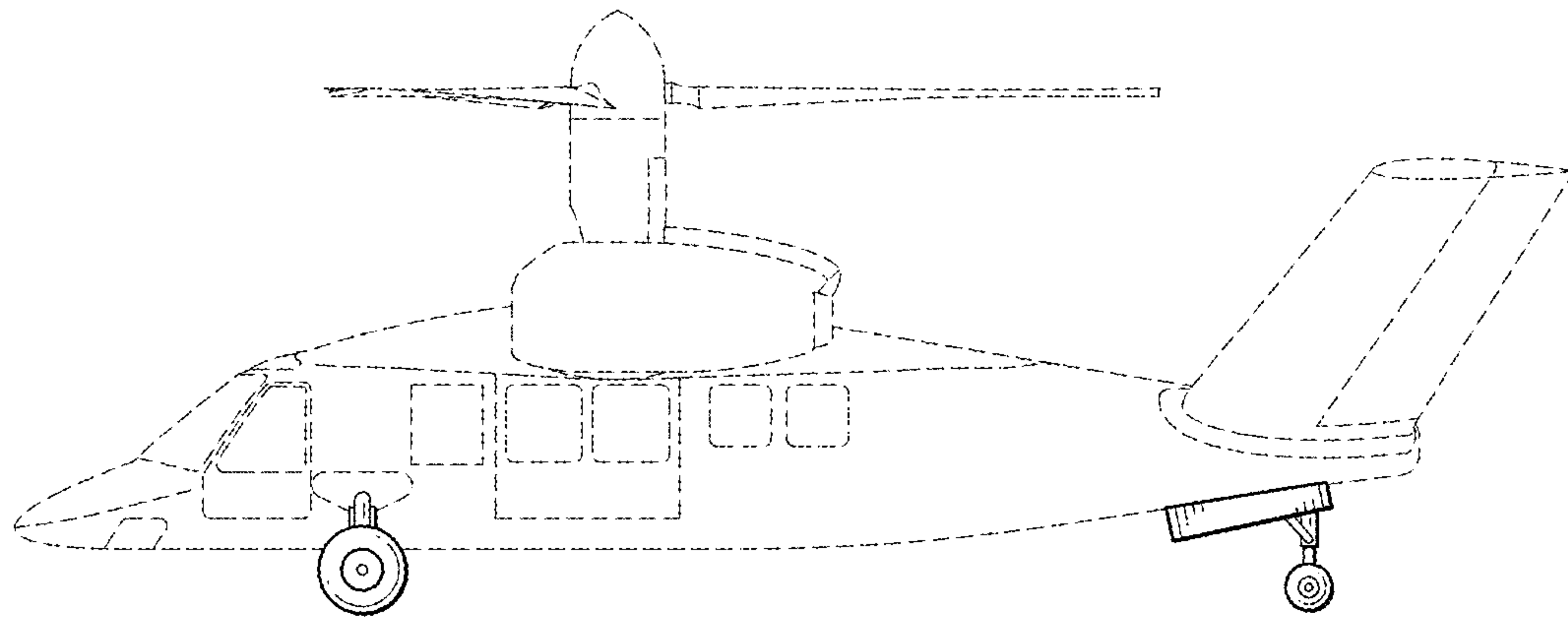

FIG. 4

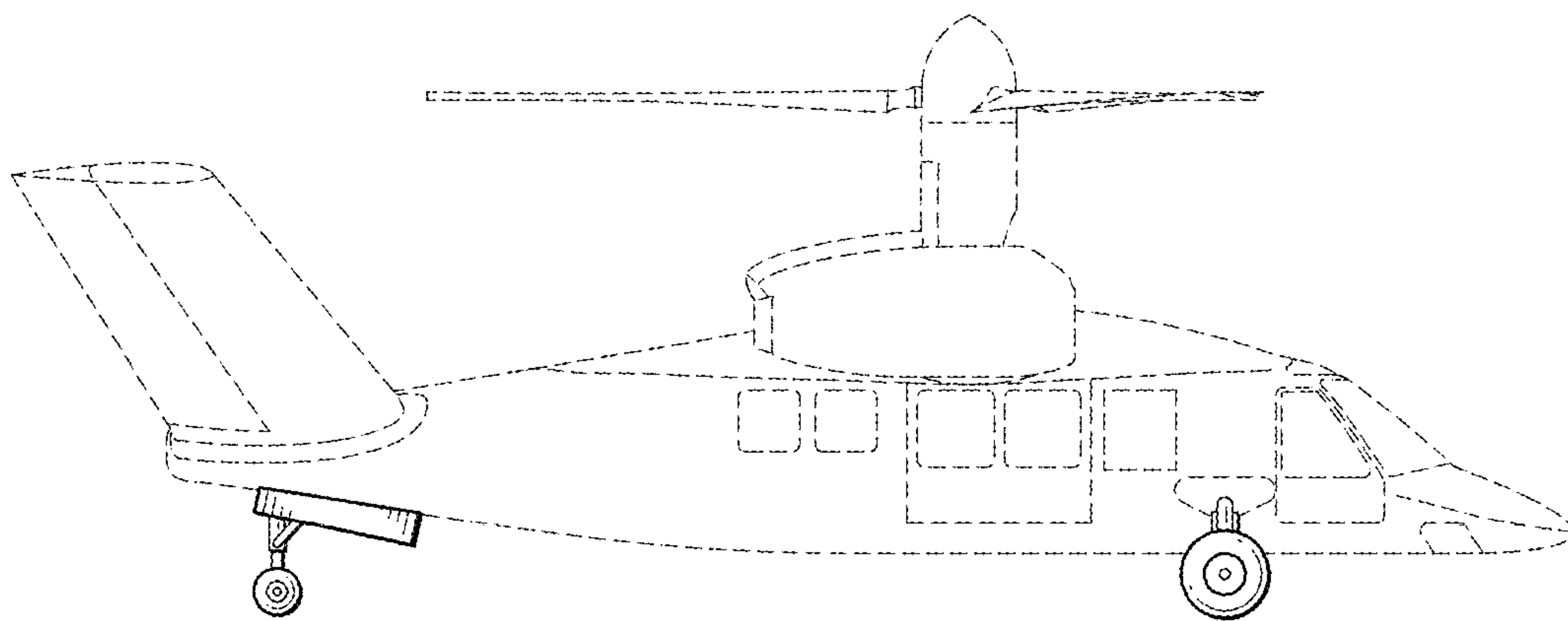

FIG. 5

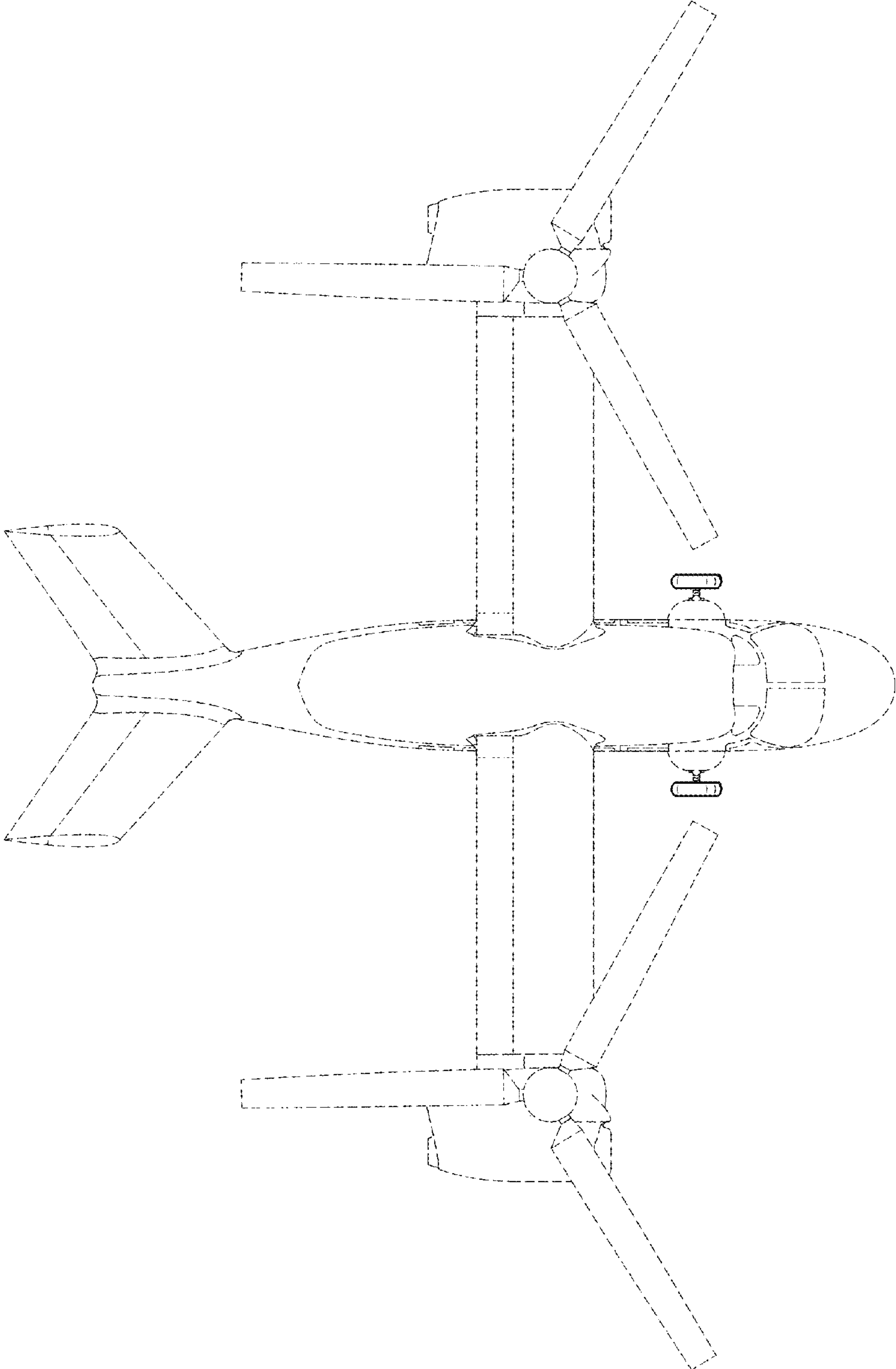

FIG. 6

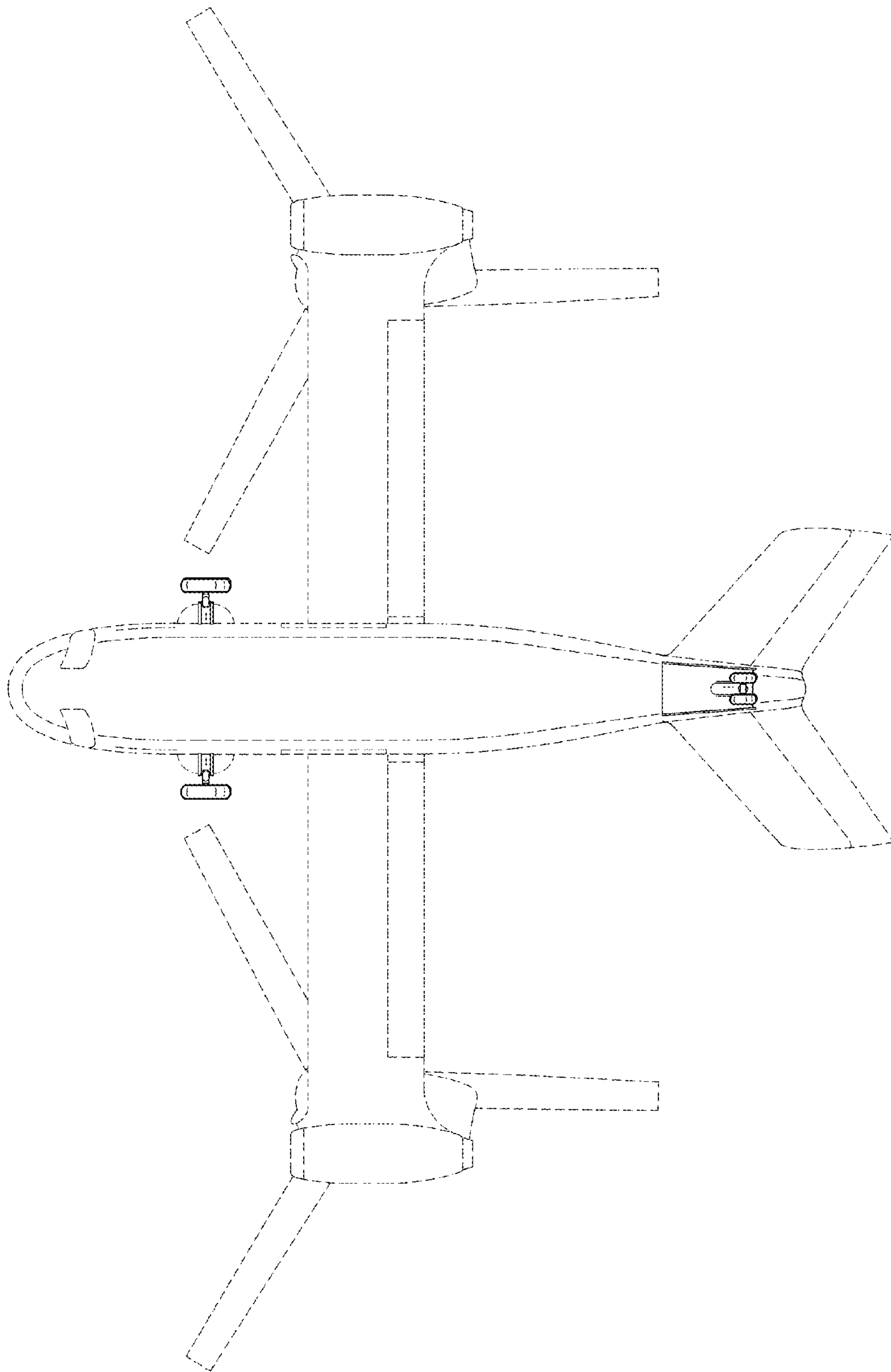

FIG. 7