



US00D771949S

(12) **United States Design Patent** (10) **Patent No.:** **US D771,949 S**
Lin (45) **Date of Patent:** **** Nov. 22, 2016**

(54) **GOLF CLUB SHAFT PROTECTOR**

(71) Applicant: **Zhuhai Shichang Metals Ltd., Zhuhai (CN)**

(72) Inventor: **Wen-Sheng Lin, Kaohsiung (TW)**

(73) Assignee: **Zhuhai Shichang Metals Ltd. (CN)**

(**) Term: **14 Years**

(21) Appl. No.: **29/510,256**

(22) Filed: **Nov. 26, 2014**

(51) **LOC (10) Cl.** **21-02**

(52) **U.S. Cl.**
USPC **D3/320**

(58) **Field of Classification Search**
USPC D21/789, 796; D3/201, 221, 254, 255,
D3/315, 318-320
CPC A63B 55/00
See application file for complete search history.

(56) **References Cited**

U.S. PATENT DOCUMENTS

- 2,595,987 A * 5/1952 Shears A63B 55/00
206/315.6
- 3,985,229 A * 10/1976 Maki A63B 55/10
206/315.6
- 4,194,547 A * 3/1980 Sidor A63B 55/00
206/315.6
- 4,497,404 A 2/1985 Lowrance
- 4,664,382 A * 5/1987 Palmer A63B 53/00
206/315.6
- 4,746,014 A 5/1988 Very
- 4,932,523 A * 6/1990 Yamazoe A63B 55/00
206/315.2
- 4,938,349 A * 7/1990 Burns A63B 55/00
206/315.6
- D318,705 S * 7/1991 Arato D21/754
- 5,050,884 A 9/1991 Flory
- 5,088,600 A * 2/1992 Kopp, Jr. A63B 55/00
150/160
- 5,275,278 A * 1/1994 Henry A63B 55/00
150/160
- D348,092 S 6/1994 Misko, Jr.

- D351,444 S * 10/1994 Hunter D21/796
- 5,392,907 A * 2/1995 Blanchard A63B 55/00
206/315.3
- D359,785 S * 6/1995 Kent D21/796
- 5,573,241 A 11/1996 Anderson
- 5,632,690 A * 5/1997 McConville A63B 55/00
206/315.6
- 5,720,388 A * 2/1998 King A63B 57/00
150/160
- 6,216,864 B1 * 4/2001 Chang A63B 55/00
206/315.2
- 6,343,692 B1 * 2/2002 Park A63B 55/00
206/315.2
- 6,619,475 B2 * 9/2003 Chang A63B 55/00
206/315.3
- 6,929,124 B2 8/2005 Kawasaki
- D550,456 S * 9/2007 Keen D21/796
- 7,284,659 B2 * 10/2007 Sugarek A63B 55/10
206/315.2
- 7,886,787 B1 2/2011 Wilson

FOREIGN PATENT DOCUMENTS

WO 0102064 A1 1/2001

* cited by examiner

Primary Examiner — Mitchell Siegel

(74) *Attorney, Agent, or Firm* — Luedeka Neely Group, P.C.

(57) **CLAIM**

The ornamental design of a golf club shaft protector, as shown and described.

DESCRIPTION

FIG. 1 is a top perspective view of the golf club shaft protector;
FIG. 2 is a bottom perspective view of the golf club shaft protector;
FIG. 3 is a side view of the golf club shaft protector;
FIG. 4 is a top plan view of the golf club shaft protector;
FIG. 5 is a bottom plan view of the golf club shaft protector;
and,
FIG. 6 is a top perspective view of the golf club shaft protector.
The broken away section is shown for ease of illustration.

1 Claim, 3 Drawing Sheets

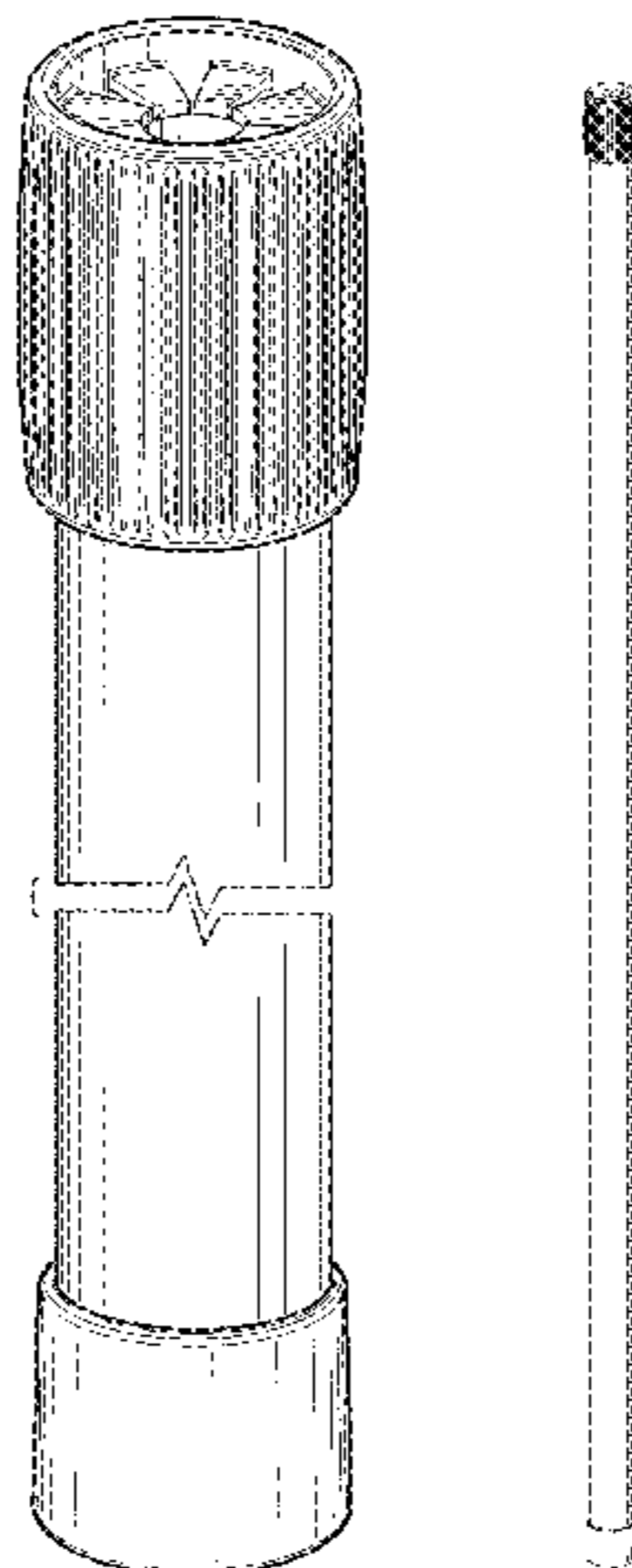

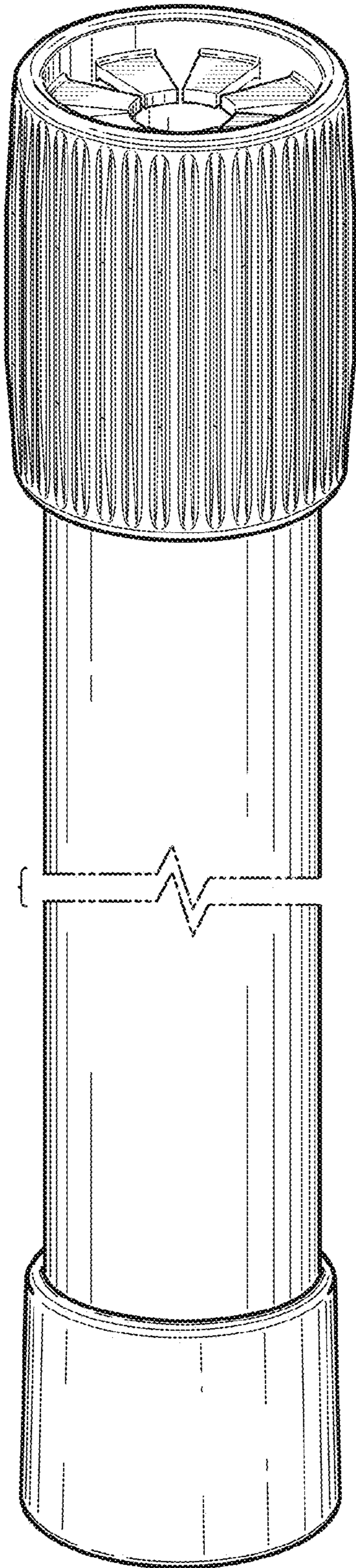

FIG. 1

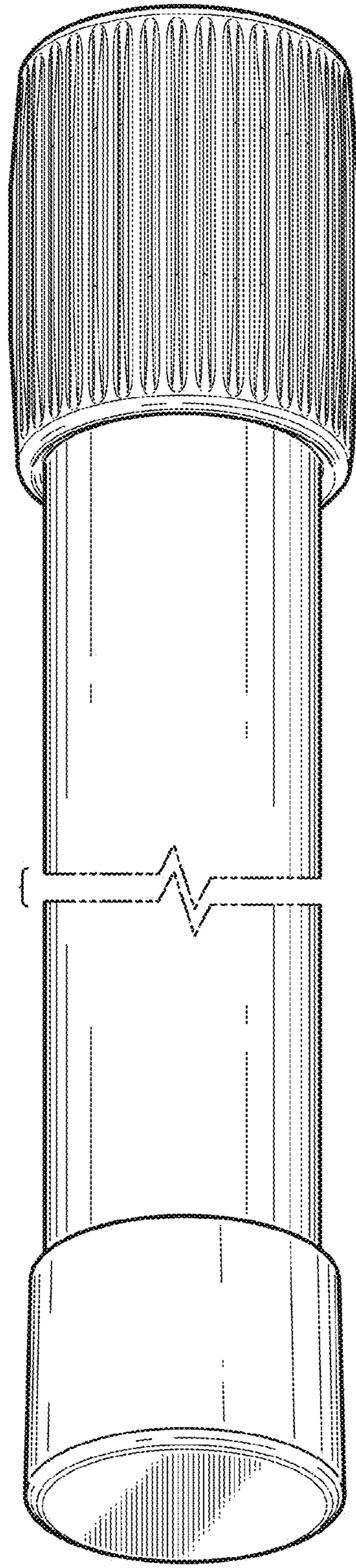

FIG. 2

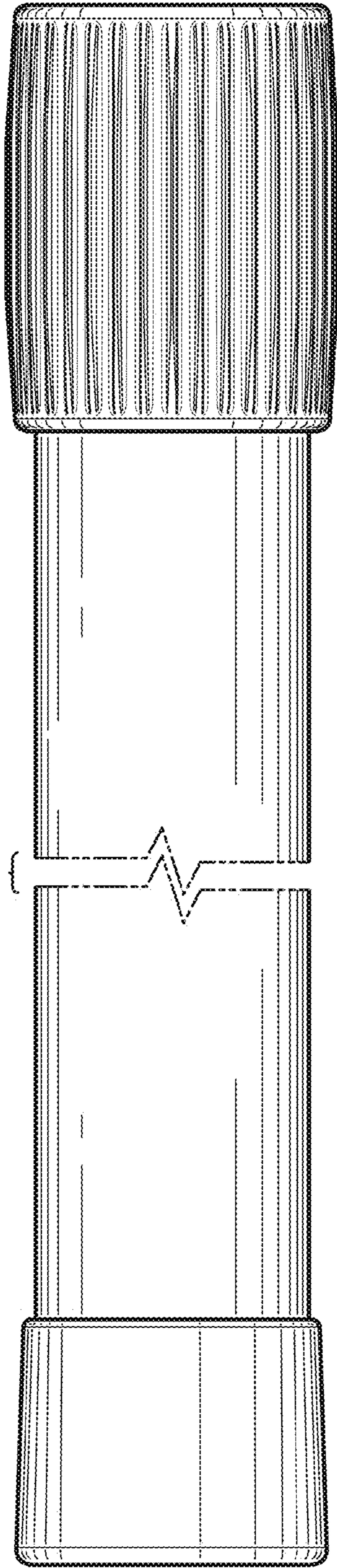

FIG. 3

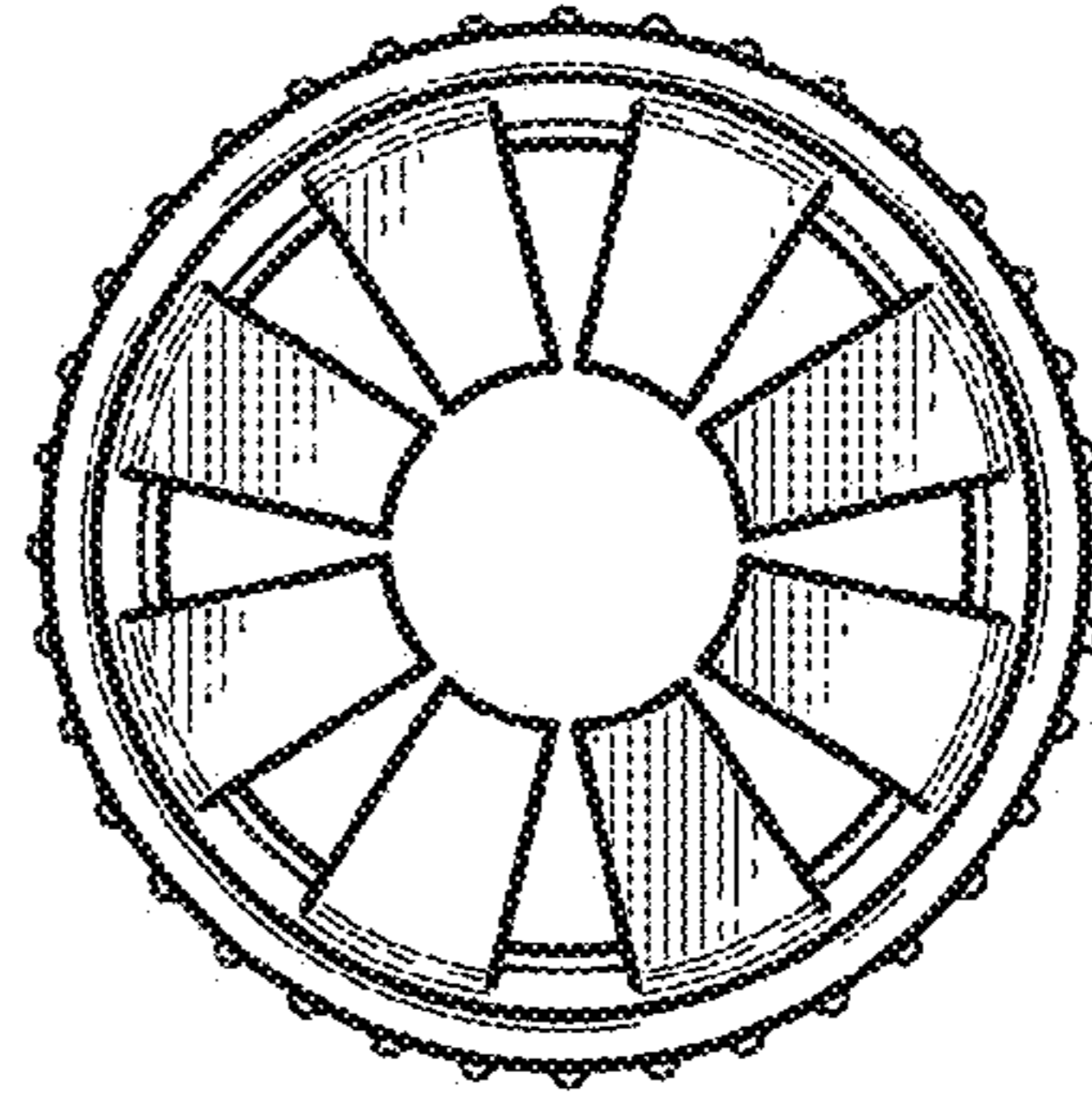

FIG. 4

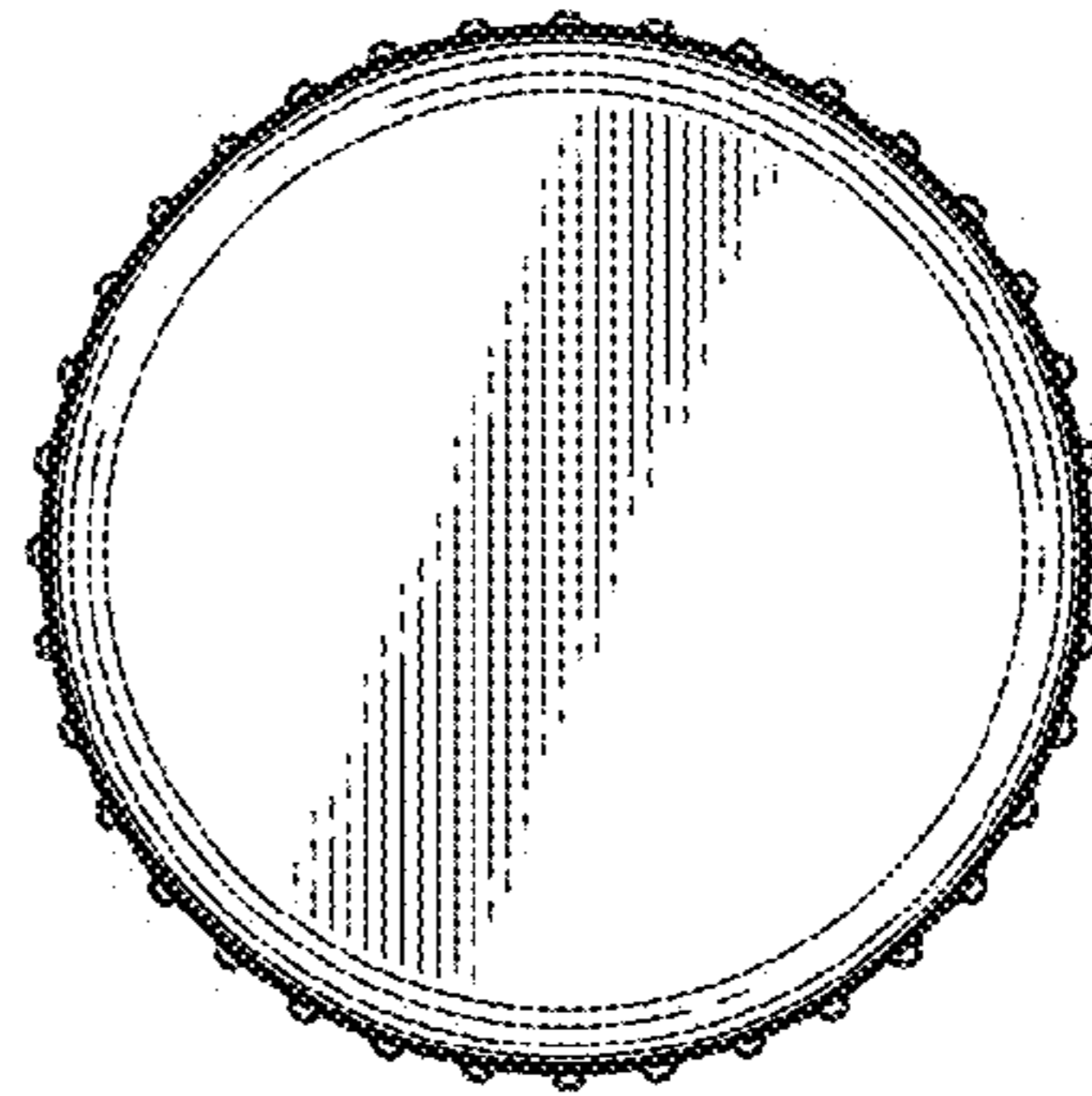

FIG. 5

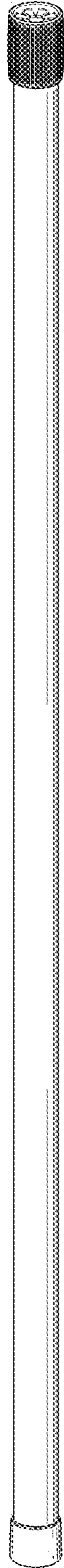

FIG. 6