



US00D771788S

(12) **United States Design Patent**
Duckwitz

(10) **Patent No.:** **US D771,788 S**

(45) **Date of Patent:** **** Nov. 15, 2016**

(54) **INSULATED HOUSING FOR COILED HEAT EXCHANGER TUBE**

(71) Applicant: **Turbotec Products, Inc.**, Newton, NC (US)

(72) Inventor: **Todd A. Duckwitz**, Hickory, NC (US)

(73) Assignee: **Turbotec Products, Inc.**, Newton, NC (US)

(**) Term: **14 Years**

(21) Appl. No.: **29/479,773**

(22) Filed: **Jan. 20, 2014**

(51) **LOC (10) Cl.** **23-03**

(52) **U.S. Cl.**
USPC **D23/386**

(58) **Field of Classification Search**
USPC D23/386, 355, 356, 359, 360, 362, 352, D23/366, 369, 332, 333, 335, 336, 342, D23/259-266, 324, 364; 422/120, 122; 55/473, 504; 210/497.1, 136, 321.83; 96/97; 251/366; 206/319; 285/133.11; 165/157, 51, 52, 159, 160, 163; 138/38; 123/557

CPC F28F 13/18; F28F 2270/00; B23P 15/26; Y10T 29/4935; F28D 2021/0068; F25B 2339/047

See application file for complete search history.

(56) **References Cited**

U.S. PATENT DOCUMENTS

- 3,936,078 A * 2/1976 Wallyn F16L 55/0337 285/294.1
- 4,691,998 A * 9/1987 Sakagaito G02B 26/121 359/216.1
- 4,727,410 A * 2/1988 Higgins, III H01L 23/13 174/538

- 4,922,059 A * 5/1990 Walker H05K 3/0014 174/254
- 5,419,042 A * 5/1995 Kado B23P 11/00 29/515
- 5,458,433 A * 10/1995 Stastny B27F 5/02 144/136.95
- 5,685,224 A * 11/1997 Dean B05C 17/035 101/328
- D520,621 S * 5/2006 Moser, III D23/365
- D648,005 S * 11/2011 Morishita D23/259
- D737,410 S * 8/2015 Wyne D23/259
- 2011/0275022 A1* 11/2011 Griffith F16L 19/025 431/121
- 2013/0075645 A1* 3/2013 Hung F16L 41/021 251/366
- 2015/0204624 A1* 7/2015 Duckwitz B23P 15/26 165/135

* cited by examiner

Primary Examiner — David Muller

Assistant Examiner — Nathan Johnston

(74) *Attorney, Agent, or Firm* — Alix, Yale & Ristas, LLP

(57) **CLAIM**

The ornamental design for an insulated housing for coiled heat exchanger tube, as shown and described.

DESCRIPTION

FIG. 1 is a perspective view of an insulated housing for coiled heat exchanger tube showing my new design; FIG. 2 is a front elevation view thereof; FIG. 3 is a right side elevation view thereof; FIG. 4 is a left side elevation view thereof; and, FIG. 5 is a top plan view thereof.

The features shown in broken lines depict environmental subject matter only and form no part of the claimed design. The insulated housing for the coiled heat exchanger is shown with a symbolic break in its length. The appearance of any portion of the article between the break lines forms no part of the claimed design.

1 Claim, 2 Drawing Sheets

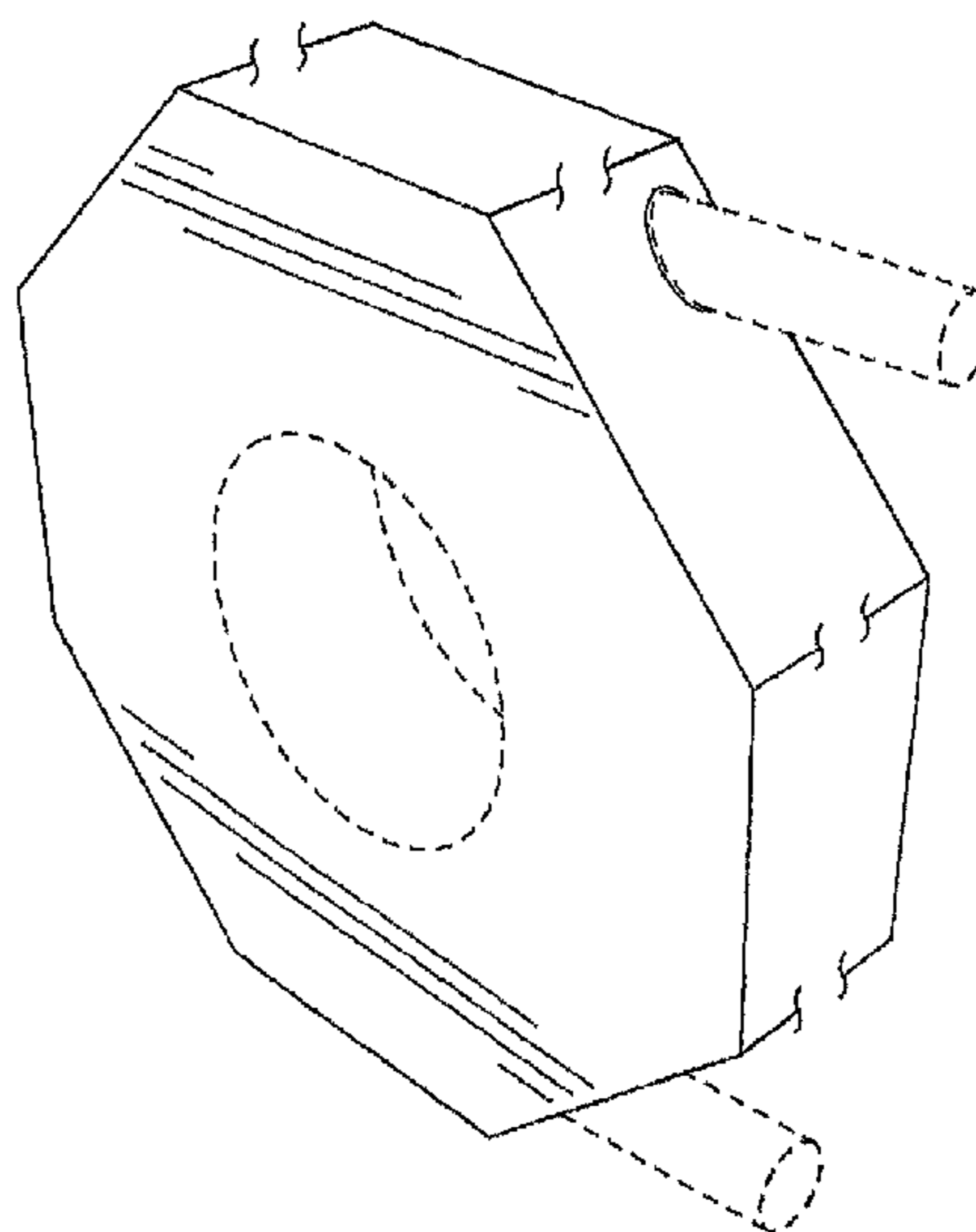

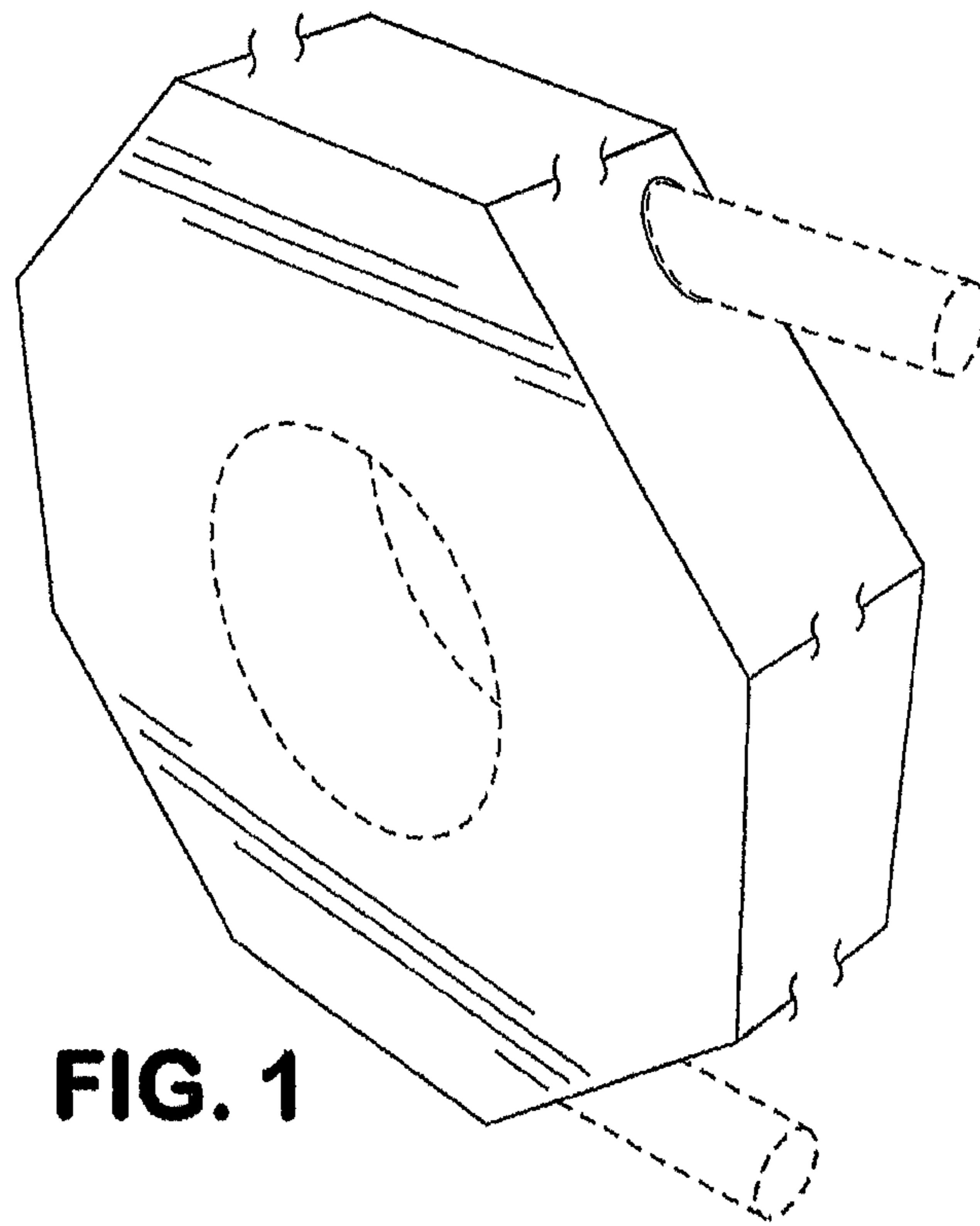

FIG. 1

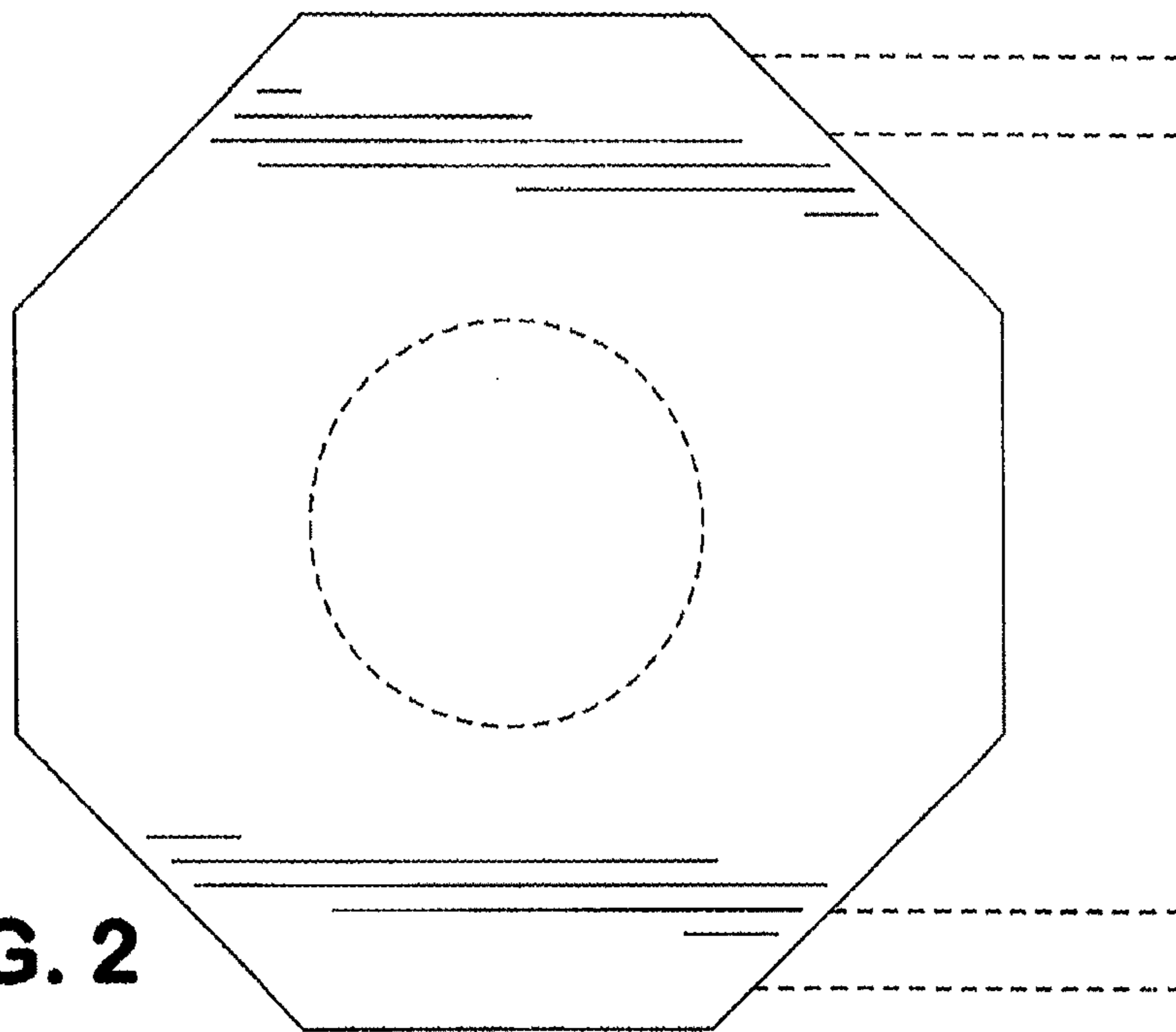

FIG. 2

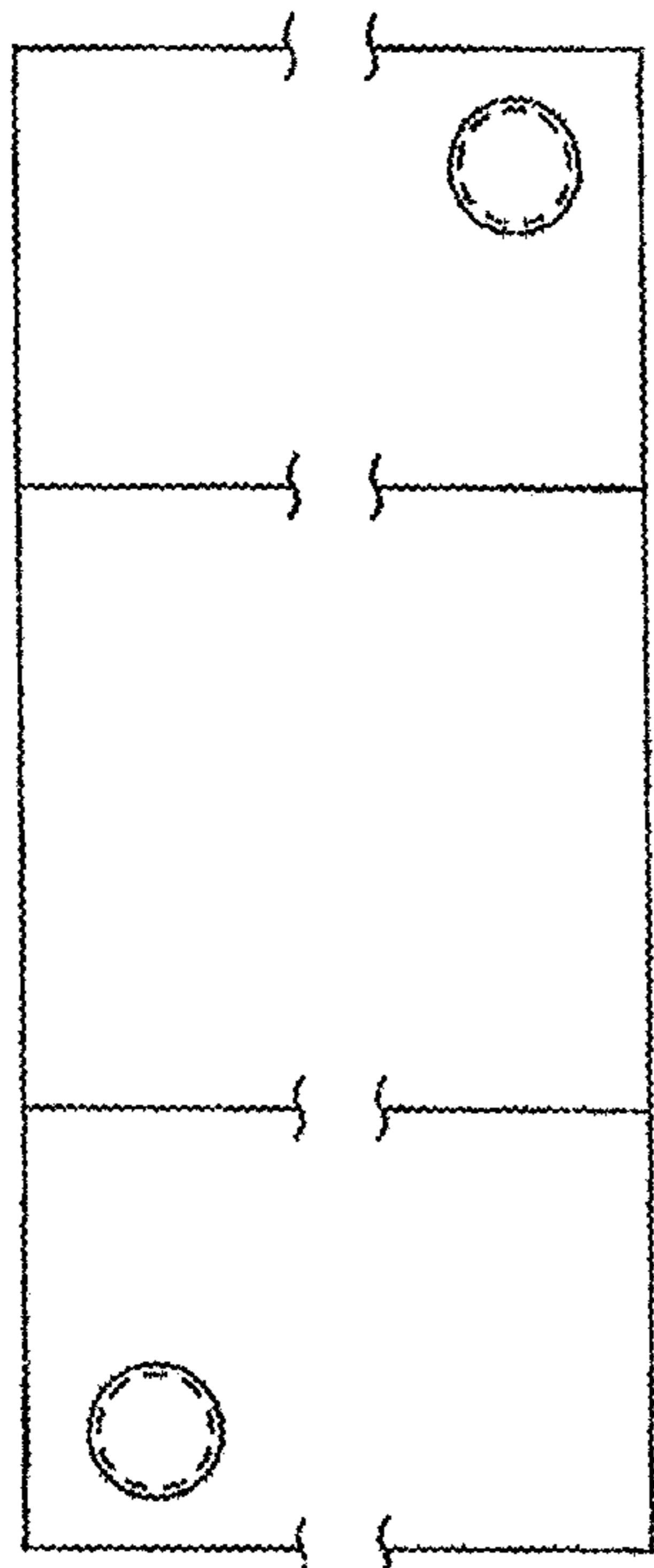

FIG. 3

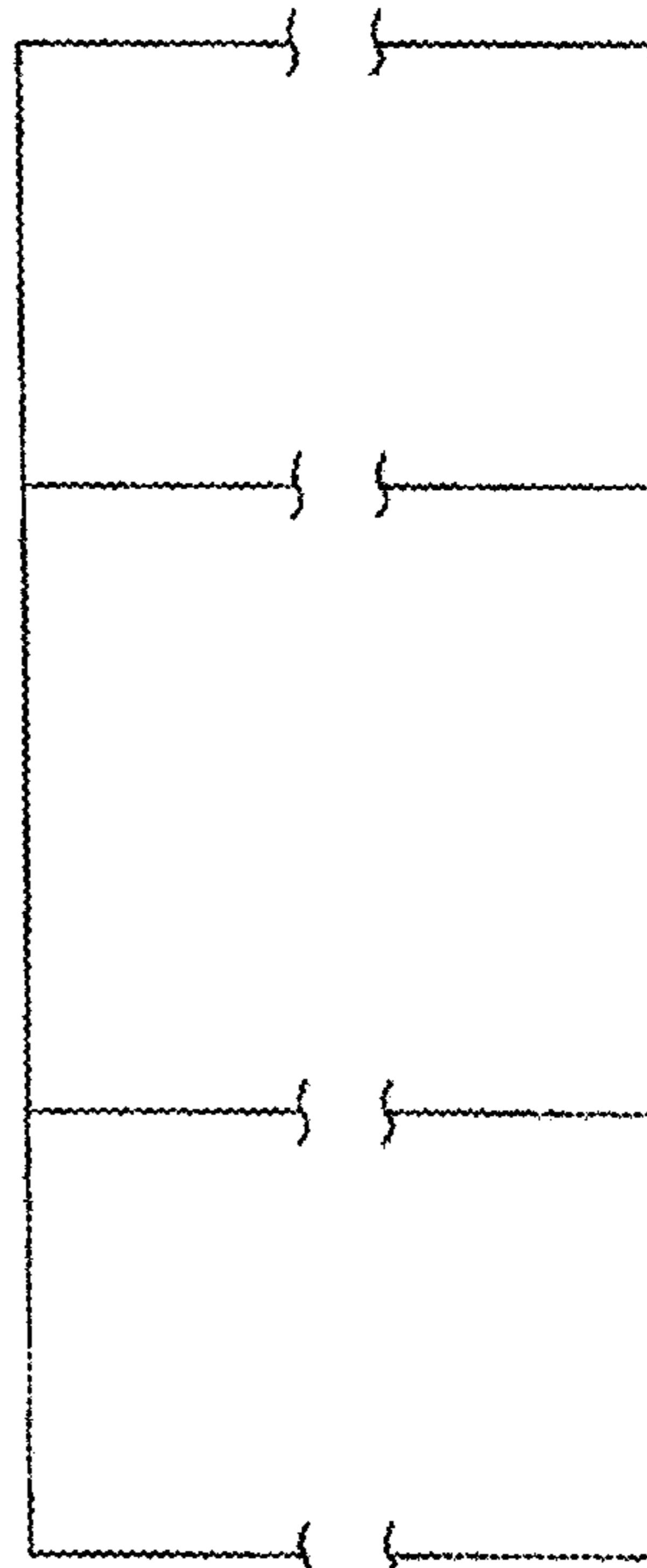

FIG. 4

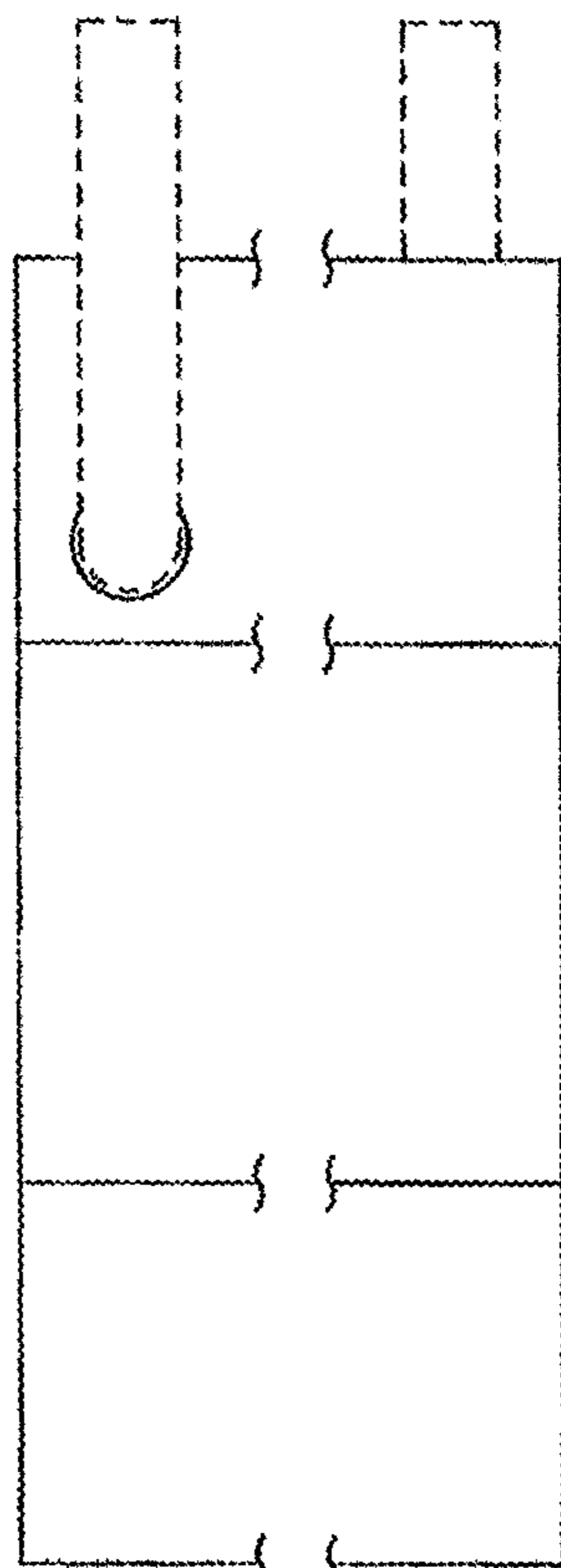

FIG. 5