



US00D771570S

(12) **United States Design Patent** (10) **Patent No.:** **US D771,570 S**
Ngo (45) **Date of Patent:** **** Nov. 15, 2016**

(54) **ELECTRICALLY CONDUCTIVE CONTACT**

(71) Applicant: **Hung Viet Ngo**, Austin, TX (US)

(72) Inventor: **Hung Viet Ngo**, Austin, TX (US)

(73) Assignee: **FCI Americas Technology LLC**,
Carson City, NV (US)

(**) Term: **15 Years**

(21) Appl. No.: **29/527,375**

(22) Filed: **May 19, 2015**

(51) **LOC (10) Cl.** **13-03**

(52) **U.S. Cl.**
USPC **D13/154**

(58) **Field of Classification Search**
USPC D13/120, 133, 147, 154, 184, 199
CPC H01R 4/18; H01R 4/185; H01R 11/22;
H01R 13/11; H01R 13/112; H01R 13/113;
H01R 13/53; H01R 13/64; H01R 13/645;
H01R 13/6456

See application file for complete search history.

(56) **References Cited**

U.S. PATENT DOCUMENTS

5,997,347	A *	12/1999	Robinson	H01R 13/426 439/517
6,280,216	B1	8/2001	Bernier et al.		
6,776,635	B2 *	8/2004	Blanchfield	H01R 9/091 439/181
D569,343	S *	5/2008	Hung	D13/133
D617,741	S *	6/2010	Fennell	D13/154
D722,570	S *	2/2015	Choi	D13/154
9,130,287	B2 *	9/2015	Tai	H01R 13/112
D742,838	S *	11/2015	Yang	D13/154

* cited by examiner

Primary Examiner — Daniel Bui

(74) *Attorney, Agent, or Firm* — Wolf, Greenfield & Sacks, P.C.

(57) **CLAIM**

The ornamental design for an electrically conductive contact, as shown and described.

DESCRIPTION

FIG. 1 is a top, left, front perspective view of an electrically conductive contact according to one embodiment of my design;

FIG. 2 is a top, left, rear perspective view thereof;

FIG. 3 is a top, right, front perspective view thereof;

FIG. 4 is a top, right, rear perspective view thereof;

FIG. 5 is a bottom, left, front perspective view thereof;

FIG. 6 is a bottom, left, rear perspective view thereof;

FIG. 7 is a front elevation view thereof;

FIG. 8 is a rear elevation view thereof;

FIG. 9 is a right side elevation view thereof;

FIG. 10 is a left side elevation view thereof;

FIG. 11 is a top plan view thereof;

FIG. 12 is a bottom plan view thereof;

FIG. 13 is an enlarged view of Region 13 of FIG. 2, as viewed from the top and right side of FIG. 2;

FIG. 14 is an enlarged view of Region 14 of FIG. 5, as viewed from the bottom and right side of FIG. 5;

FIG. 15 is a top, left, front perspective view of an electrically conductive contact according to another embodiment of my design;

FIG. 16 is a top, left, rear perspective view thereof;

FIG. 17 is a top, right, front perspective view thereof;

FIG. 18 is a top, right, rear perspective view thereof;

FIG. 19 is a bottom, left, front perspective view thereof;

FIG. 20 is a bottom, left, rear perspective view thereof;

FIG. 21 is a front elevation view thereof;

FIG. 22 is a rear elevation view thereof;

FIG. 23 is a right side elevation view thereof;

FIG. 24 is a left side elevation view thereof;

FIG. 25 is a top plan view thereof;

FIG. 26 is a bottom plan view thereof;

FIG. 27 is an enlarged view of Region 27 of FIG. 16, as viewed from the top and right side of FIG. 16;

FIG. 28 is an enlarged view of Region 28 of FIG. 19, as viewed from the bottom and right side of FIG. 19;

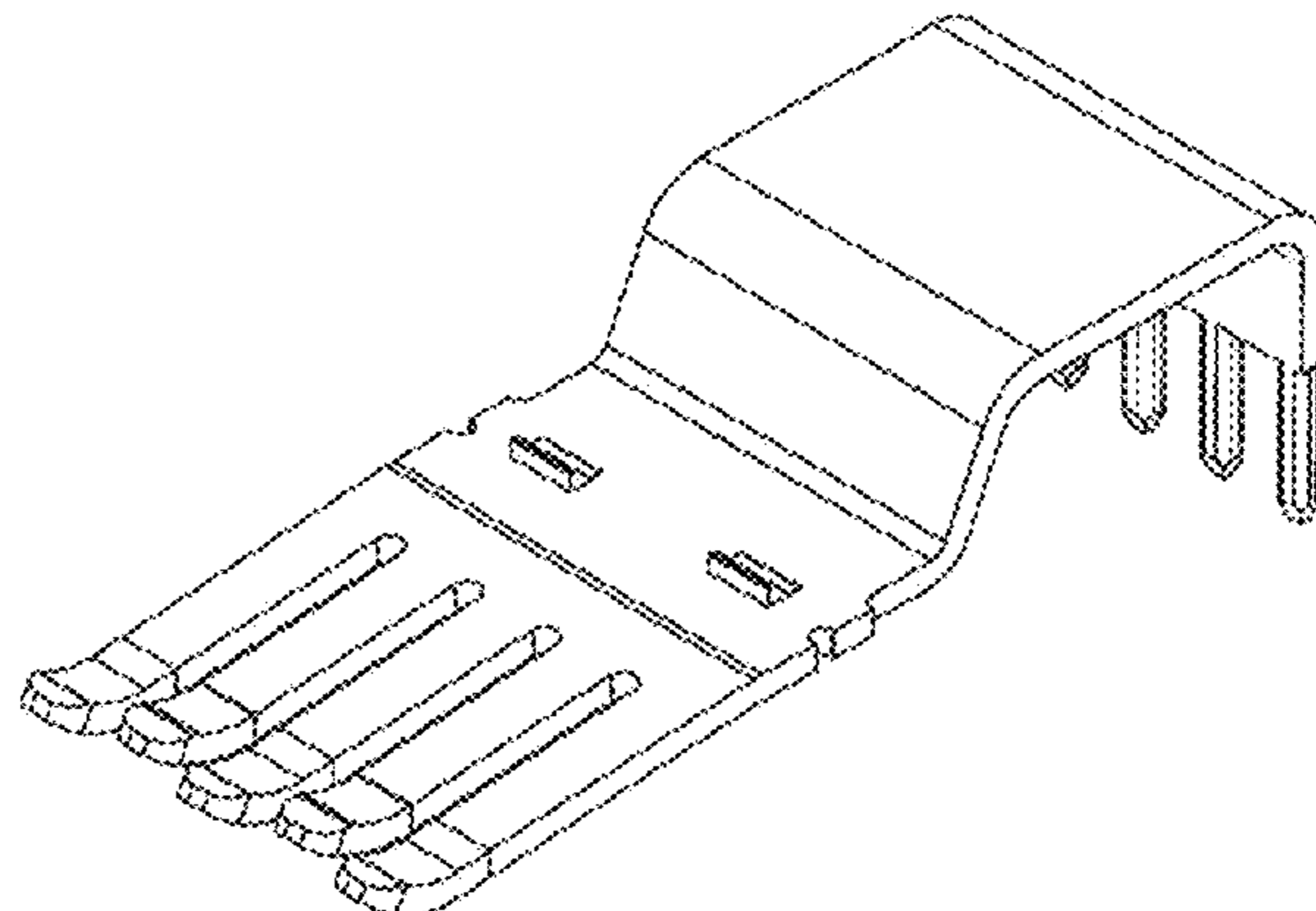
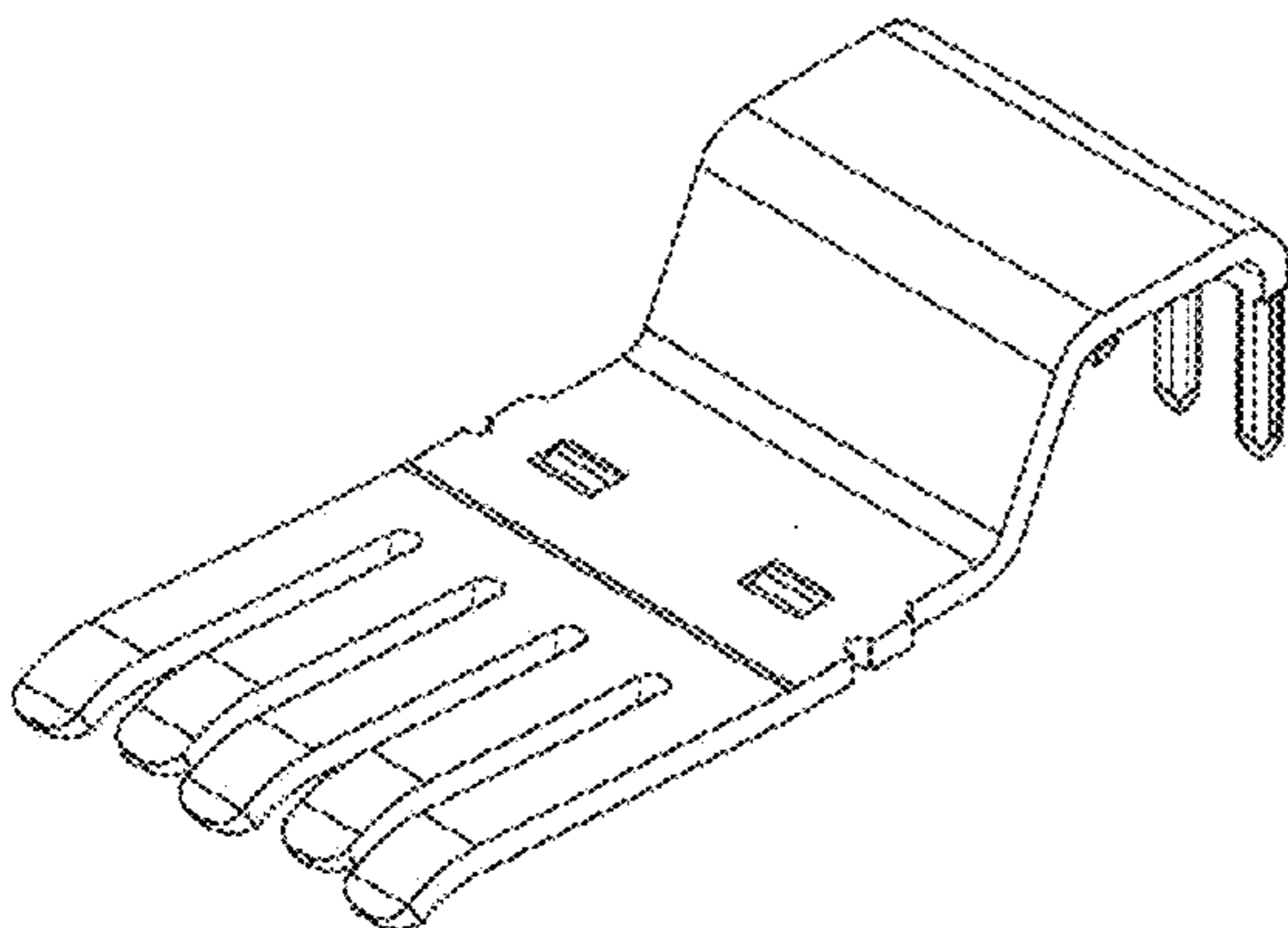

FIG. 29 is a top, left, front perspective view of an electrically conductive contact according to another embodiment of my design;

FIG. 30 is a top, left, rear perspective view thereof;

FIG. 31 is a top, right, front perspective view thereof;

FIG. 32 is a top, right, rear perspective view thereof;

FIG. 33 is a bottom, left, front perspective view thereof;

FIG. 34 is a bottom, left, rear perspective view thereof;

FIG. 35 is a front elevation view thereof;

FIG. 36 is a rear elevation view thereof;

FIG. 37 is a right side elevation view thereof;

FIG. 38 is a left side elevation view thereof;

FIG. 39 is a top plan view thereof;

FIG. 40 is a bottom plan view thereof;

FIG. 41 is an enlarged view of Region 41 of FIG. 30, as viewed from the top and right side of FIG. 30;

FIG. 42 is an enlarged view of Region 42 of FIG. 33, as viewed from the bottom and right side of FIG. 33;

FIG. 43 is a top, left, front perspective view of an electrically conductive contact according to another embodiment of my design;

FIG. 44 is a top, left, rear perspective view thereof;

FIG. 45 is a top, right, front perspective view thereof;

FIG. 46 is a top, right, rear perspective view thereof;

FIG. 47 is a bottom, left, front perspective view thereof;

FIG. 48 is a bottom, left, rear perspective view thereof;

FIG. 49 is a front elevation view thereof;

FIG. 50 is a rear elevation view thereof;

FIG. 51 is a right side elevation view thereof;

FIG. 52 is a left side elevation view thereof;

FIG. 53 is a top plan view thereof;

FIG. 54 is a bottom plan view thereof;

FIG. 55 is an enlarged view of Region 55 of FIG. 44, as viewed from the top and right side of FIG. 44;

FIG. 56 is an enlarged view of Region 56 of FIG. 47, as viewed from the bottom and right side of FIG. 47;

FIG. 57 is a top, left, front perspective view of an electrically conductive contact according to another embodiment of my design;

FIG. 58 is a top, left, rear perspective view thereof;

FIG. 59 is a top, right, front perspective view thereof;

FIG. 60 is a top, right, rear perspective view thereof;

FIG. 61 is a bottom, left, front perspective view thereof;

FIG. 62 is a bottom, left, rear perspective view thereof;

FIG. 63 is a front elevation view thereof;

FIG. 64 is a rear elevation view thereof;

FIG. 65 is a right side elevation view thereof;

FIG. 66 is a left side elevation view thereof;

FIG. 67 is a top plan view thereof;

FIG. 68 is a bottom plan view thereof;

FIG. 69 is an enlarged view of Region 69 of FIG. 58, as viewed from the top and right side of FIG. 58;

FIG. 70 is an enlarged view of Region 70 of FIG. 61, as viewed from the bottom and right side of FIG. 61;

FIG. 71 is a top, left, front perspective view of an electrically conductive contact according to another embodiment of my design;

FIG. 72 is a top, left, rear perspective view thereof;

FIG. 73 is a top, right, front perspective view thereof;

FIG. 74 is a top, right, rear perspective view thereof;

FIG. 75 is a bottom, left, front perspective view thereof;

FIG. 76 is a bottom, left, rear perspective view thereof;

FIG. 77 is a front elevation view thereof;

FIG. 78 is a rear elevation view thereof;

FIG. 79 is a right side elevation view thereof;

FIG. 80 is a left side elevation view thereof;

FIG. 81 is a top plan view thereof;

FIG. 82 is a bottom plan view thereof;

FIG. 83 is an enlarged view of Region 83 of FIG. 72, as viewed from the top and right side of FIG. 72;

FIG. 84 is an enlarged view of Region 84 of FIG. 75, as viewed from the bottom and right side of FIG. 75;

FIG. 85 is a top, left, front perspective view of an electrically conductive contact according to another embodiment of my design;

FIG. 86 is a top, left, rear perspective view thereof;

FIG. 87 is a top, right, front perspective view thereof;

FIG. 88 is a top, right, rear perspective view thereof;

FIG. 89 is a bottom, left, front perspective view thereof;

FIG. 90 is a bottom, left, rear perspective view thereof;

FIG. 91 is a front elevation view thereof;

FIG. 92 is a rear elevation view thereof;

FIG. 93 is a right side elevation view thereof;

FIG. 94 is a left side elevation view thereof;

FIG. 95 is a top plan view thereof;

FIG. 96 is a bottom plan view thereof;

FIG. 97 is an enlarged view of Region 97 of FIG. 86, as viewed from the top, front, and right side of FIG. 86;

FIG. 98 is an enlarged view of Region 98 of FIG. 89, as viewed from the bottom and right side of FIG. 89;

FIG. 99 is a top, left, front perspective view of an electrically conductive contact according to another embodiment of my design;

FIG. 100 is a top, left, rear perspective view thereof;

FIG. 101 is a top, right, front perspective view thereof;

FIG. 102 is a top, right, rear perspective view thereof;

FIG. 103 is a bottom, left, front perspective view thereof;

FIG. 104 is a bottom, left, rear perspective view thereof;

FIG. 105 is a front elevation view thereof;

FIG. 106 is a rear elevation view thereof;

FIG. 107 is a right side elevation view thereof;

FIG. 108 is a left side elevation view thereof;

FIG. 109 is a top plan view thereof;

FIG. 110 is a bottom plan view thereof;

FIG. 111 is an enlarged view of Region 111 of FIG. 100, as viewed from the top, front, and right side of FIG. 100;

FIG. 112 is an enlarged view of Region 112 of FIG. 103, as viewed from the bottom and right side of FIG. 103;

FIG. 113 is a top, left, front perspective view of an electrically conductive contact according to another embodiment of my design;

FIG. 114 is a top, left, rear perspective view thereof;

FIG. 115 is a top, right, front perspective view thereof;

FIG. 116 is a top, right, rear perspective view thereof;

FIG. 117 is a bottom, left, front perspective view thereof;

FIG. 118 is a bottom, left, rear perspective view thereof;

FIG. 119 is a front elevation view thereof;

FIG. 120 is a rear elevation view thereof;

FIG. 121 is a right side elevation view thereof;

FIG. 122 is a left side elevation view thereof;

FIG. 123 is a top plan view thereof;

FIG. 124 is a bottom plan view thereof;

FIG. 125 is an enlarged view of Region 114, as viewed from the top, front, and right side of FIG. 114;

FIG. 126 is an enlarged view of Region 126 of FIG. 117, as viewed from the bottom and right side of FIG. 117;

FIG. 127 is a top, left, front perspective view of an electrically conductive contact according to another embodiment of my design;

FIG. 128 is a top, left, rear perspective view thereof;

FIG. 129 is a top, right, front perspective view thereof;
FIG. 130 is a top, right, rear perspective view thereof;
FIG. 131 is a bottom, left, front perspective view thereof;
FIG. 132 is a bottom, left, rear perspective view thereof;
FIG. 133 is a front elevation view thereof;
FIG. 134 is a rear elevation view thereof;
FIG. 135 is a right side elevation view thereof;
FIG. 136 is a left side elevation view thereof;
FIG. 137 is a top plan view thereof;
FIG. 138 is a bottom plan view thereof;
FIG. 139 is an enlarged view of Region 139 of FIG. 128, as viewed from the top, front, and right side of FIG. 128;
FIG. 140 is an enlarged view of Region 140 of FIG. 131 as viewed from the bottom and right side of FIG. 131;
FIG. 141 is a top, left, front perspective view of an electrically conductive contact according to another embodiment of my design;
FIG. 142 is a top, left, rear perspective view thereof;
FIG. 143 is a top, right, front perspective view thereof;
FIG. 144 is a top, right, rear perspective view thereof;
FIG. 145 is a bottom, left, front perspective view thereof;
FIG. 146 is a bottom, left, rear perspective view thereof;
FIG. 147 is a front elevation view thereof;
FIG. 148 is a rear elevation view thereof;
FIG. 149 is a right side elevation view thereof;
FIG. 150 is a left side elevation view thereof;
FIG. 151 is a top plan view thereof;
FIG. 152 is a bottom plan view thereof;
FIG. 153 is an enlarged view of Region 153 of FIG. 142, as viewed from the top, front, and right side of FIG. 142;

FIG. 154 is an enlarged view of Region 154 of FIG. 145, as viewed from the bottom and right side of FIG. 145;
FIG. 155 is a top, left, front perspective view of an electrically conductive contact according to another embodiment of my design;
FIG. 156 is a top, left, rear perspective view thereof;
FIG. 157 is a top, right, front perspective view thereof;
FIG. 158 is a top, right, rear perspective view thereof;
FIG. 159 is a bottom, left, front perspective view thereof;
FIG. 160 is a bottom, left, rear perspective view thereof;
FIG. 161 is a front elevation view thereof;
FIG. 162 is a rear elevation view thereof;
FIG. 163 is a right side elevation view thereof;
FIG. 164 is a left side elevation view thereof;
FIG. 165 is a top plan view thereof;
FIG. 166 is a bottom plan view thereof;
FIG. 167 is an enlarged view of Region 167 of FIG. 156, as viewed from the top, front, and right side of FIG. 156; and,
FIG. 168 is an enlarged view of Region 168 of FIG. 159, as viewed from the bottom, rear, and right side of FIG. 159.
The broken line portion of the figure drawings is included to show unclaimed subject matter only for the purpose of illustrating environment and forms no part of the claimed design.
In a preferred embodiment, the nature of this product is an electrically conductive contact for use in an electrical connector.

1 Claim, 72 Drawing Sheets

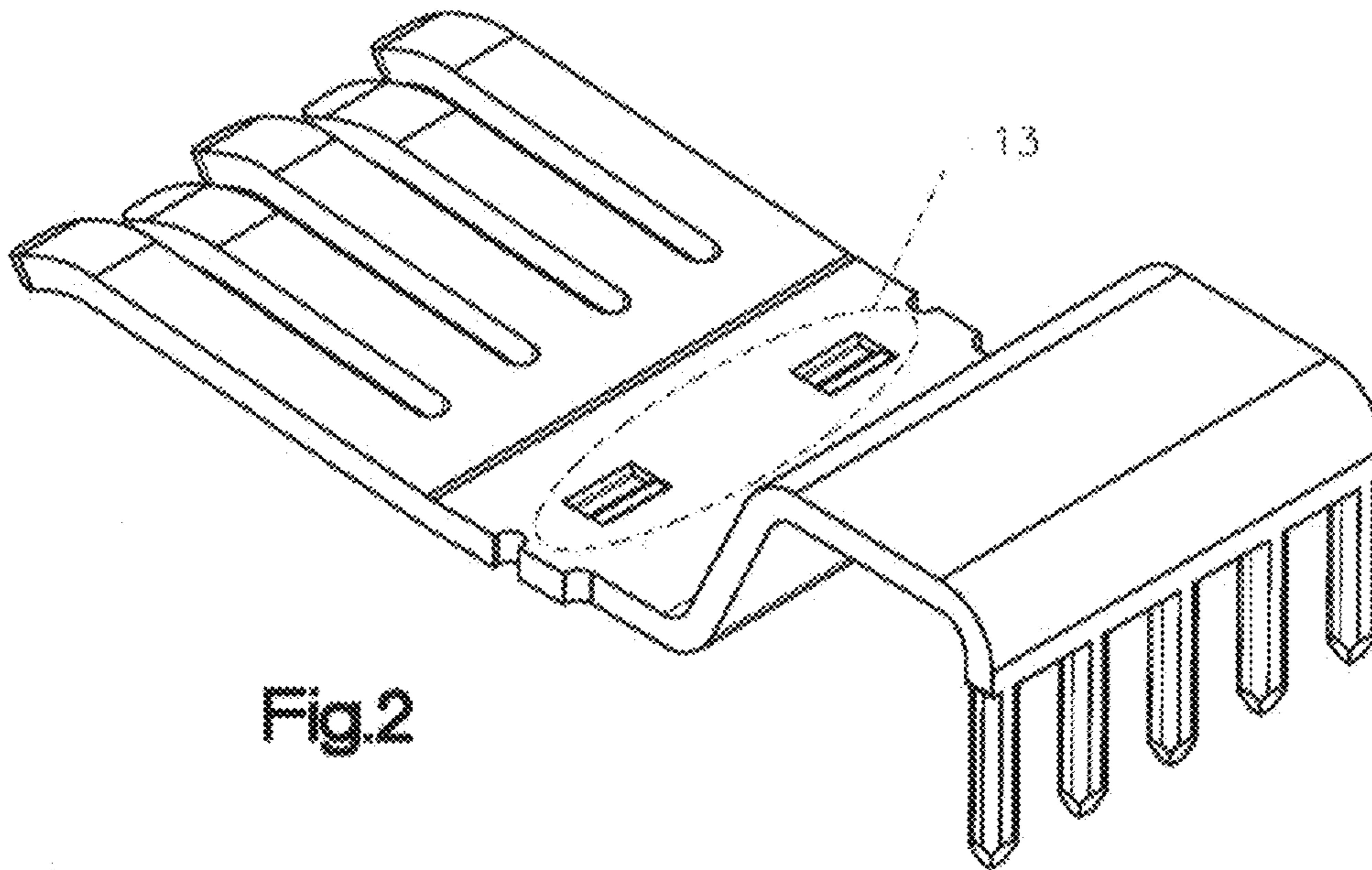
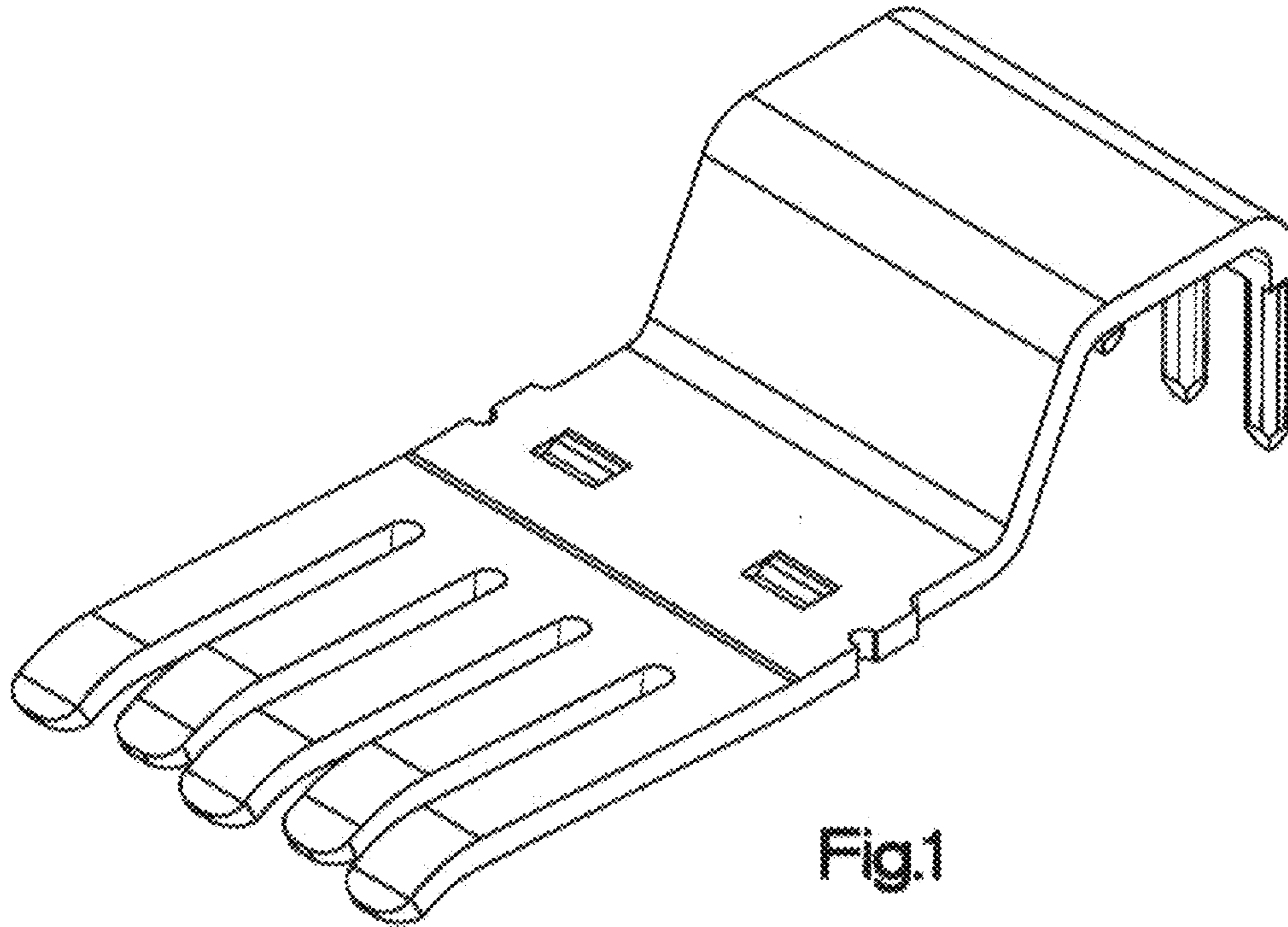

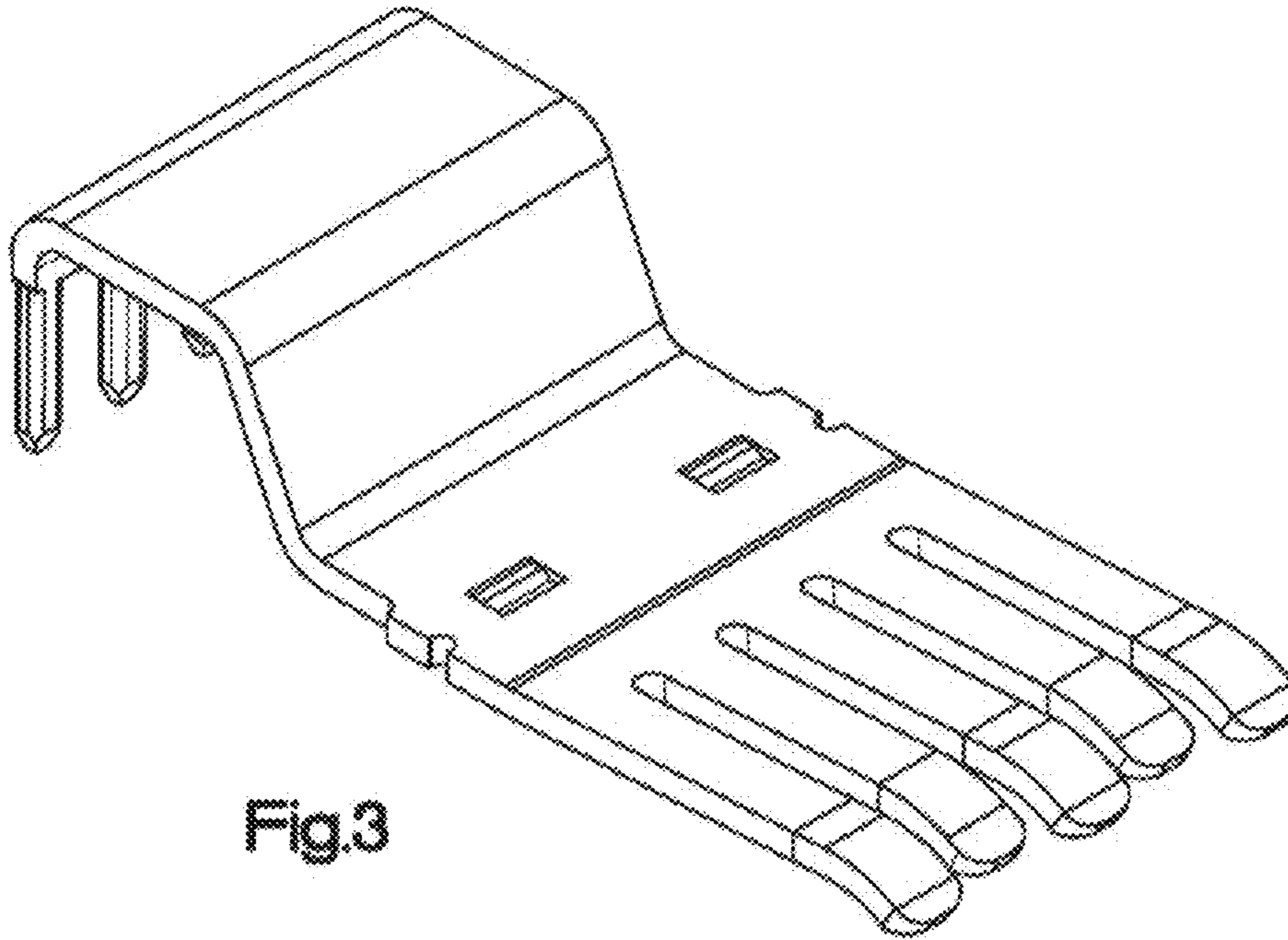

Fig.3

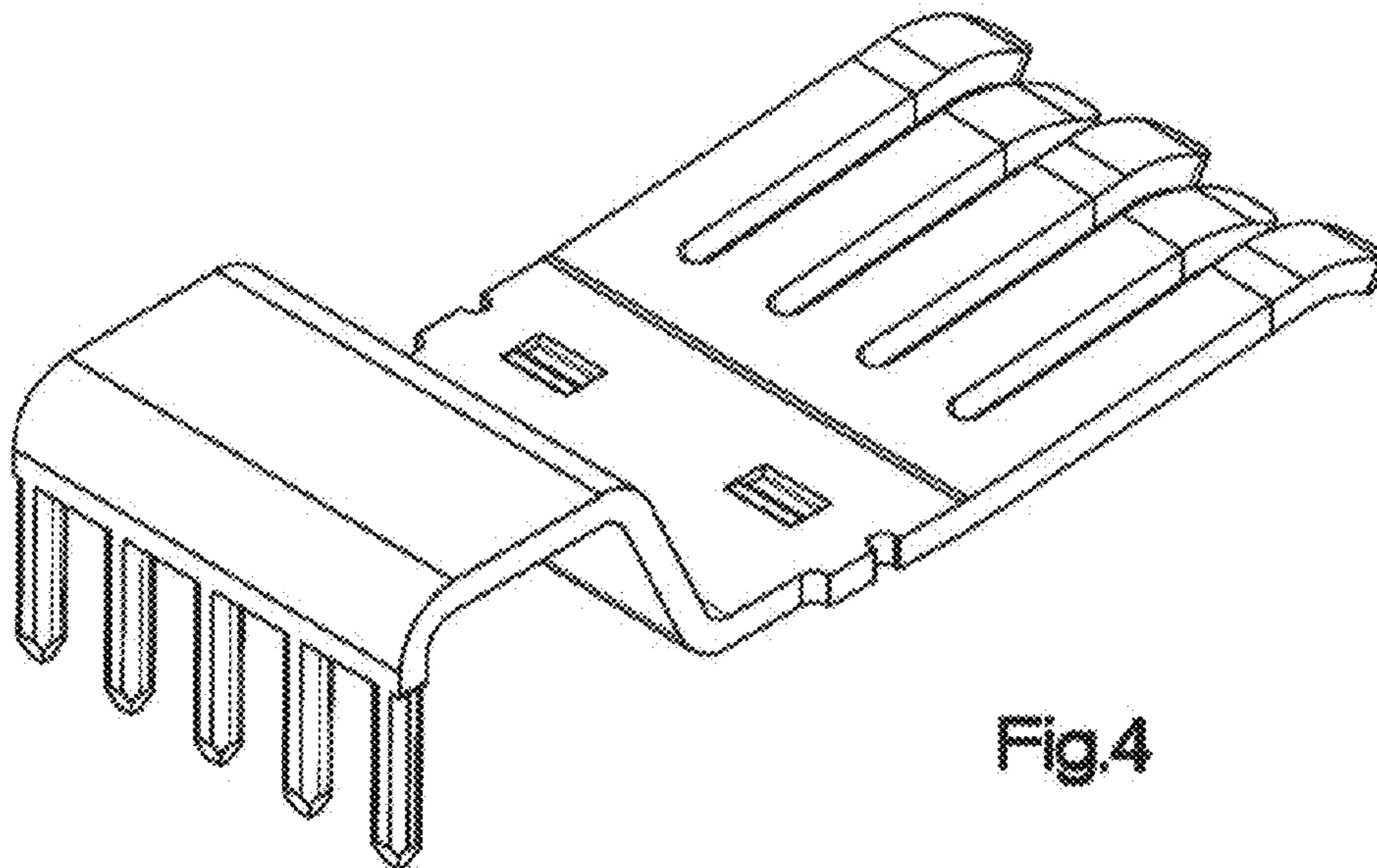
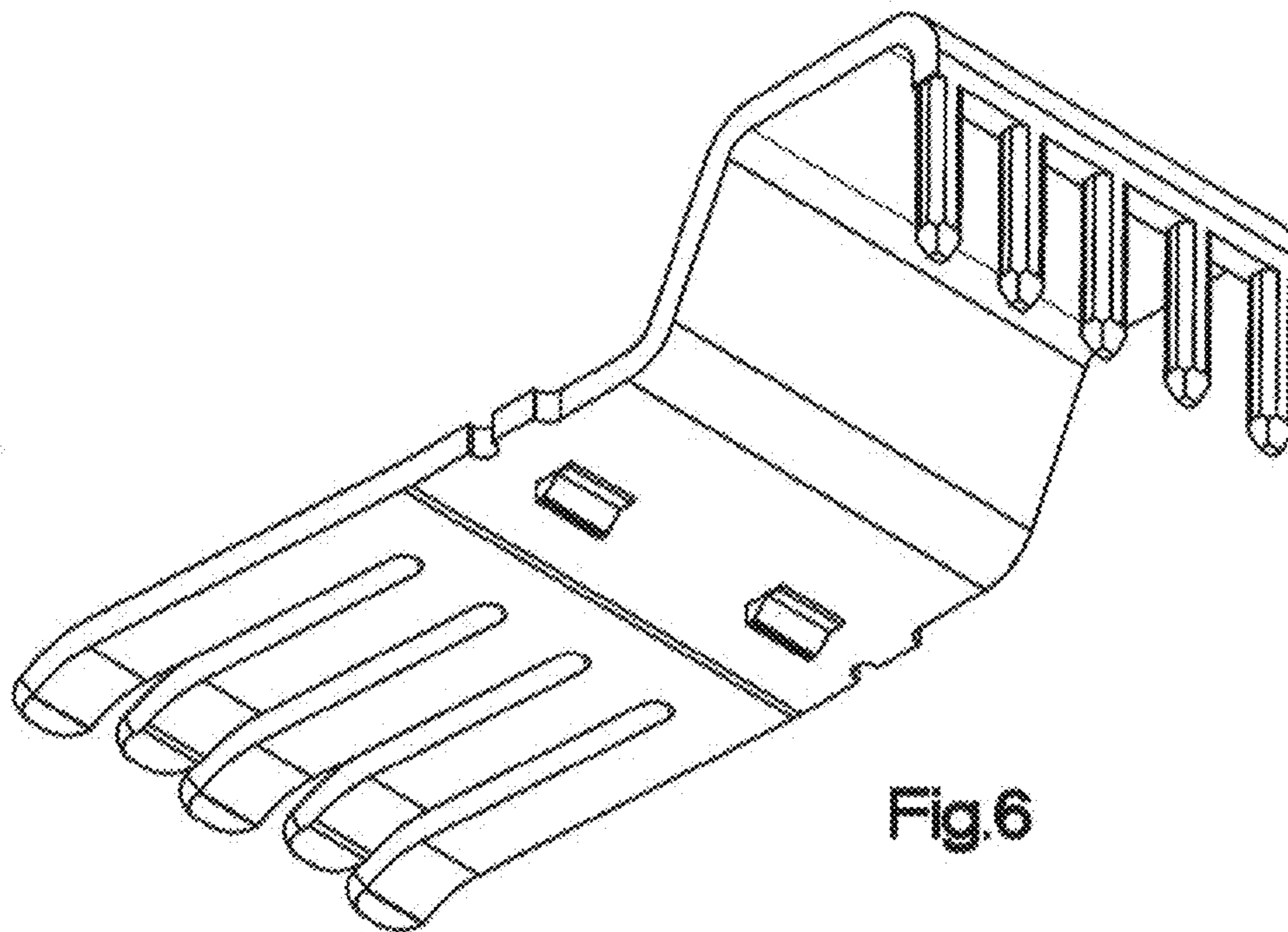
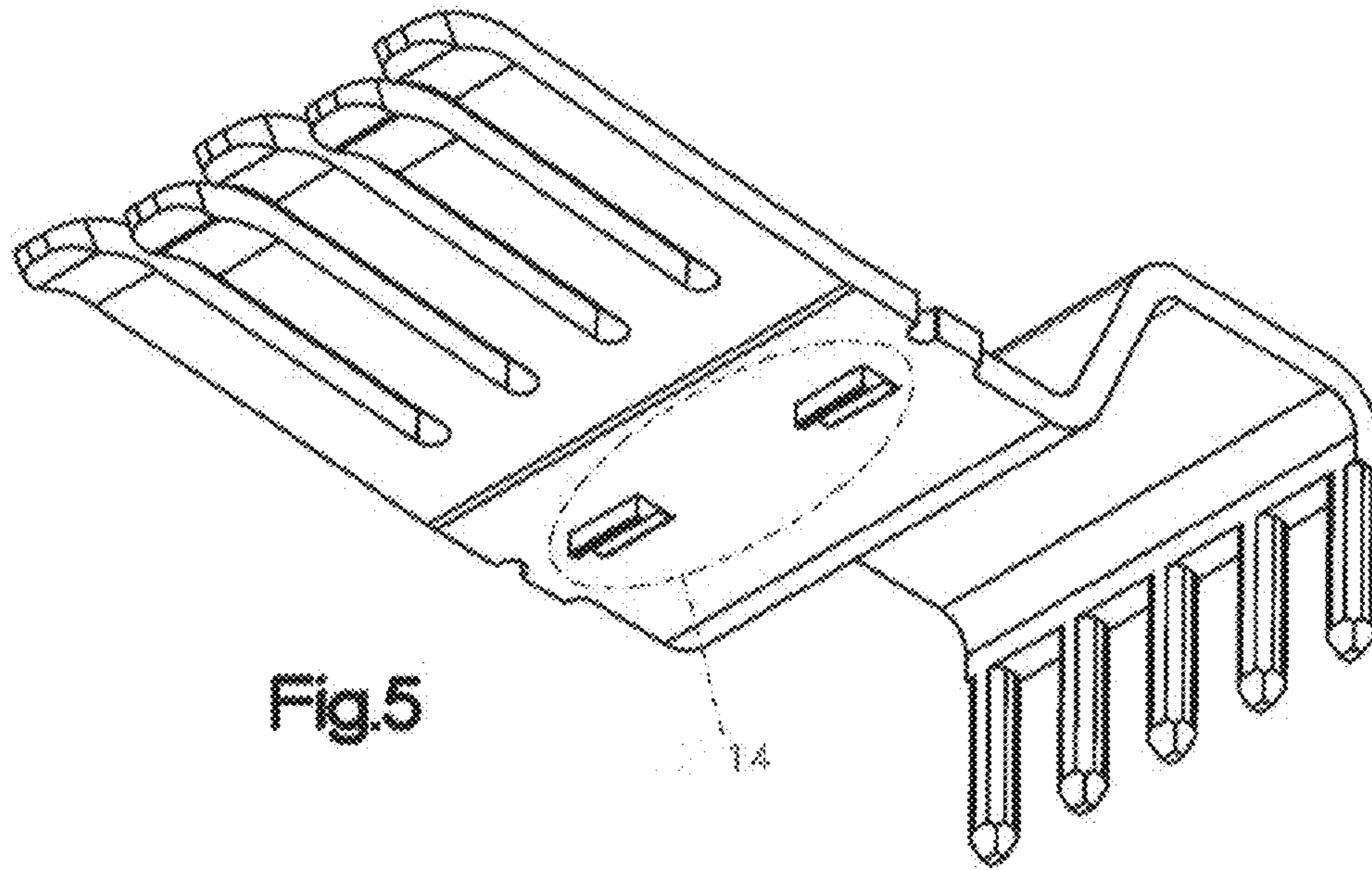

Fig.4



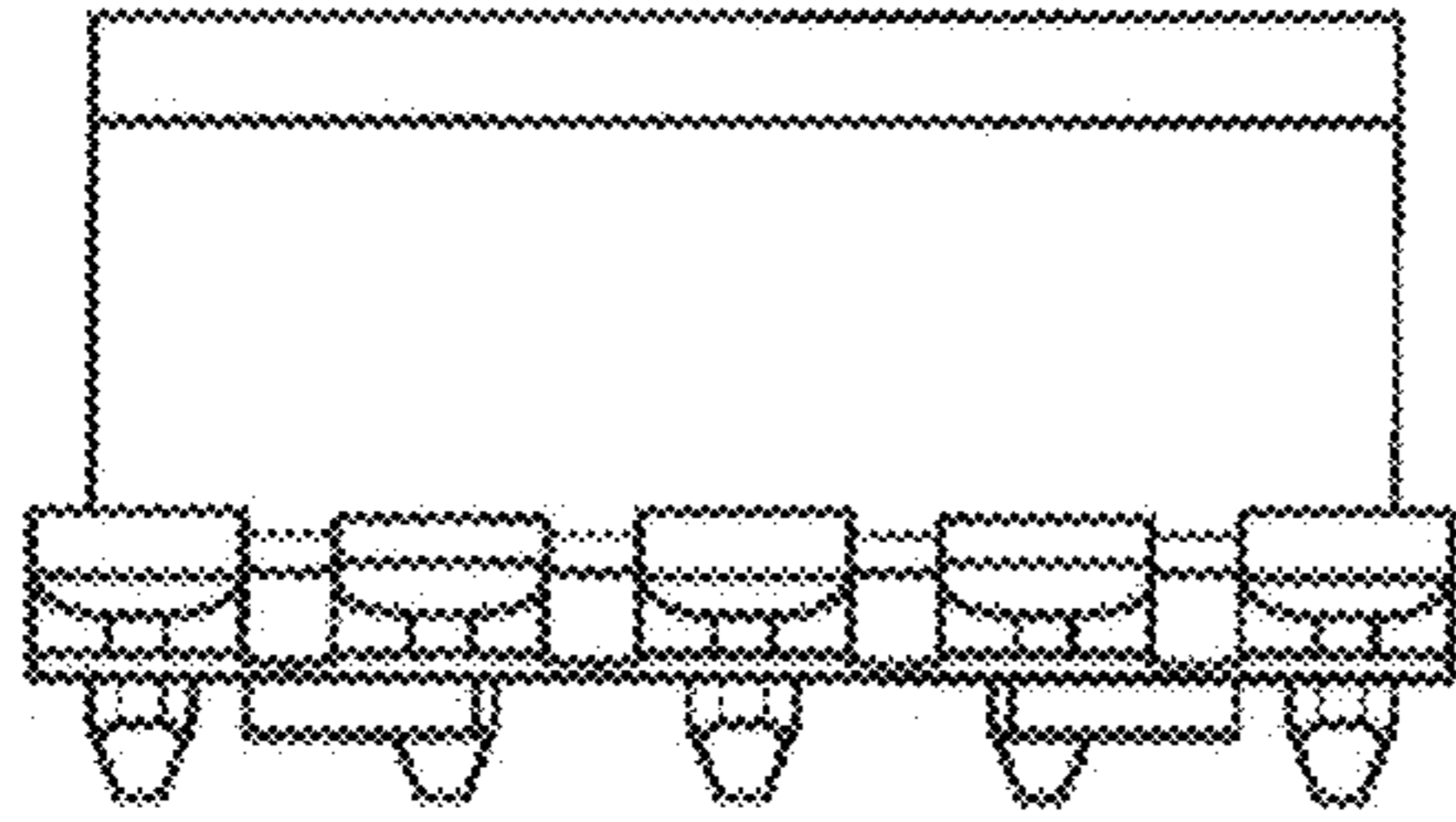

Fig.7

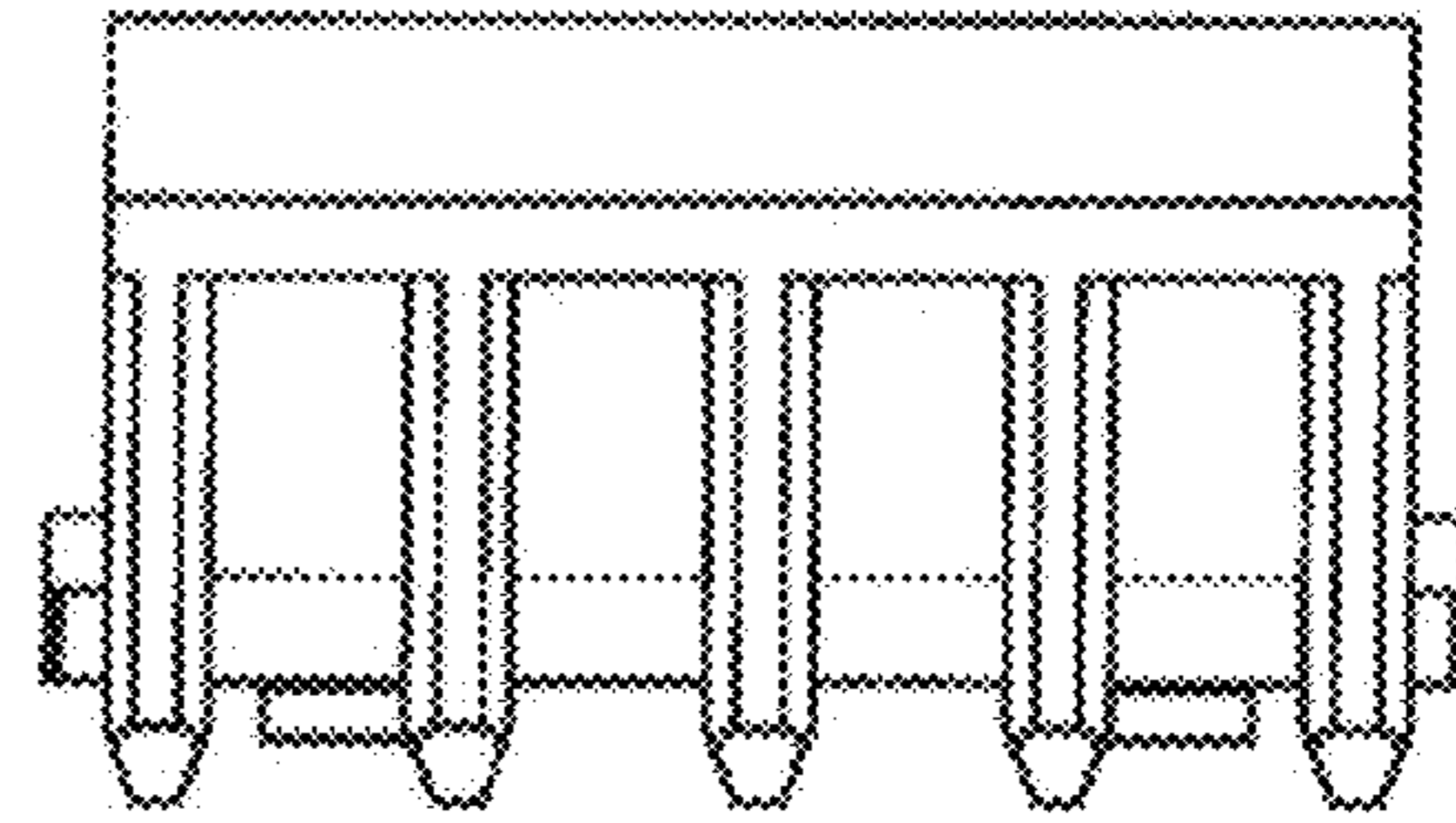

Fig.8

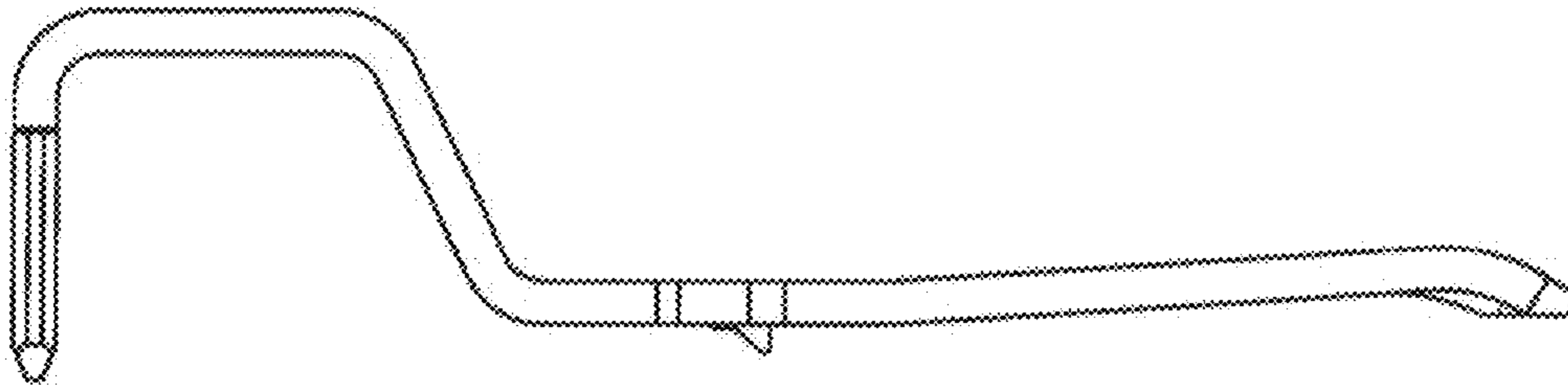

Fig.9

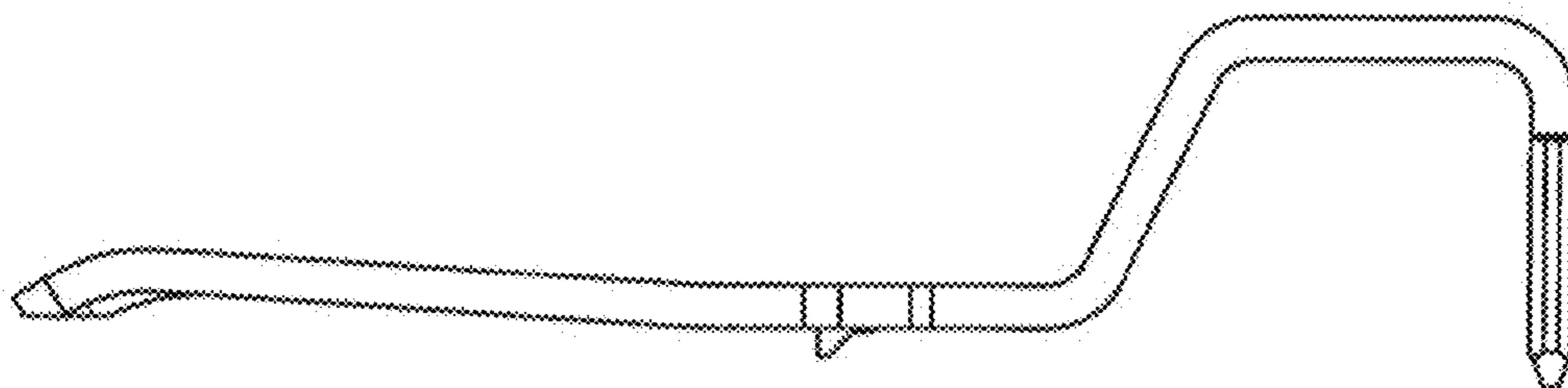

Fig.10

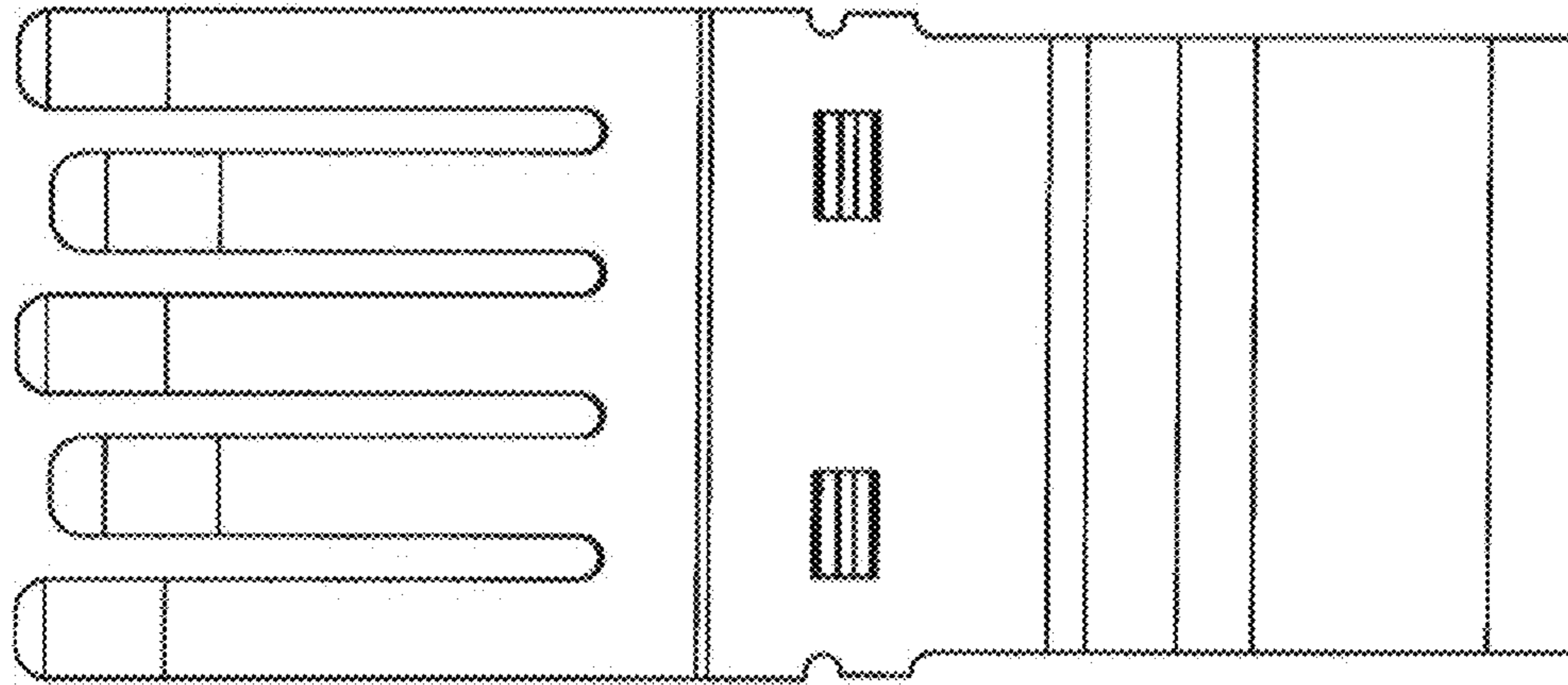

Fig.11

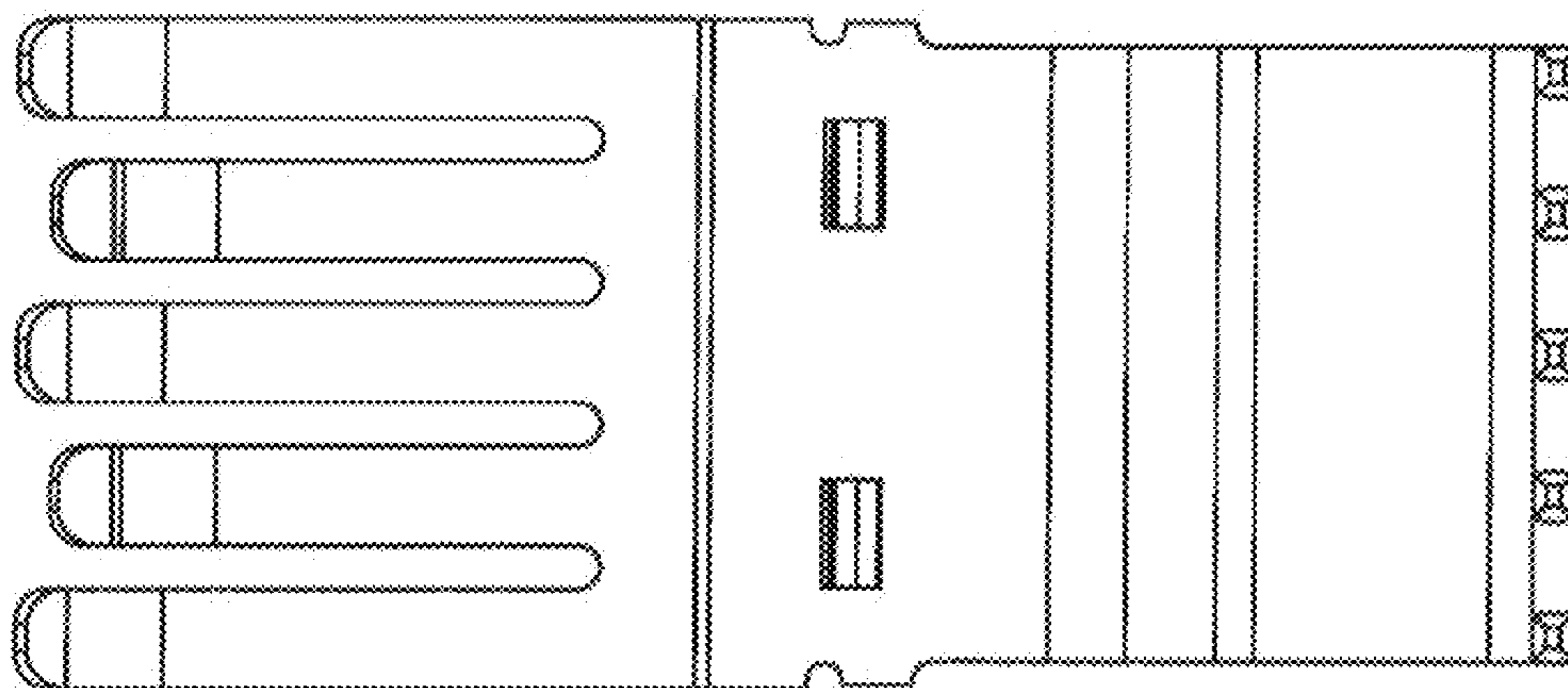

Fig.12

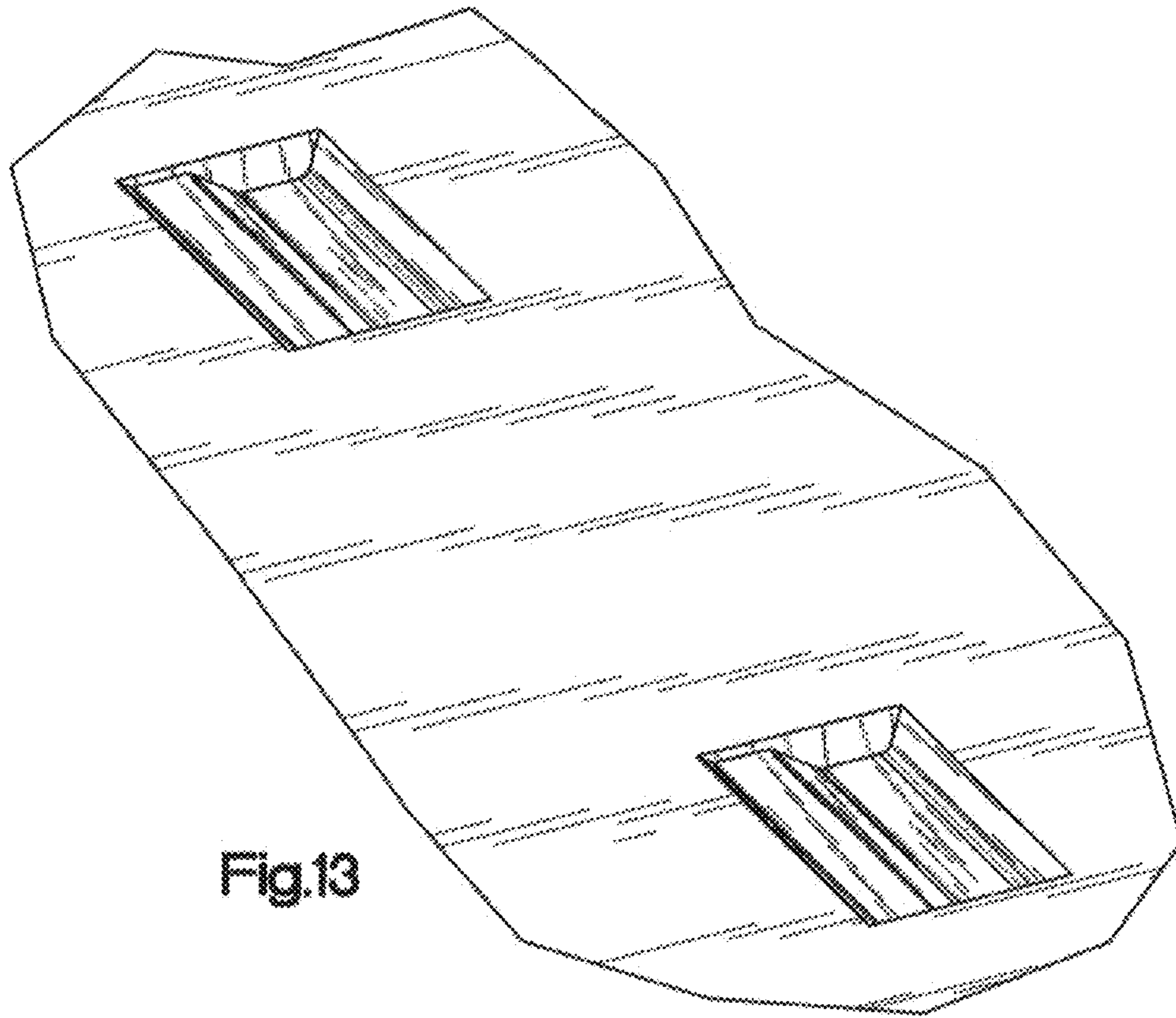

Fig.13

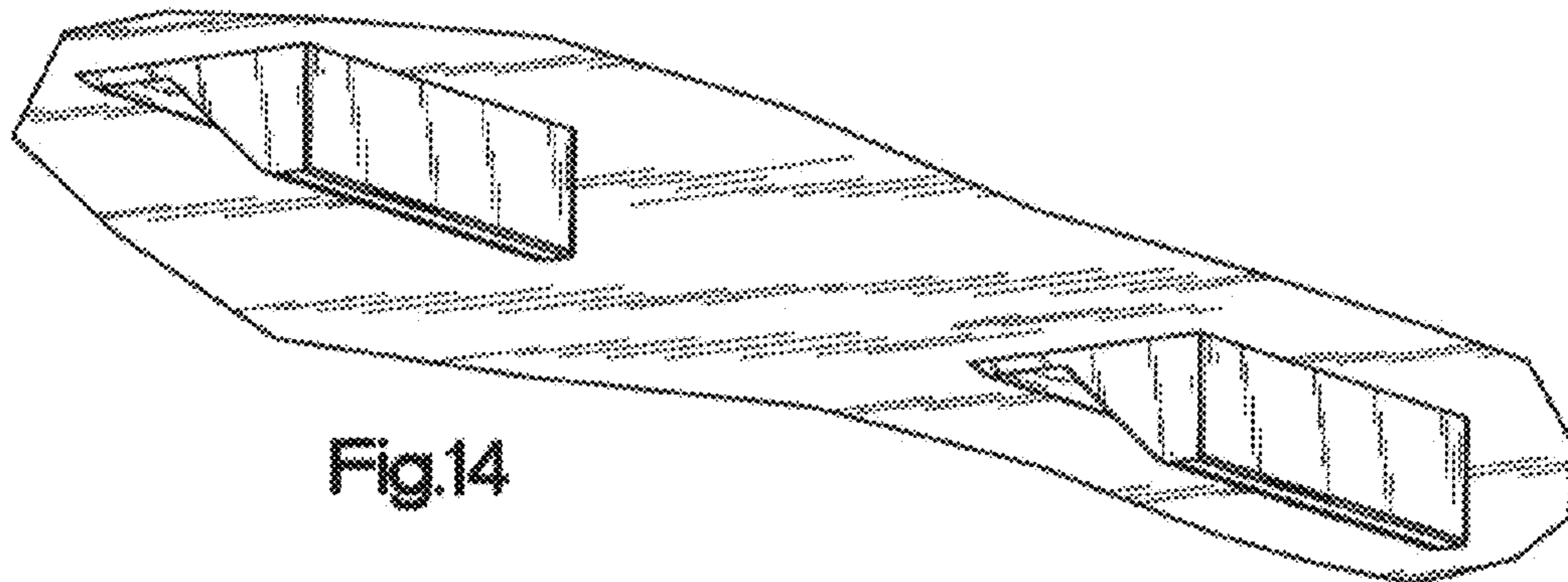

Fig.14

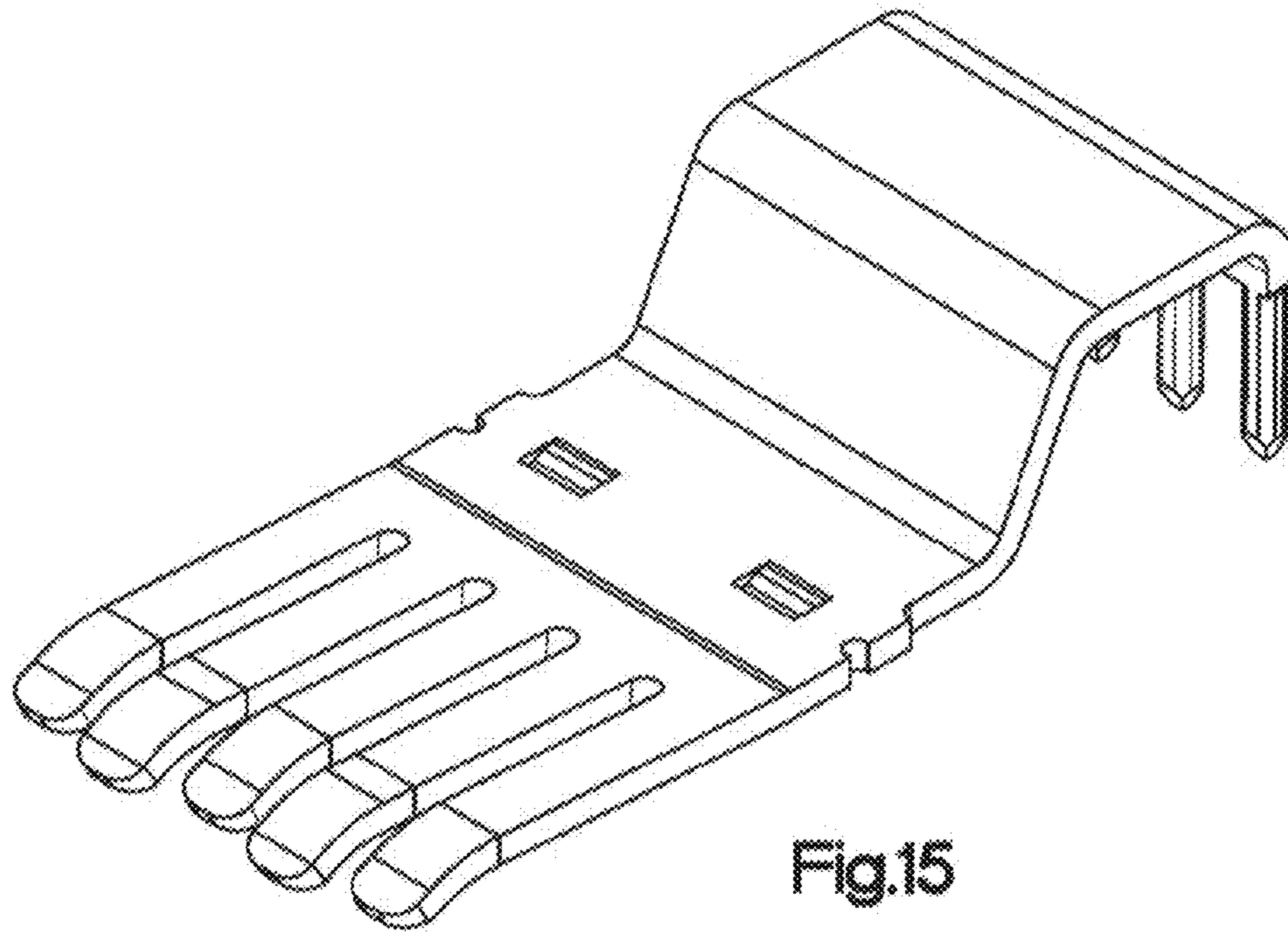

Fig.15

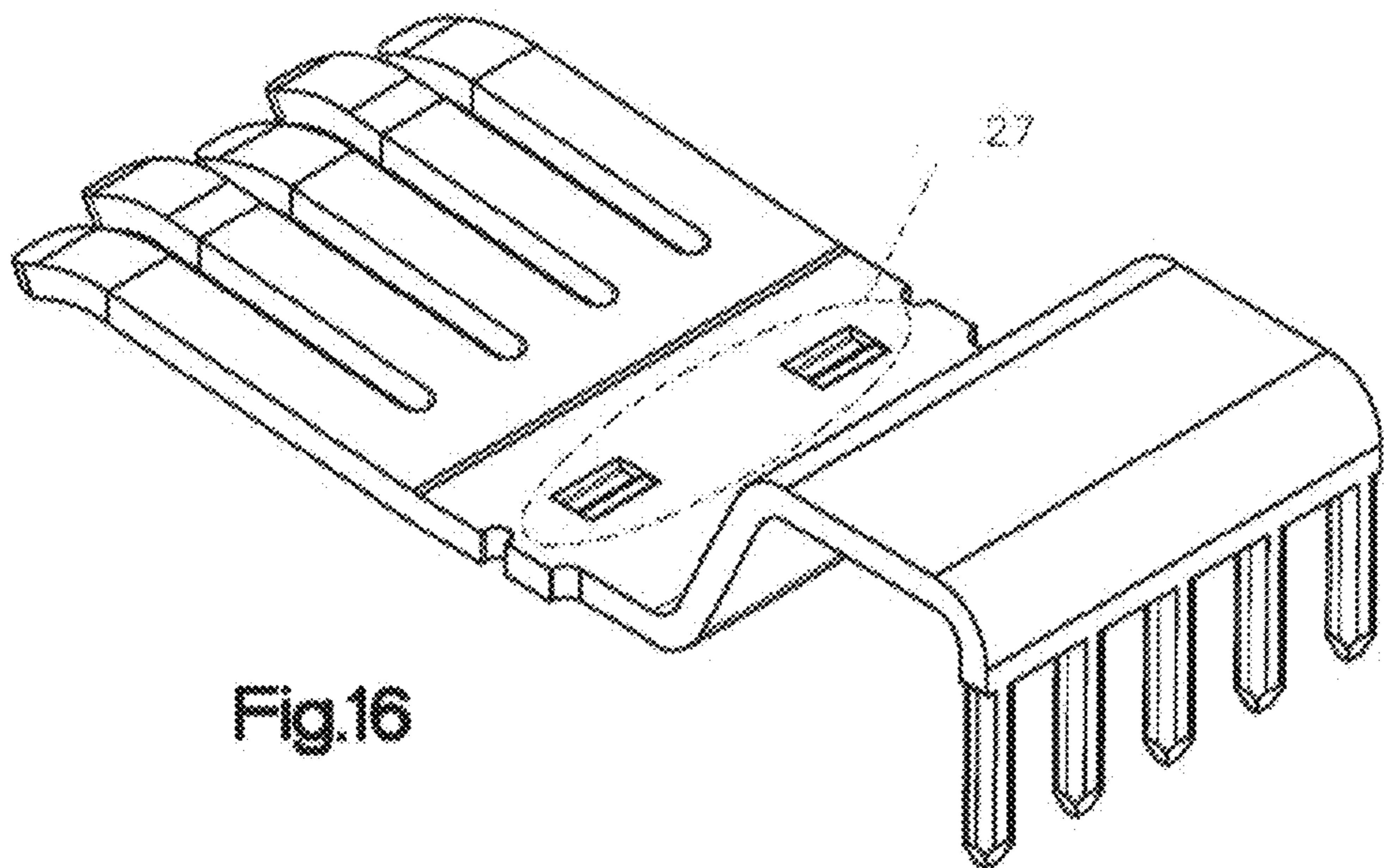

Fig.16

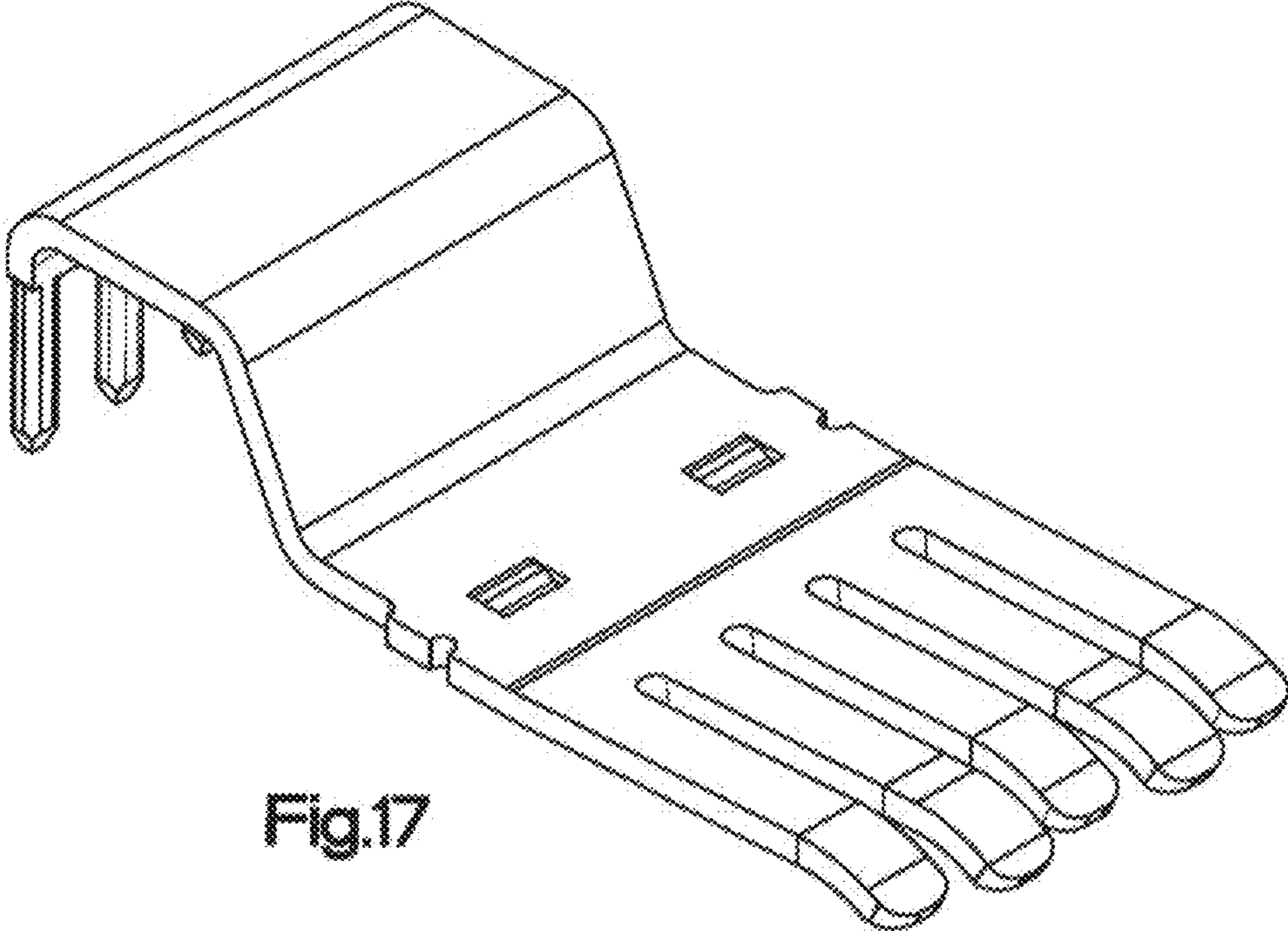

Fig.17

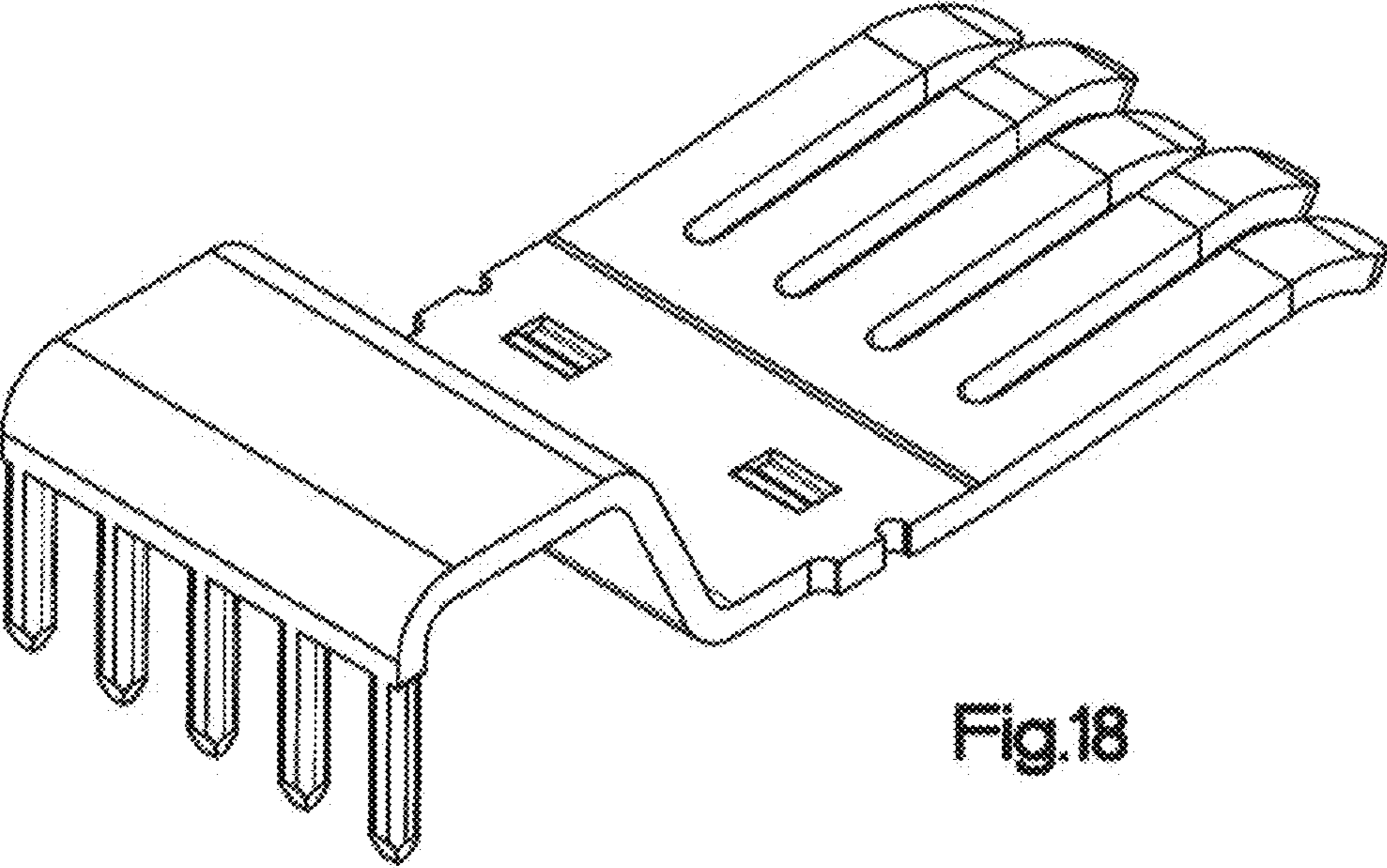
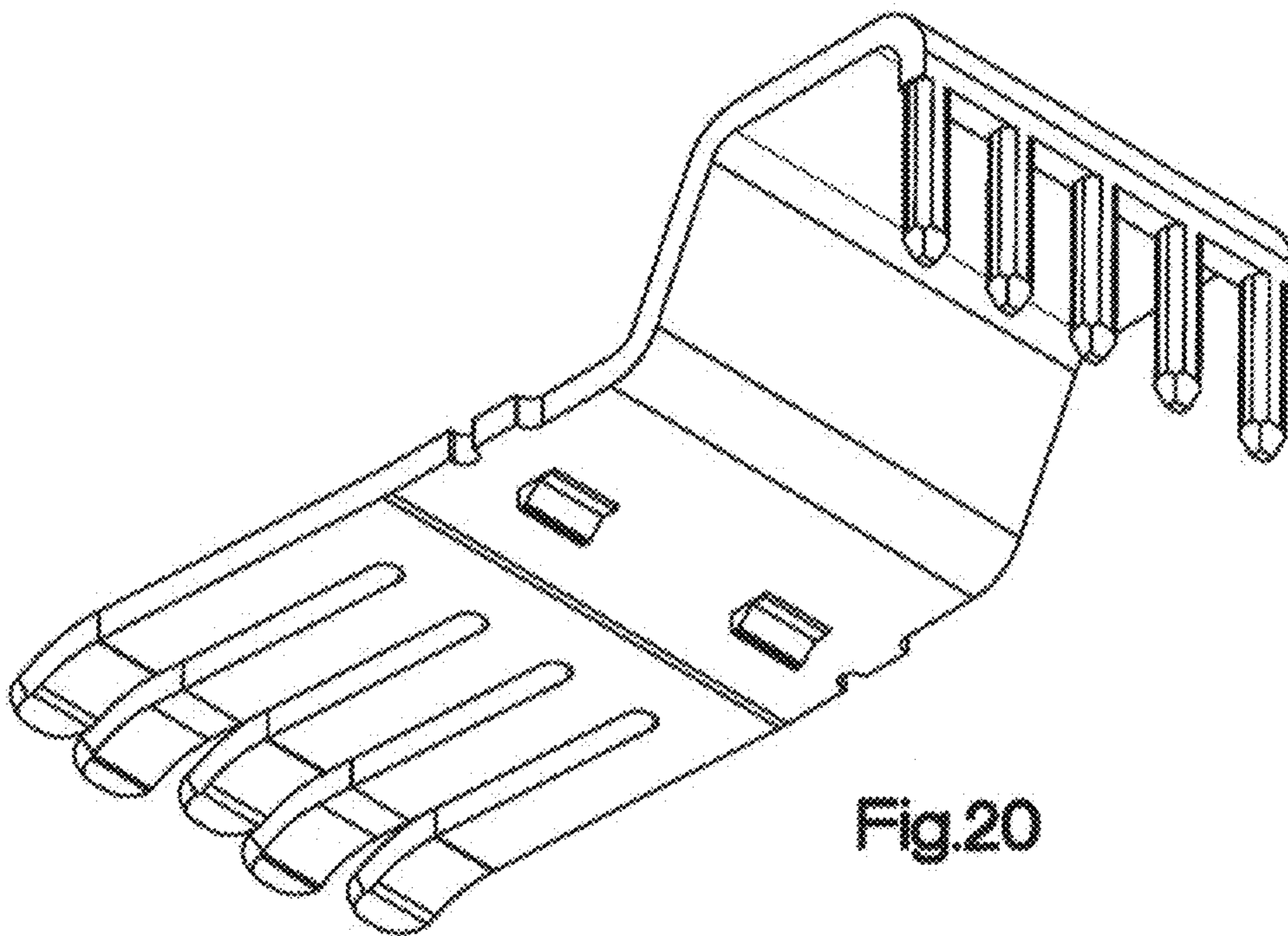
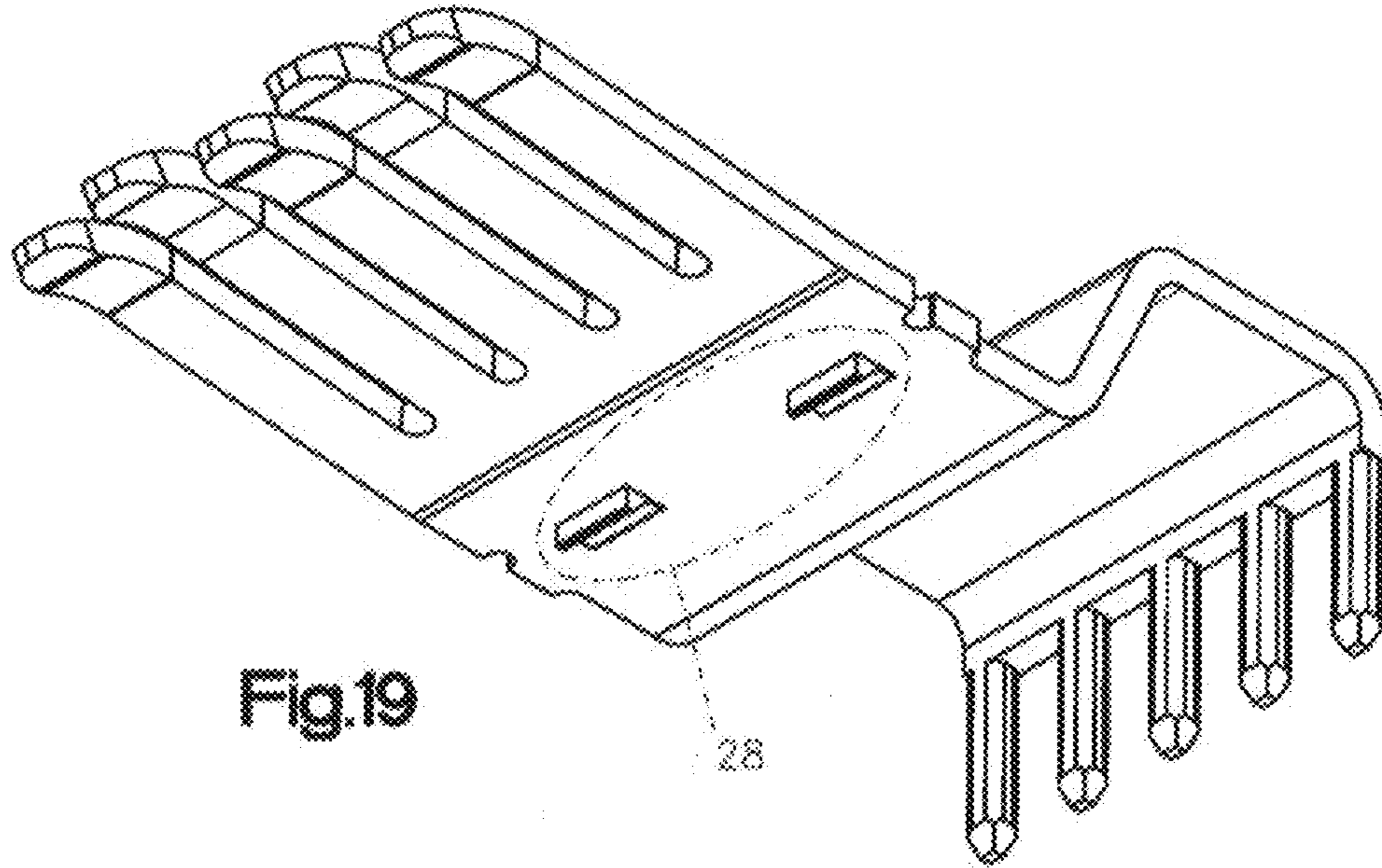

Fig.18



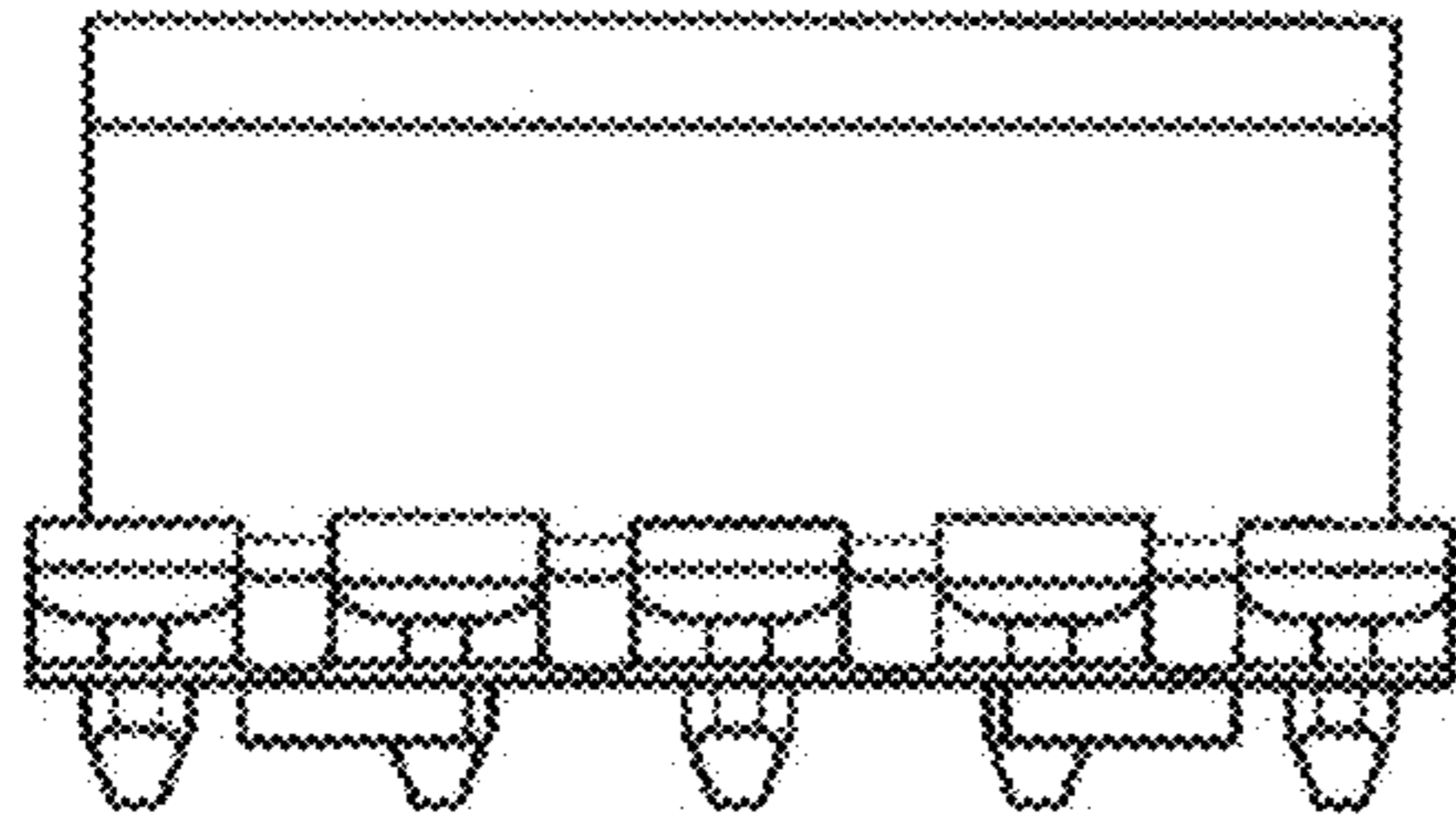

Fig.21

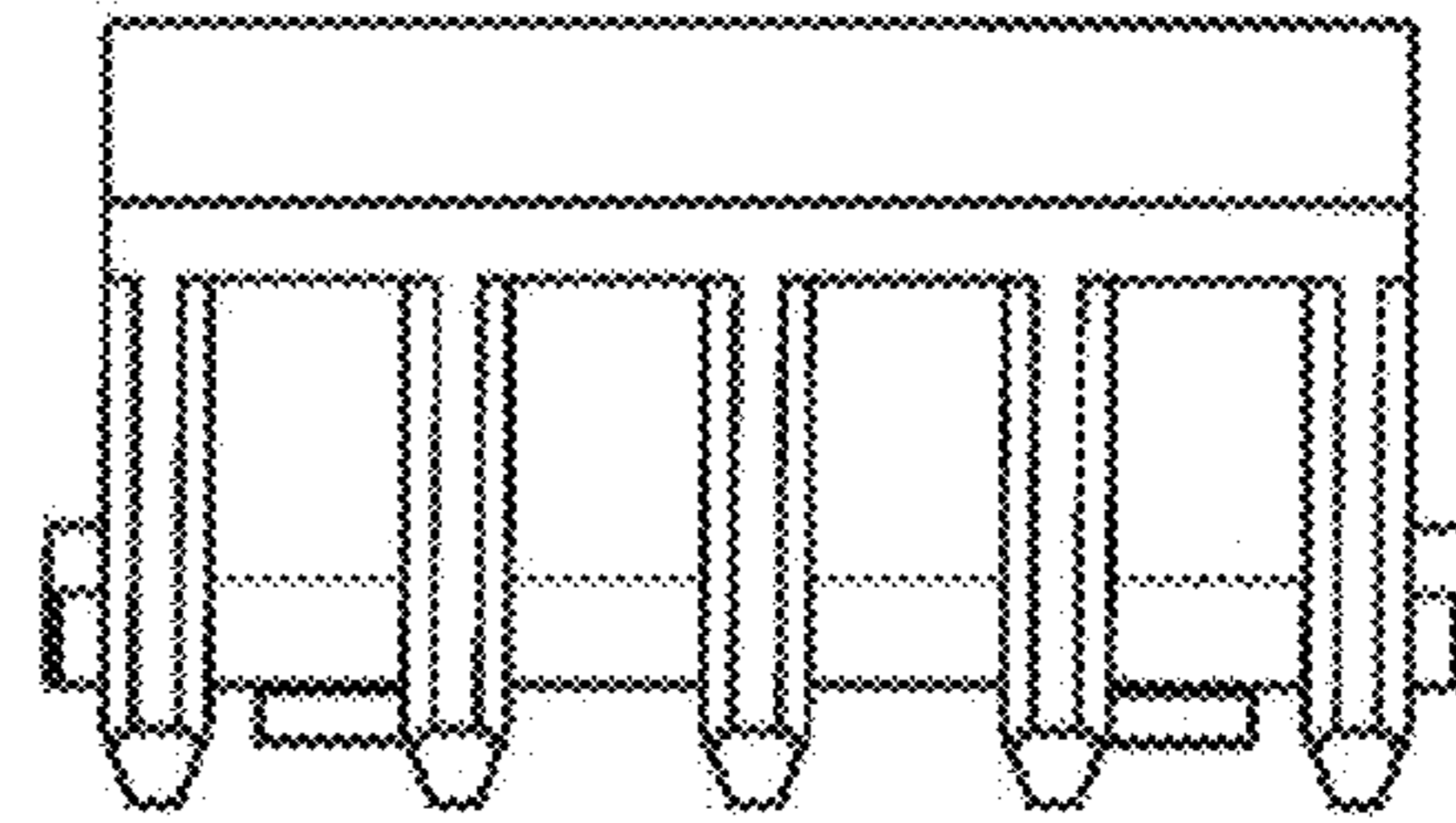

Fig.22

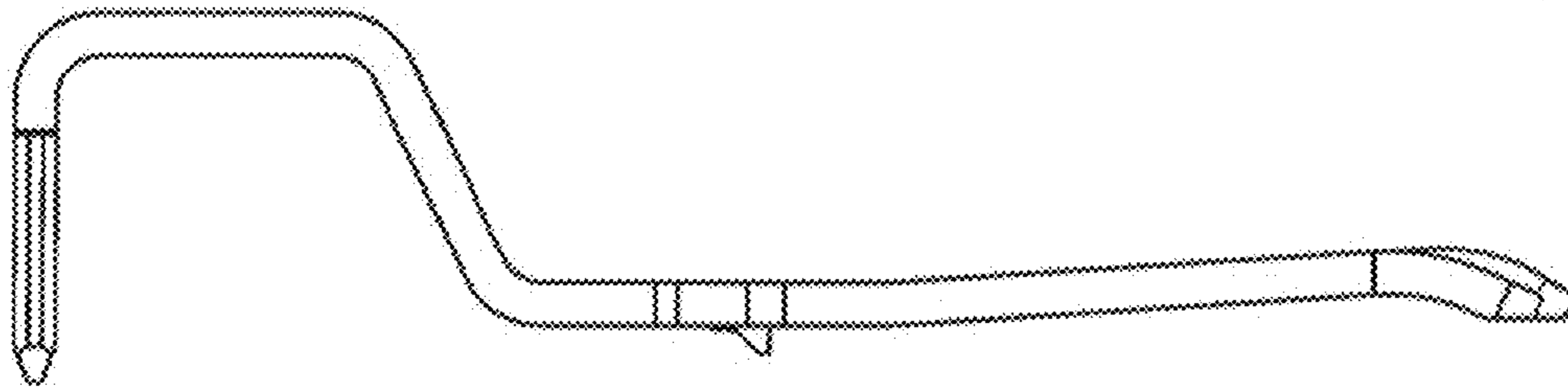

Fig.23

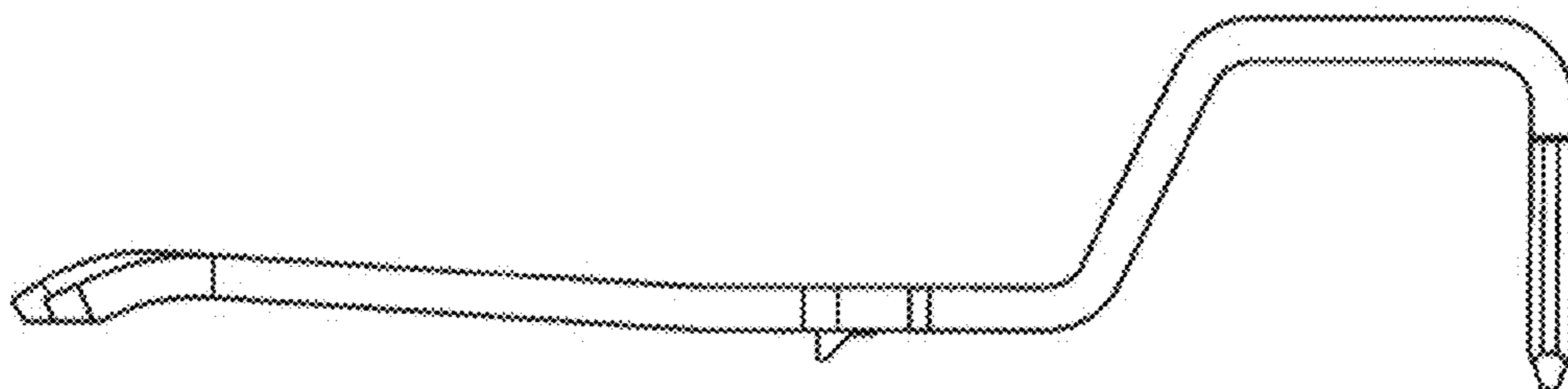

Fig.24

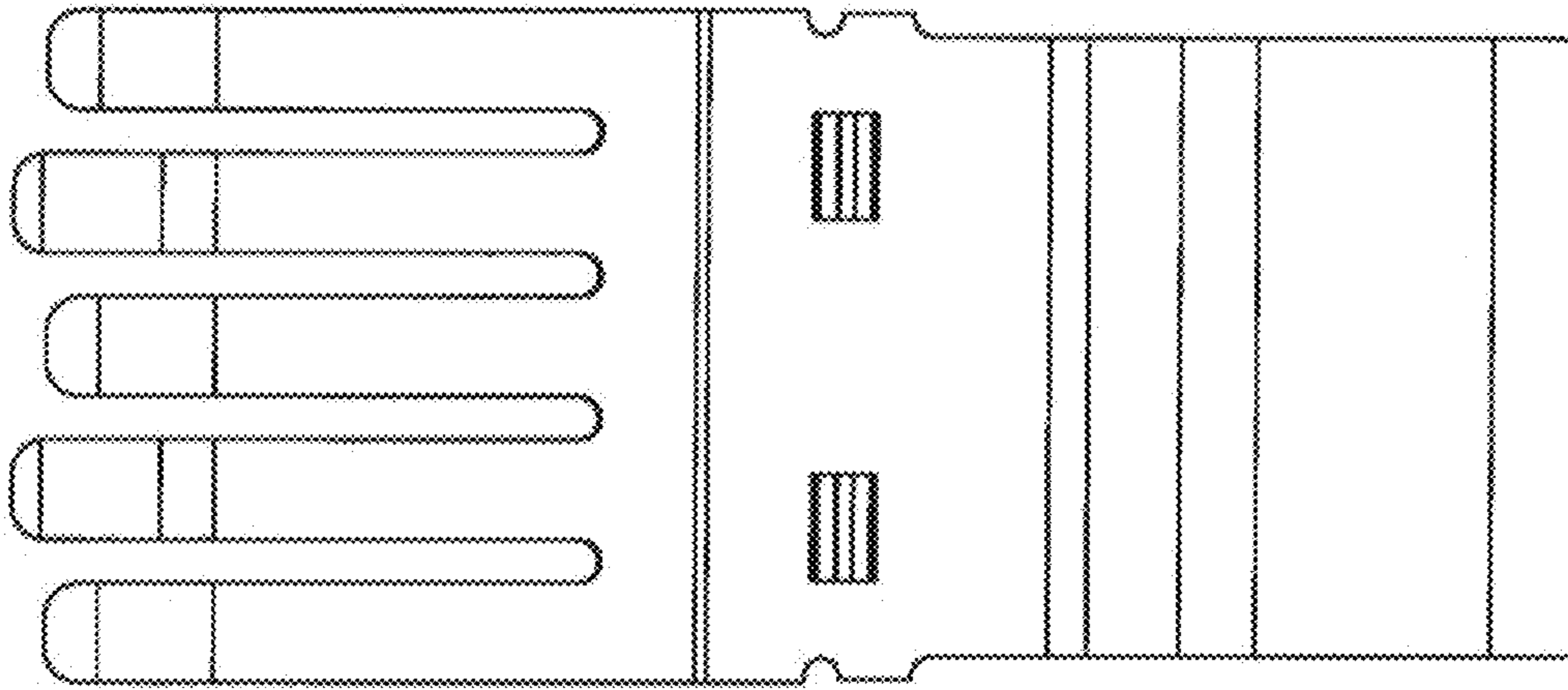

Fig.25

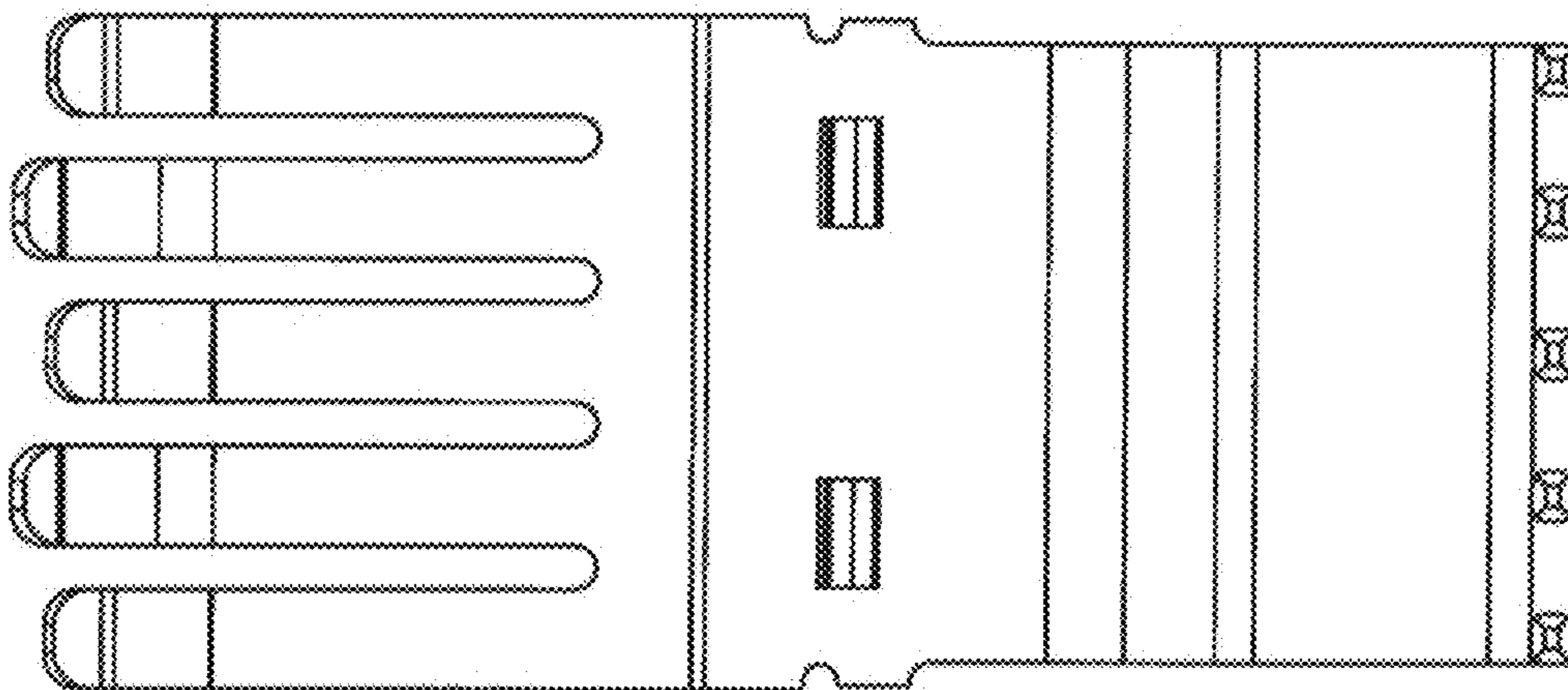

Fig.26

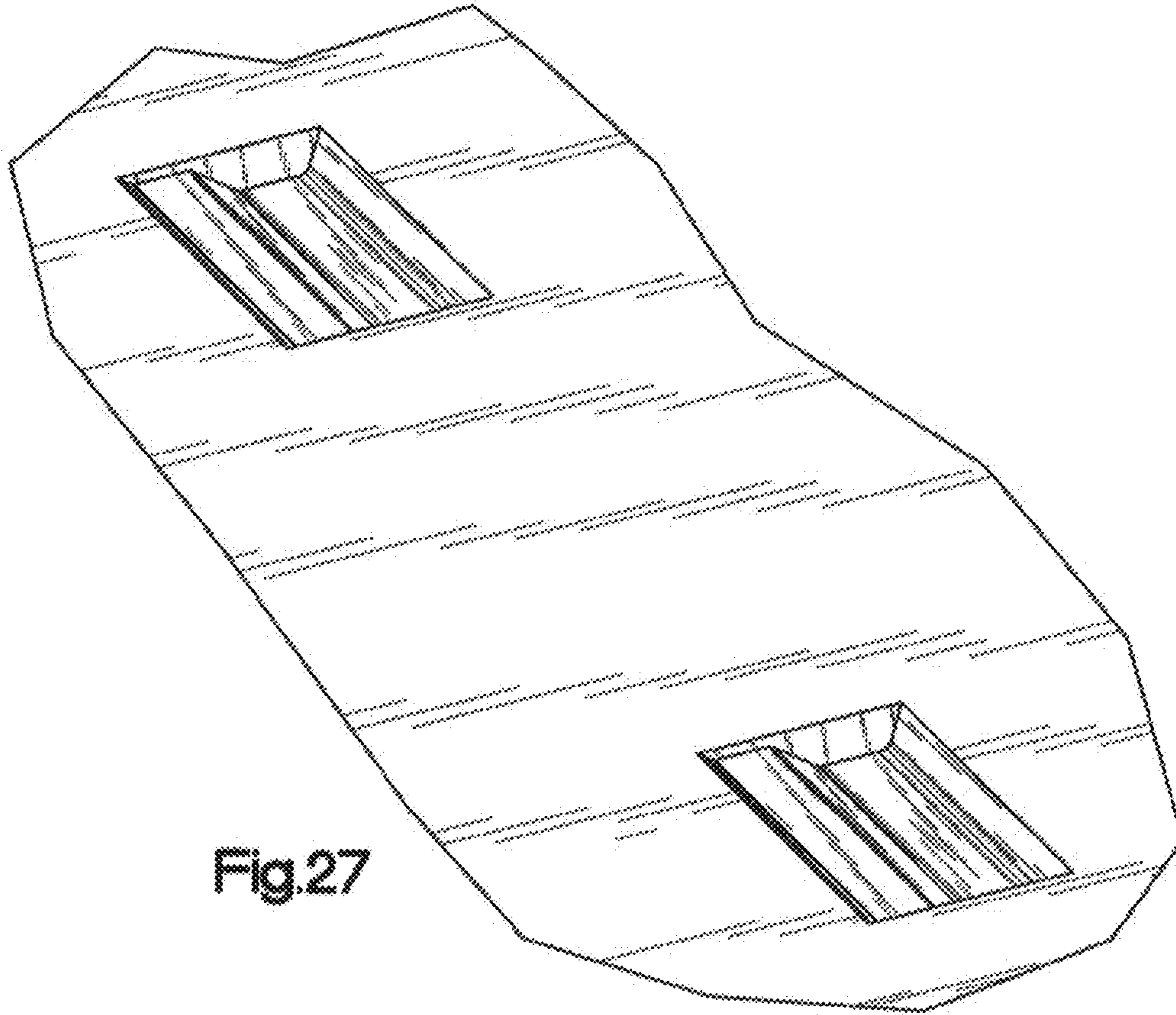

Fig.27

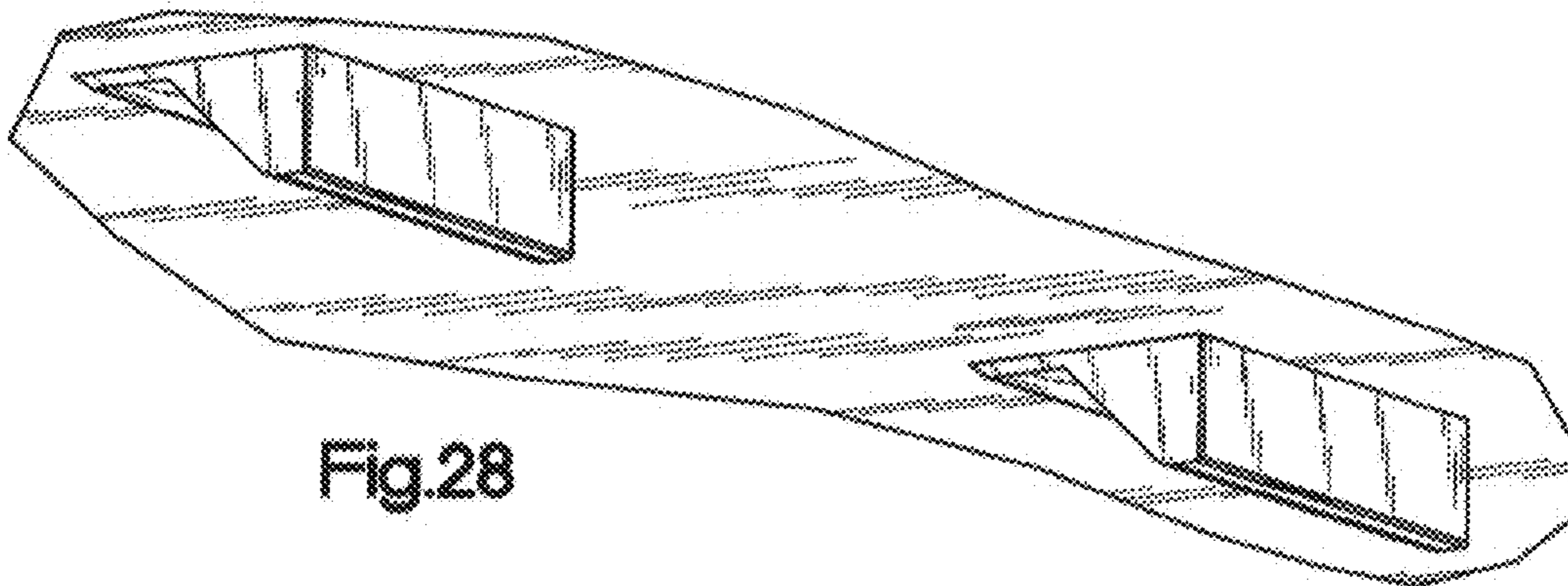

Fig.28

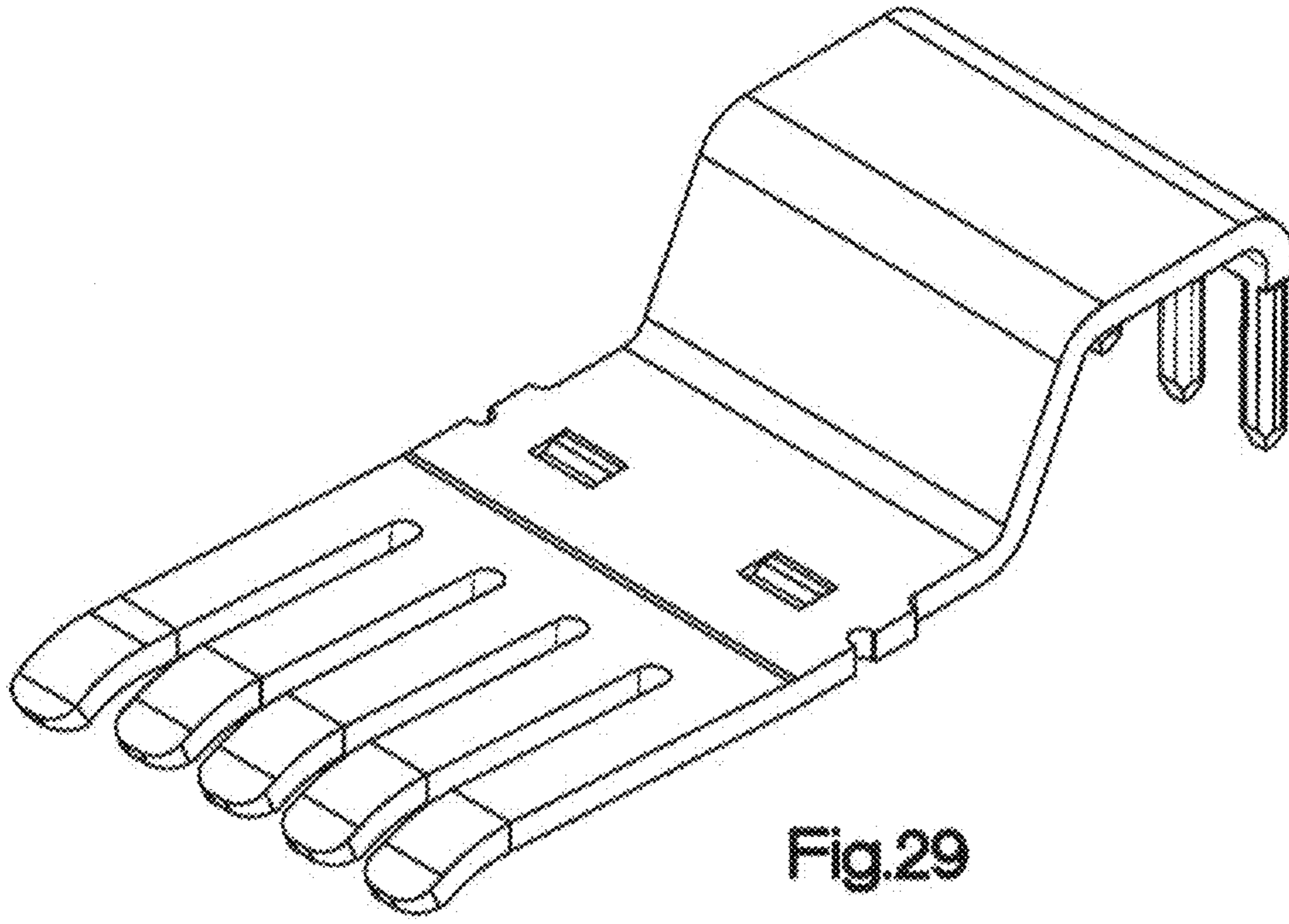

Fig.29

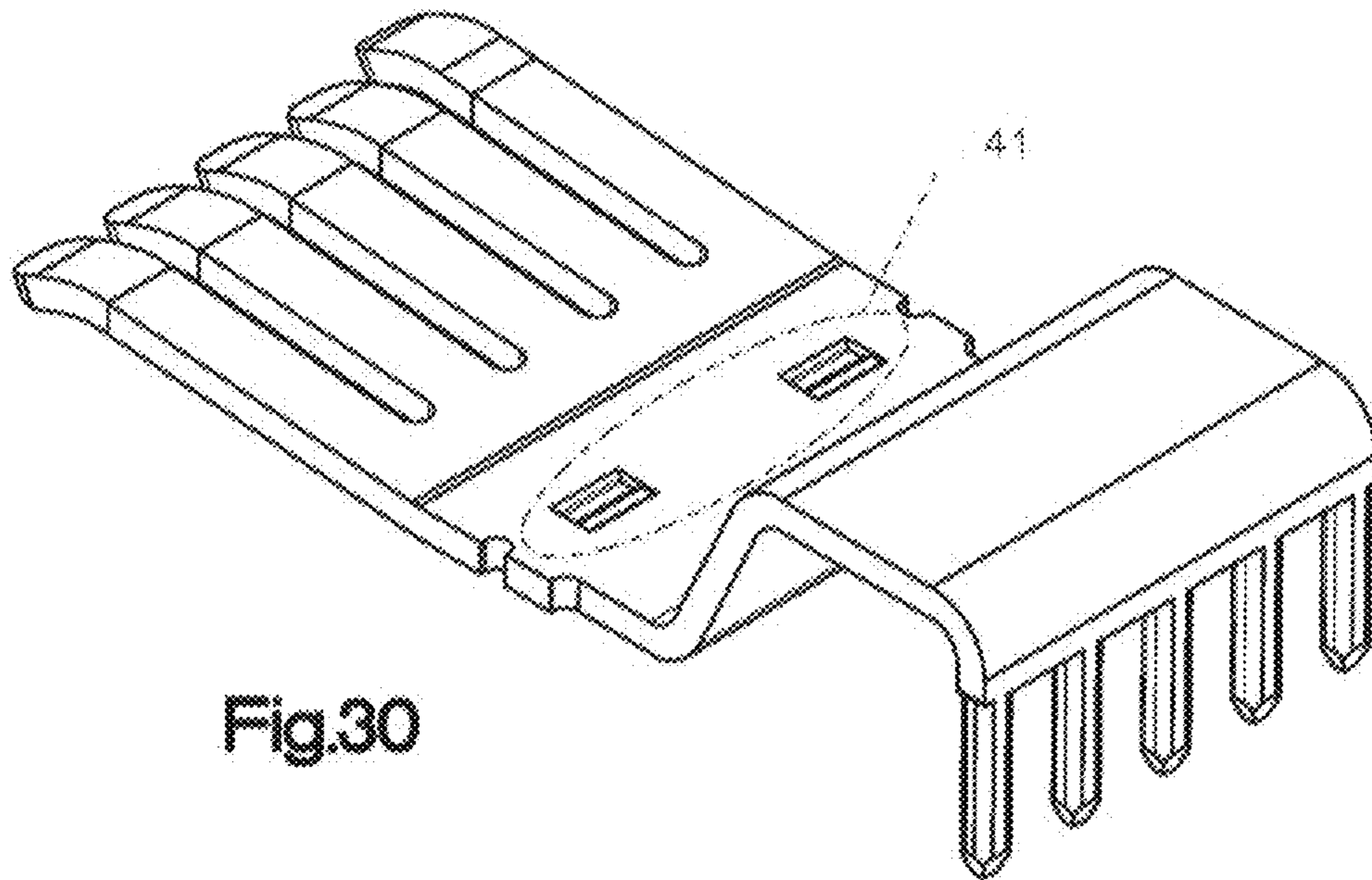

Fig.30

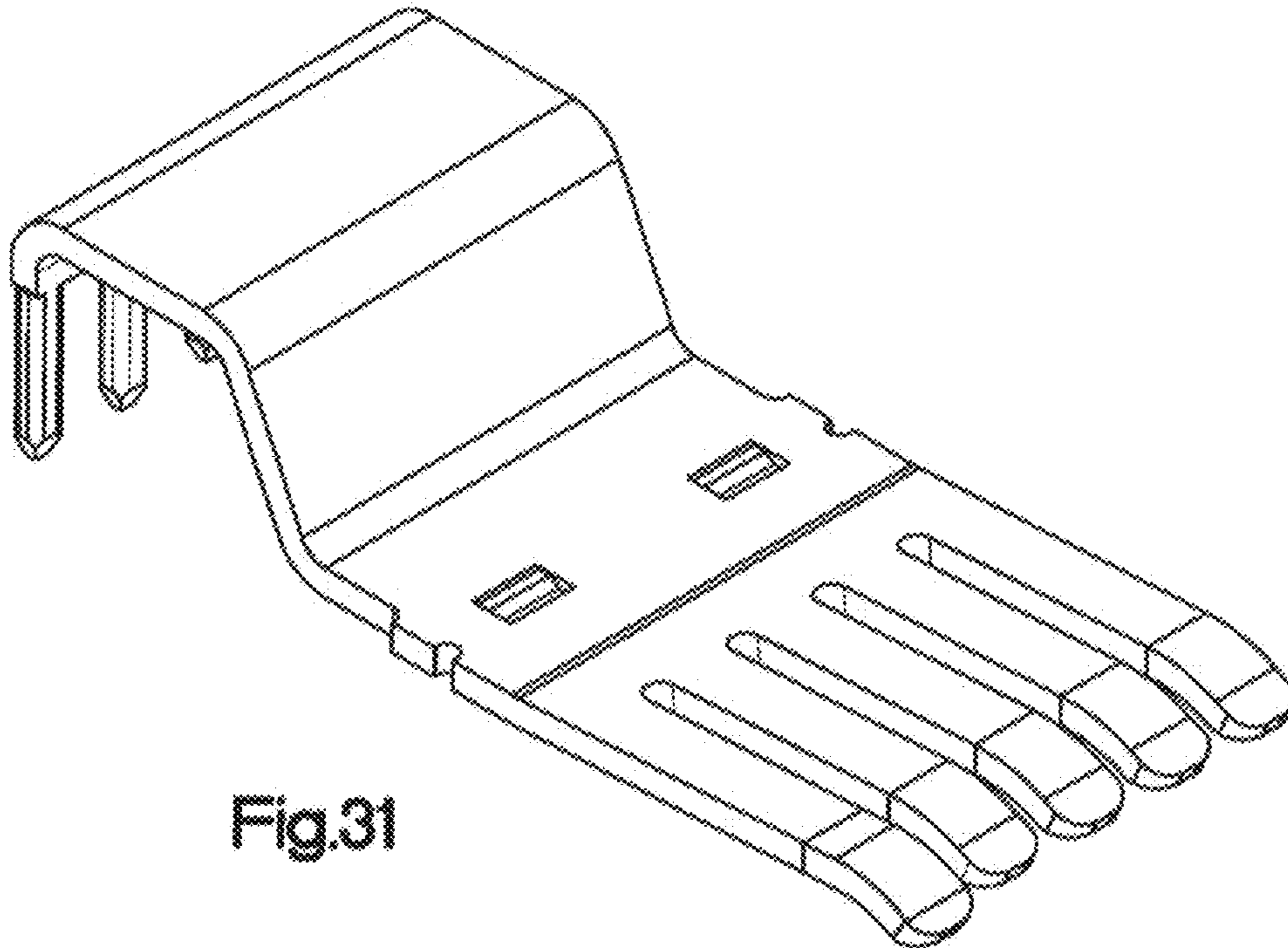

Fig.31

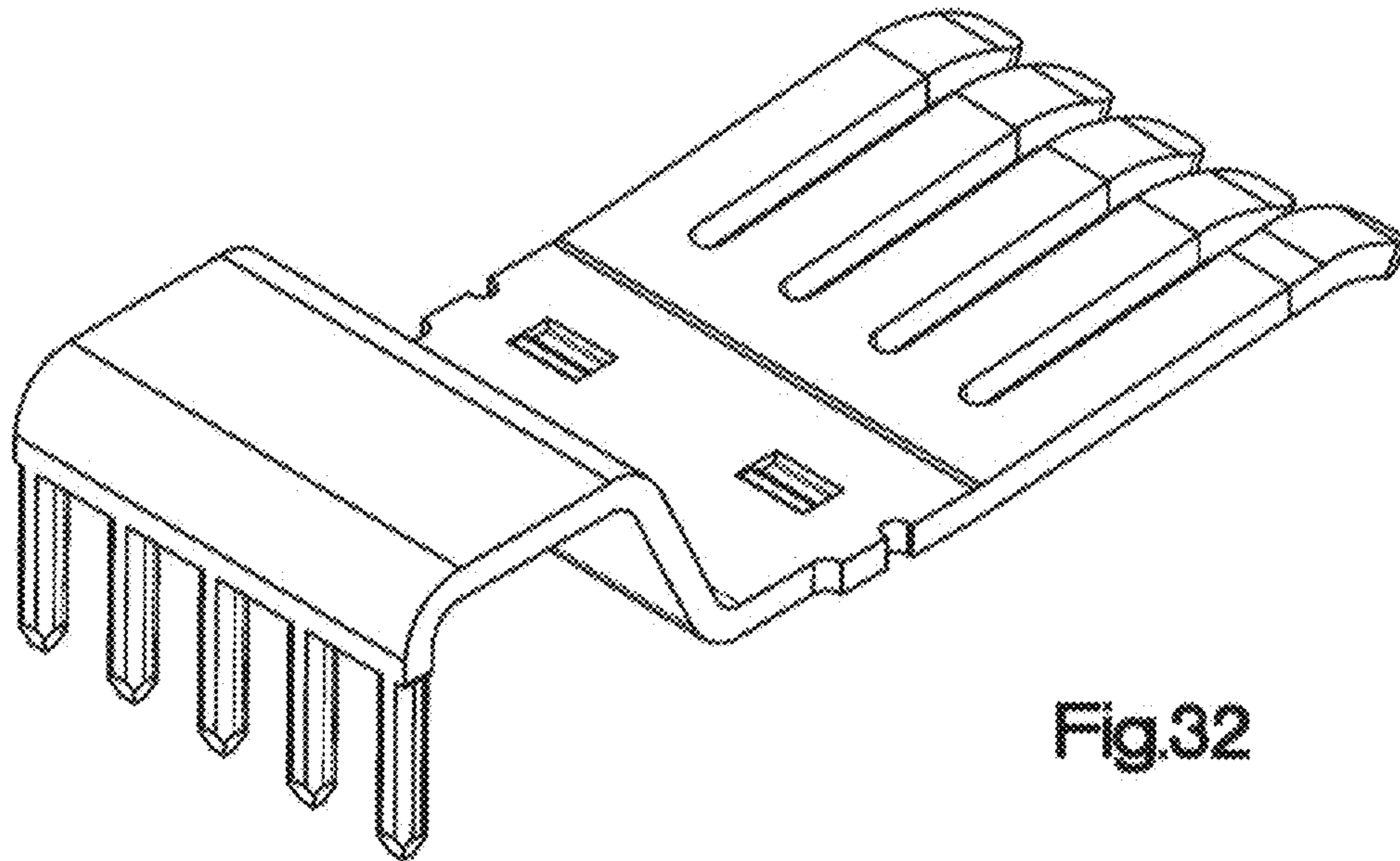
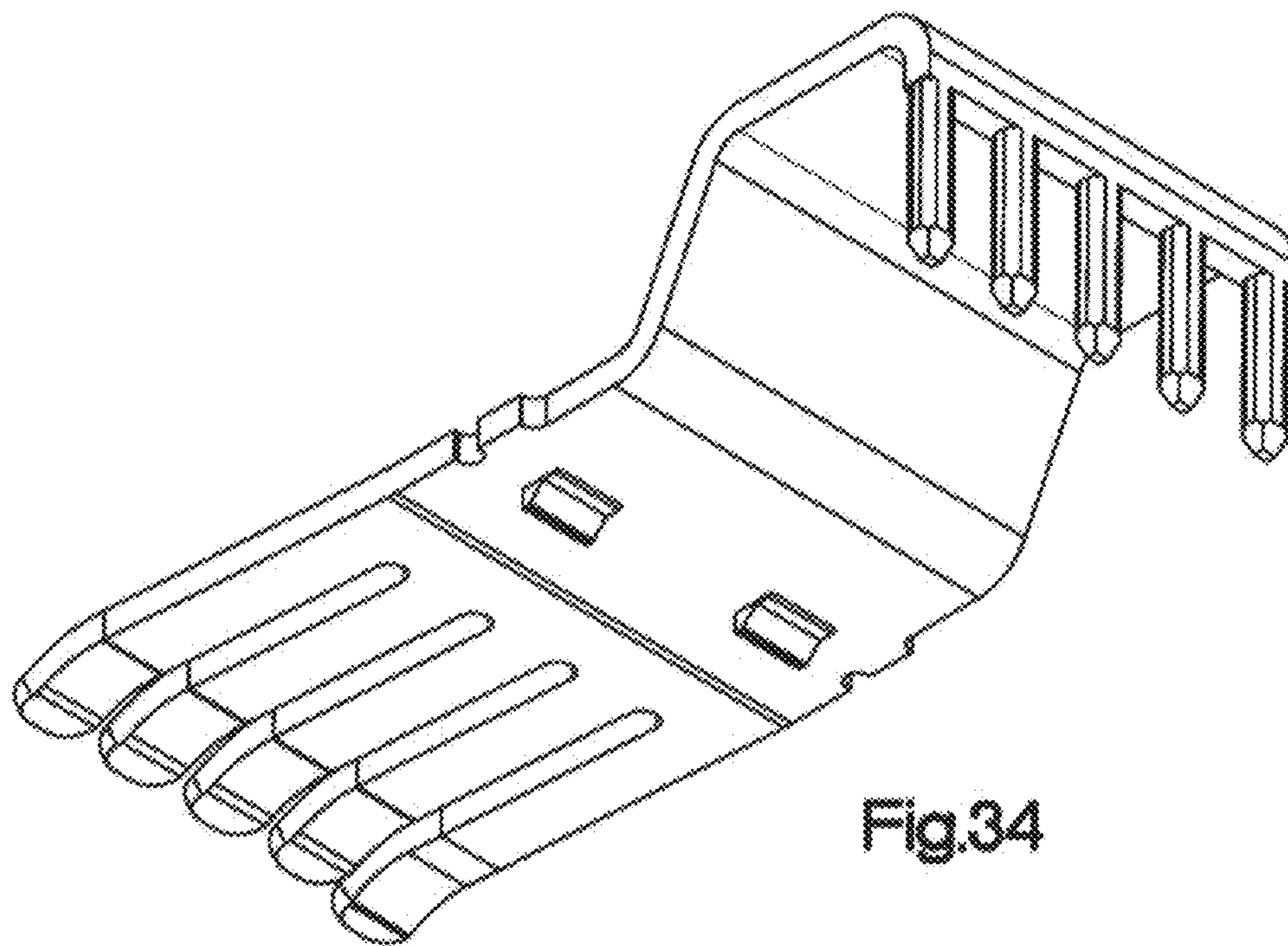
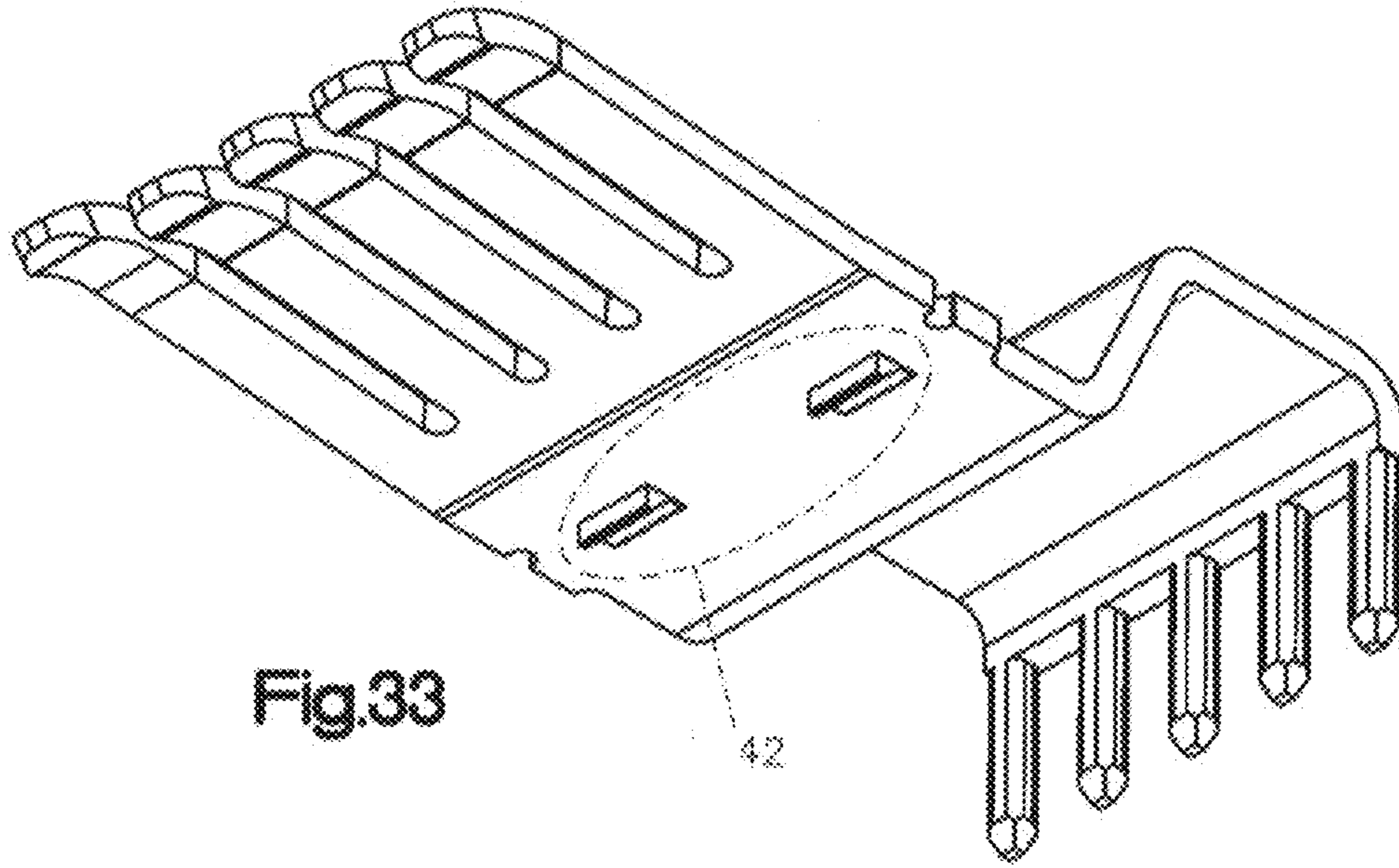

Fig.32



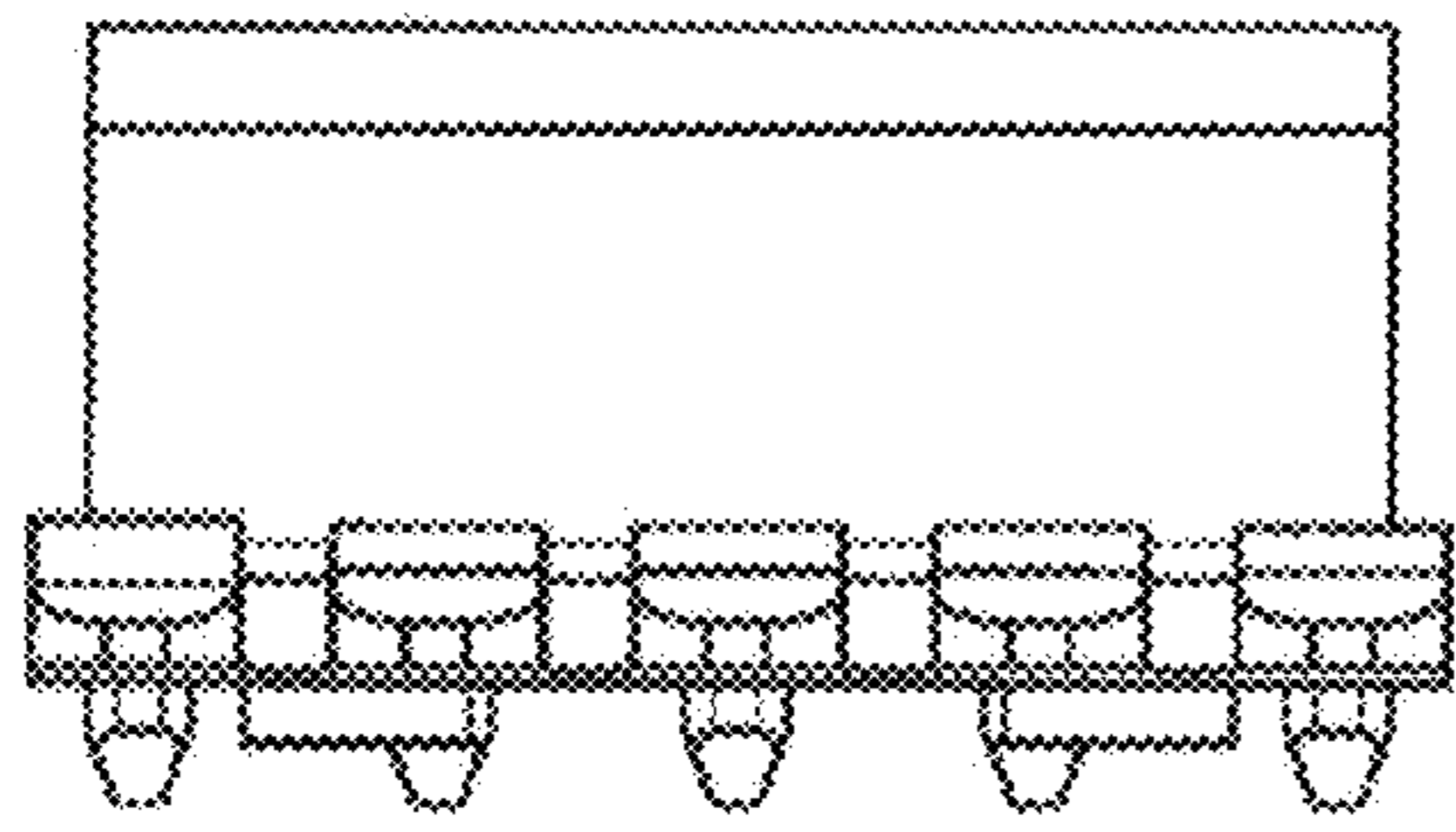

Fig.35

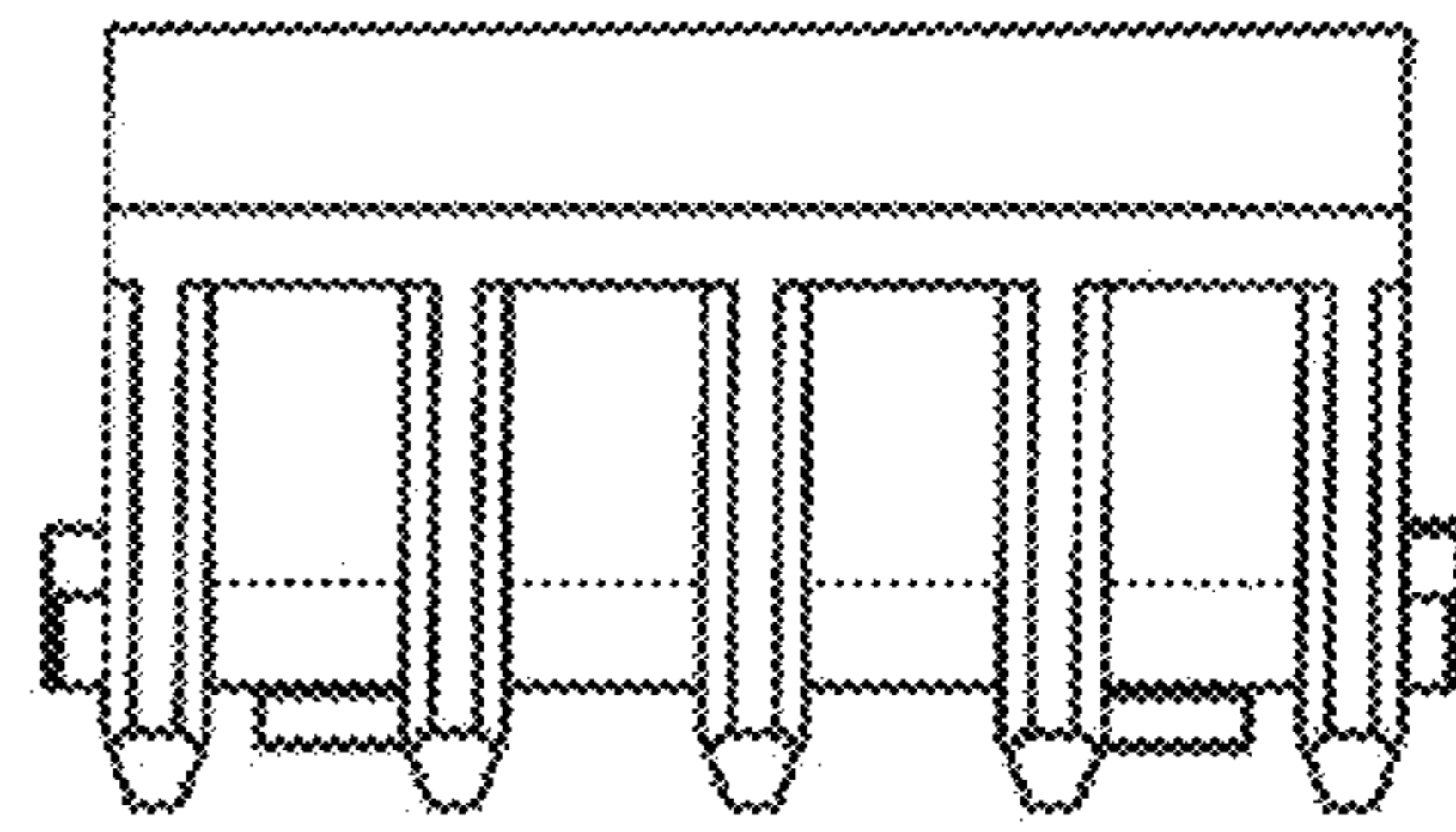

Fig.36

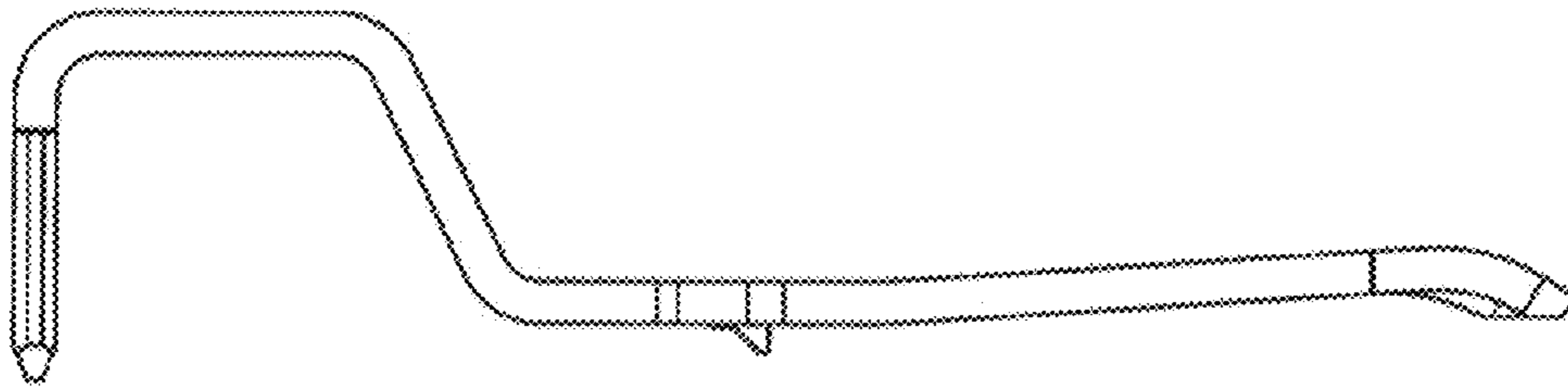

Fig.37

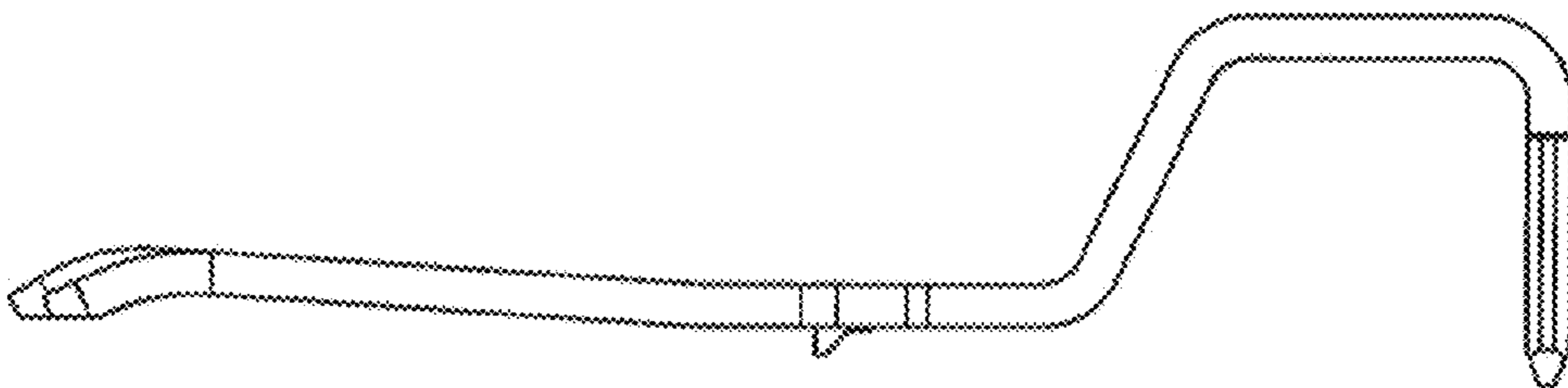

Fig.38

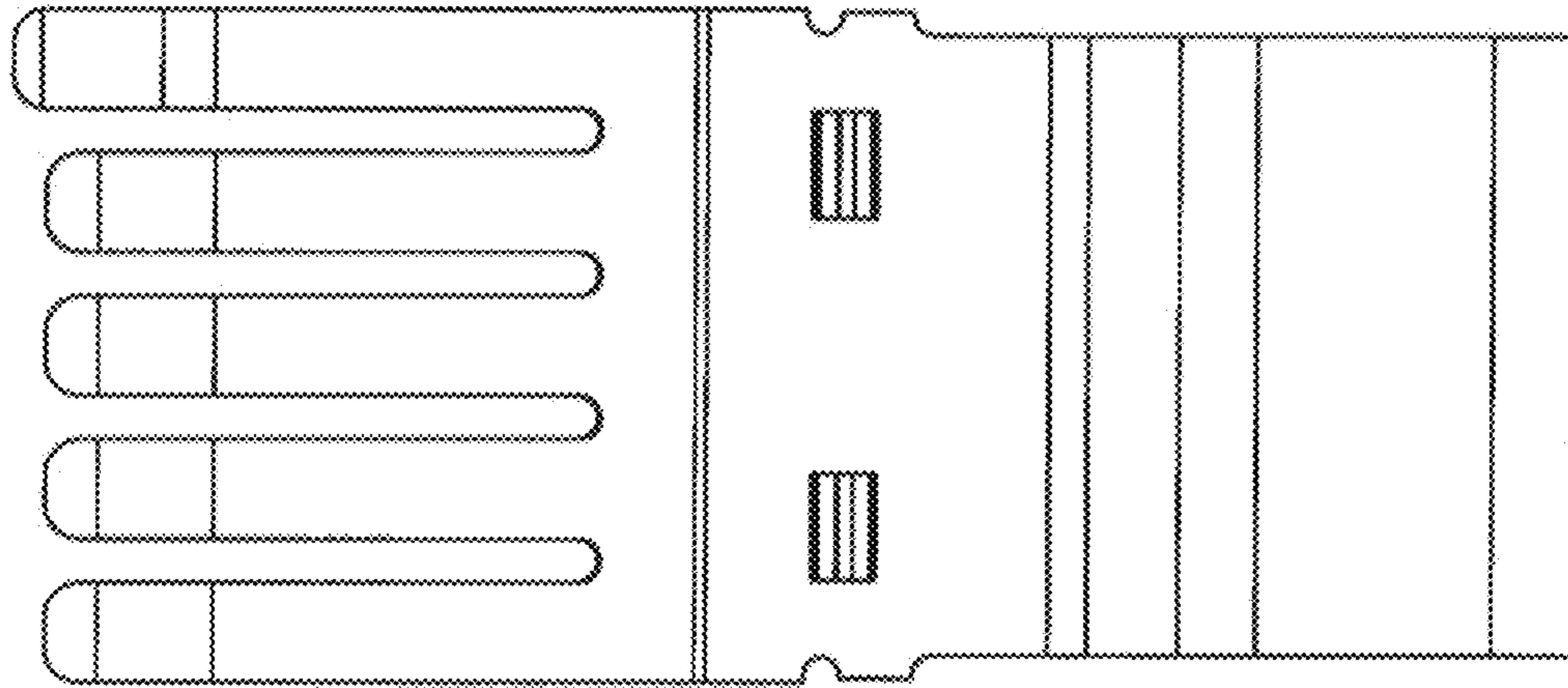

Fig.39

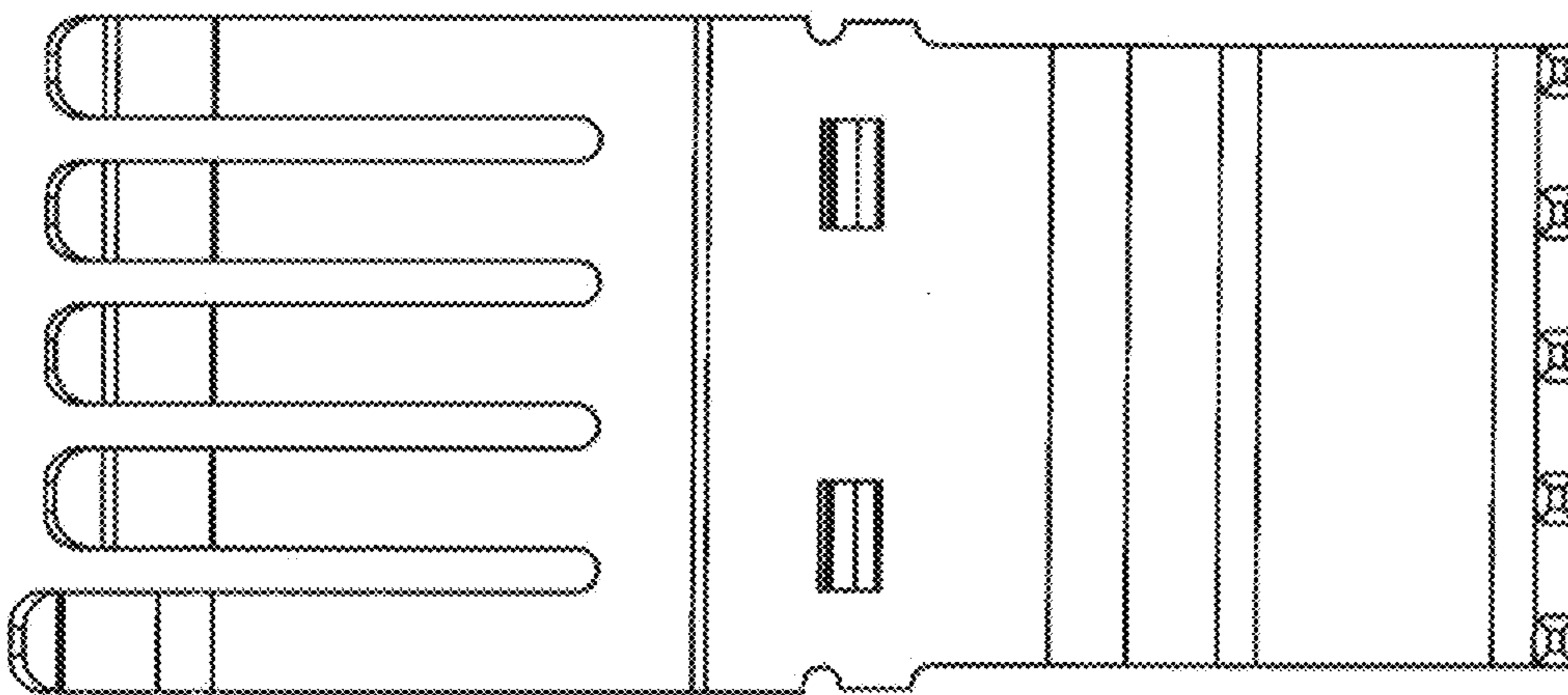

Fig.40

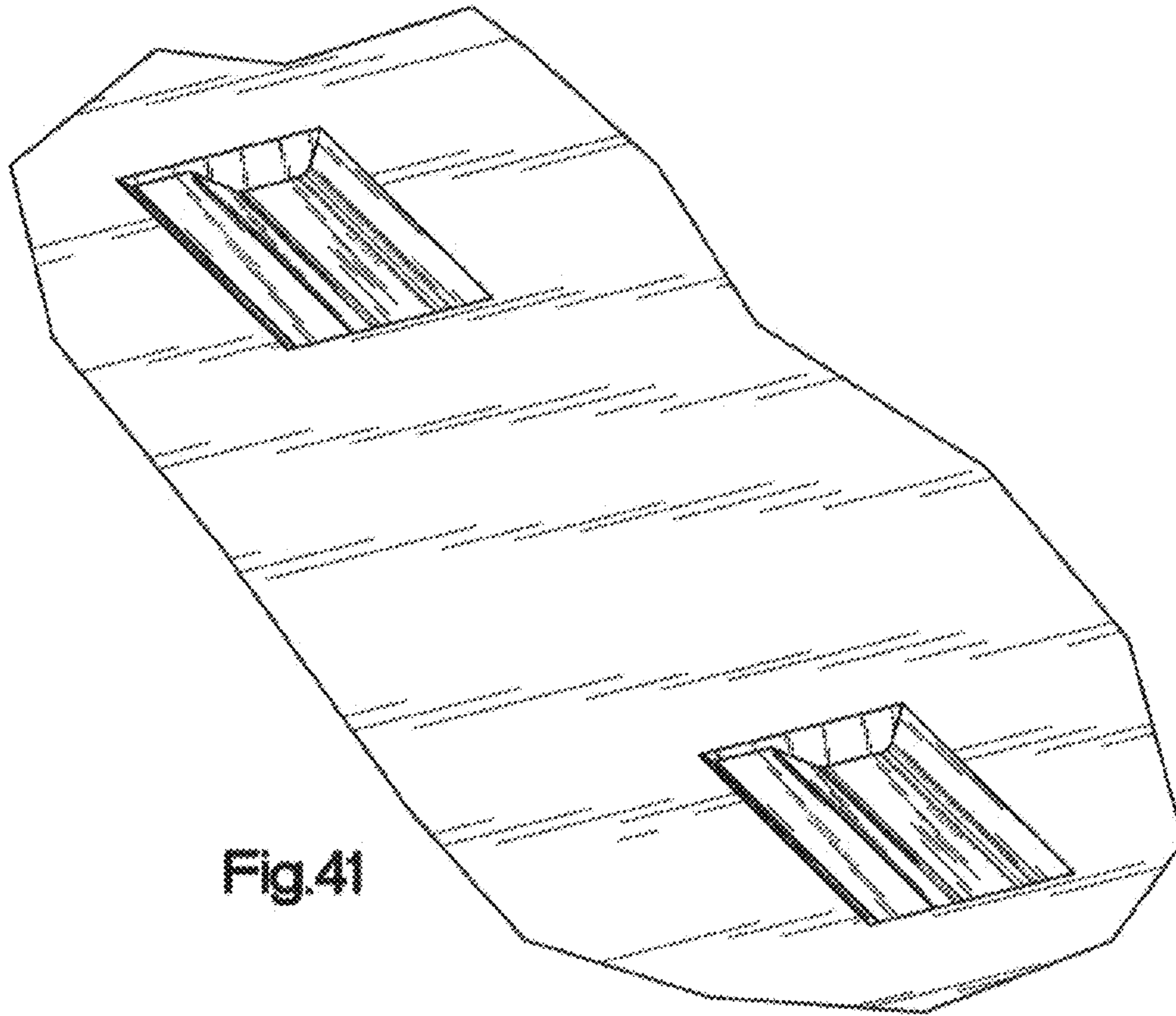

Fig.41

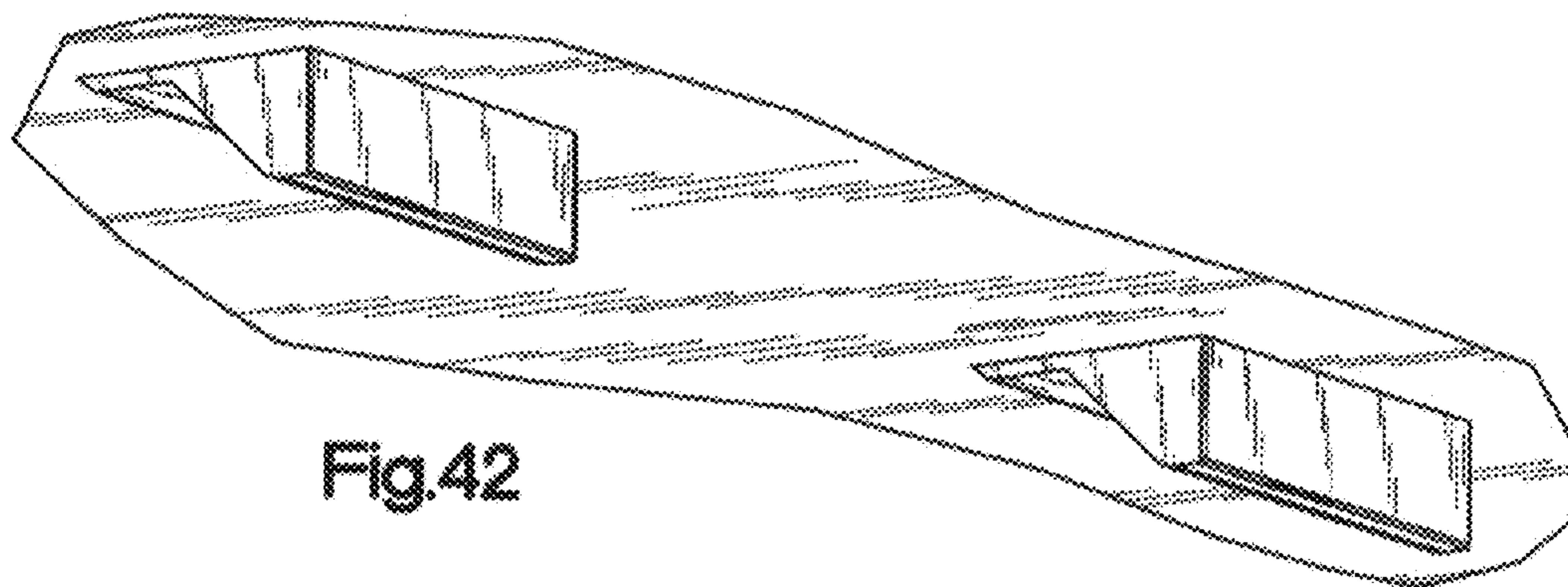

Fig.42

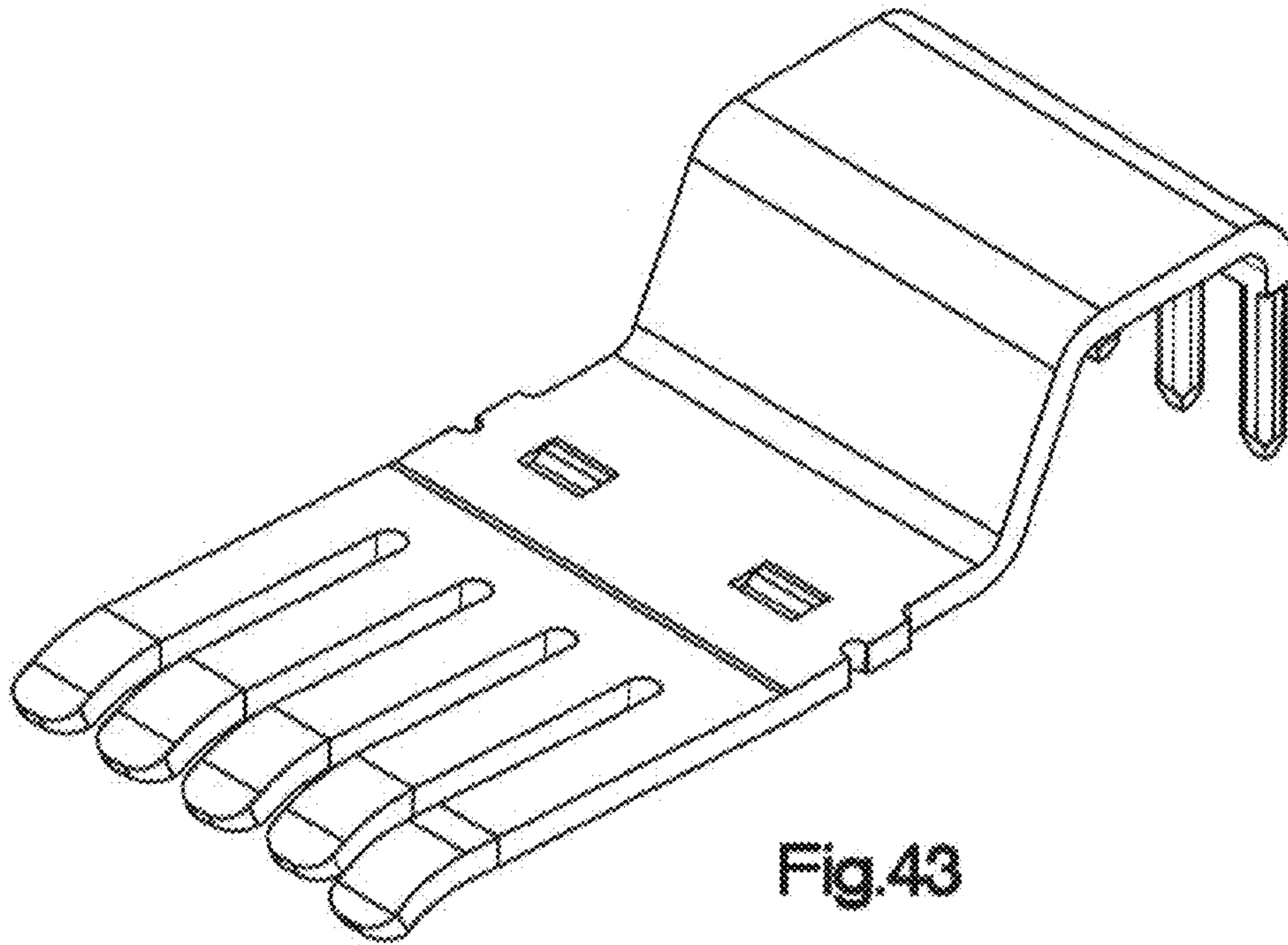

Fig.43

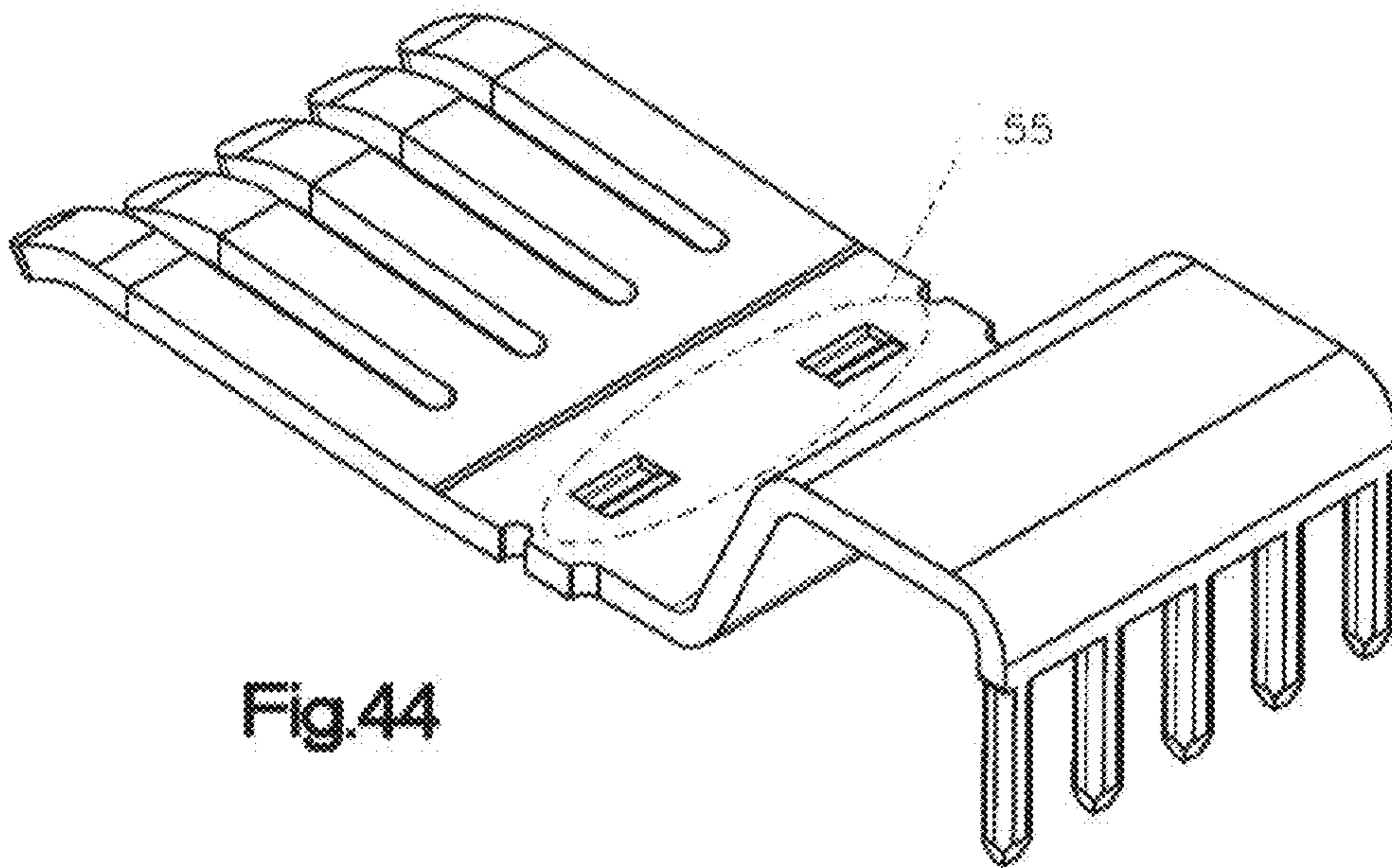

Fig.44

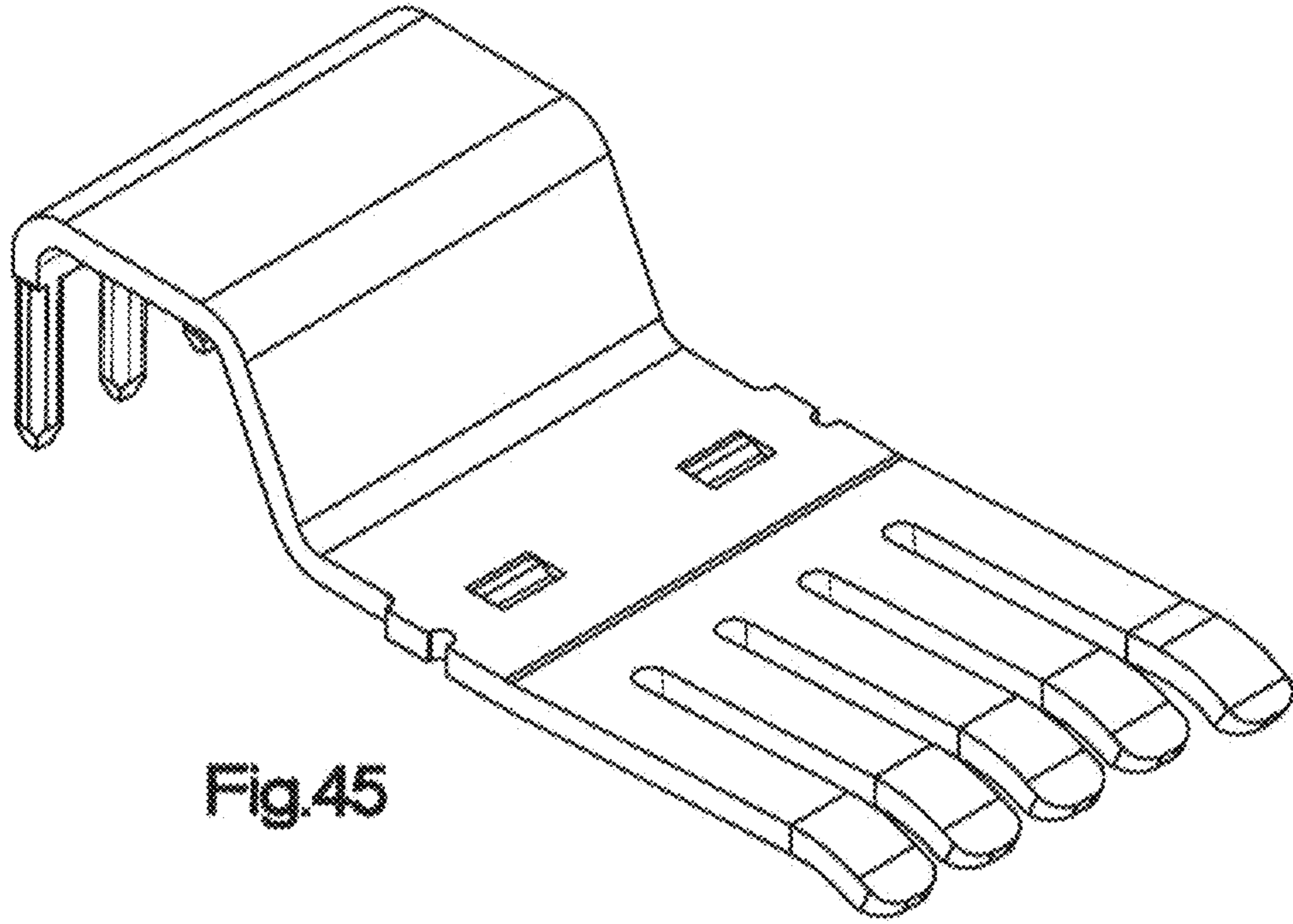

Fig.45

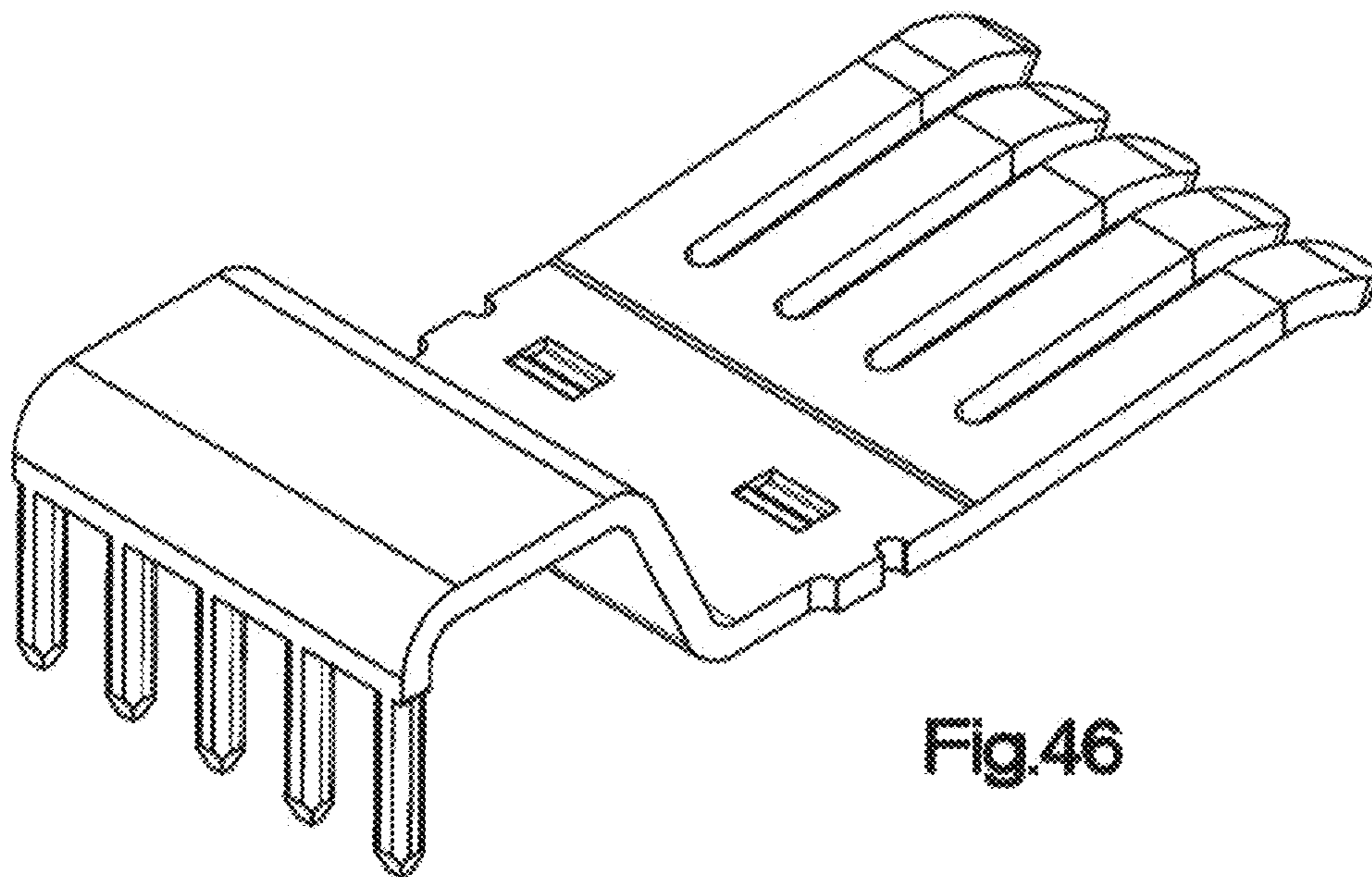
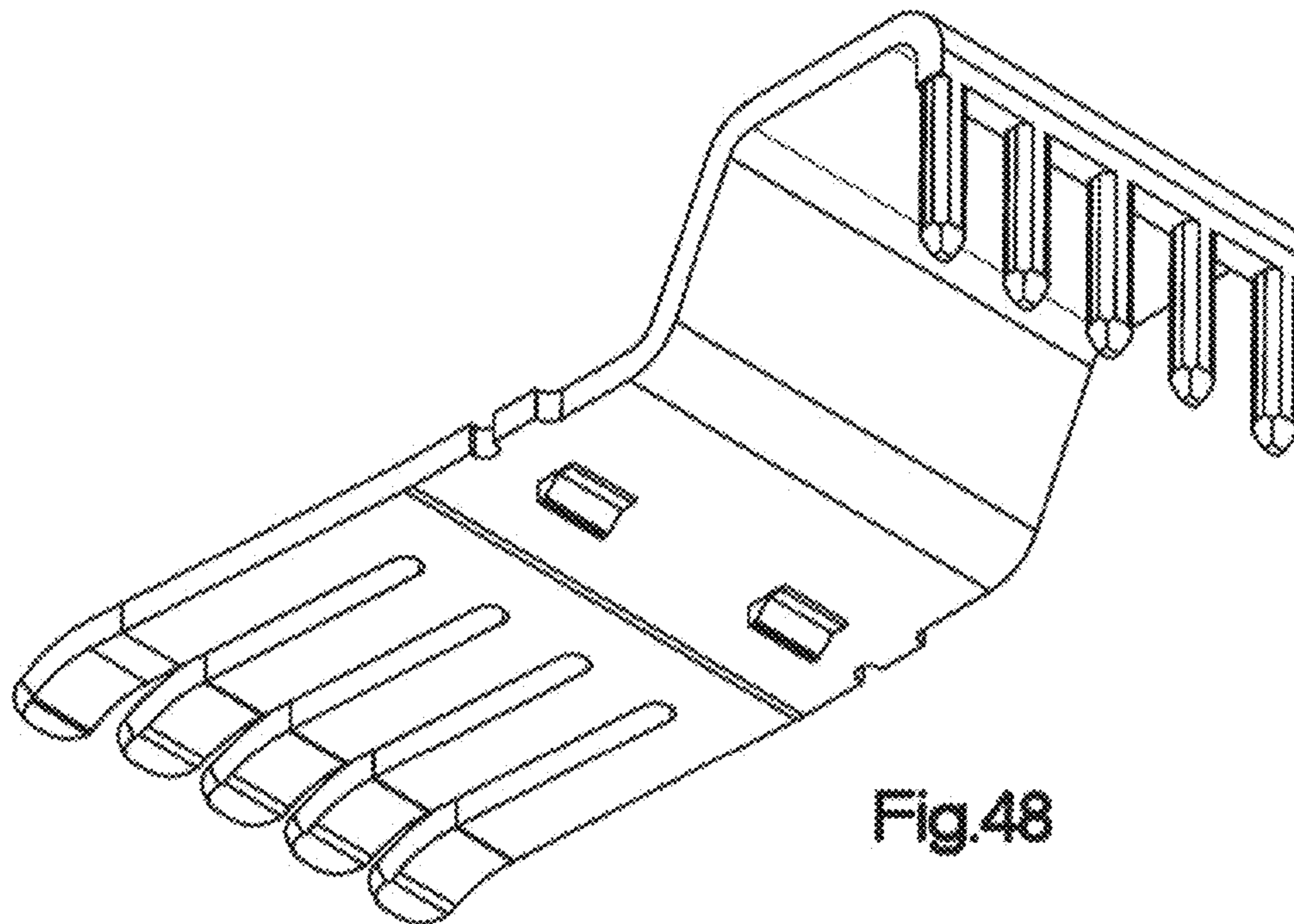
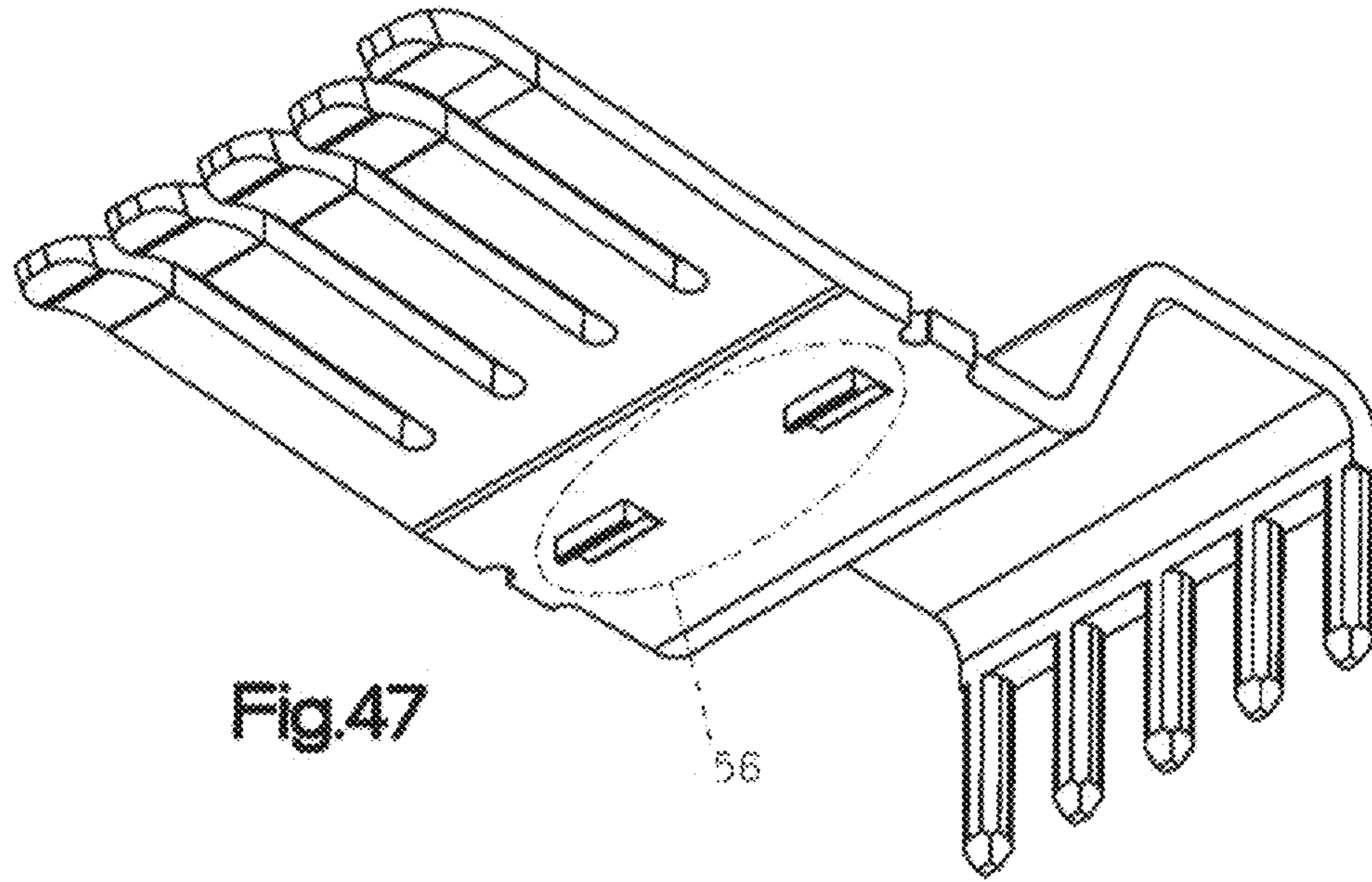

Fig.46



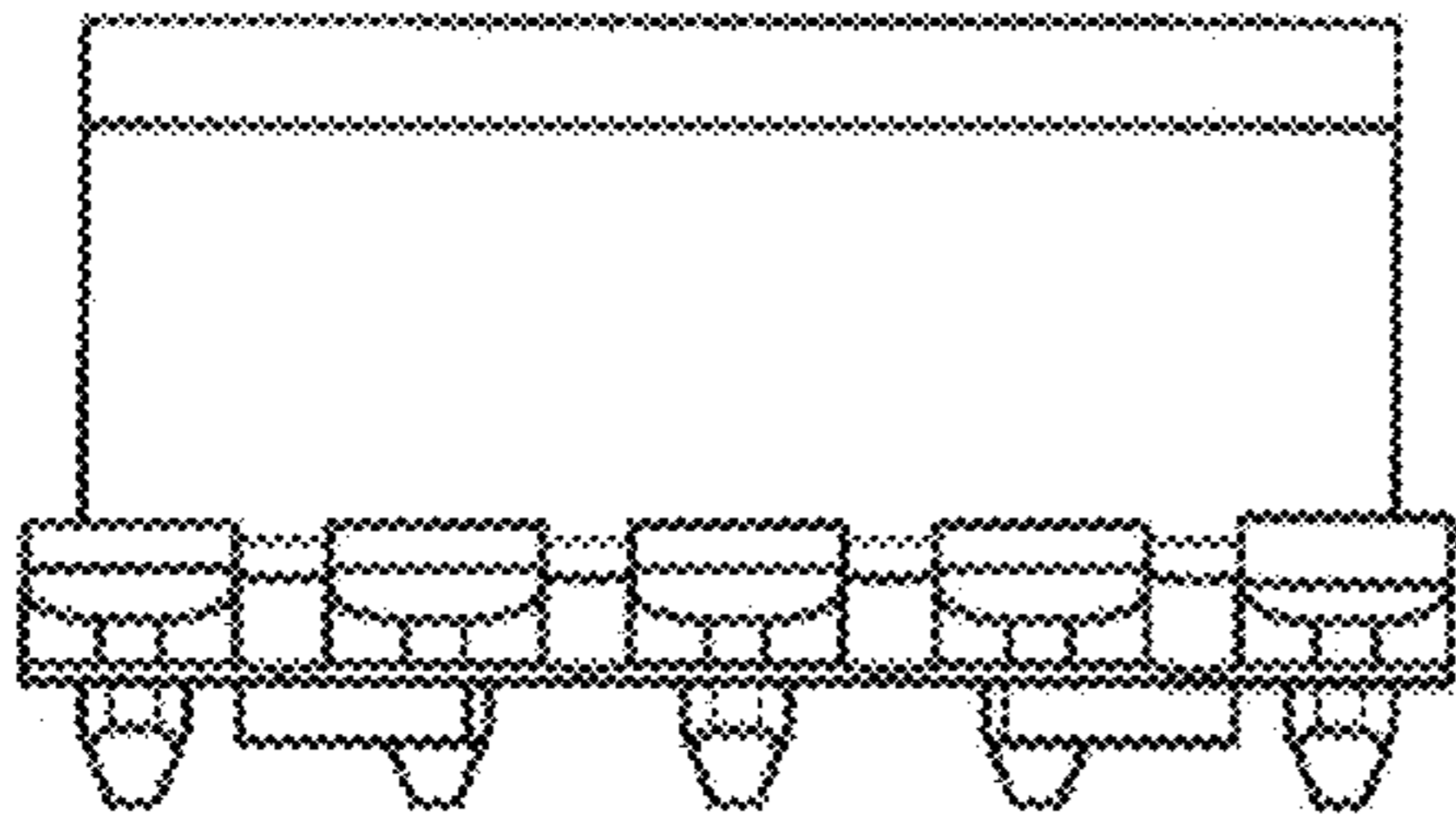

Fig.49

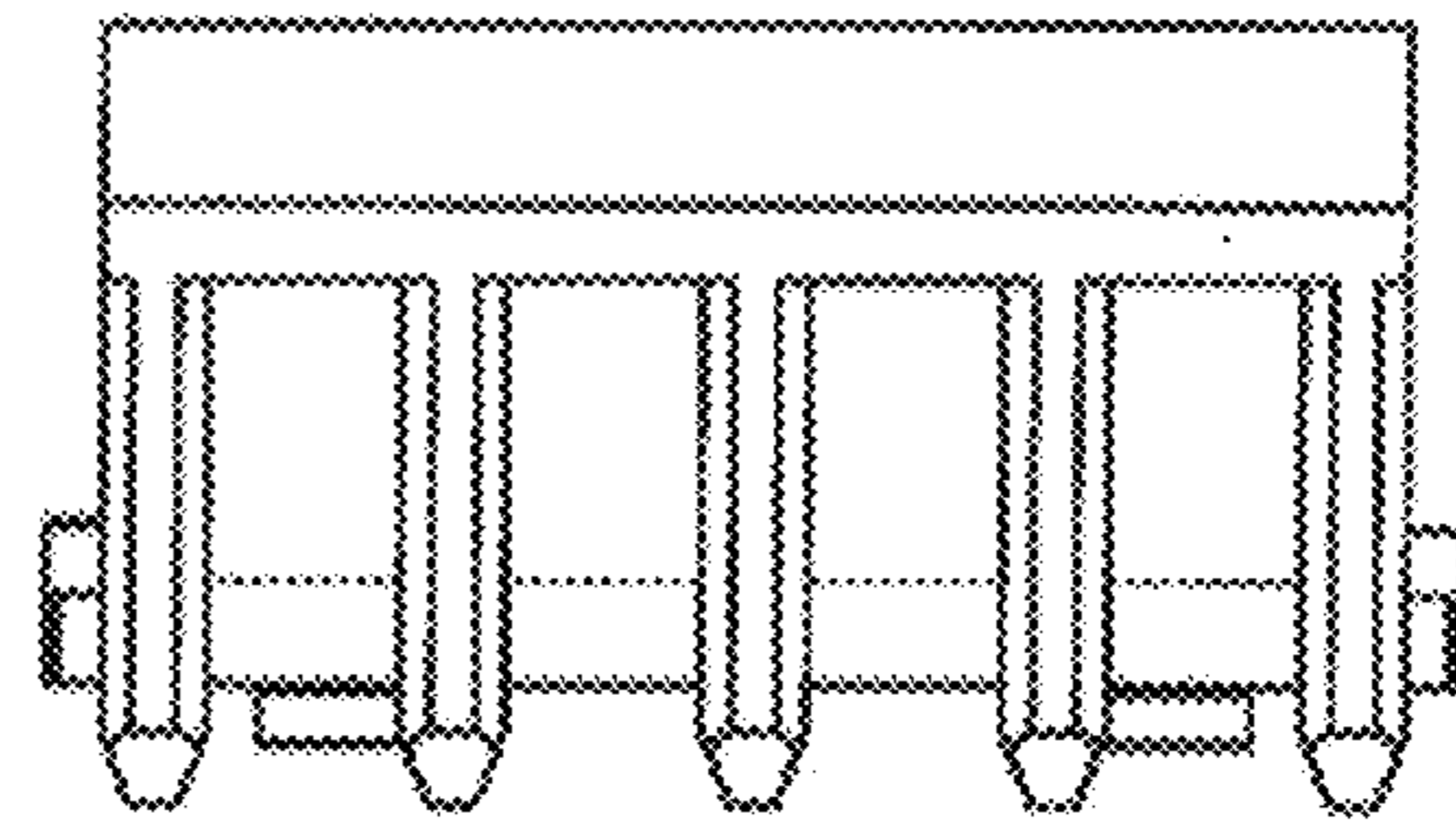

Fig.50

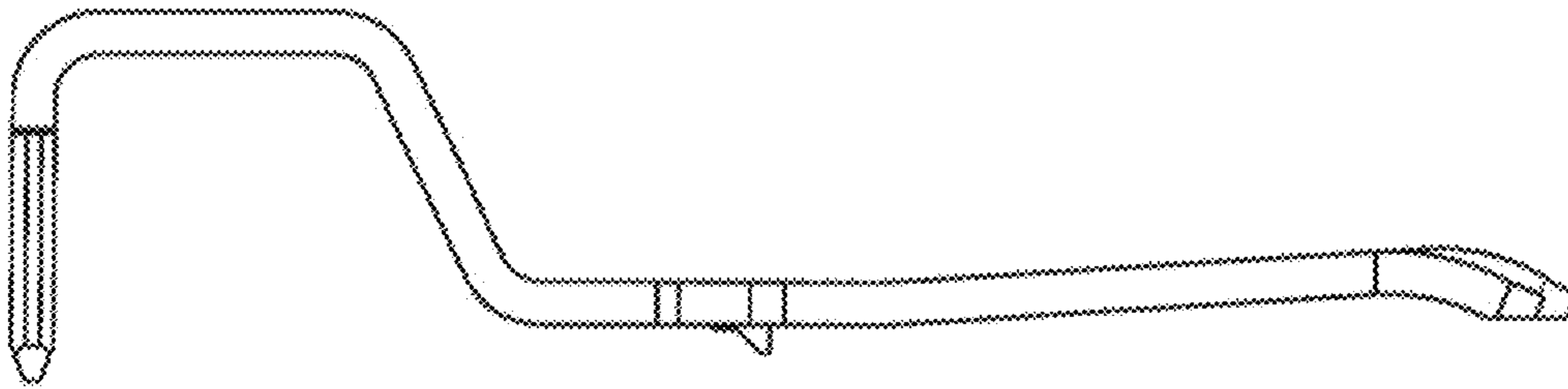

Fig.51

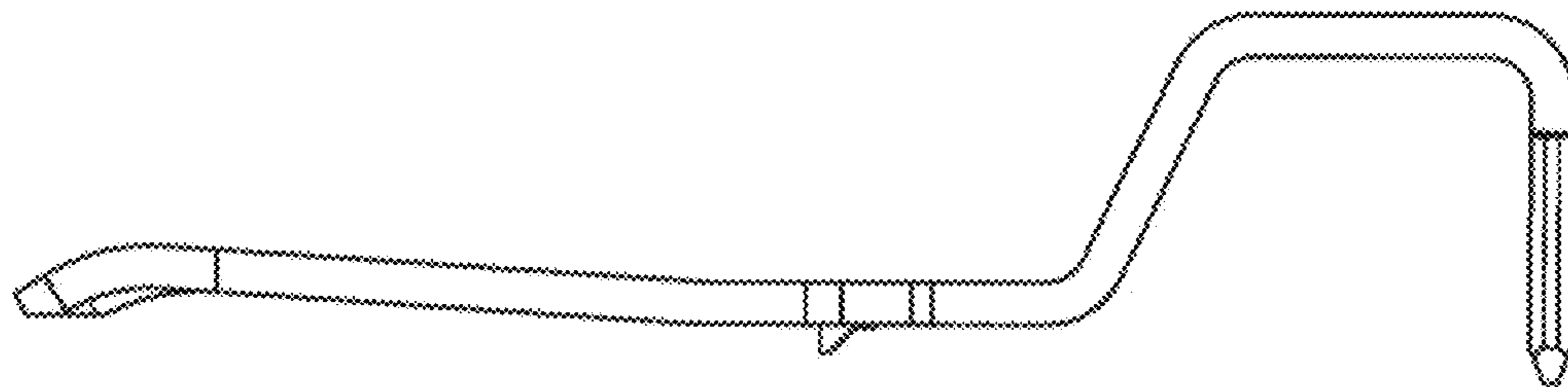

Fig.52

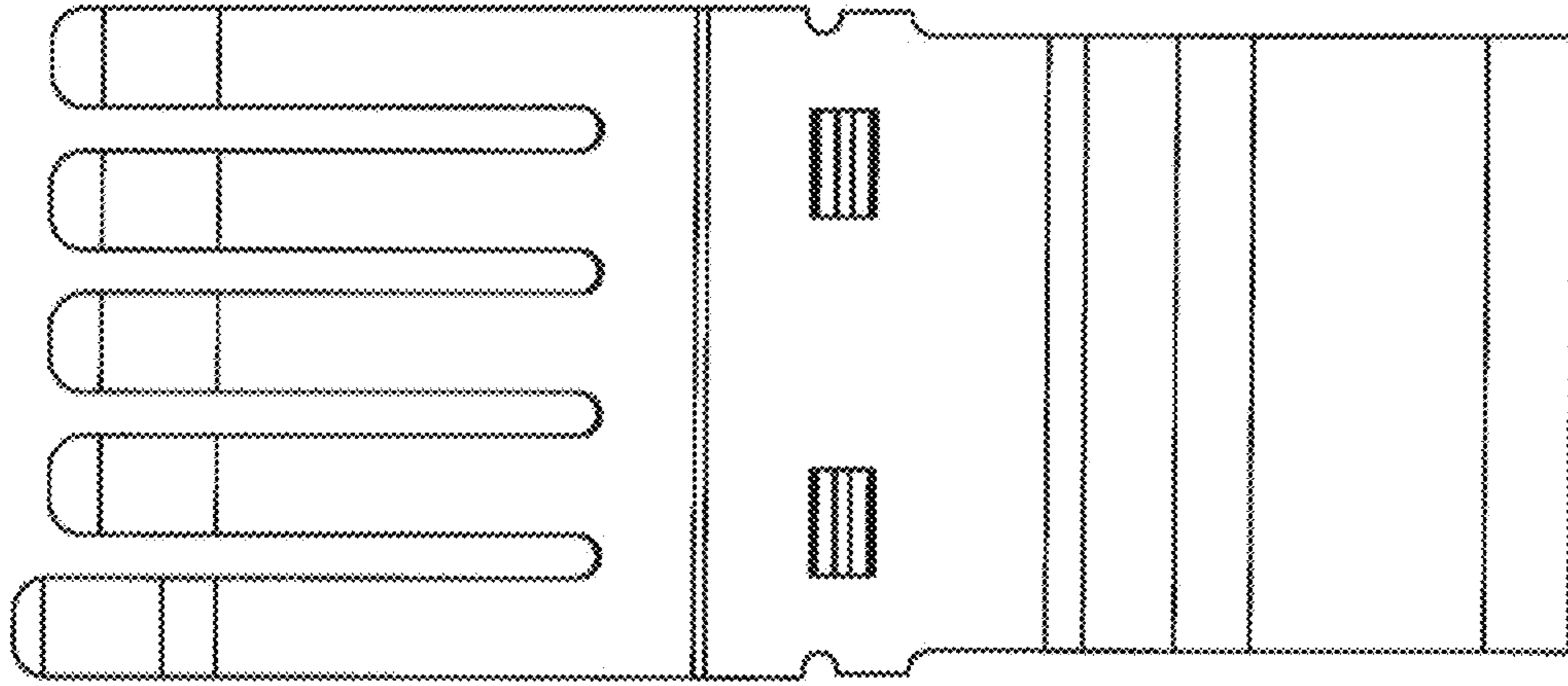

Fig.53

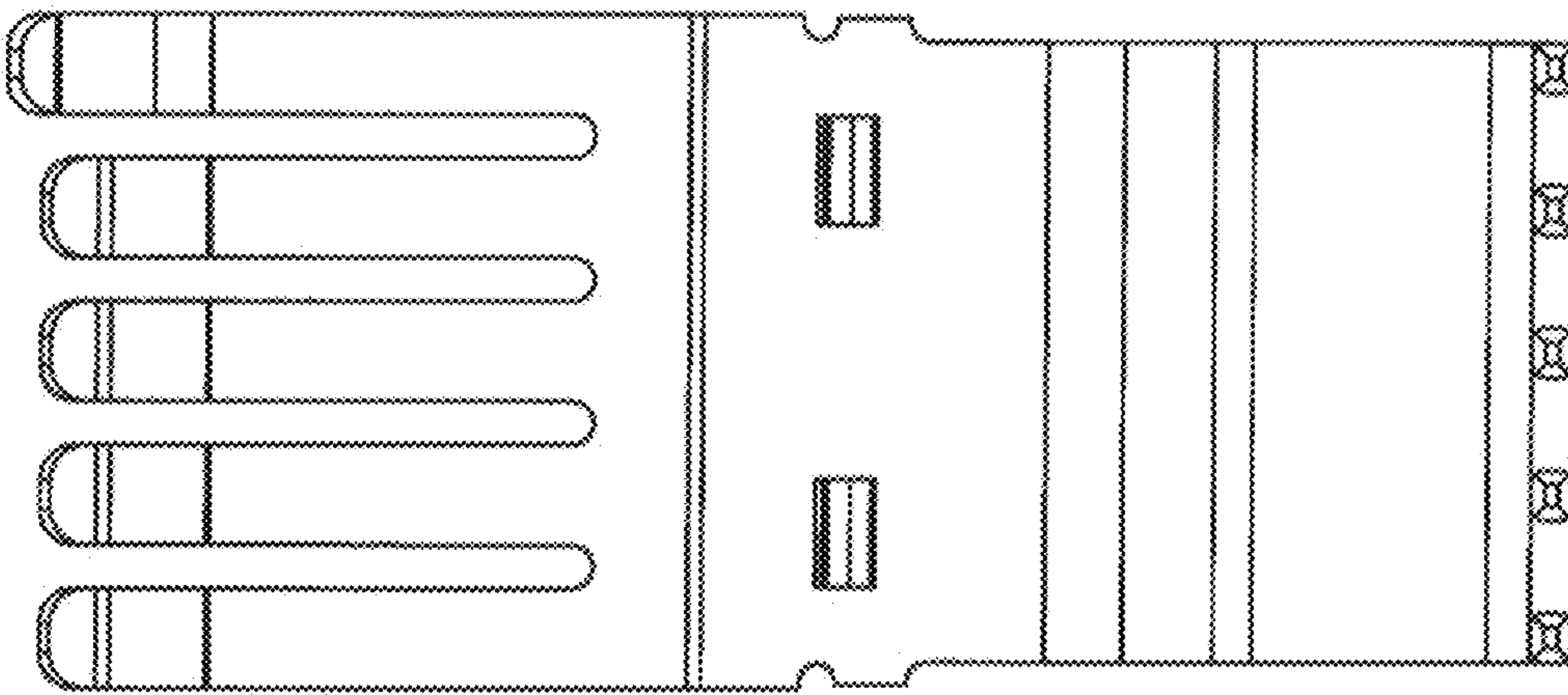

Fig.54

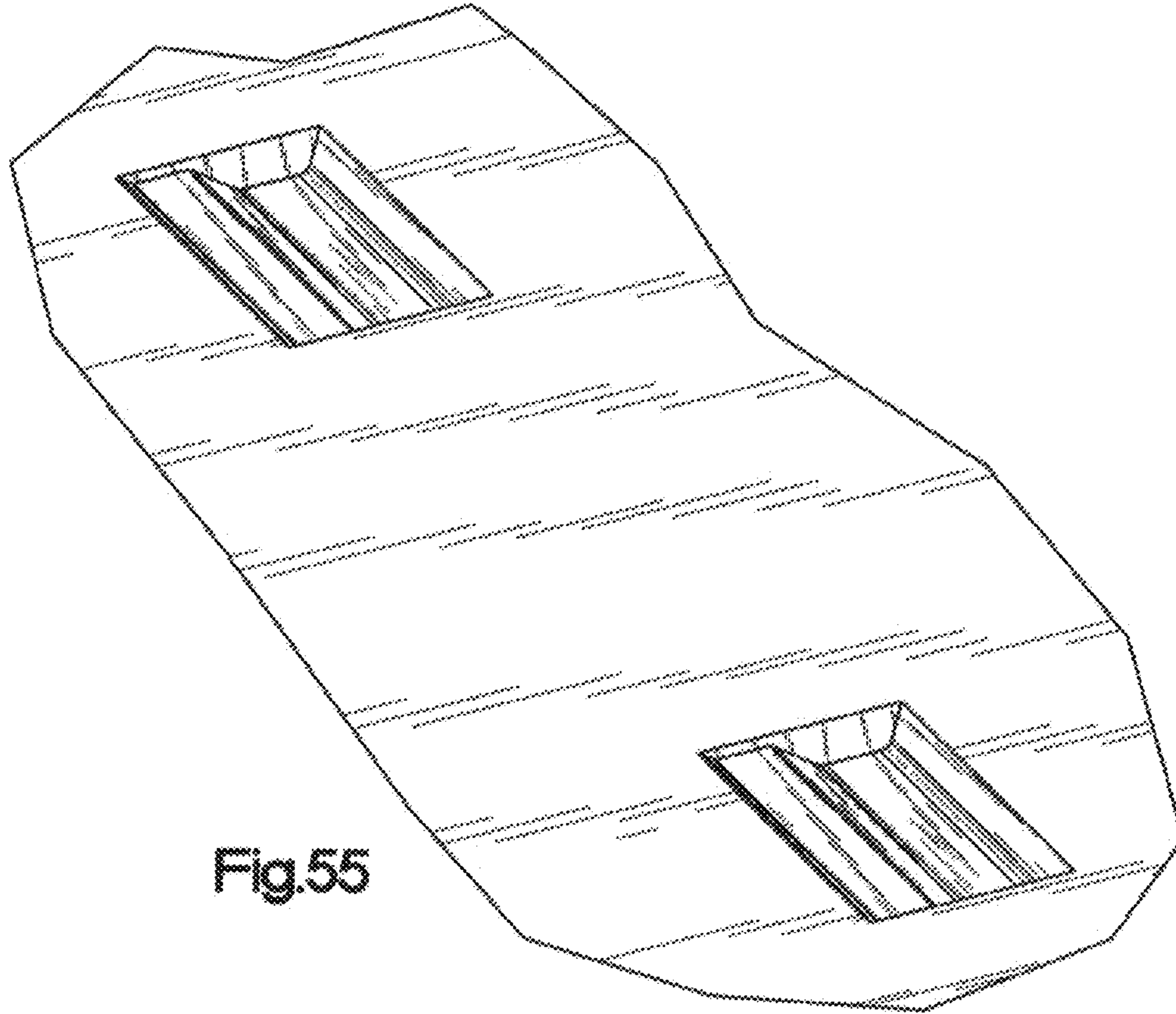

Fig.55

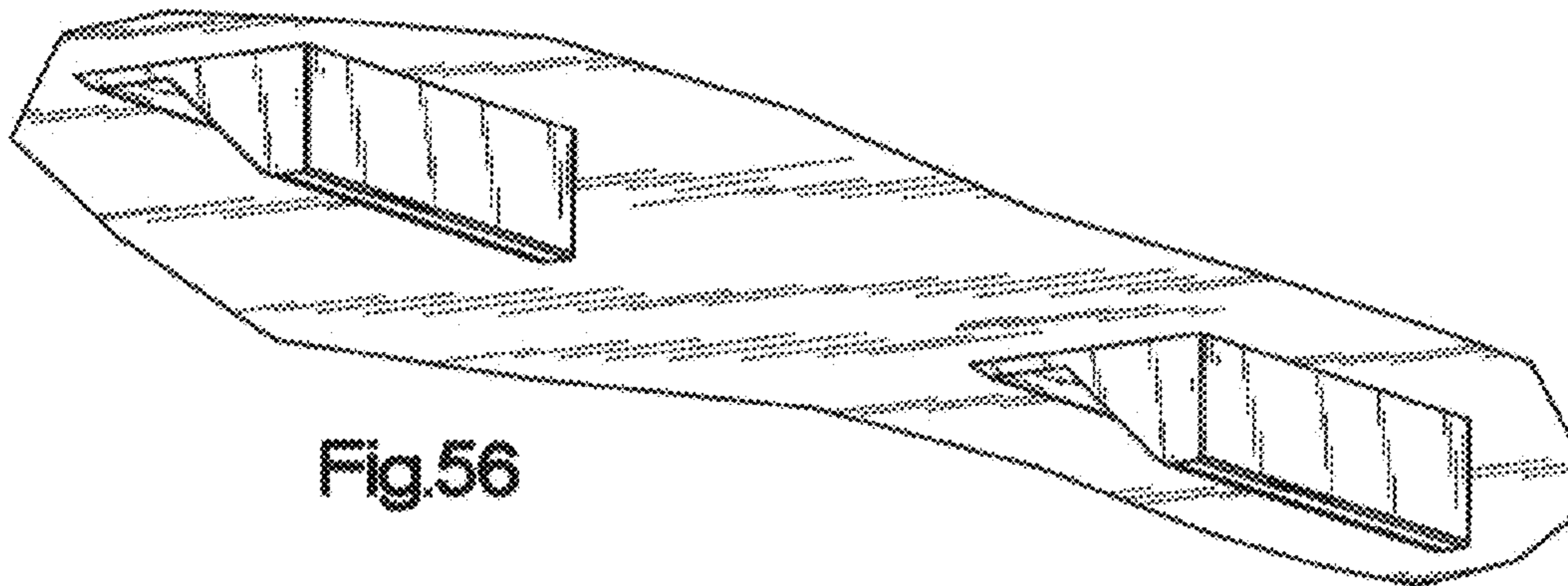

Fig.56

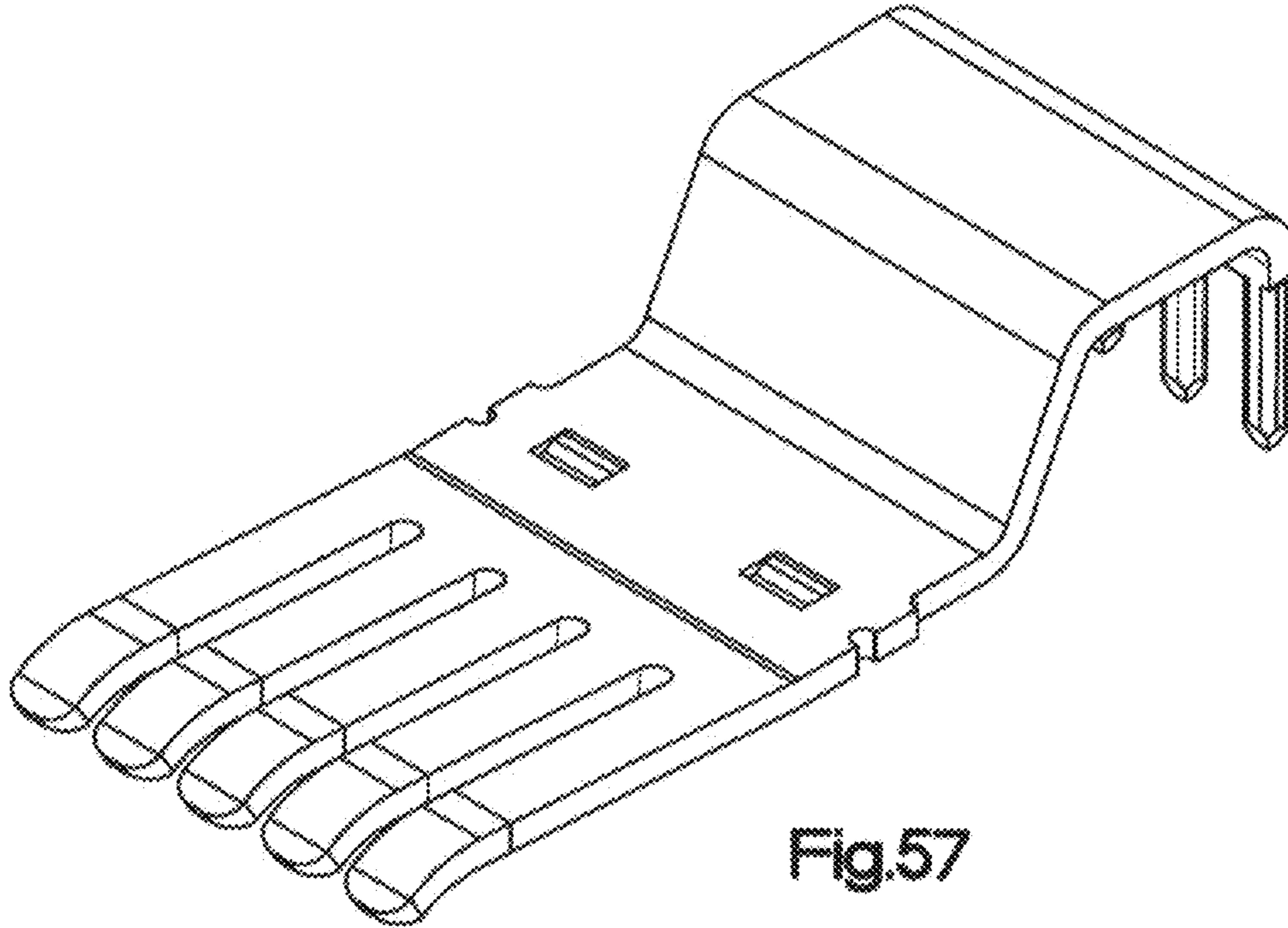

Fig. 57

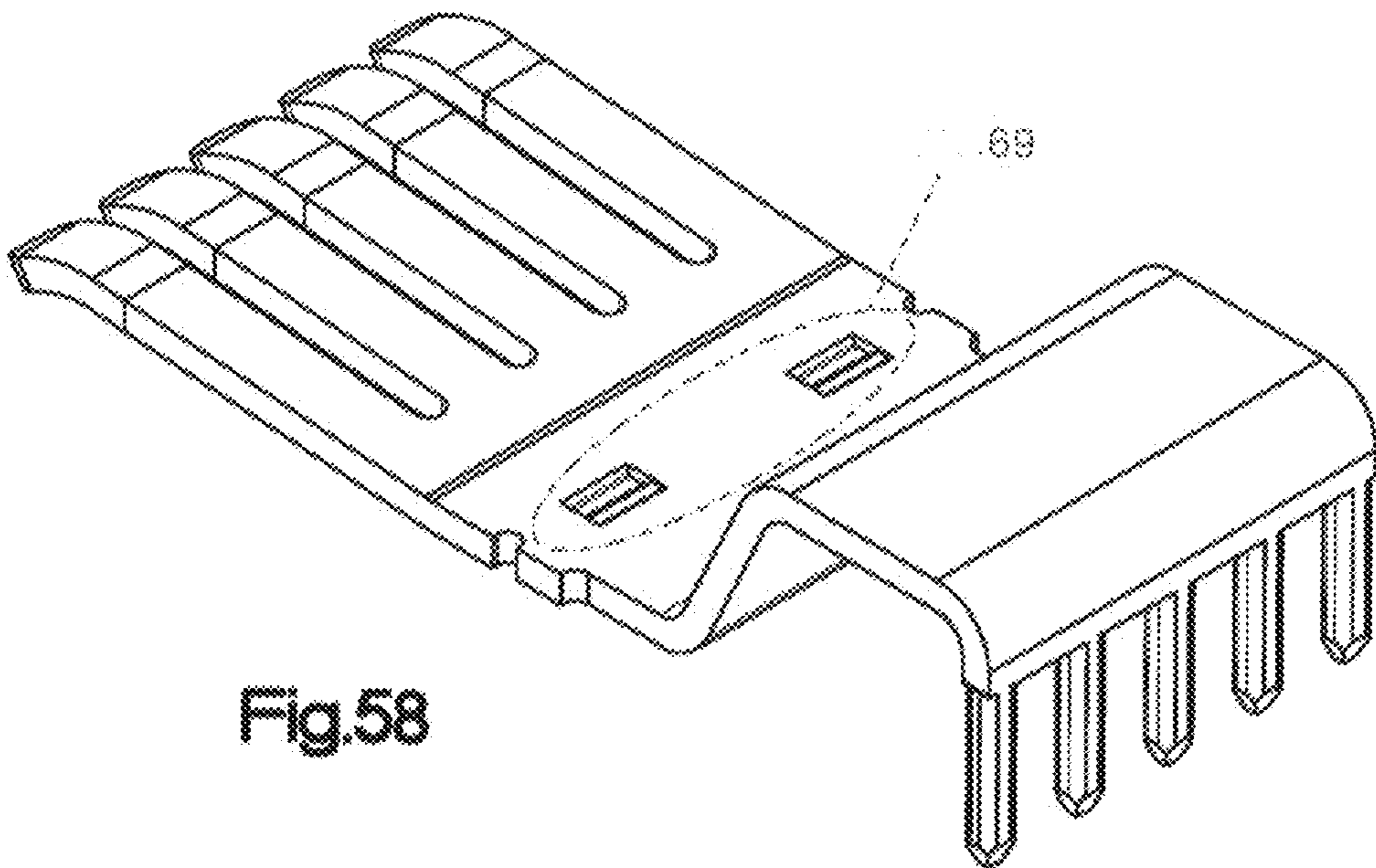

Fig. 58

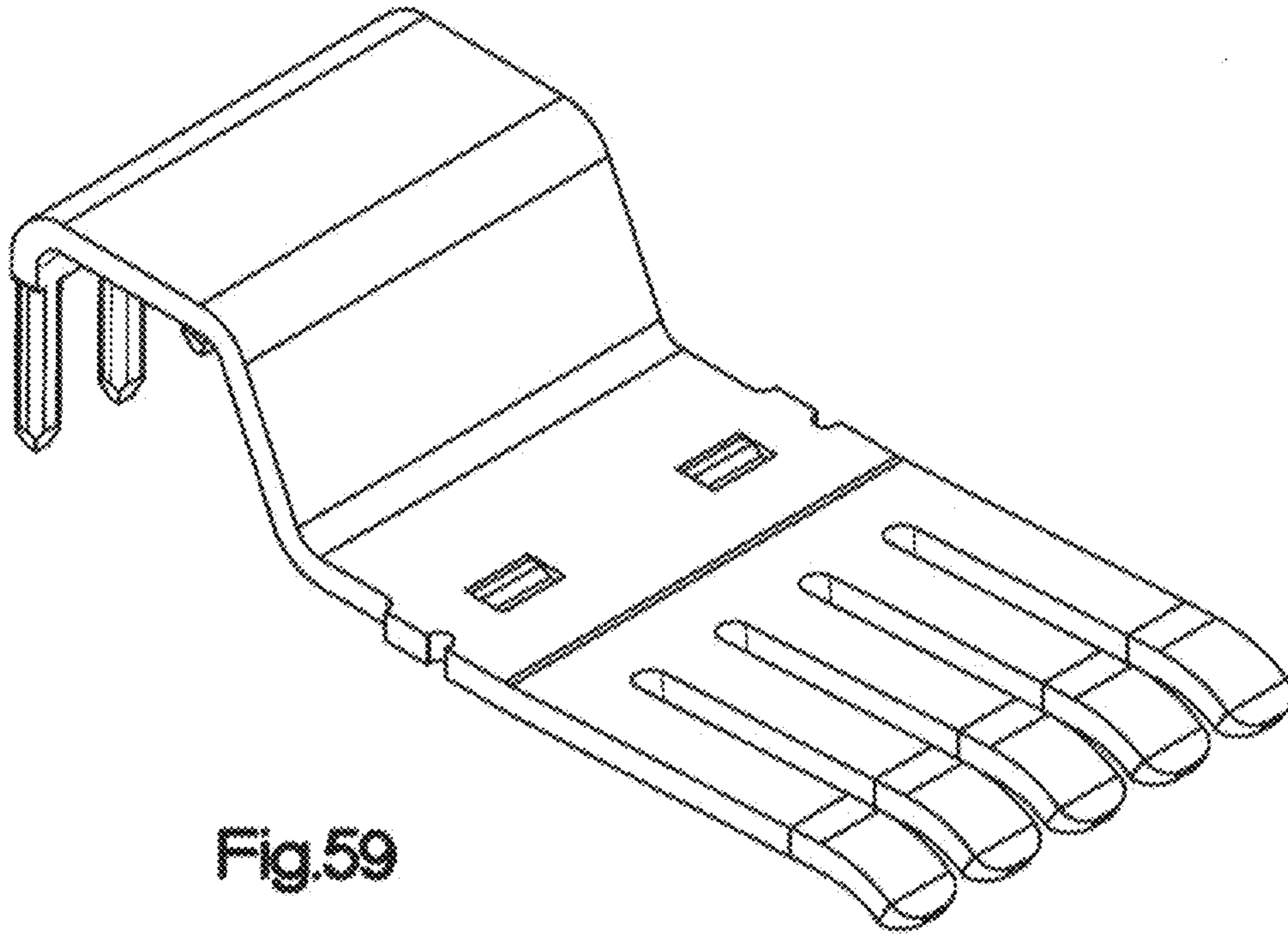

Fig.59

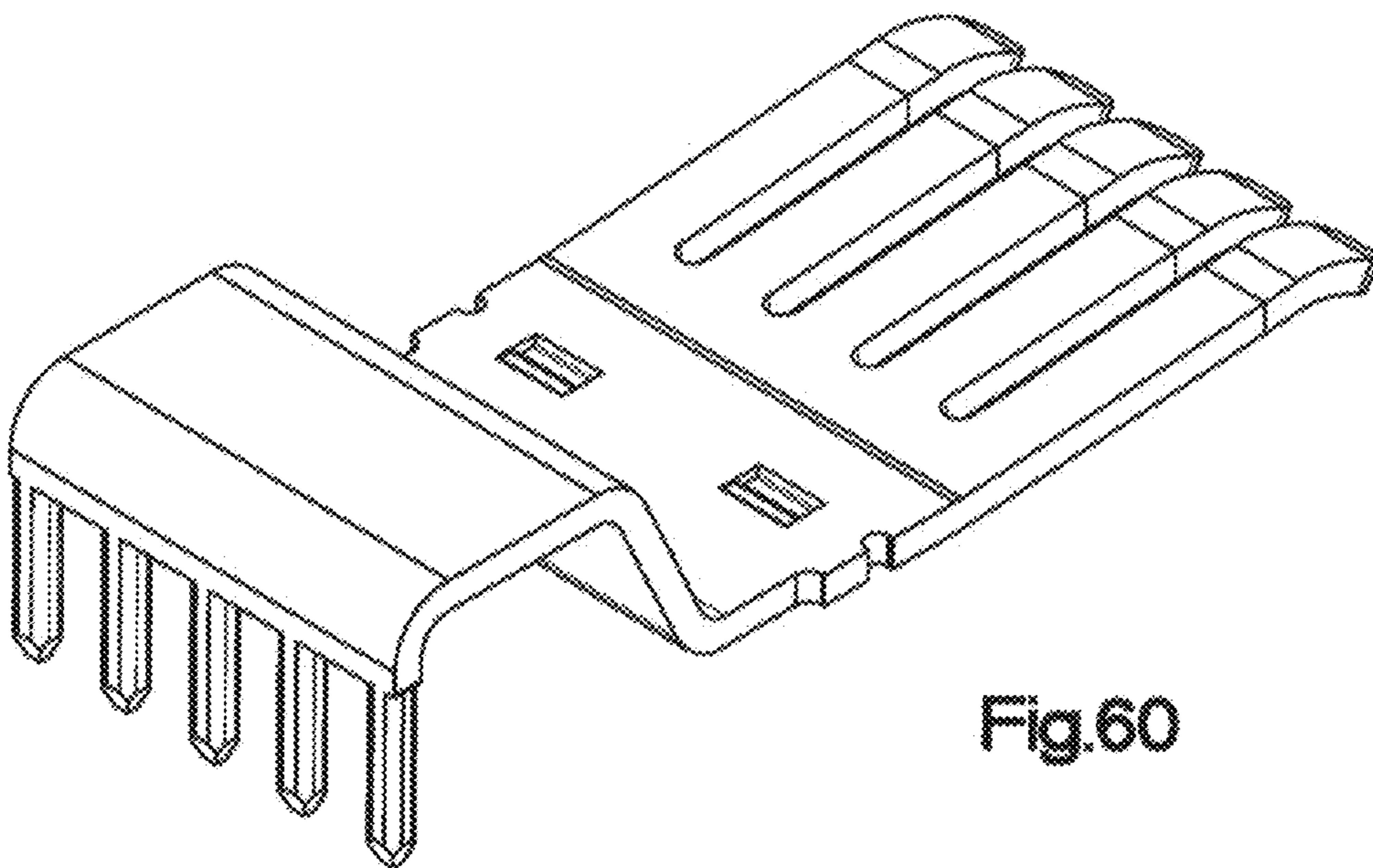
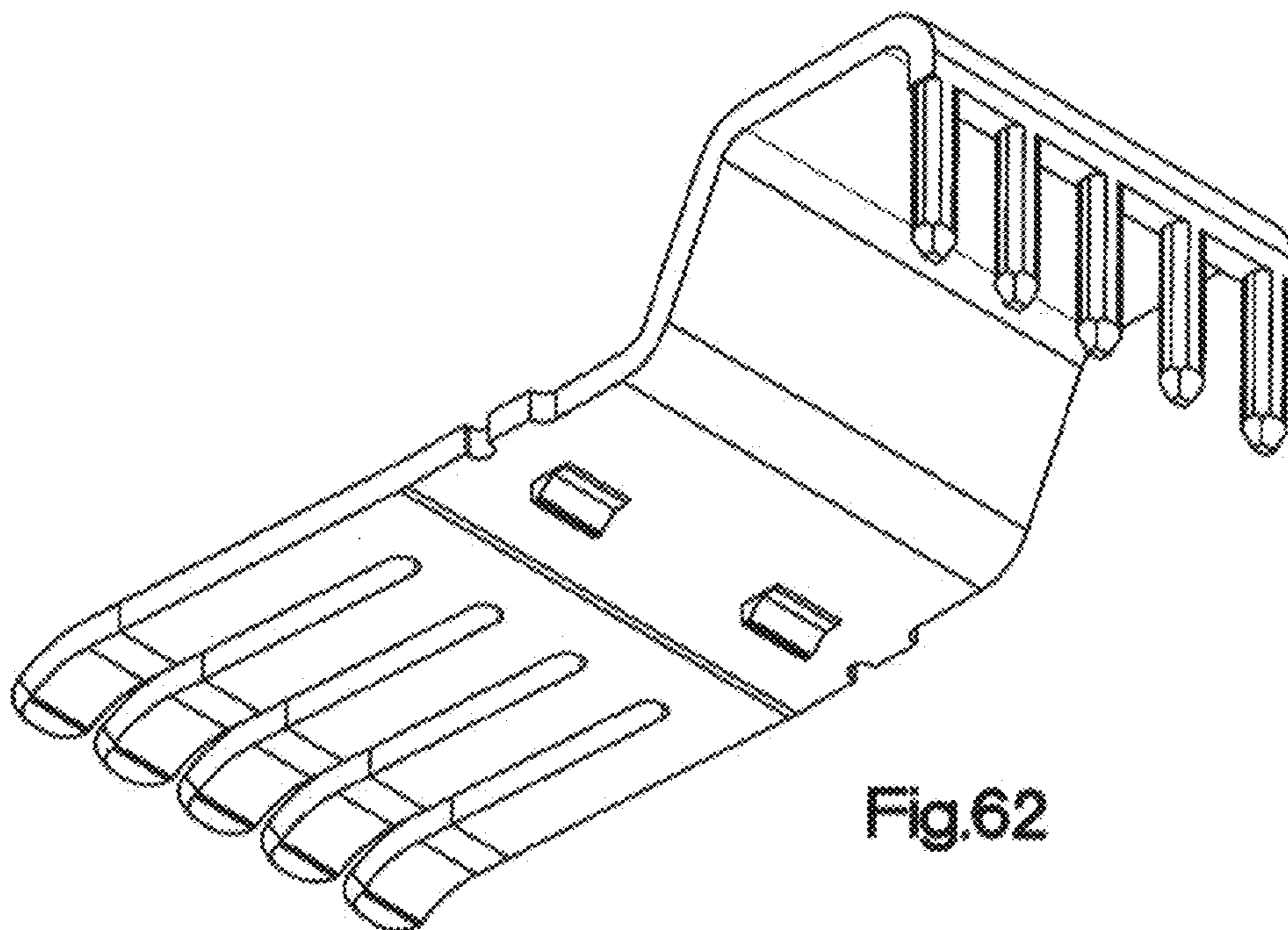
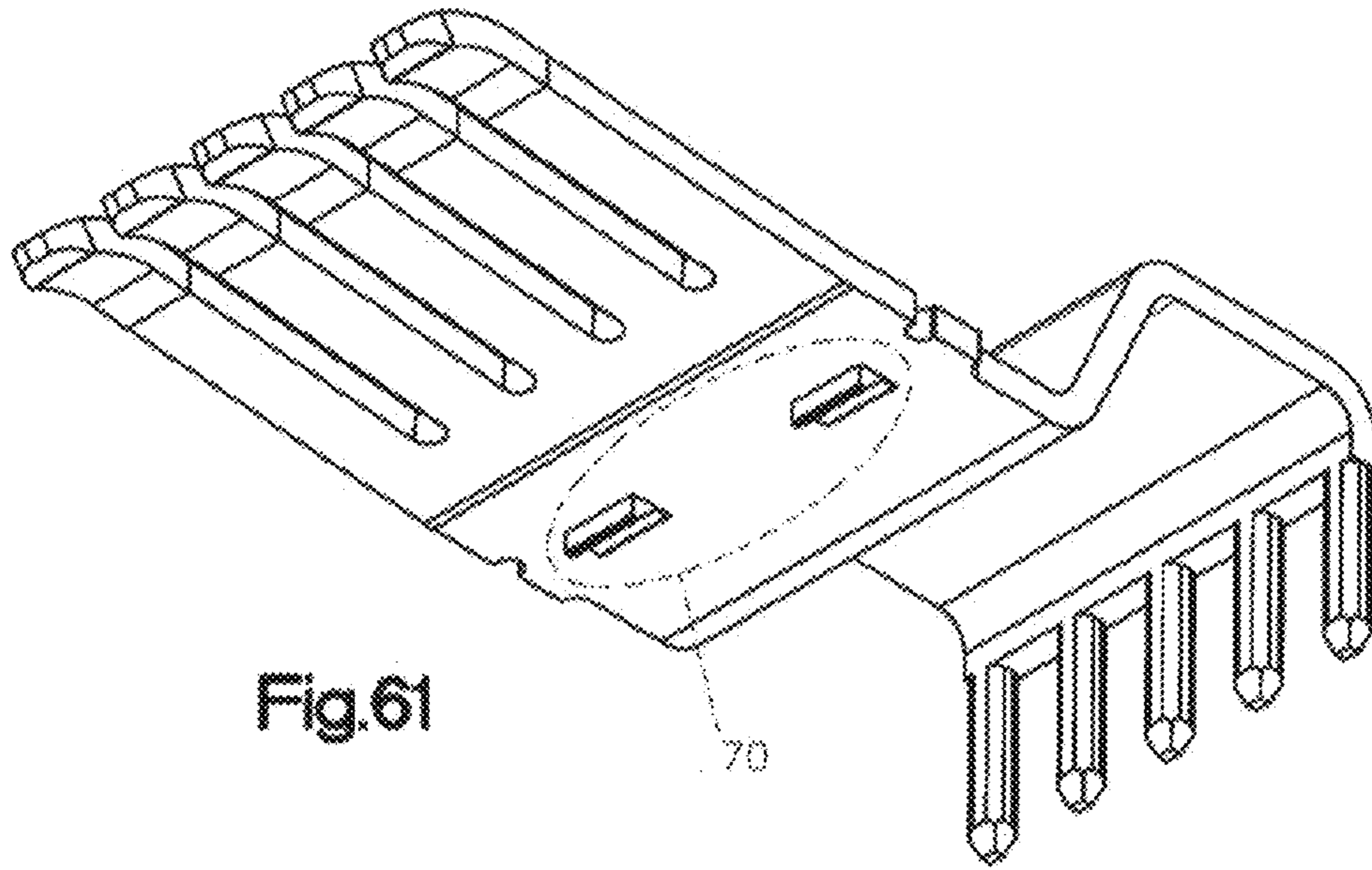

Fig.60



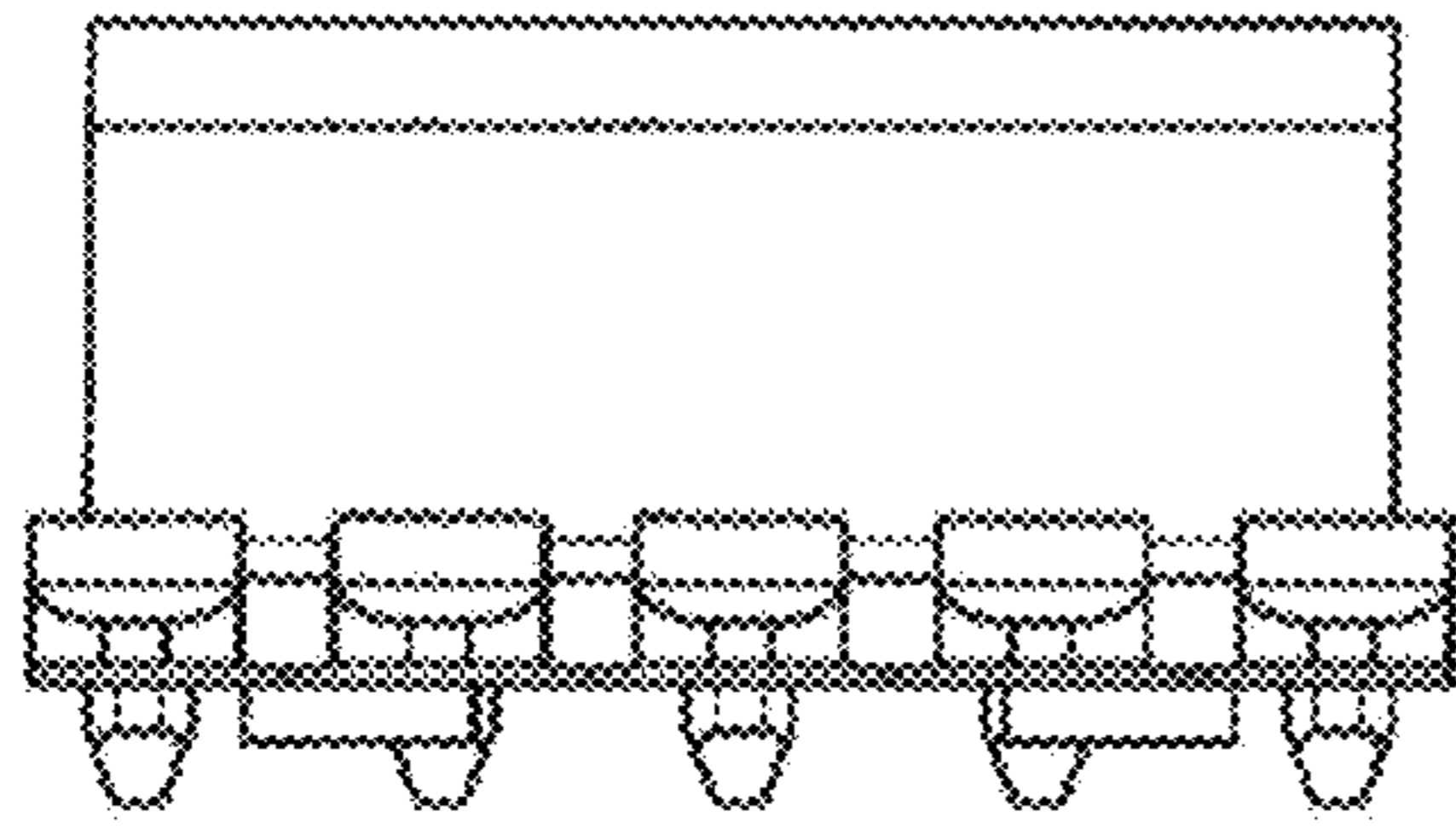

Fig. 63

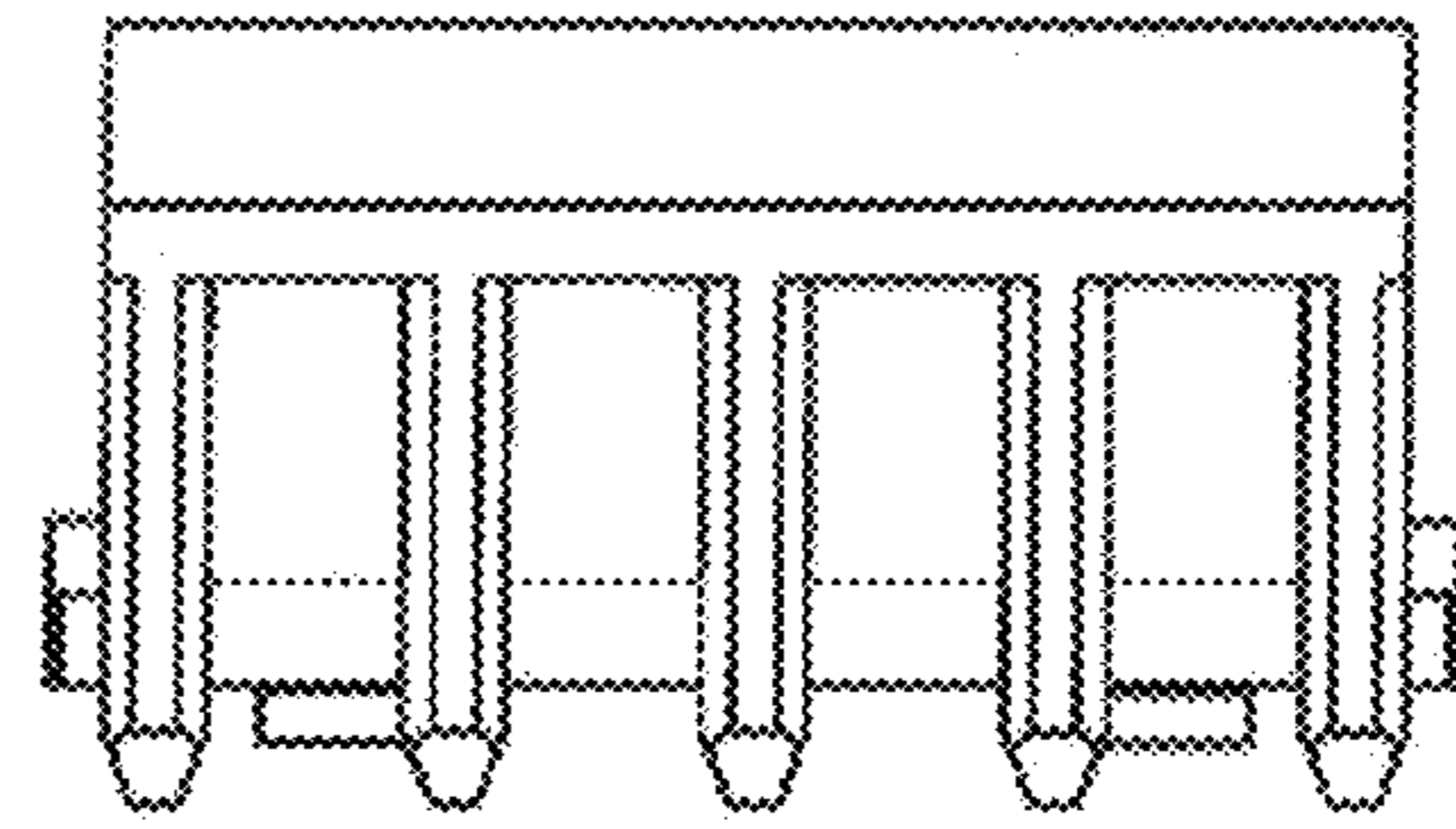

Fig. 64

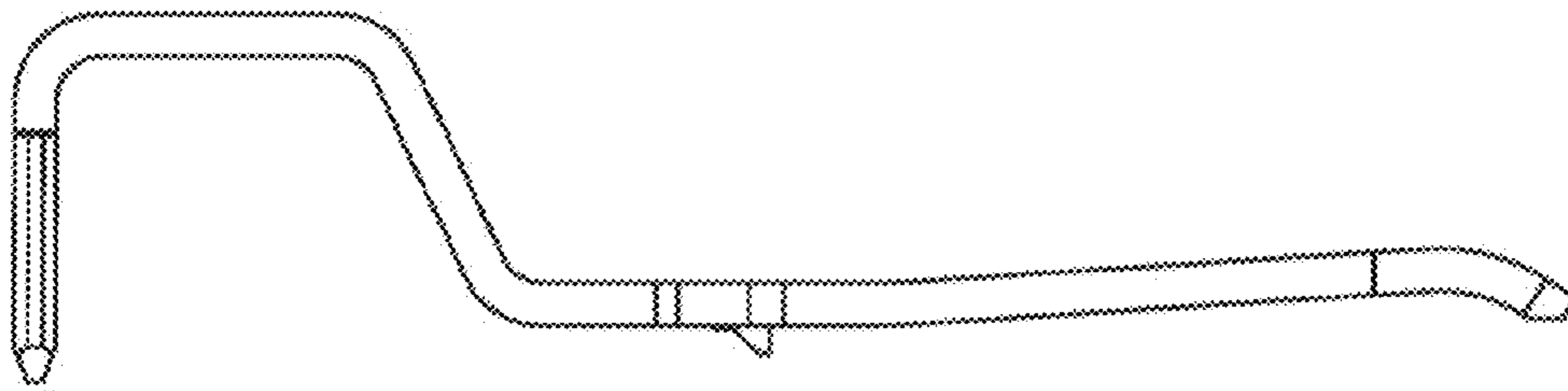

Fig. 65

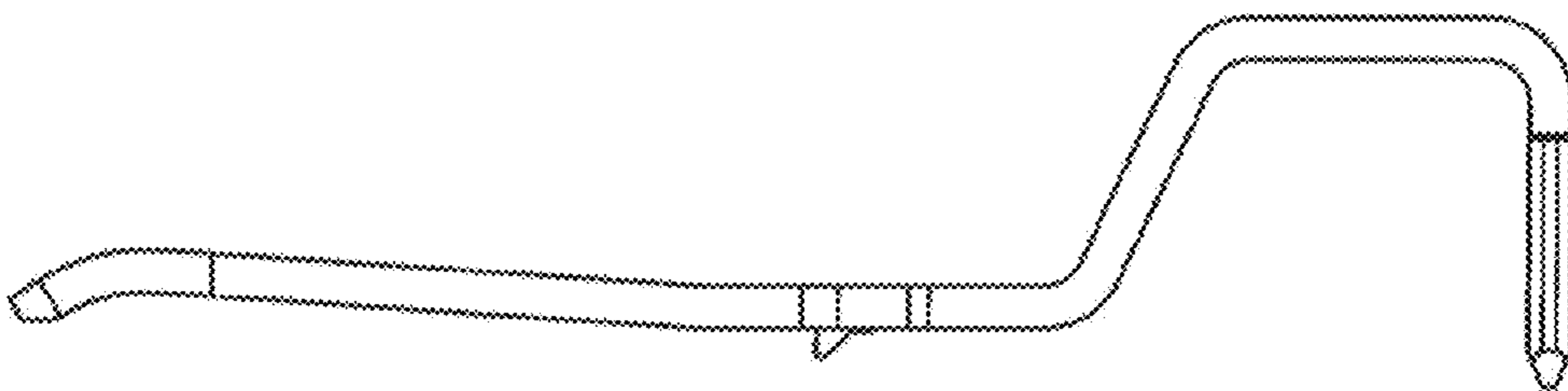

Fig. 66

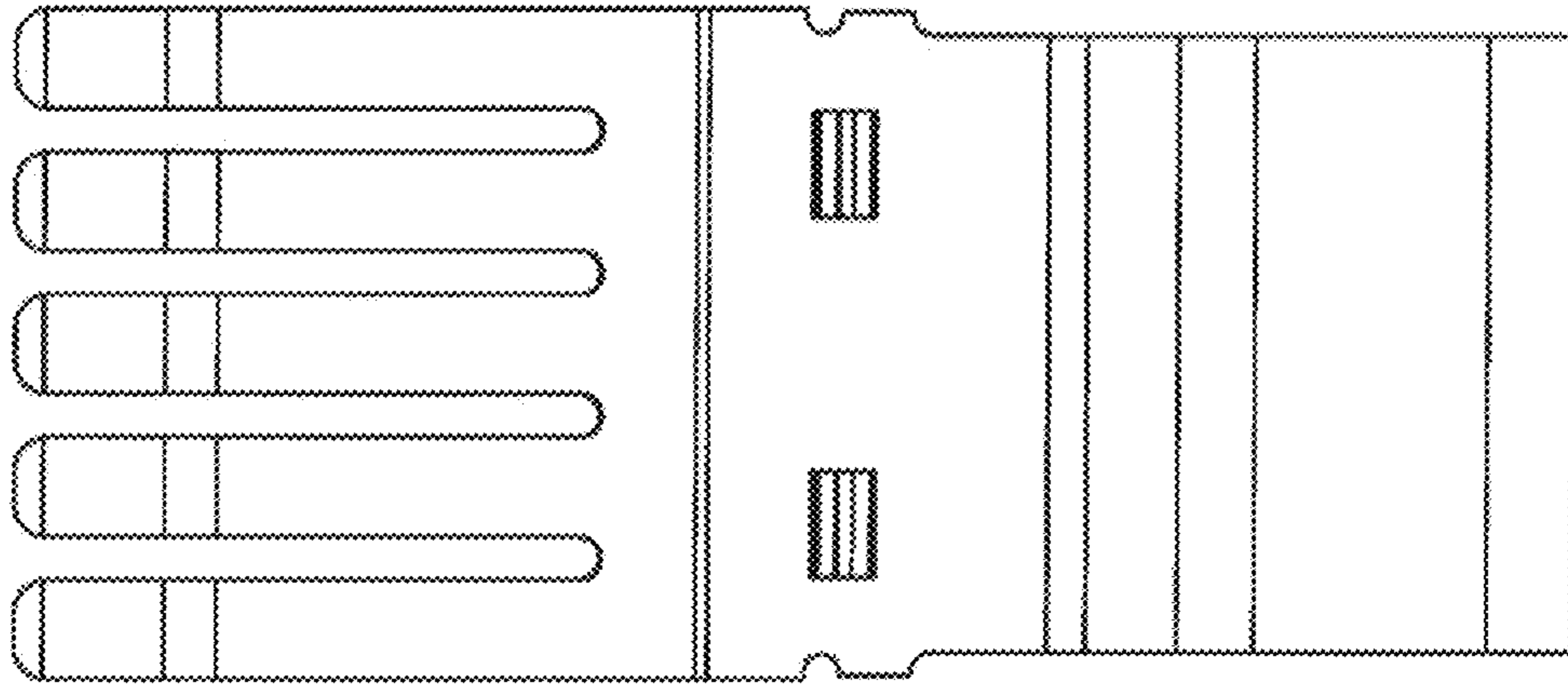

Fig.67

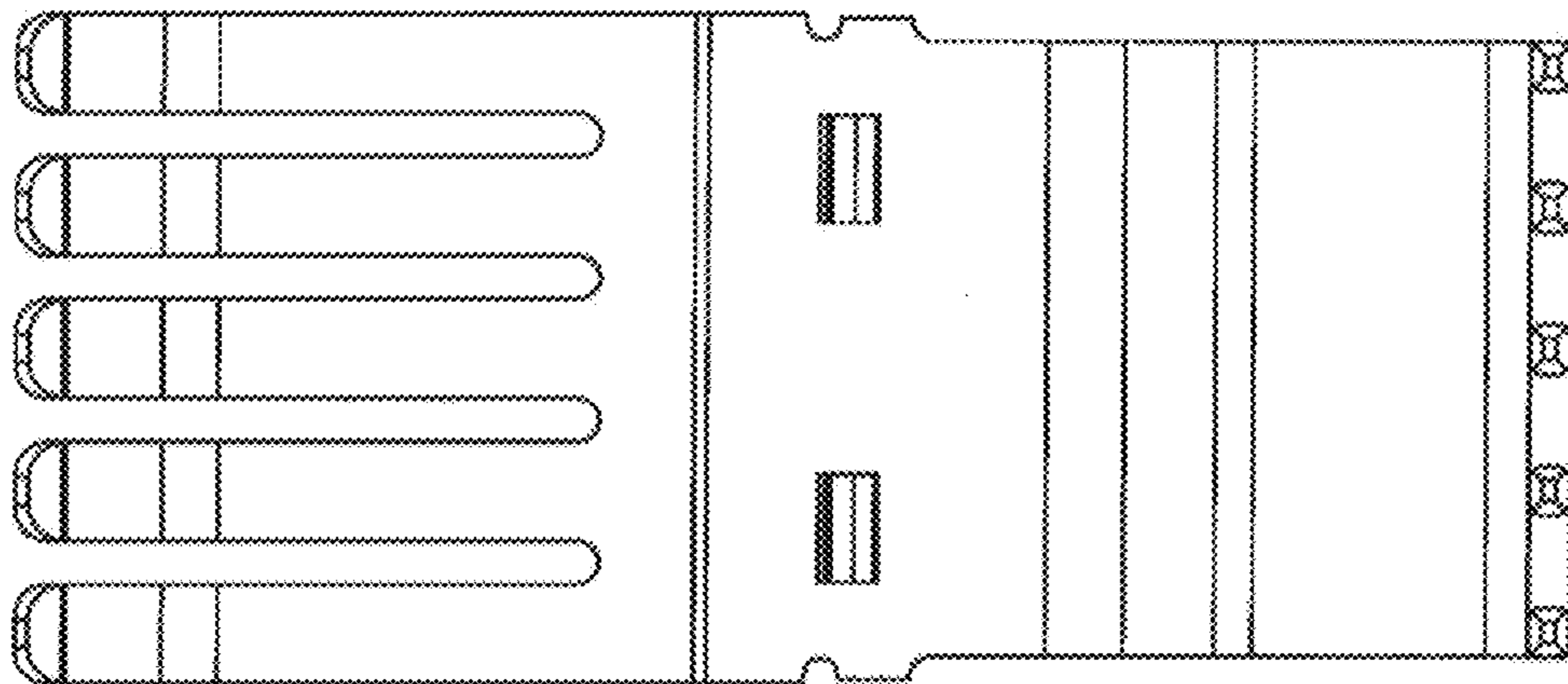

Fig.68

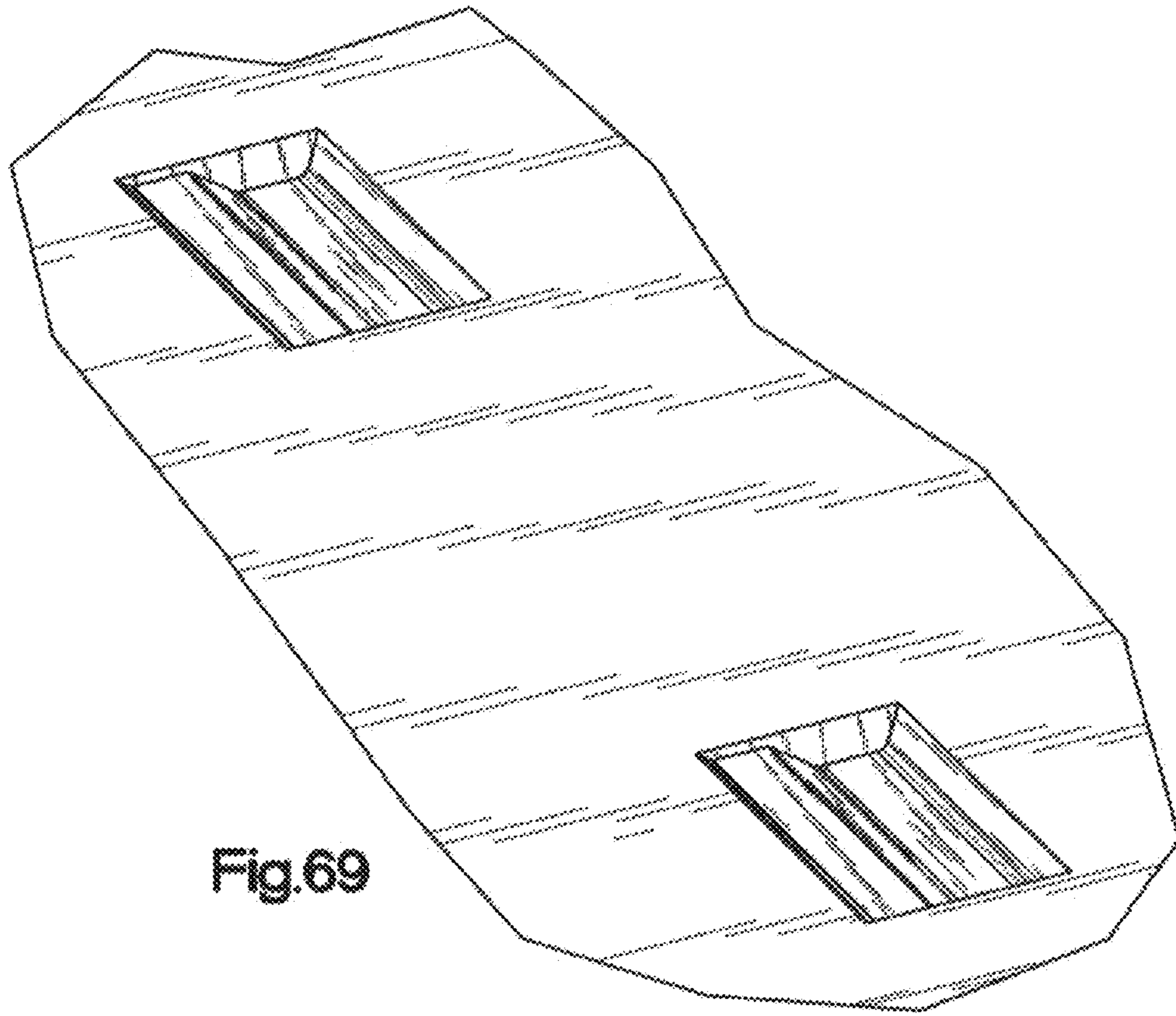

Fig.69

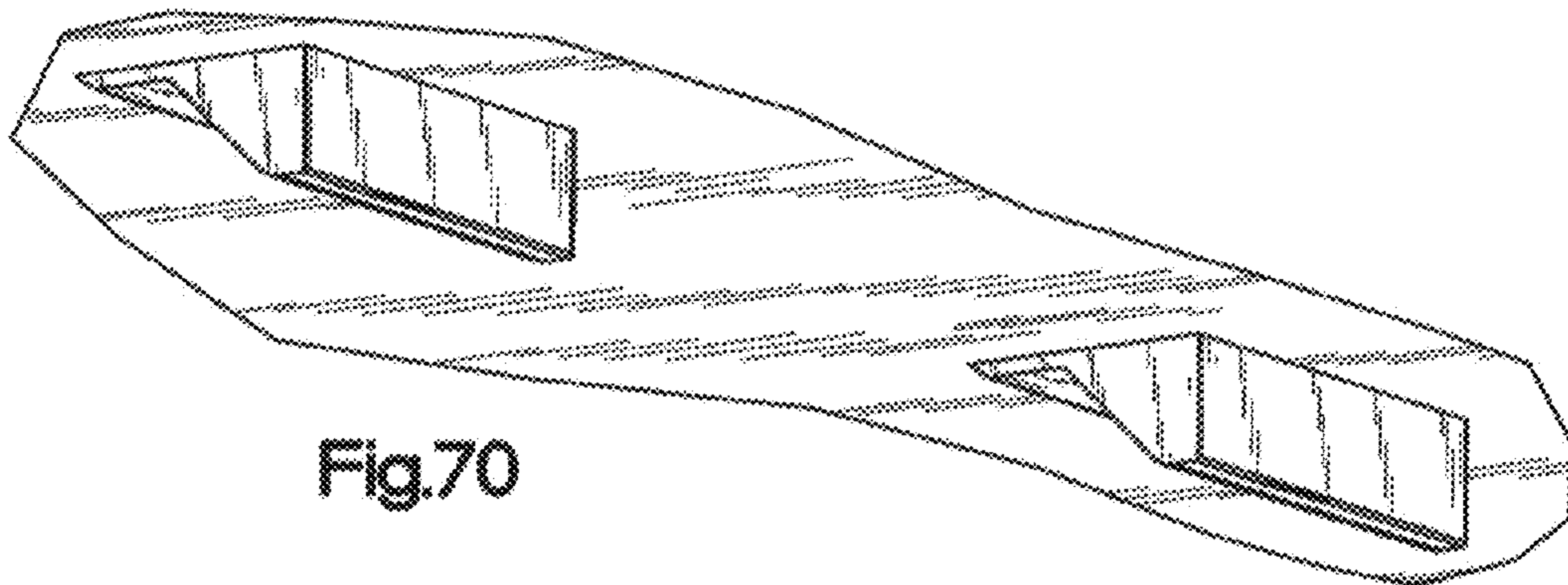

Fig.70

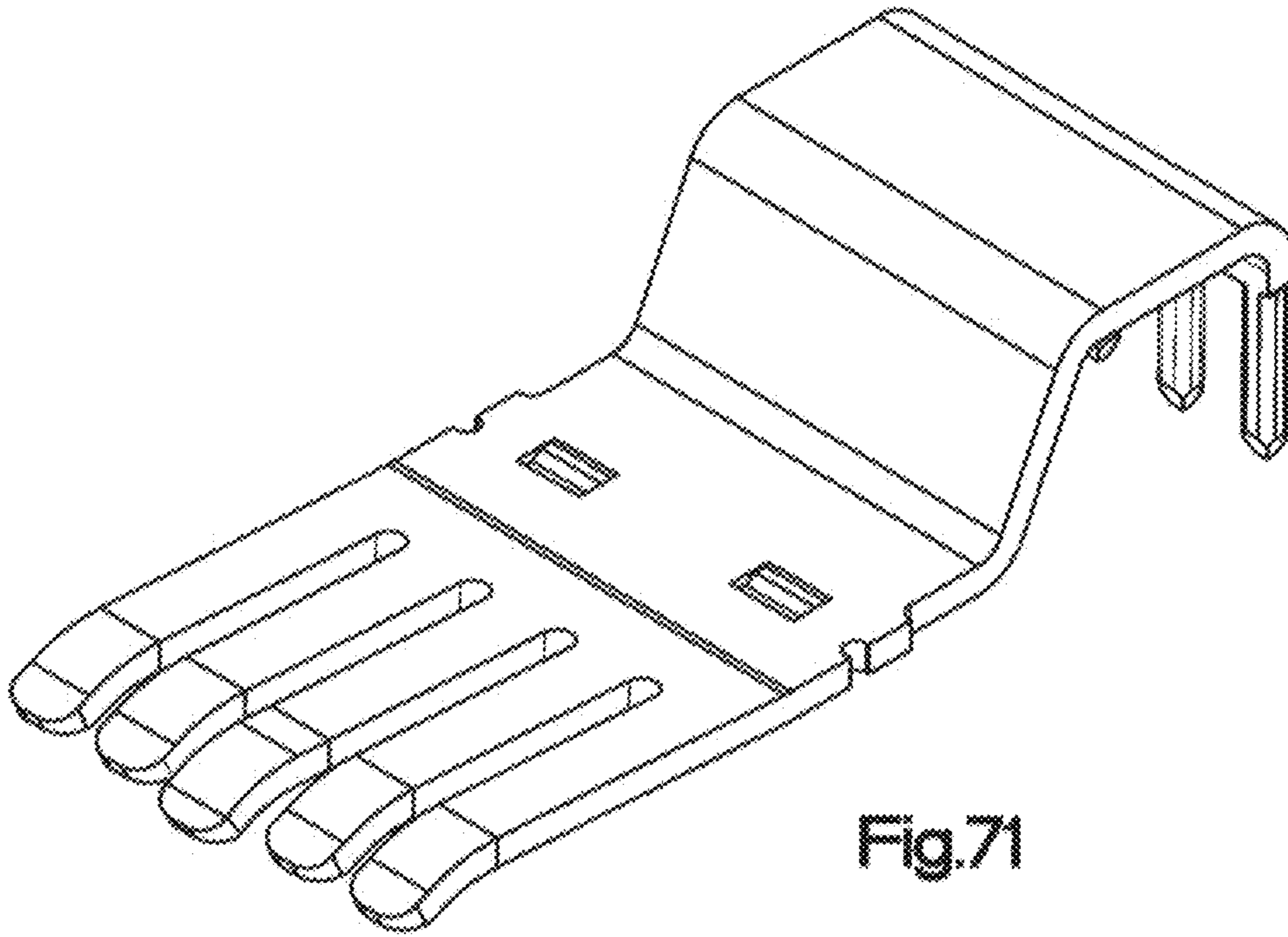

Fig.71

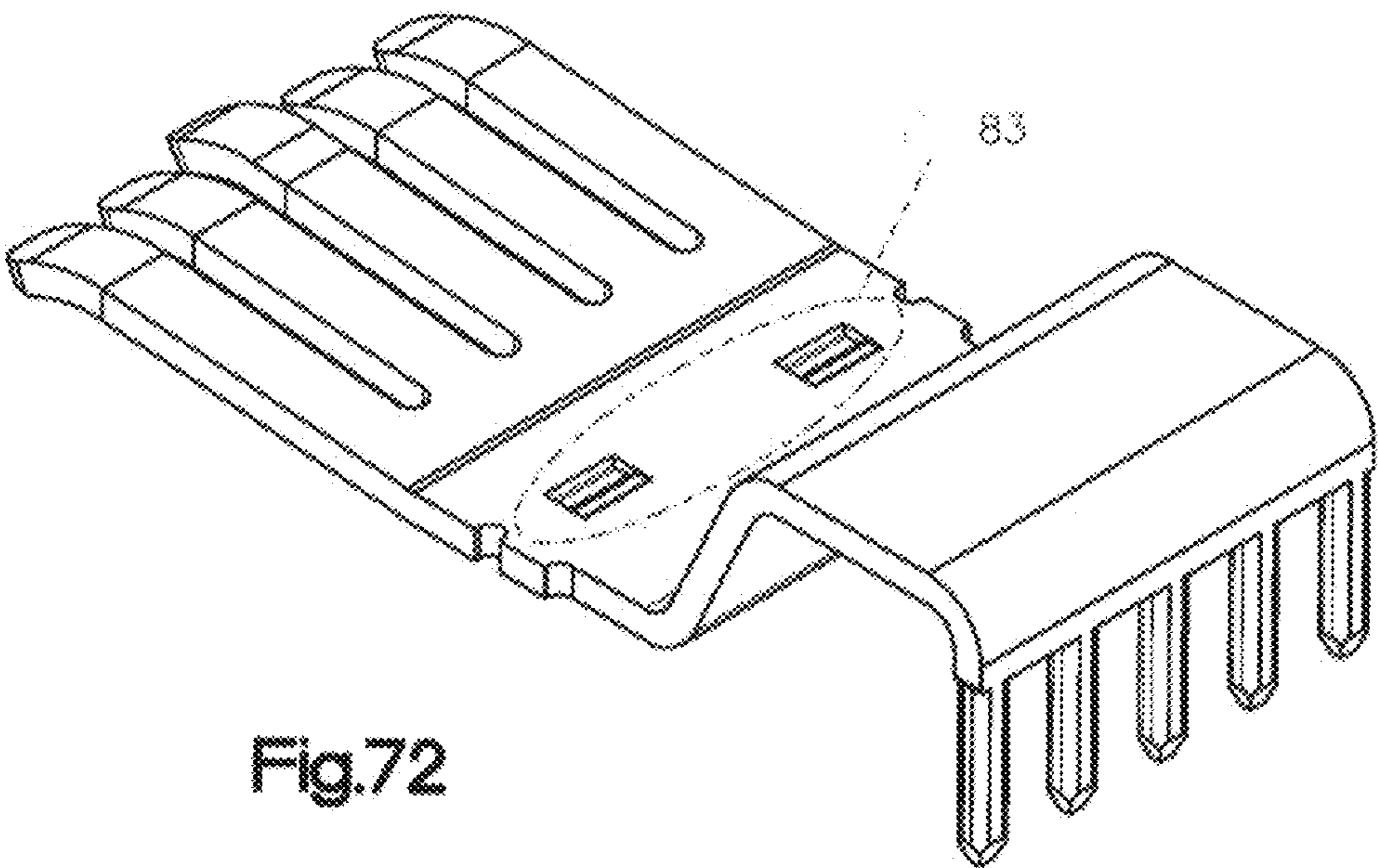

Fig.72

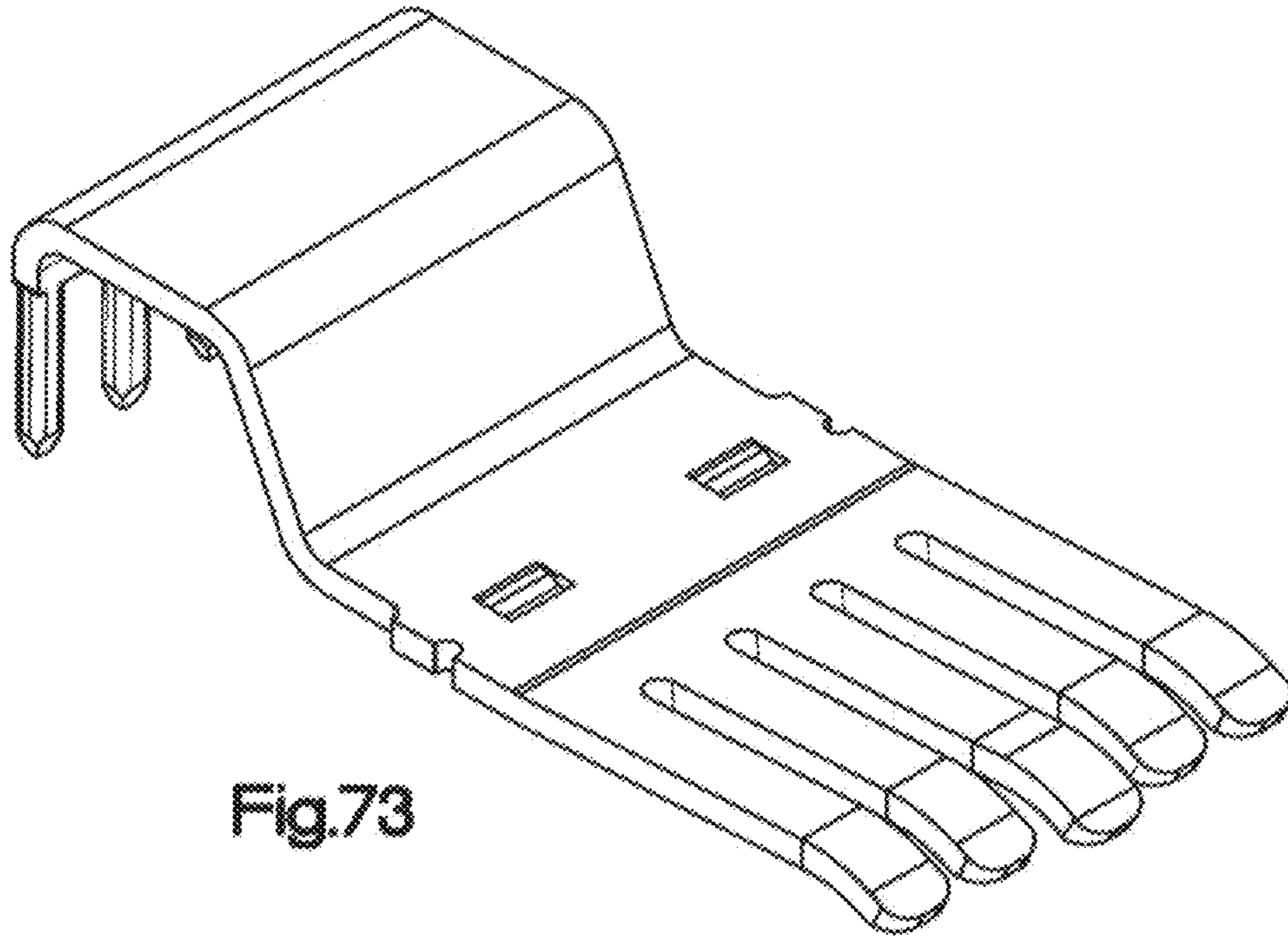

Fig.73

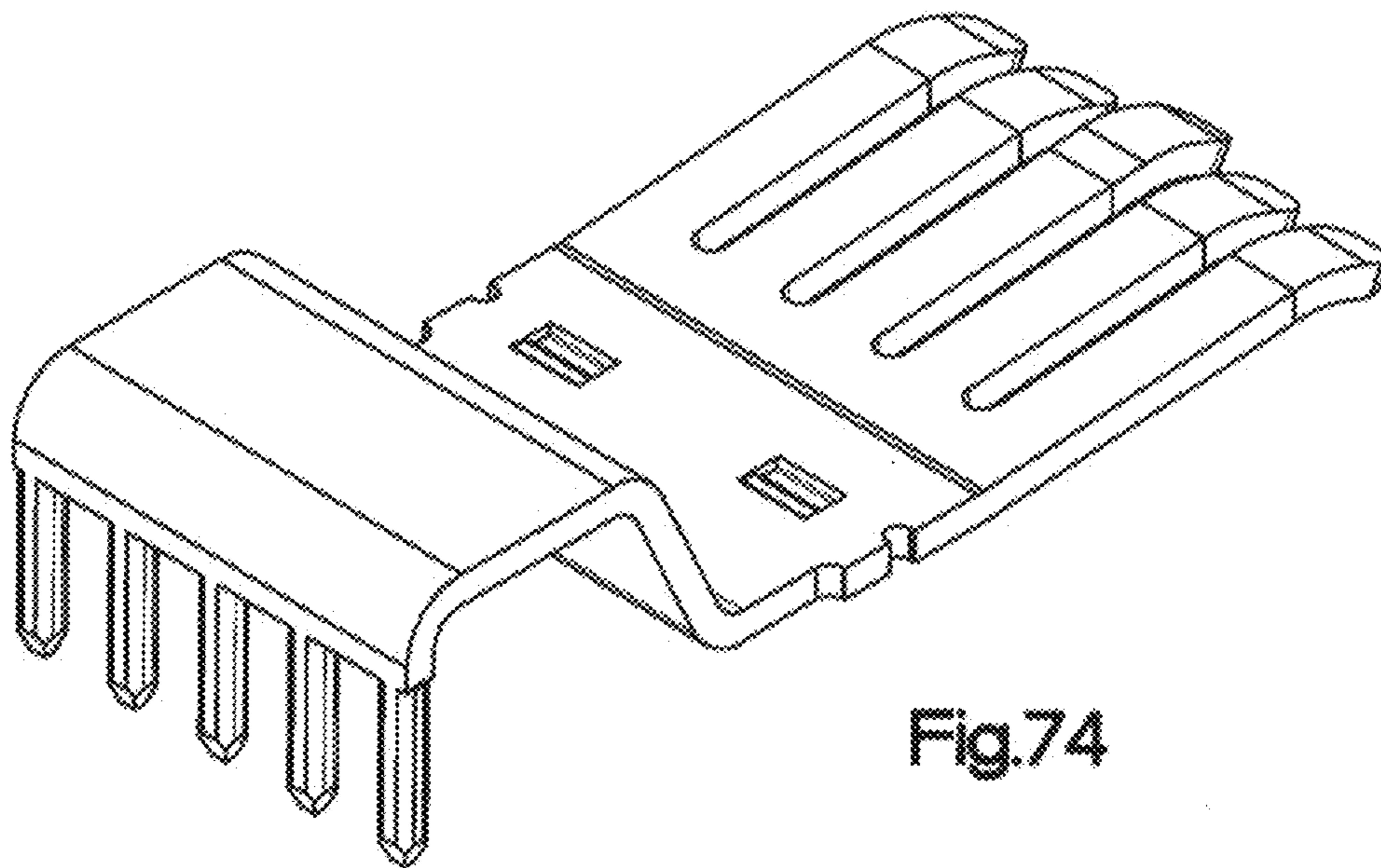
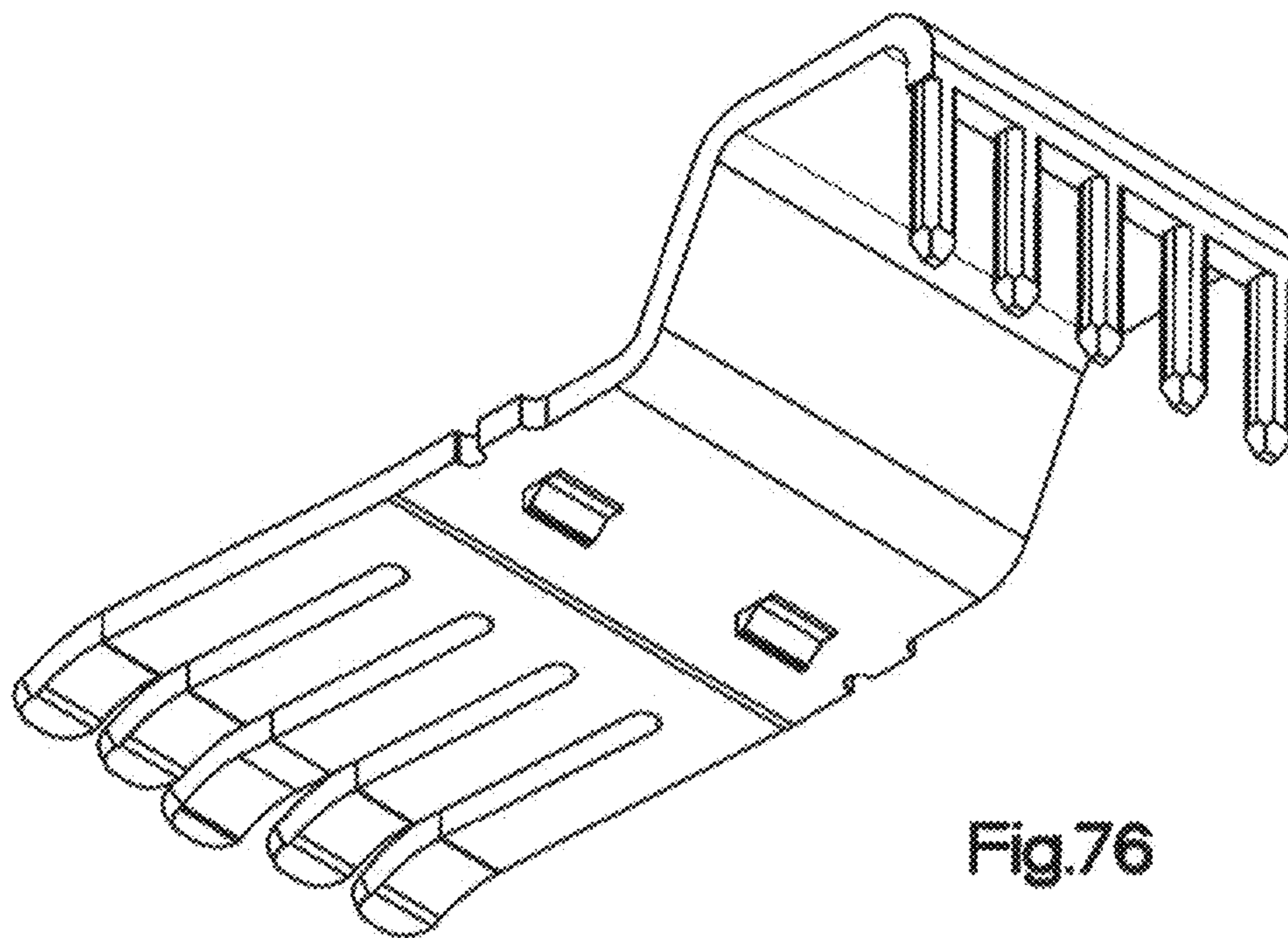
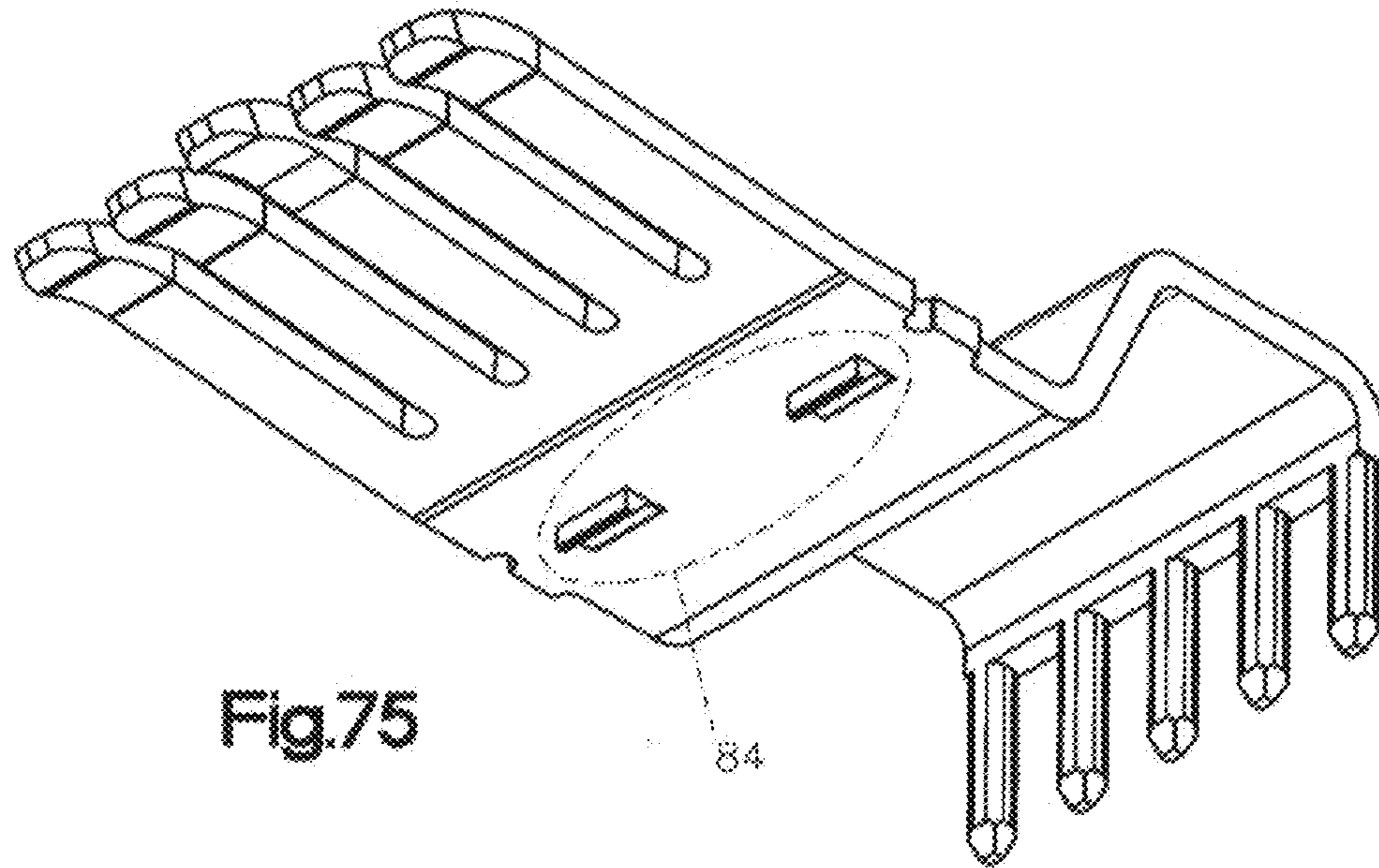

Fig.74



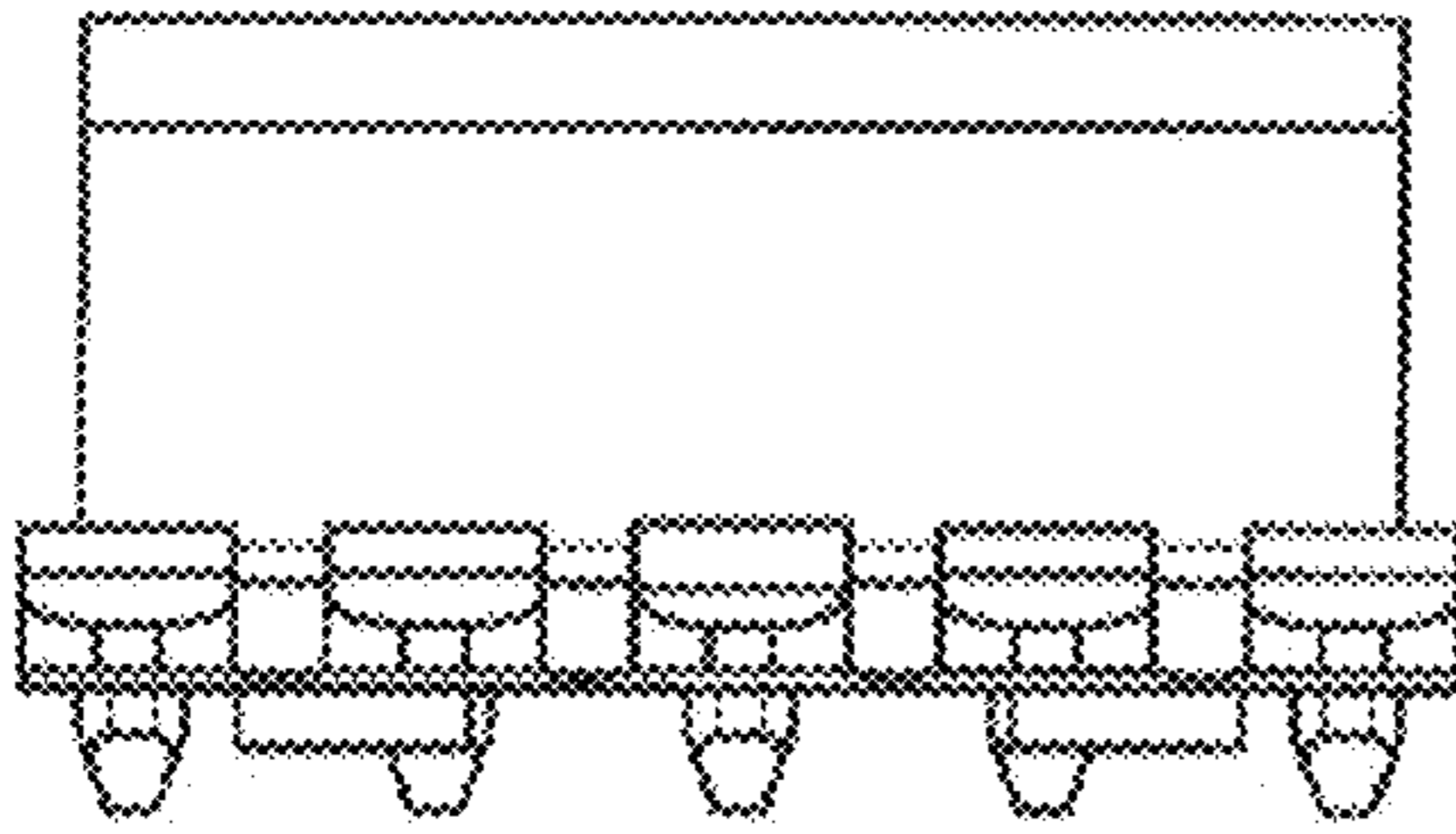

Fig.77

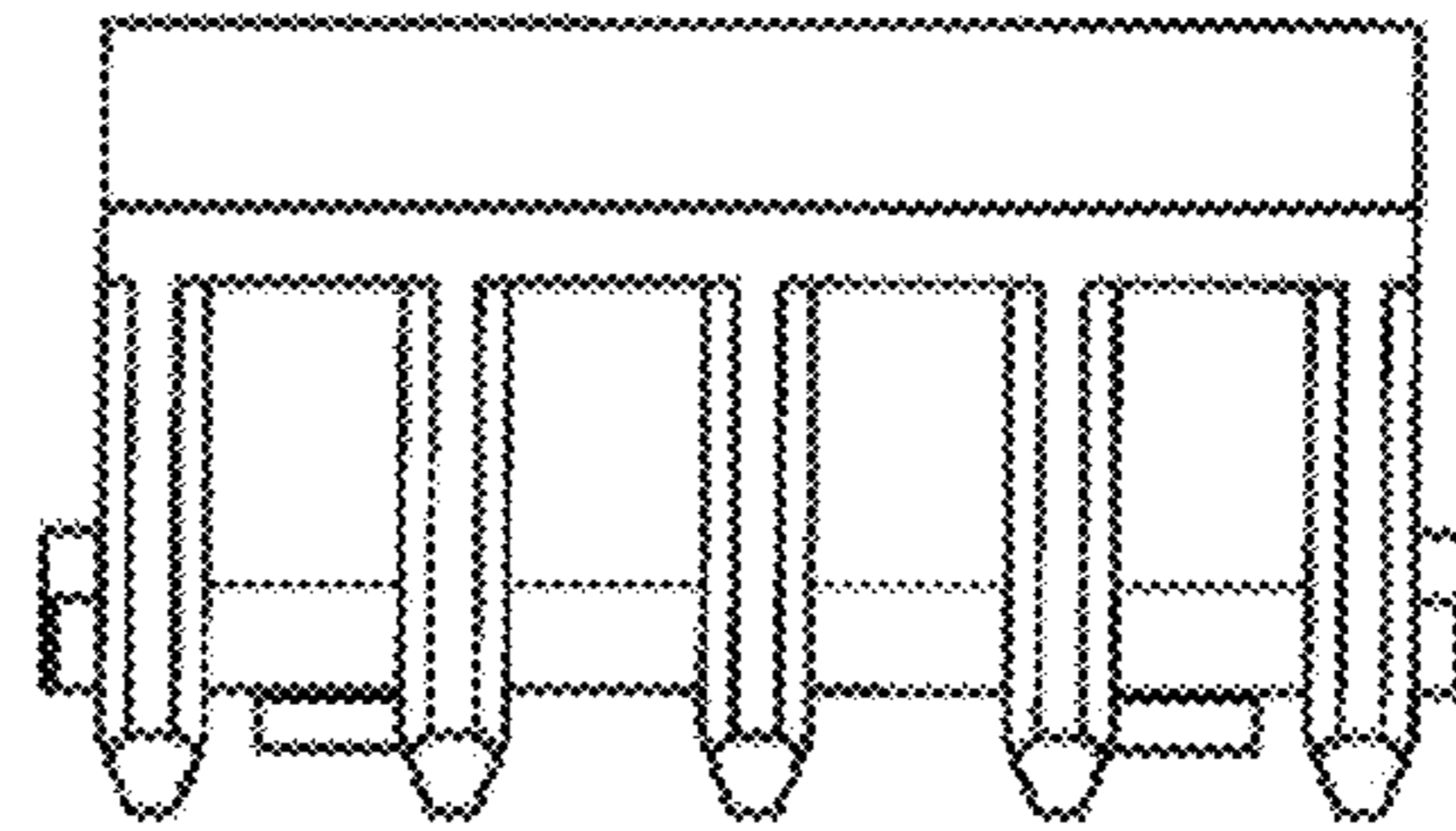

Fig.78

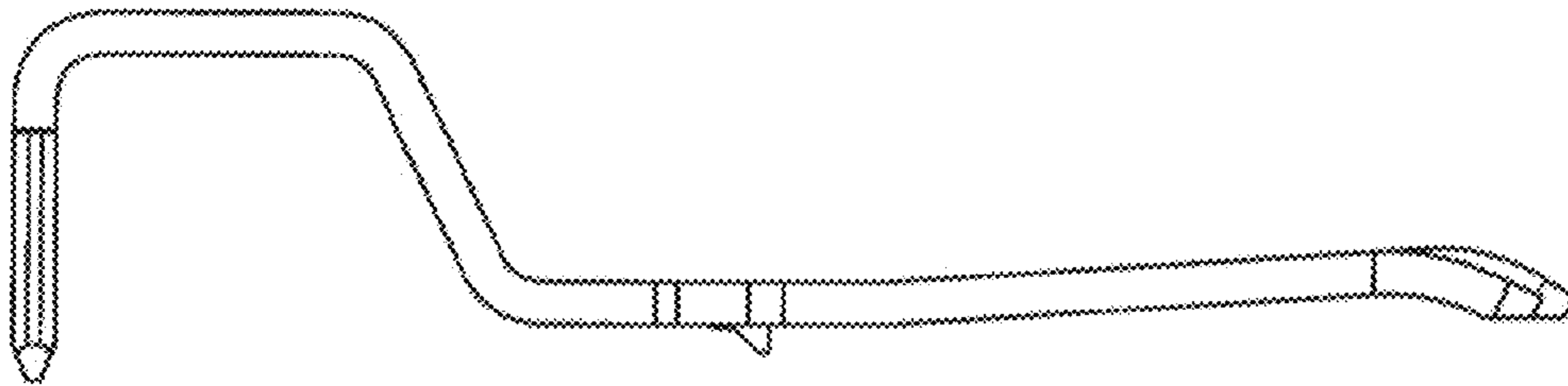

Fig.79

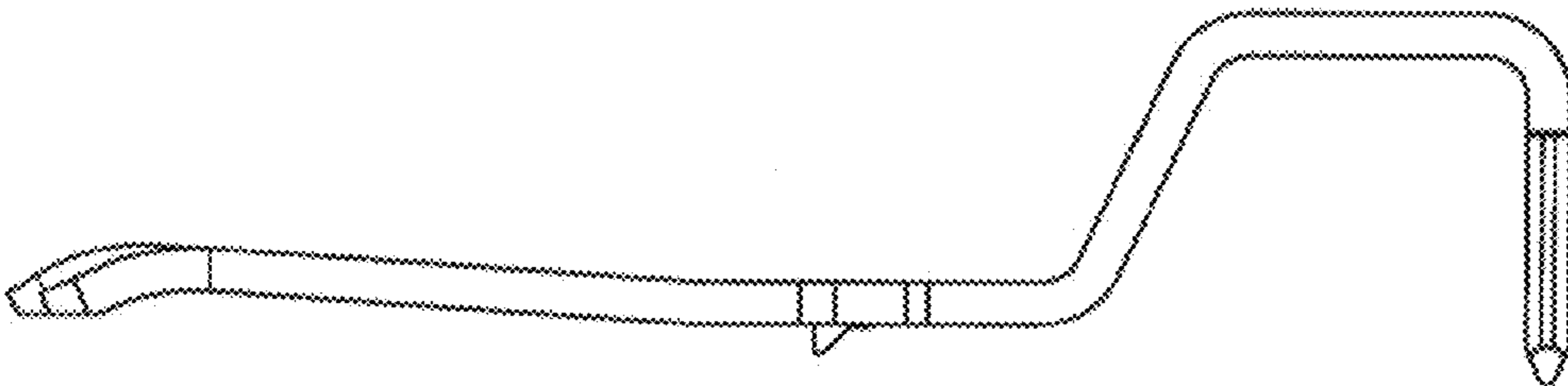

Fig.80

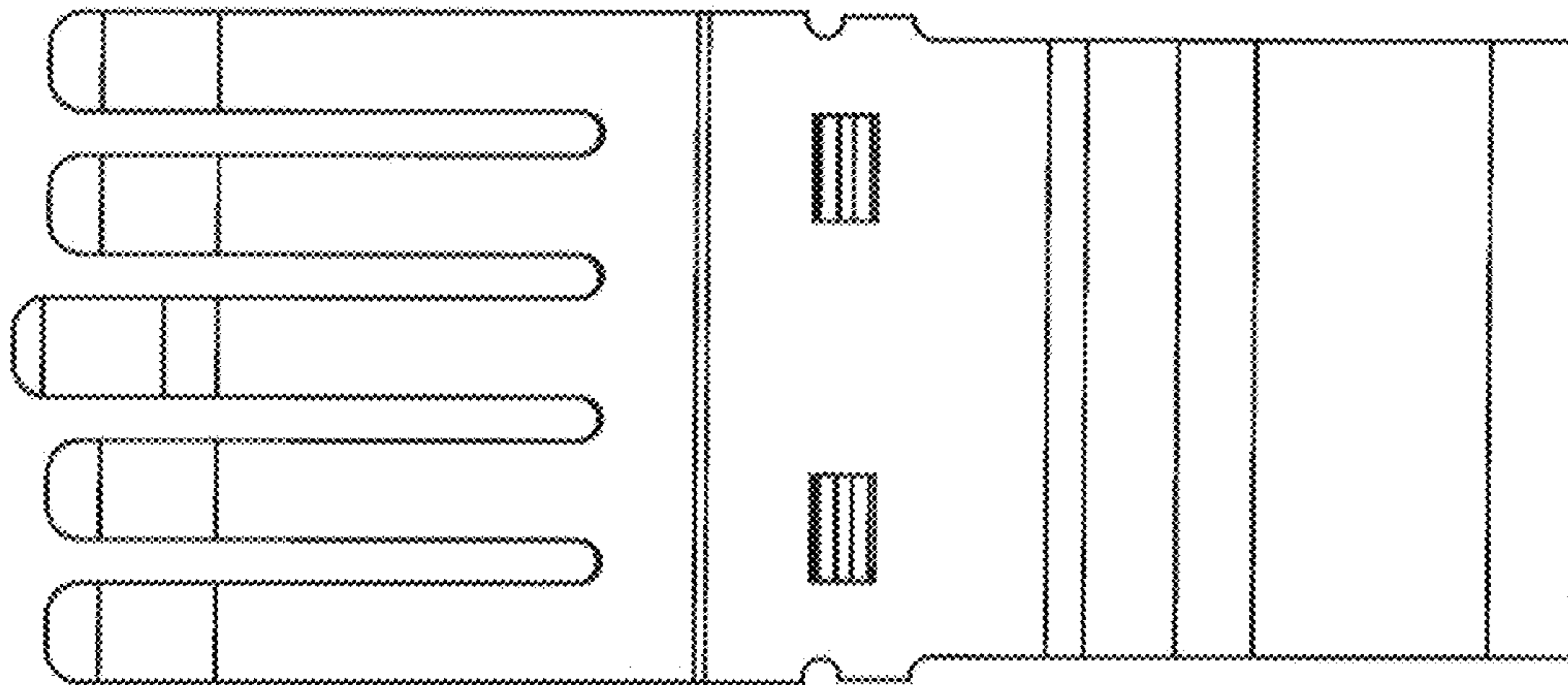

Fig.81

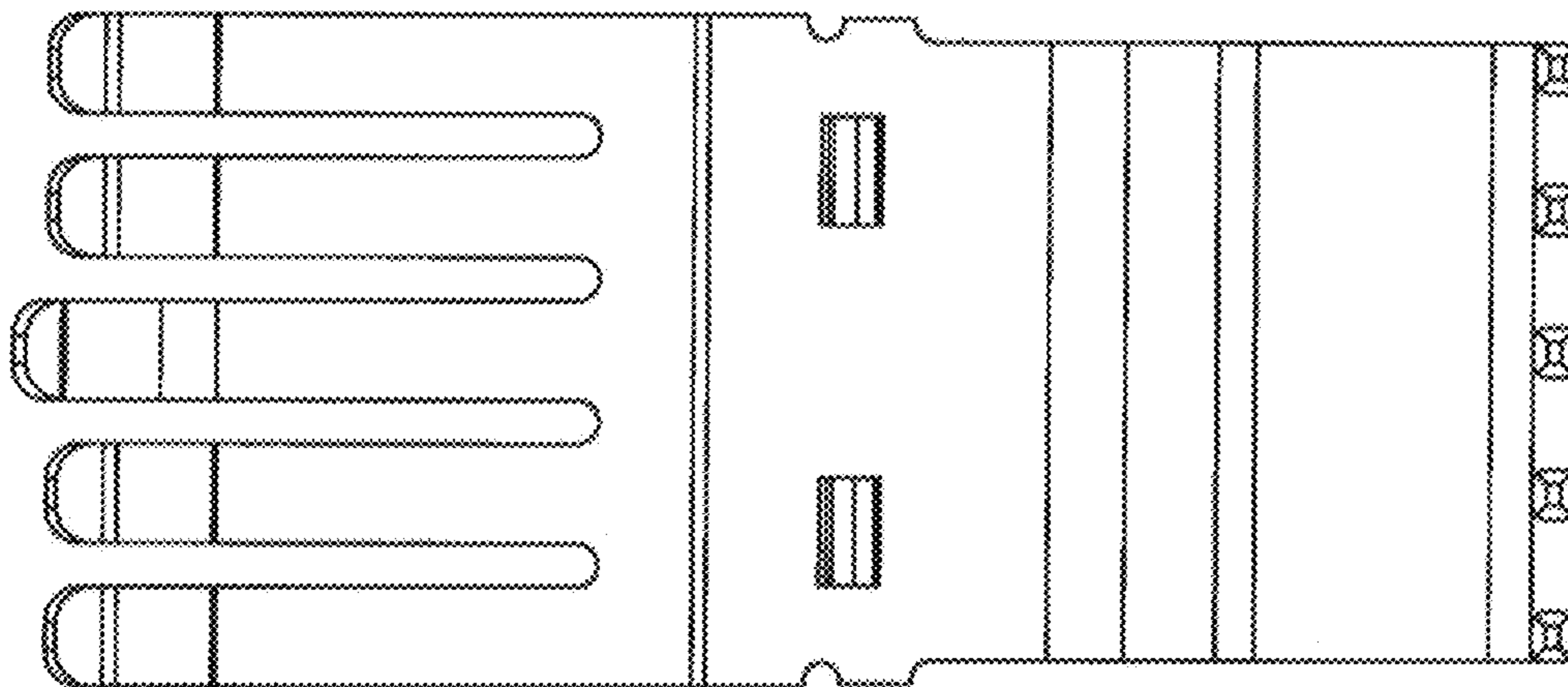

Fig.82

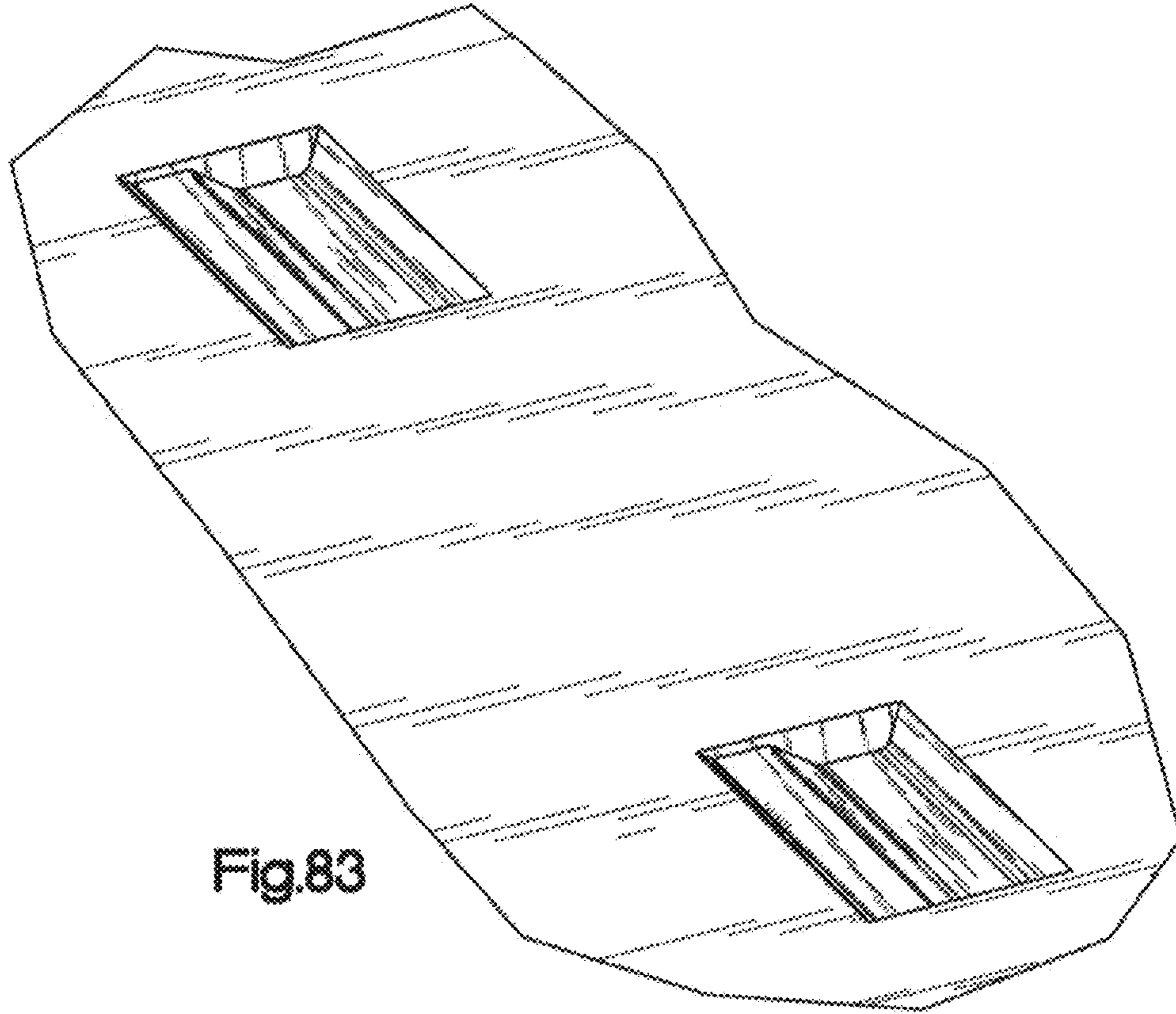

Fig.83

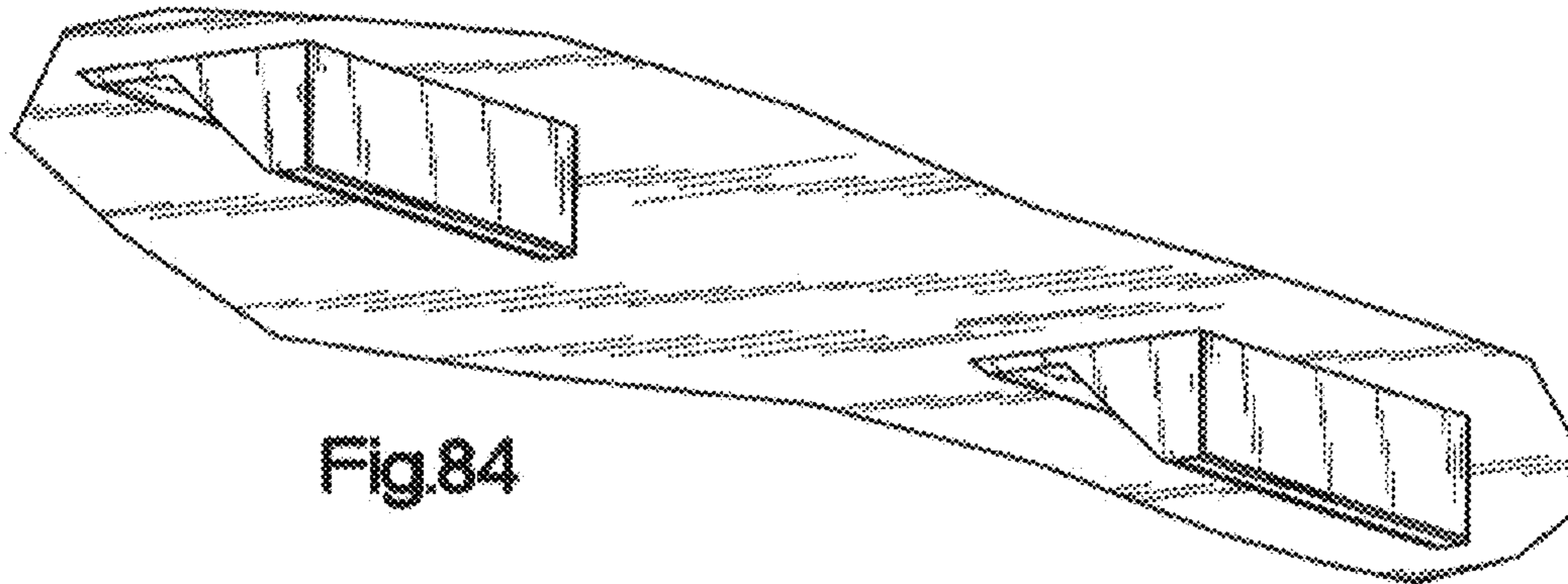

Fig.84

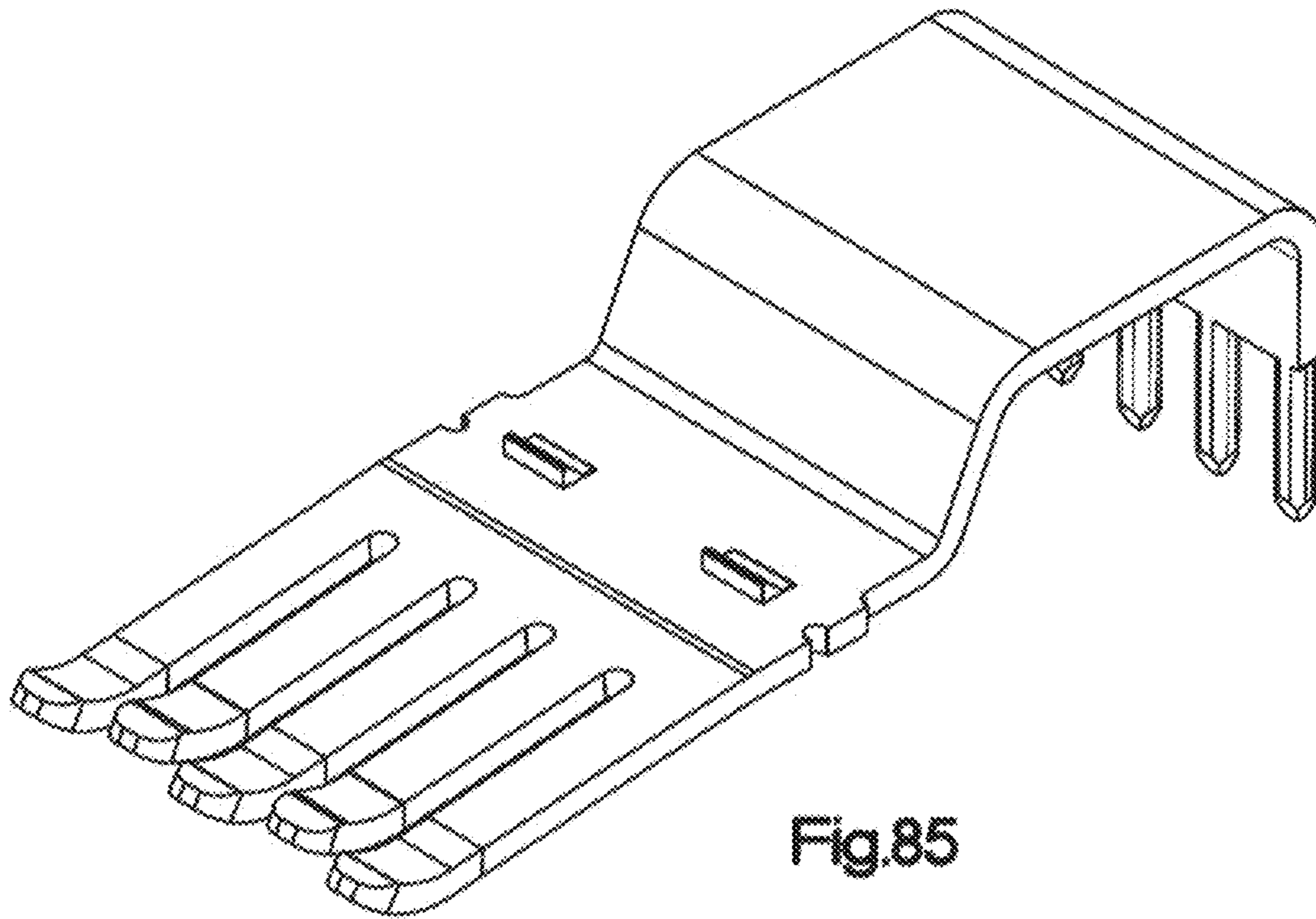

Fig.85

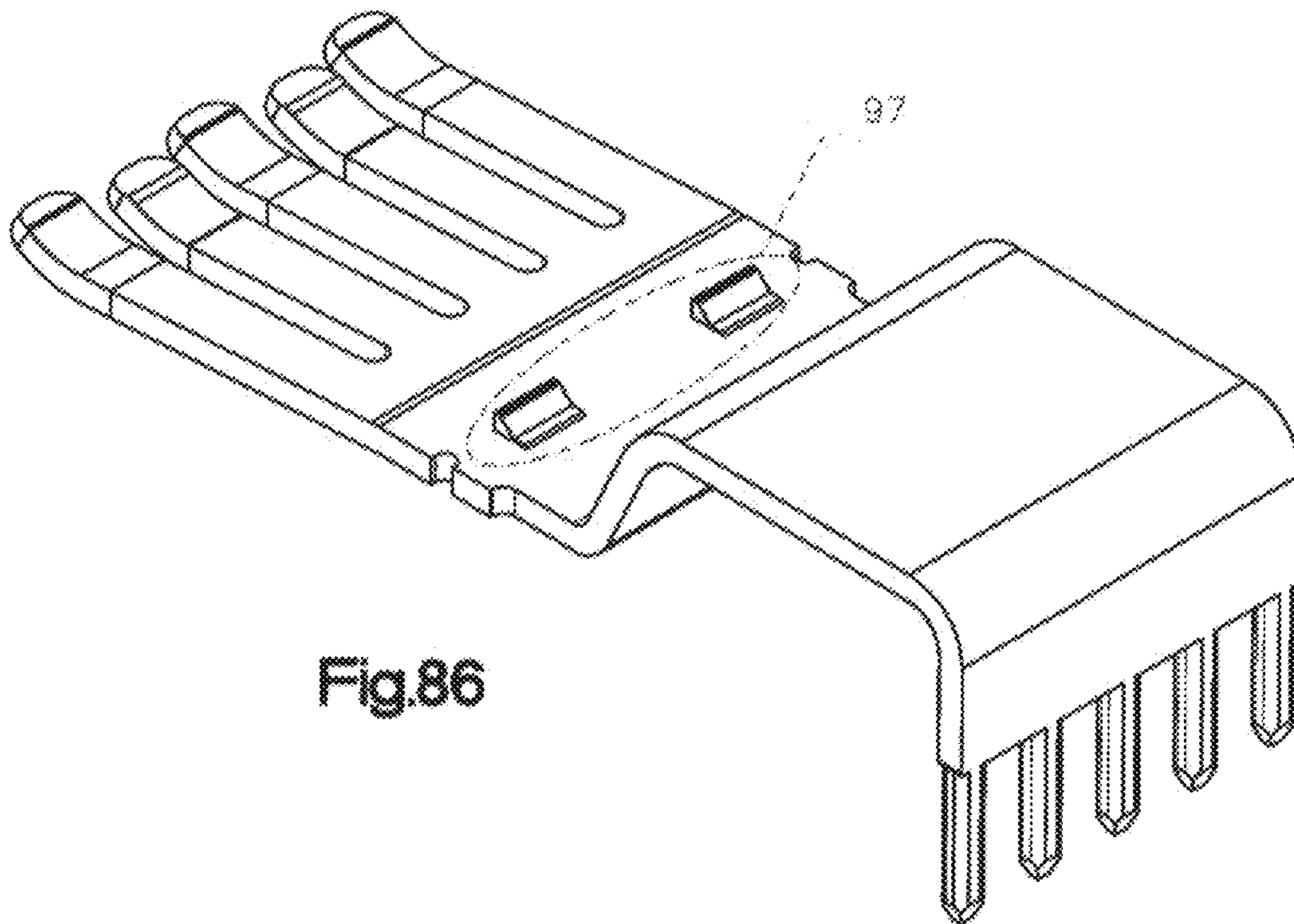

Fig.86

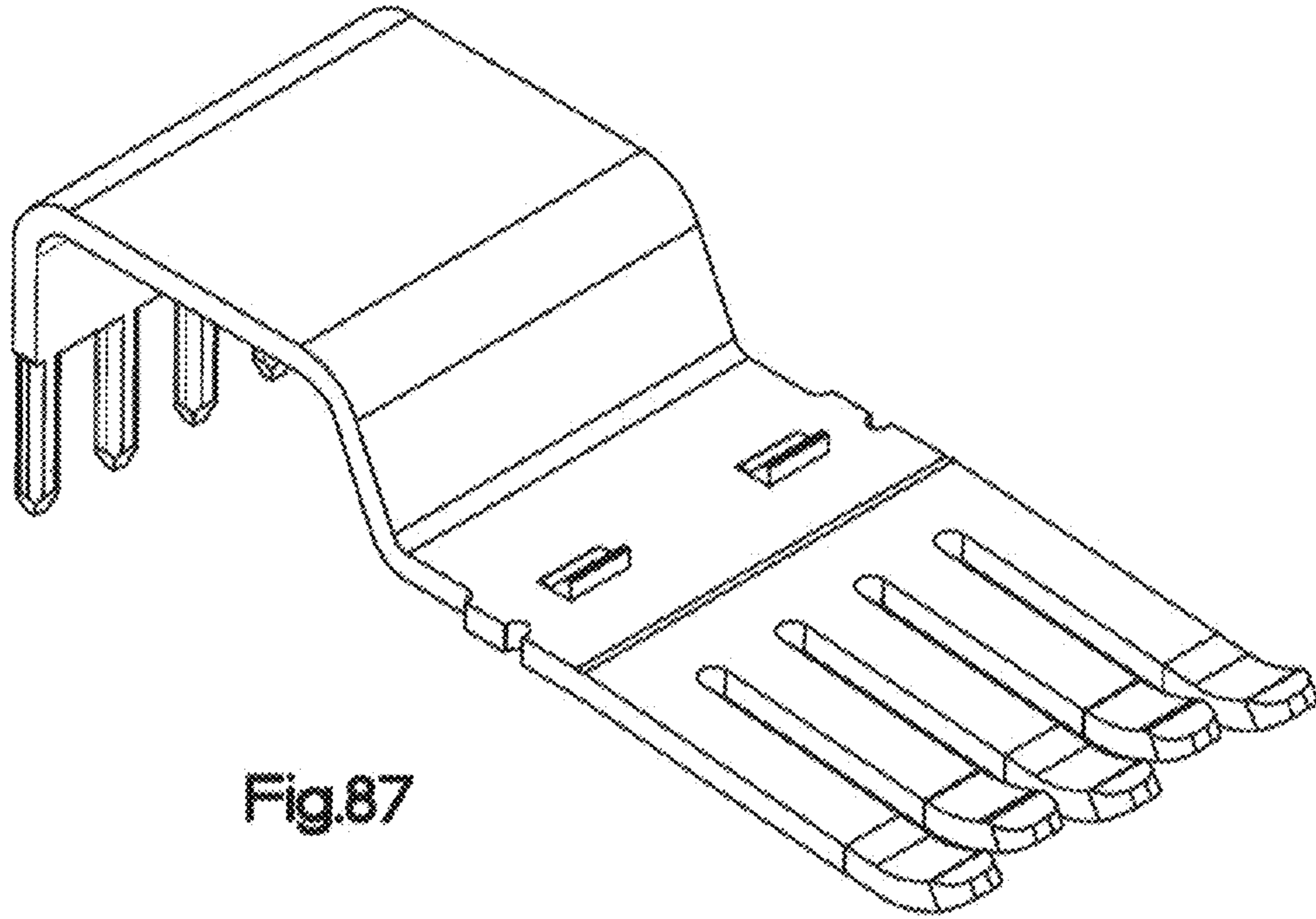

Fig.87

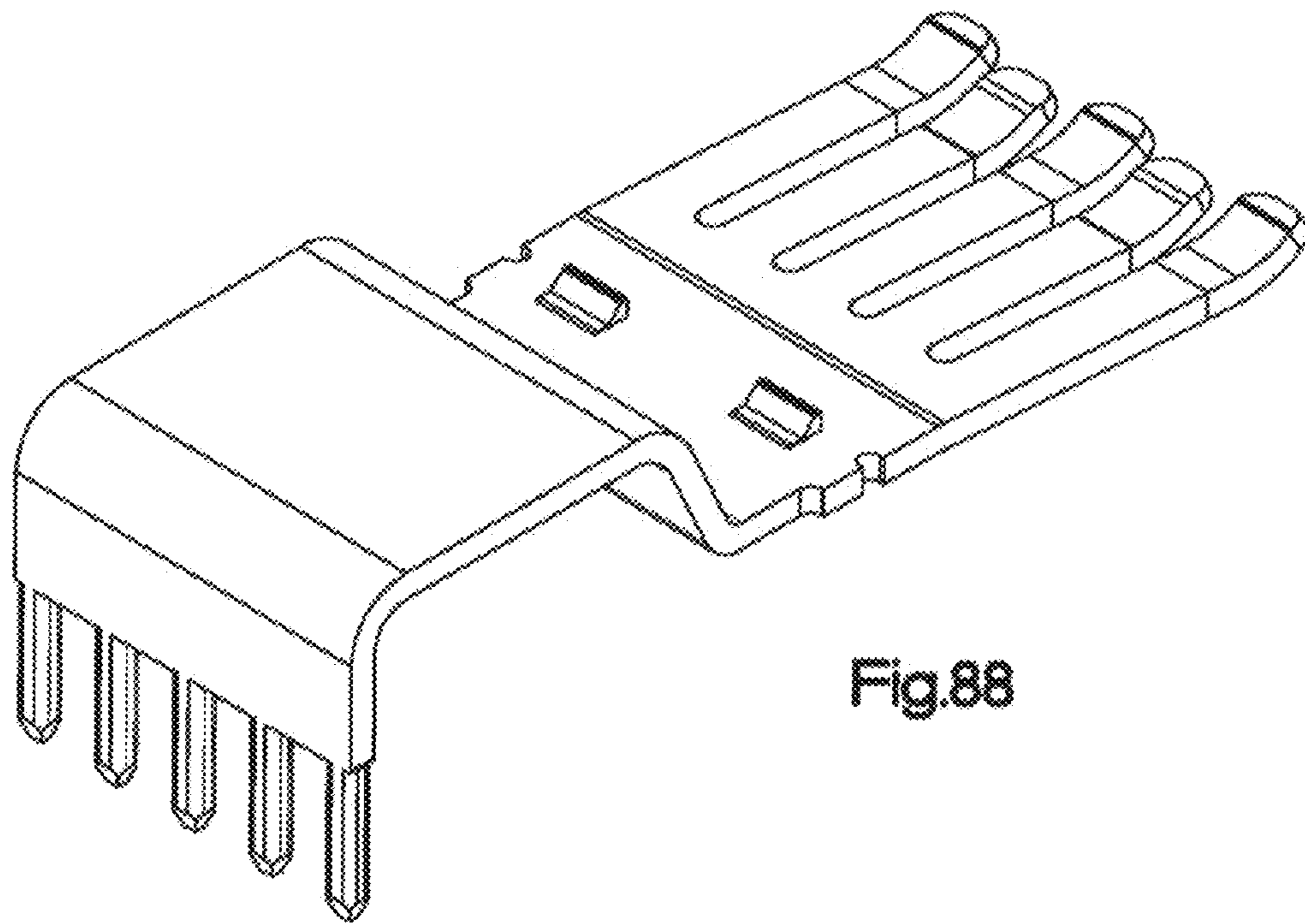
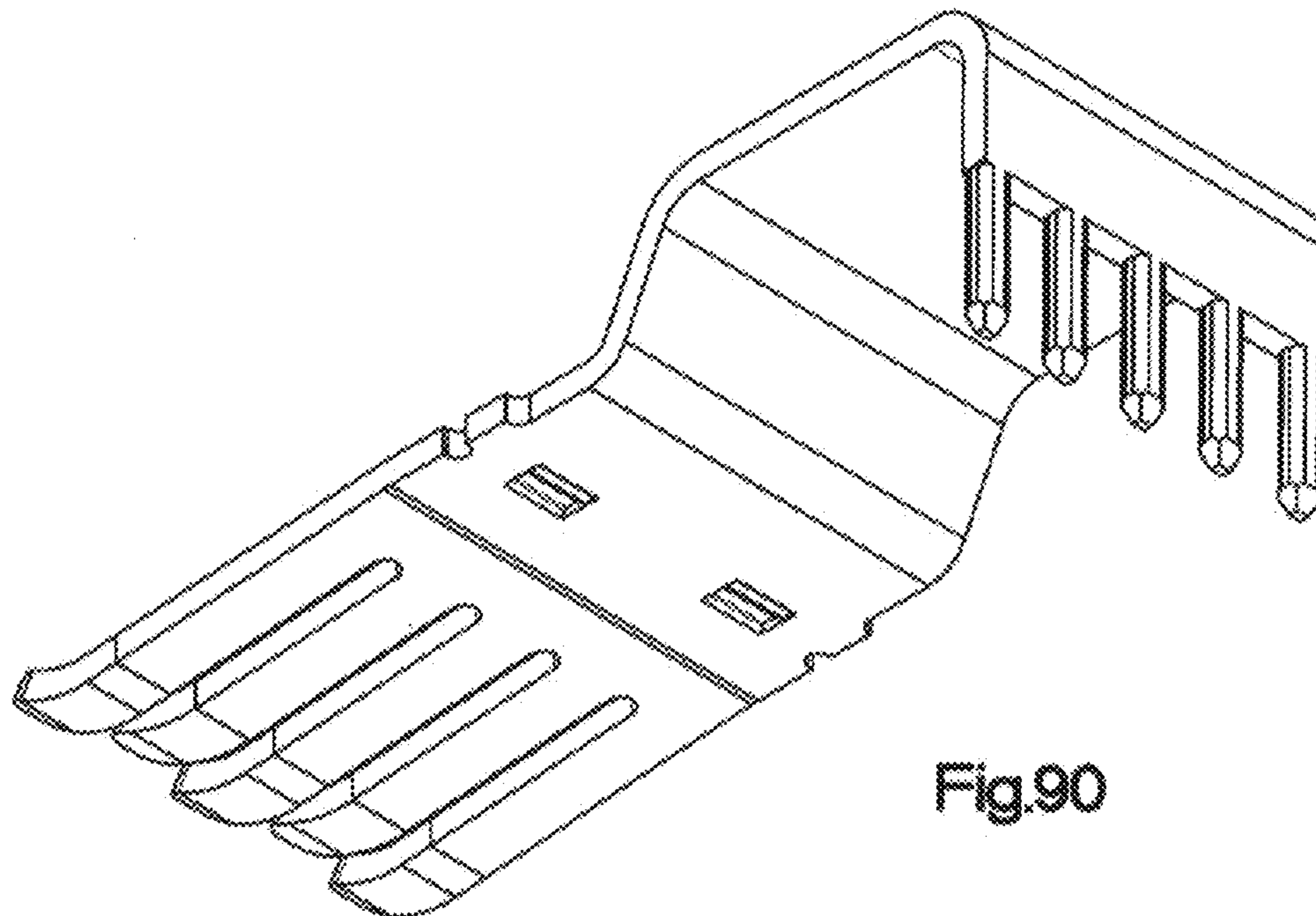
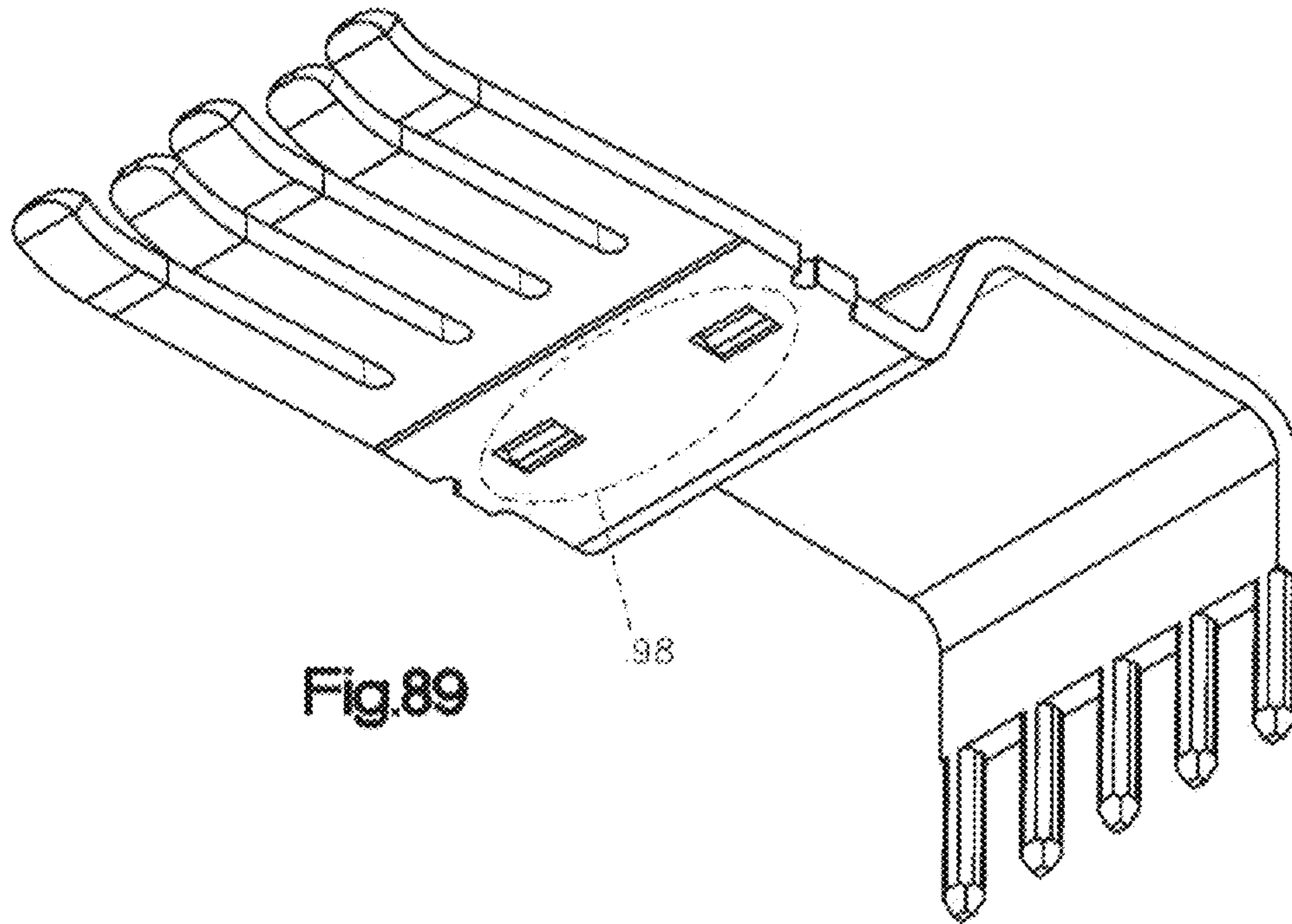

Fig.88



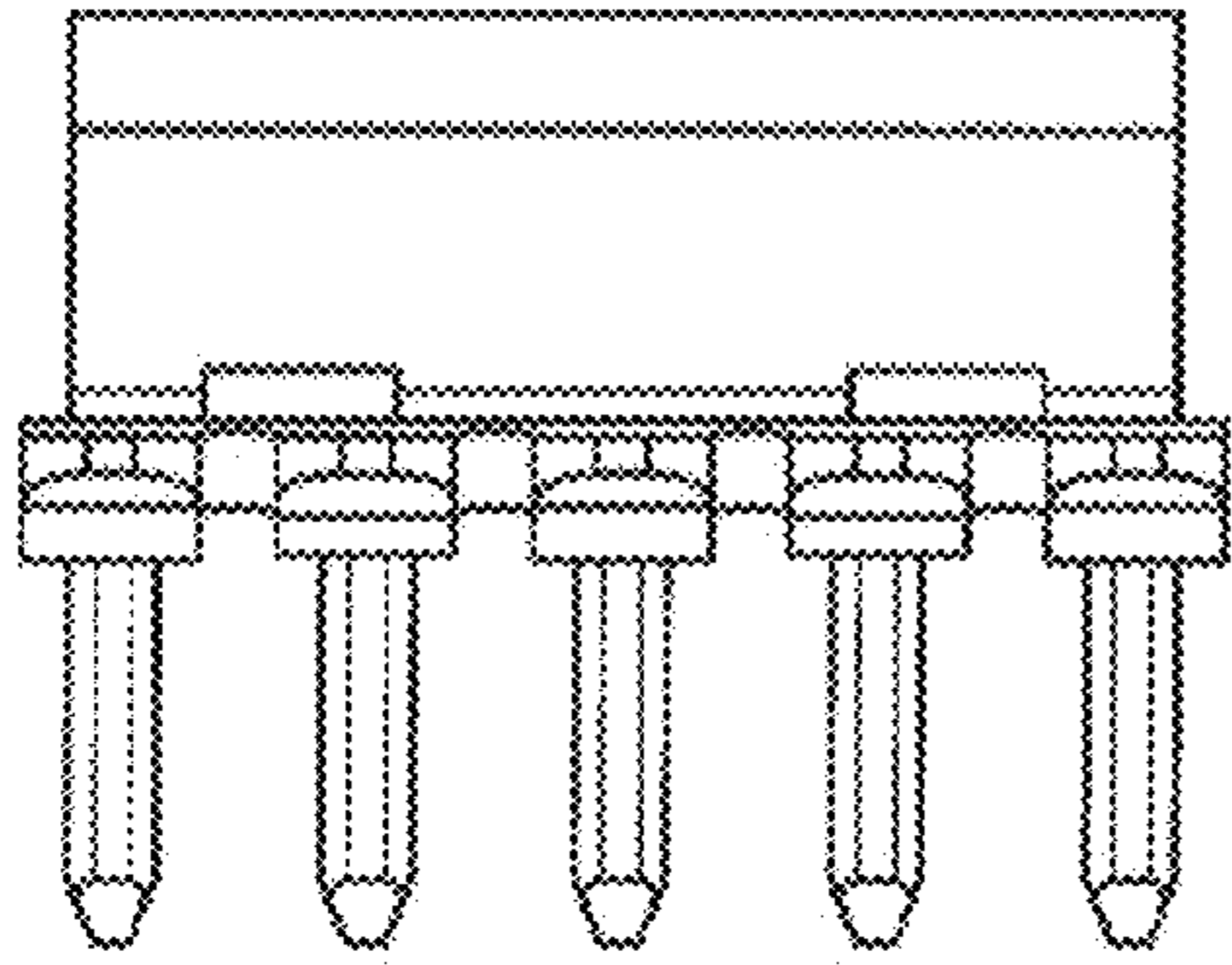

Fig.91

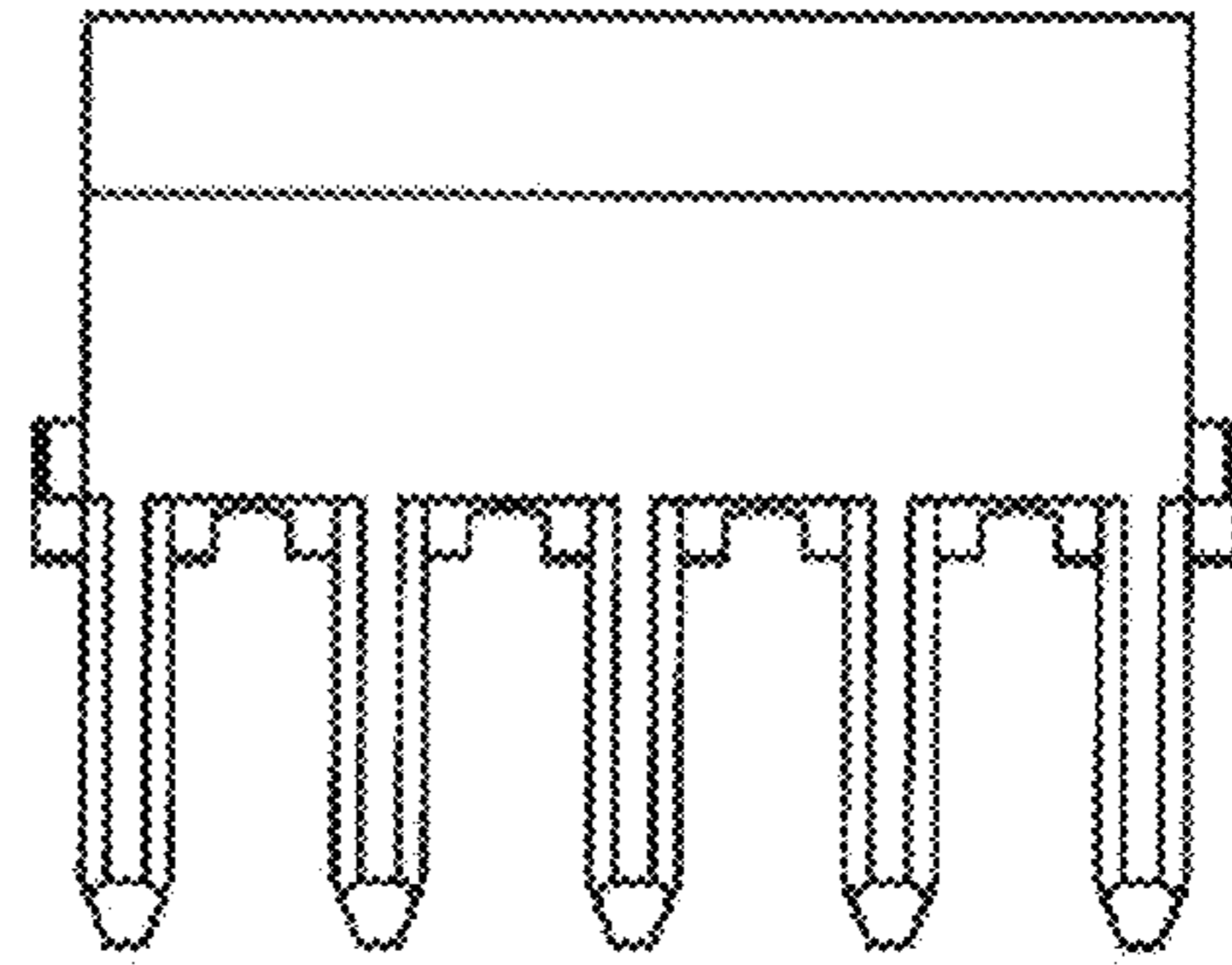

Fig.92

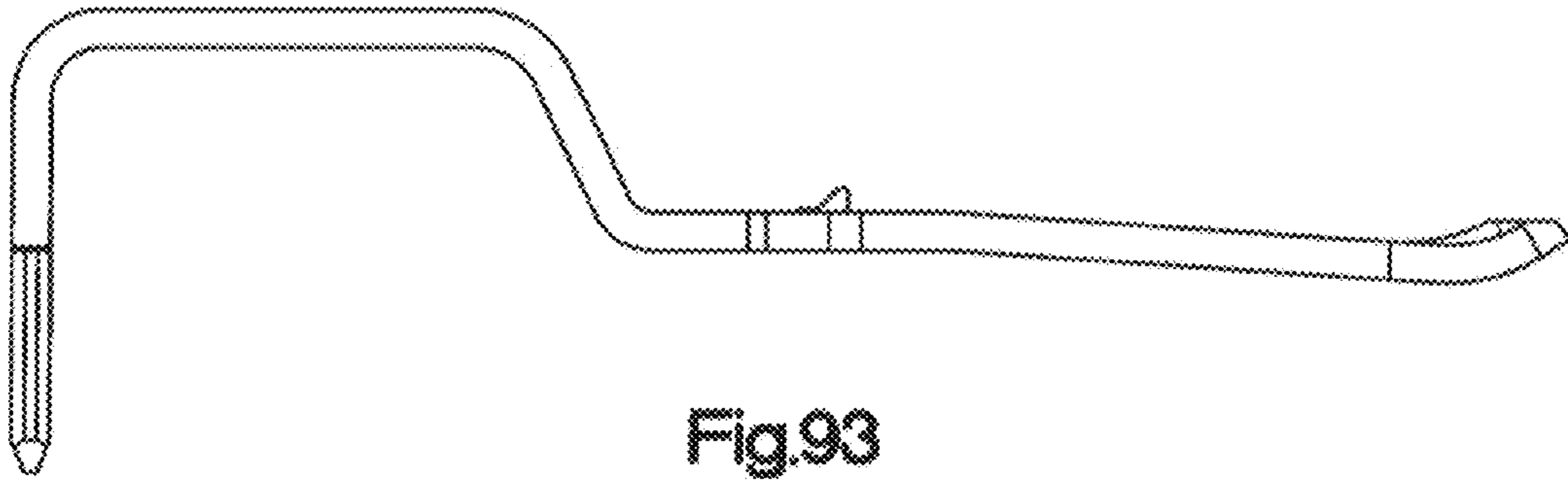

Fig.93

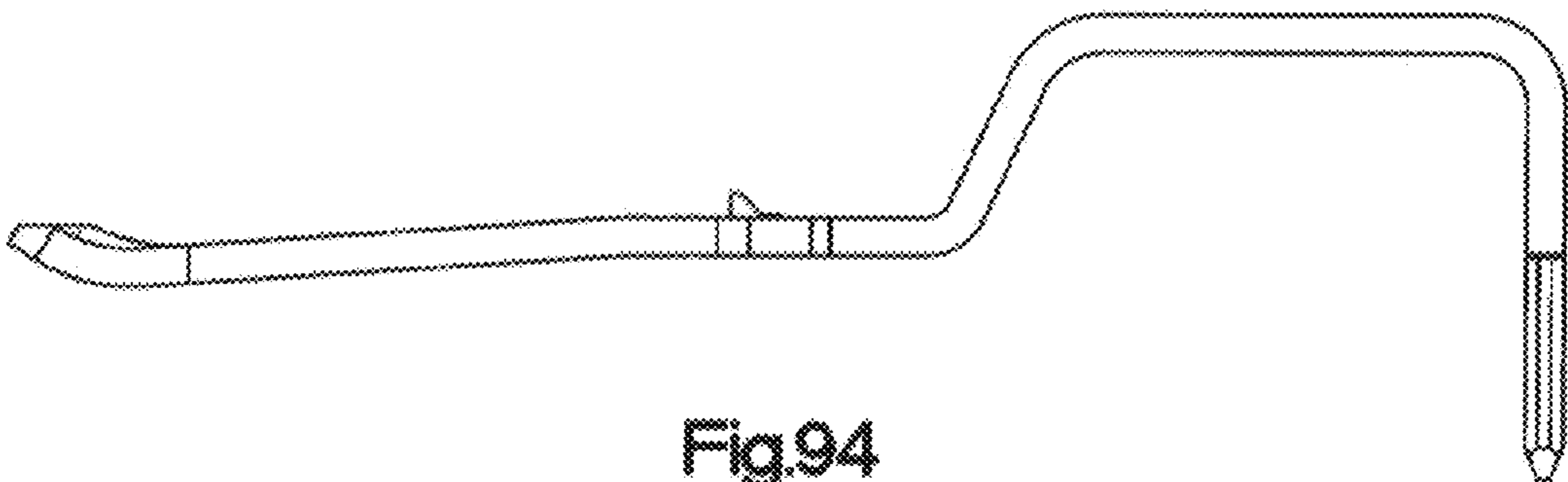

Fig.94

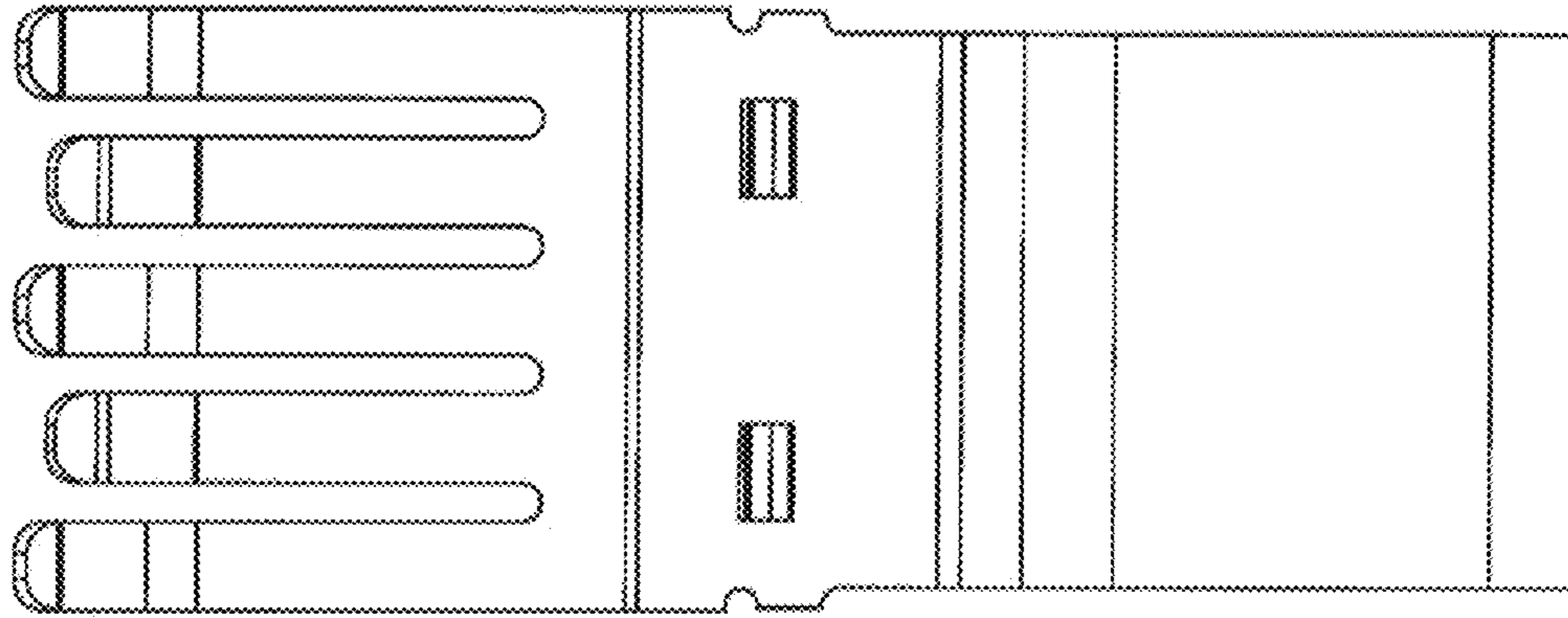

Fig.95

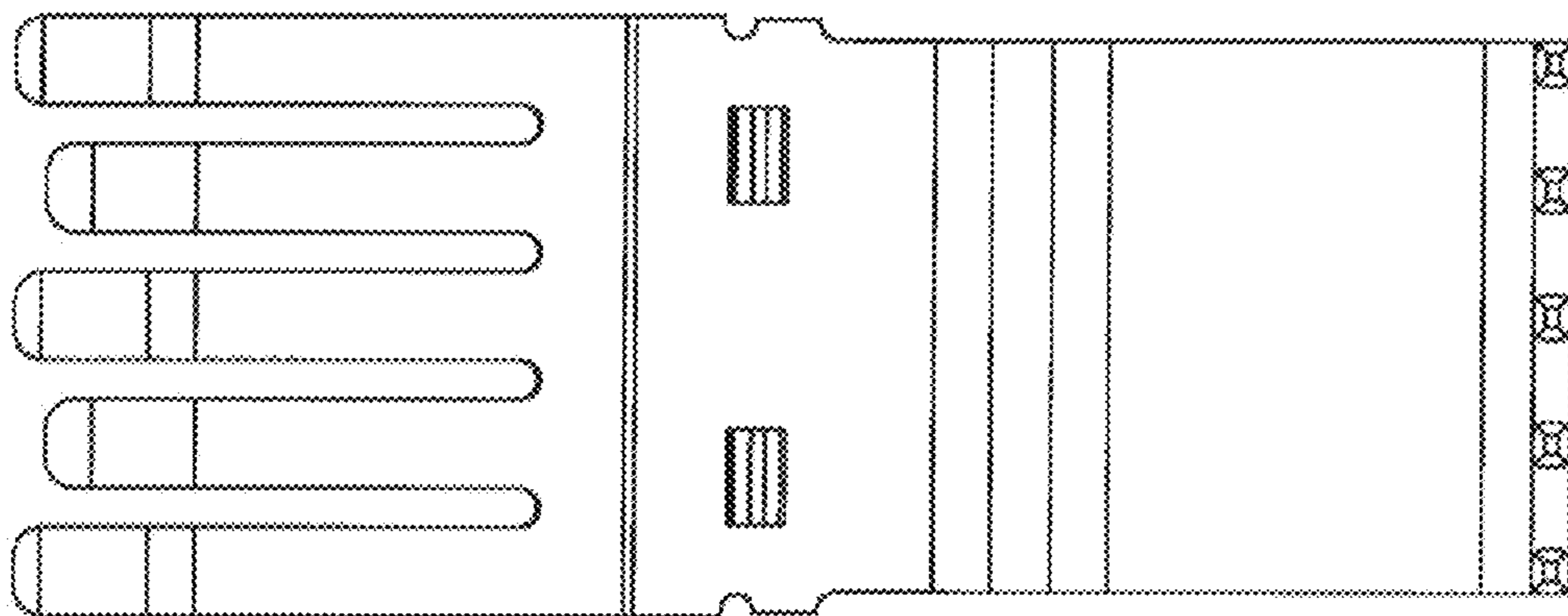

Fig.96

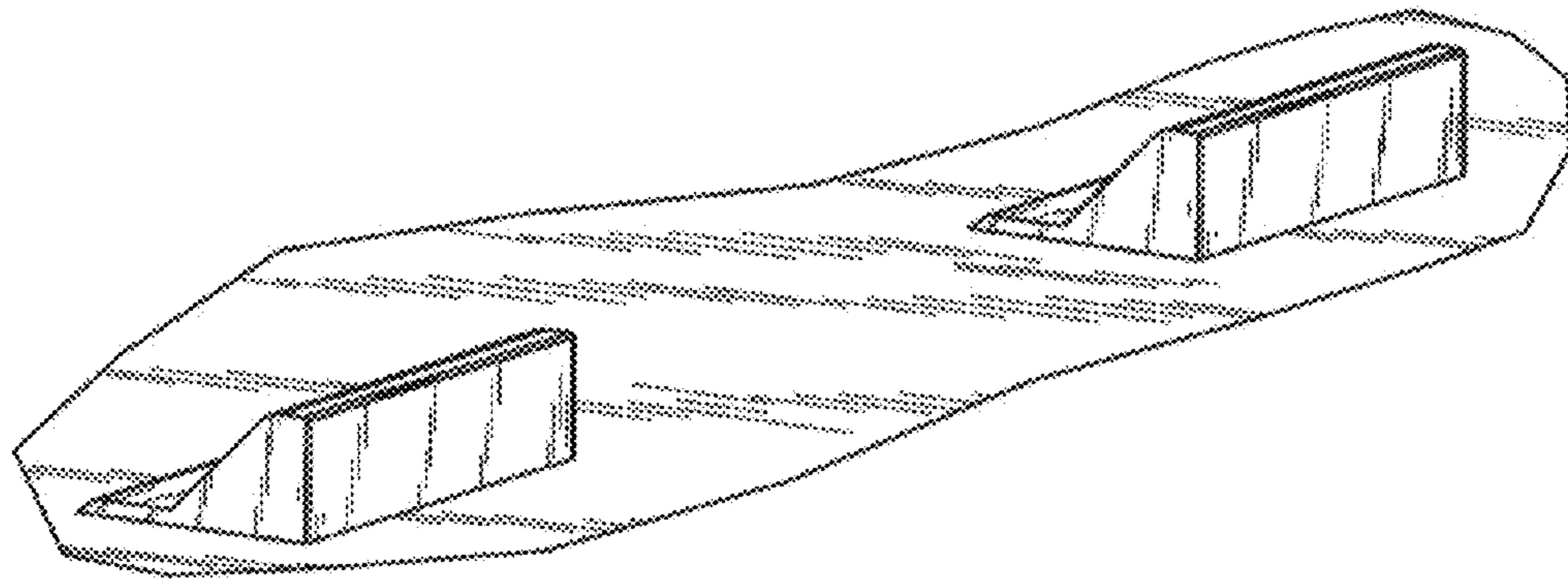

Fig.97

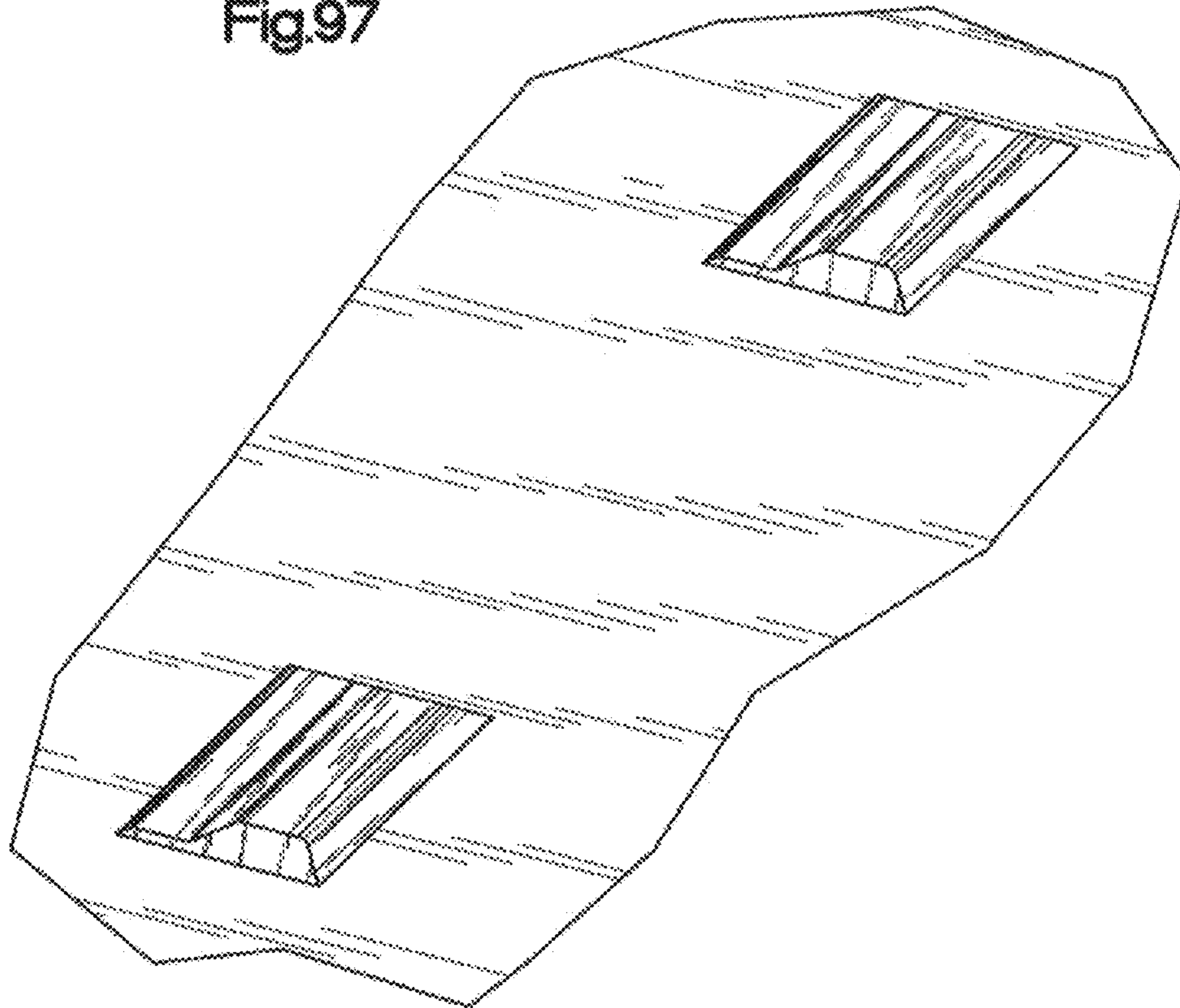

Fig.98

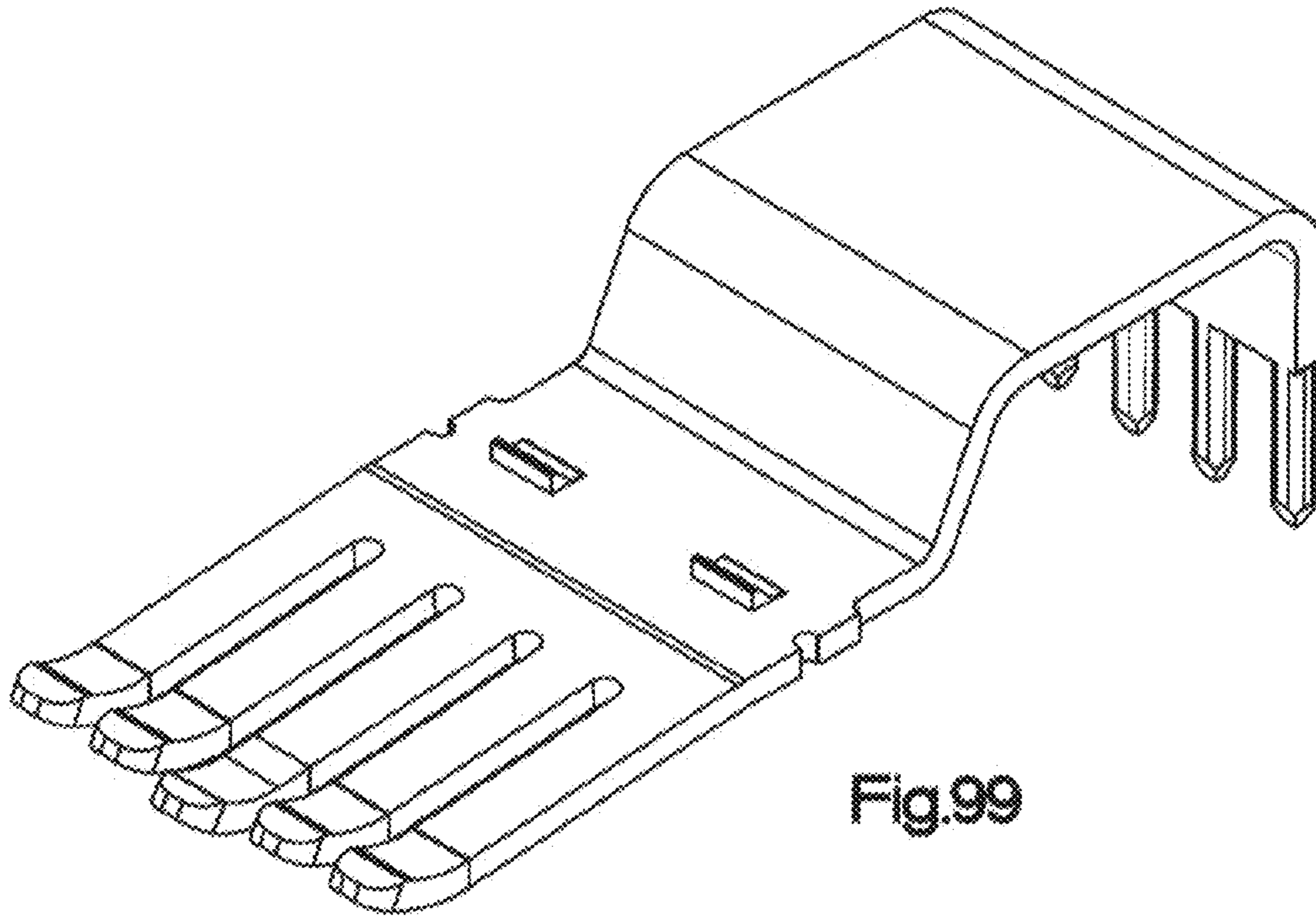

Fig.99

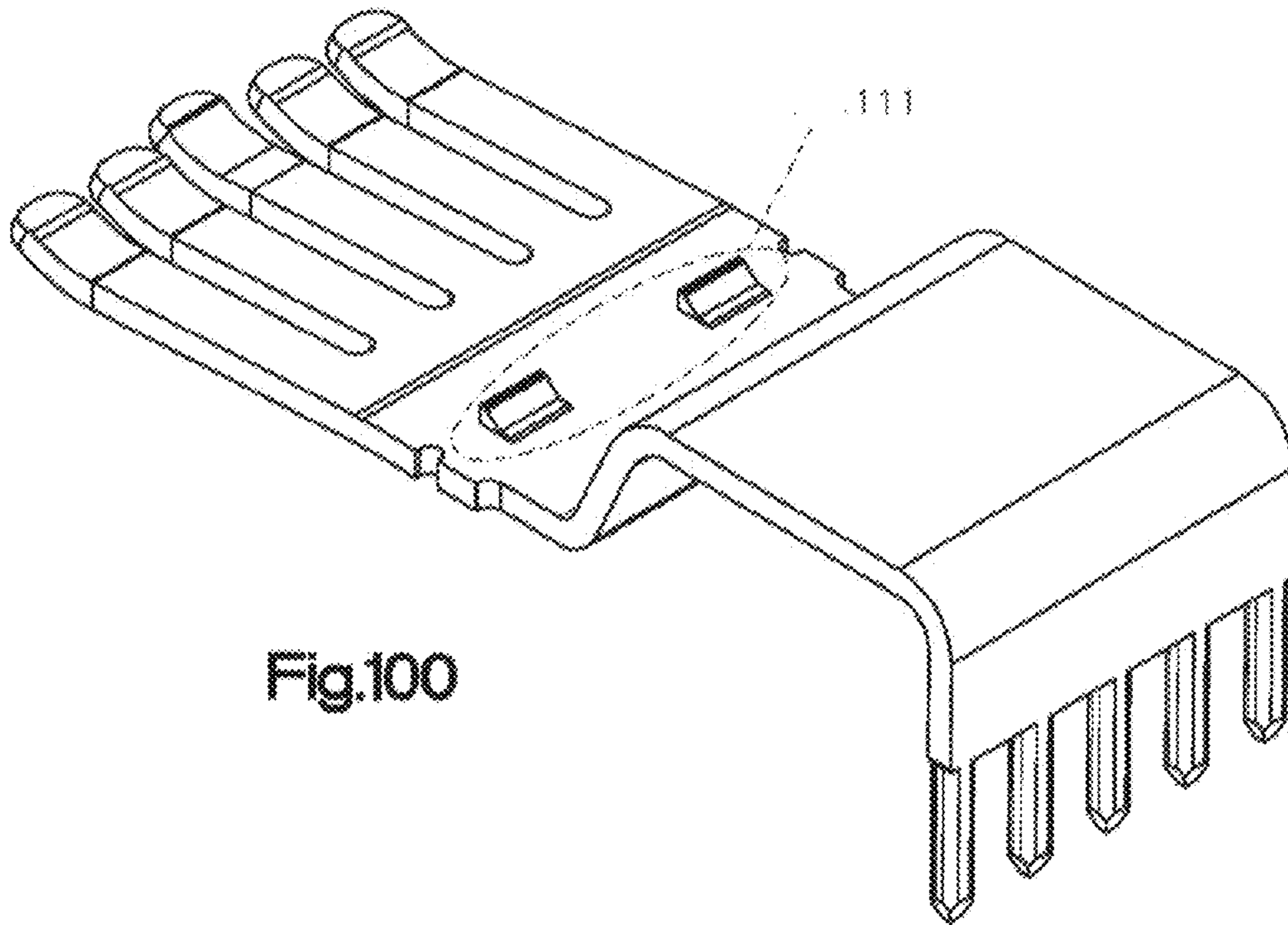

Fig.100

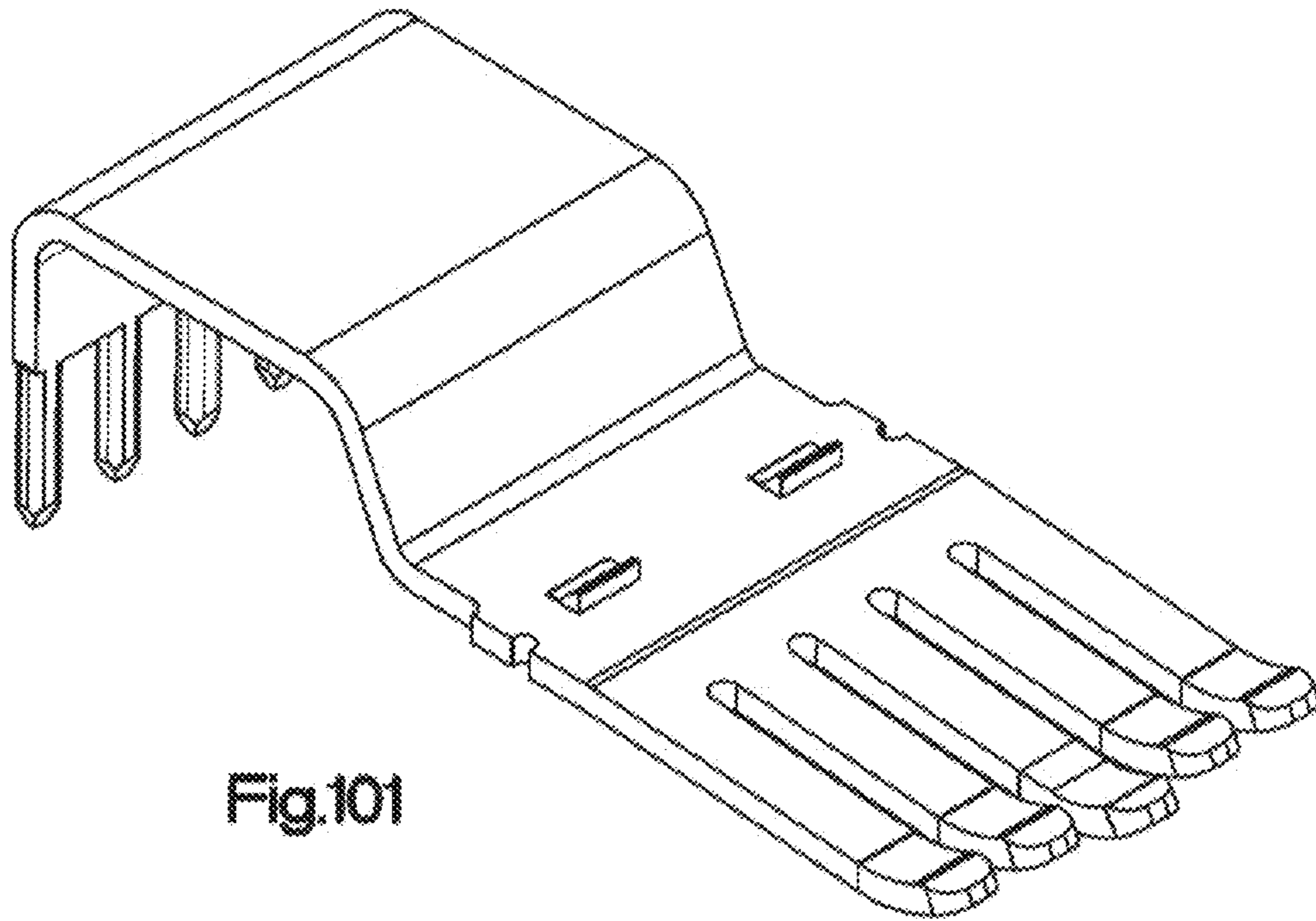

Fig.101

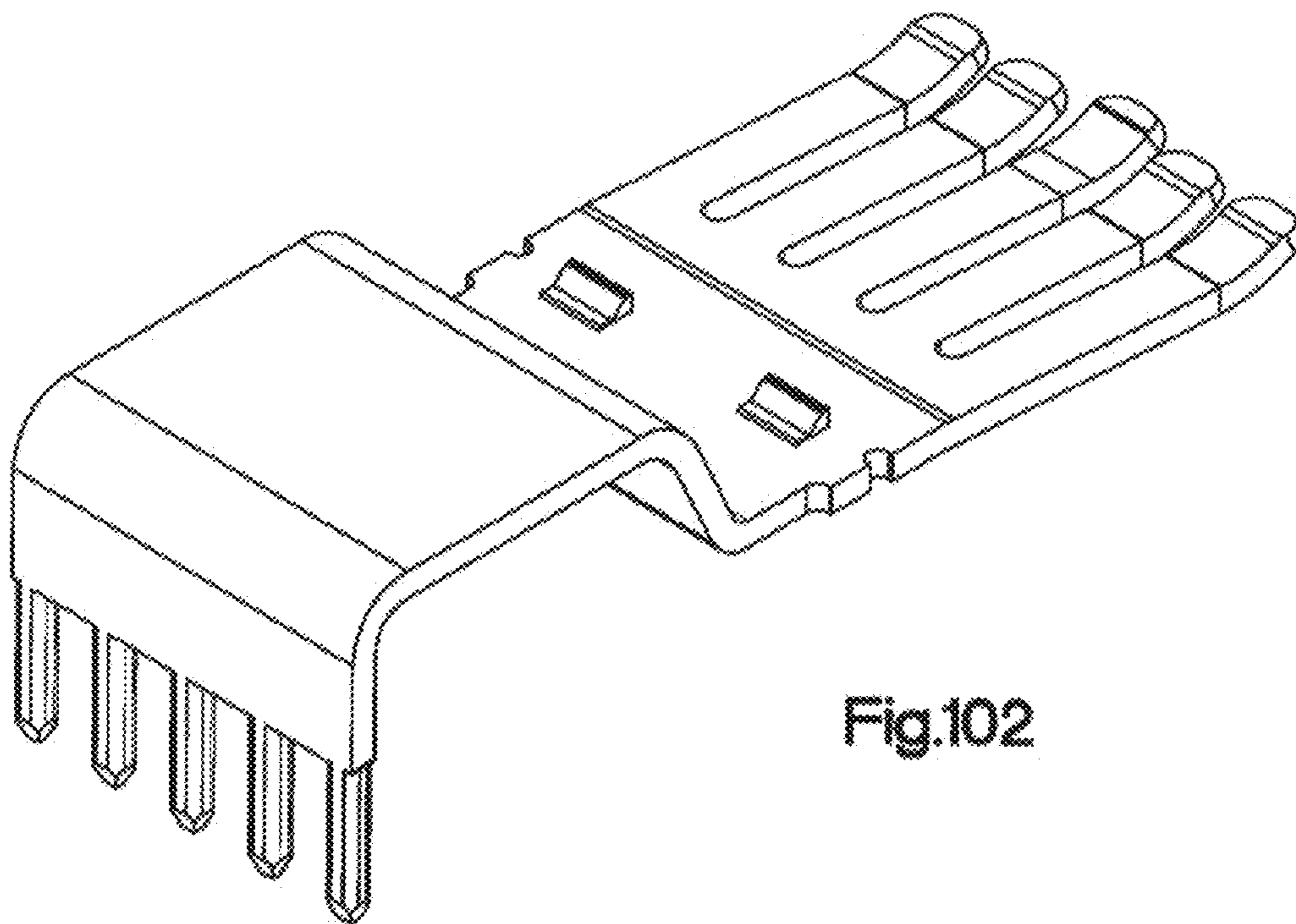
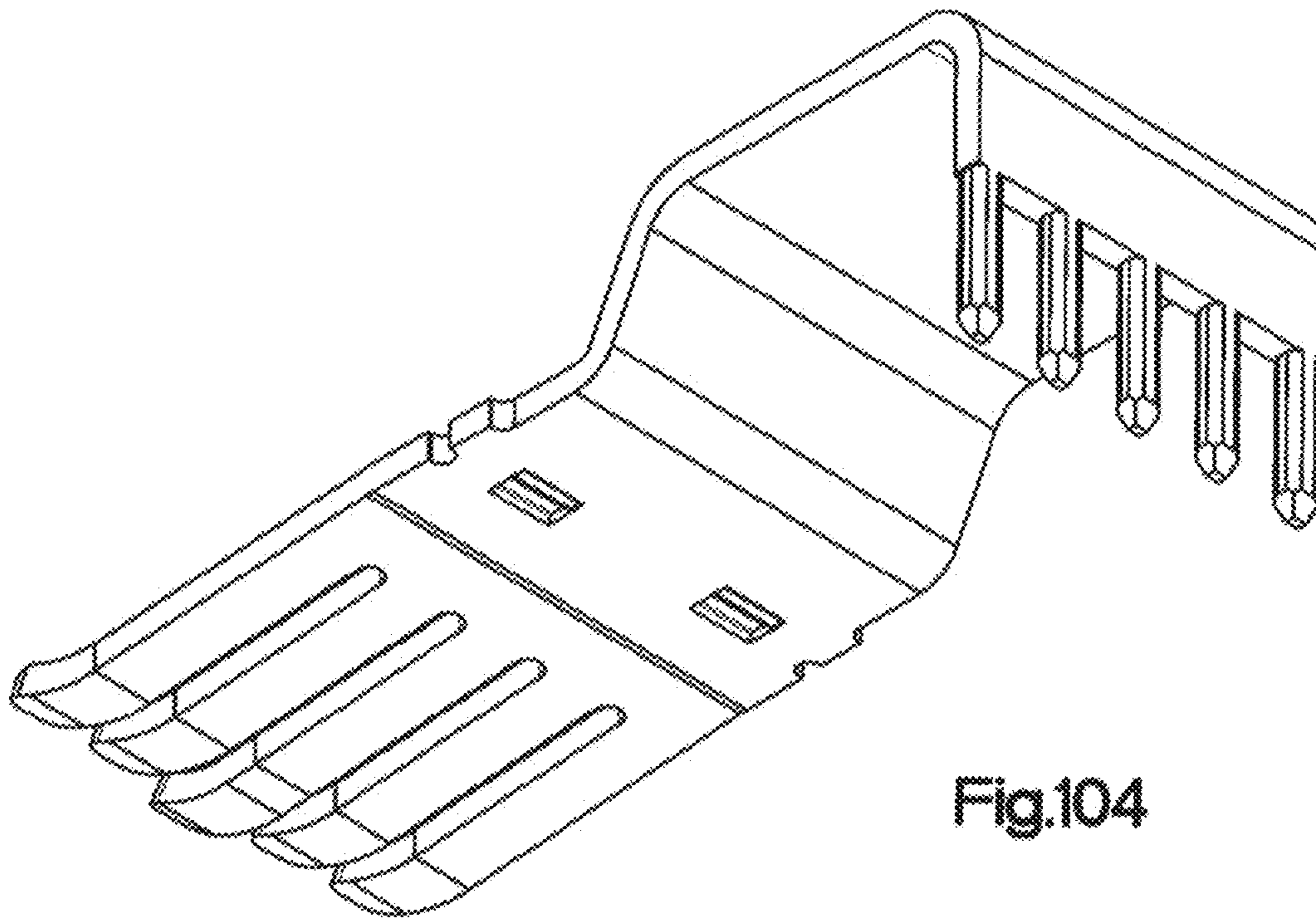
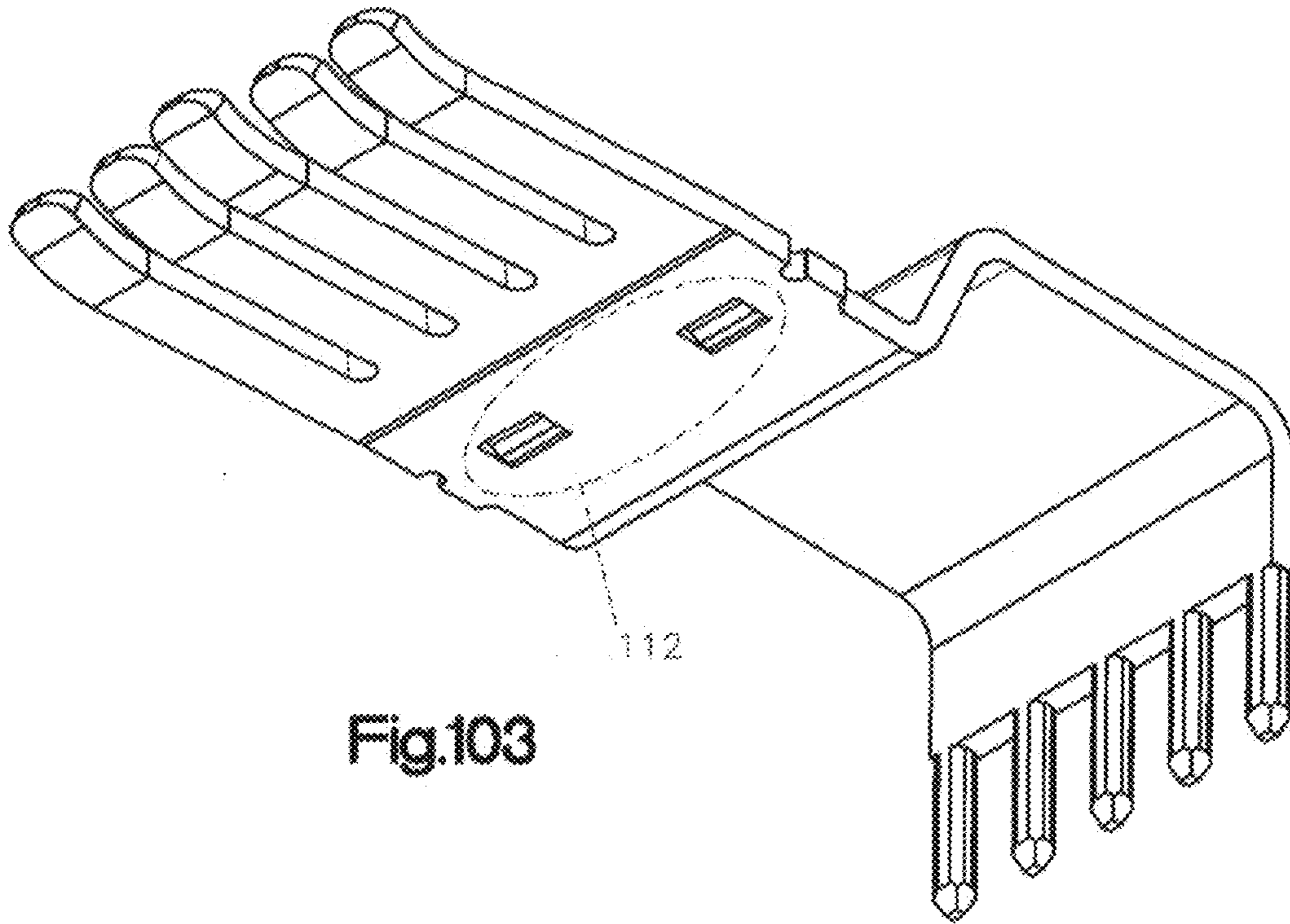

Fig.102



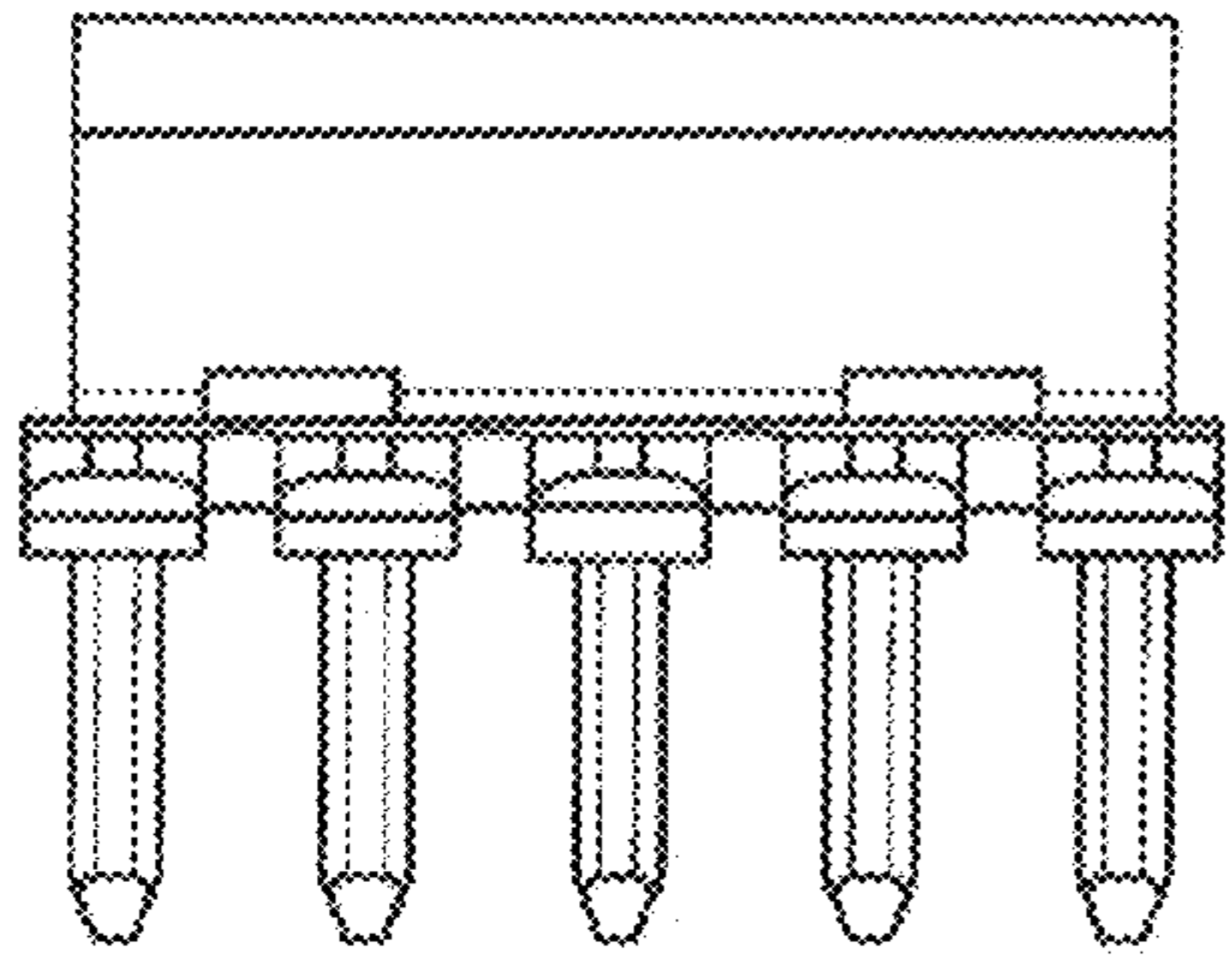

Fig.105

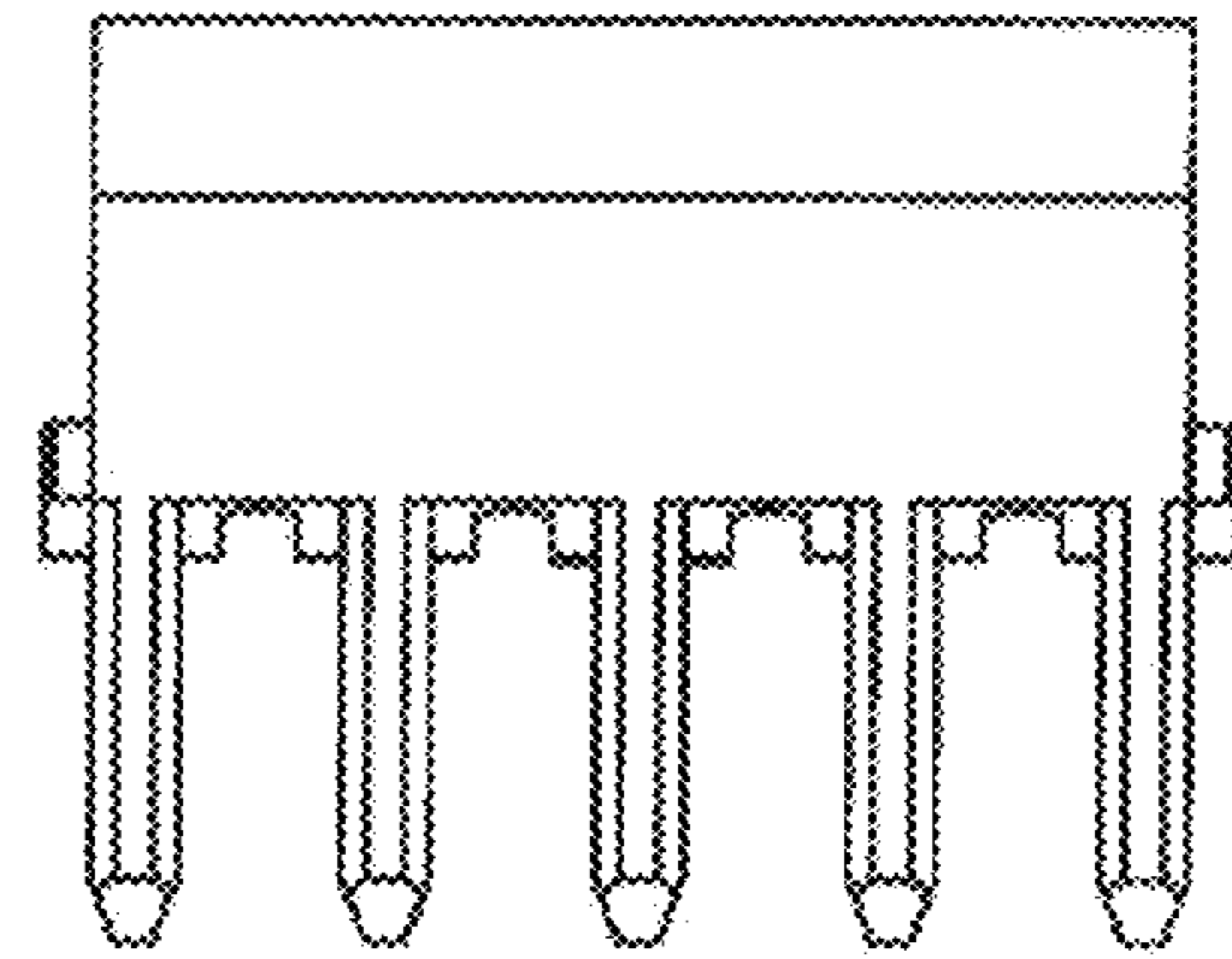

Fig.106

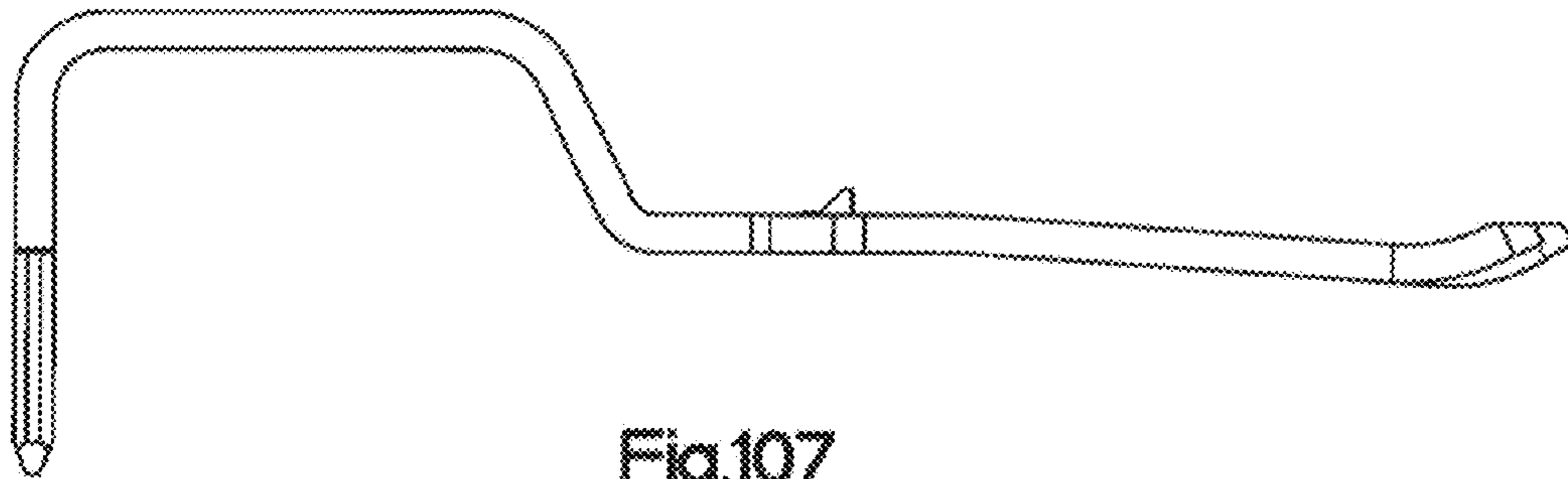

Fig.107

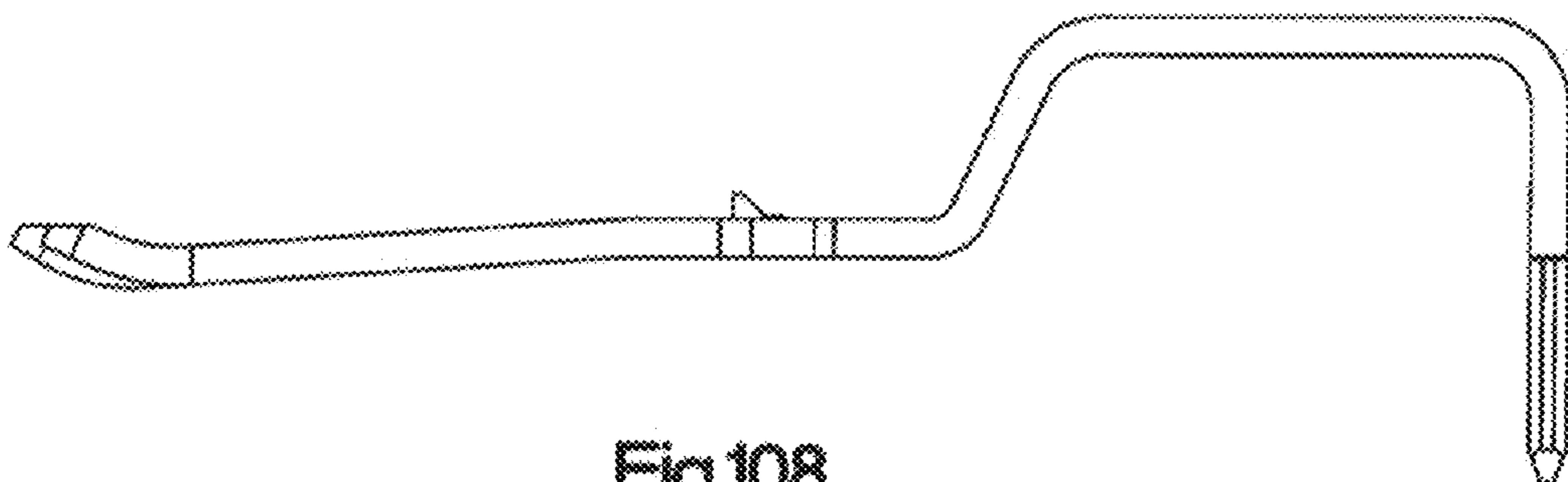

Fig.108

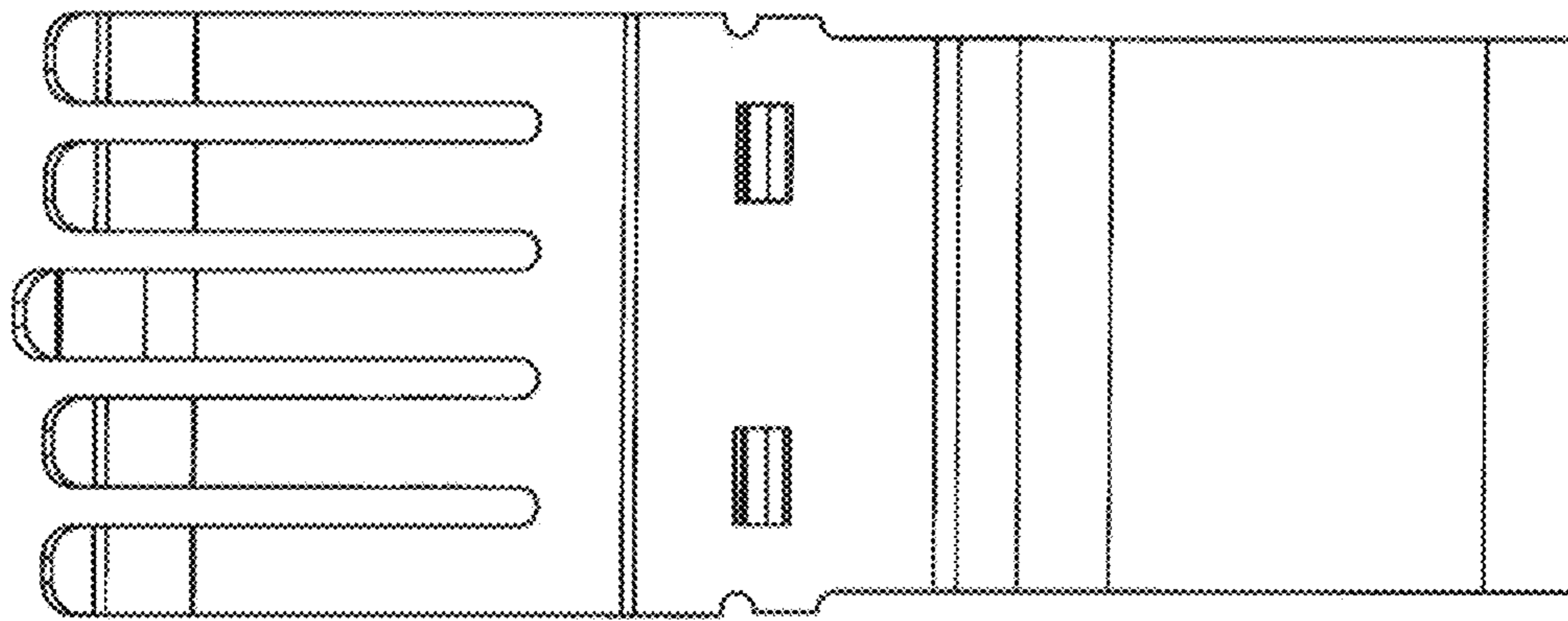

Fig.109

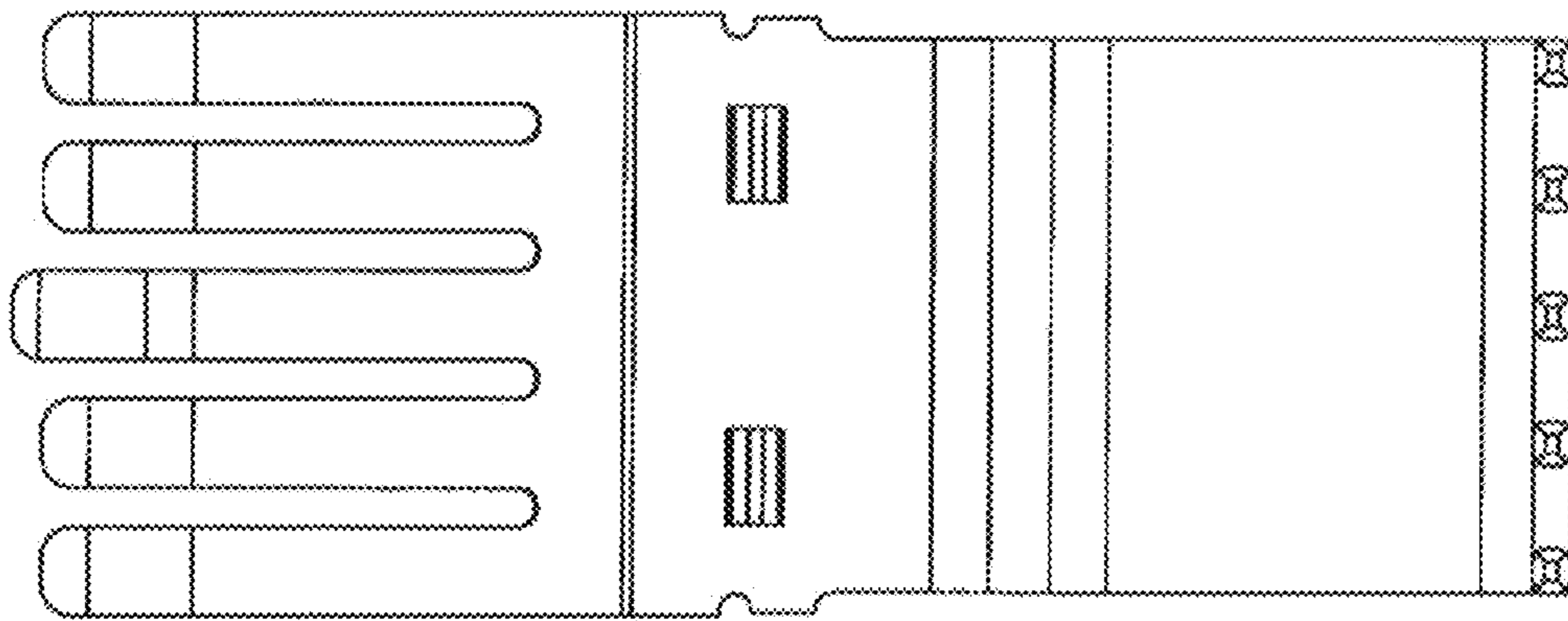

Fig.110

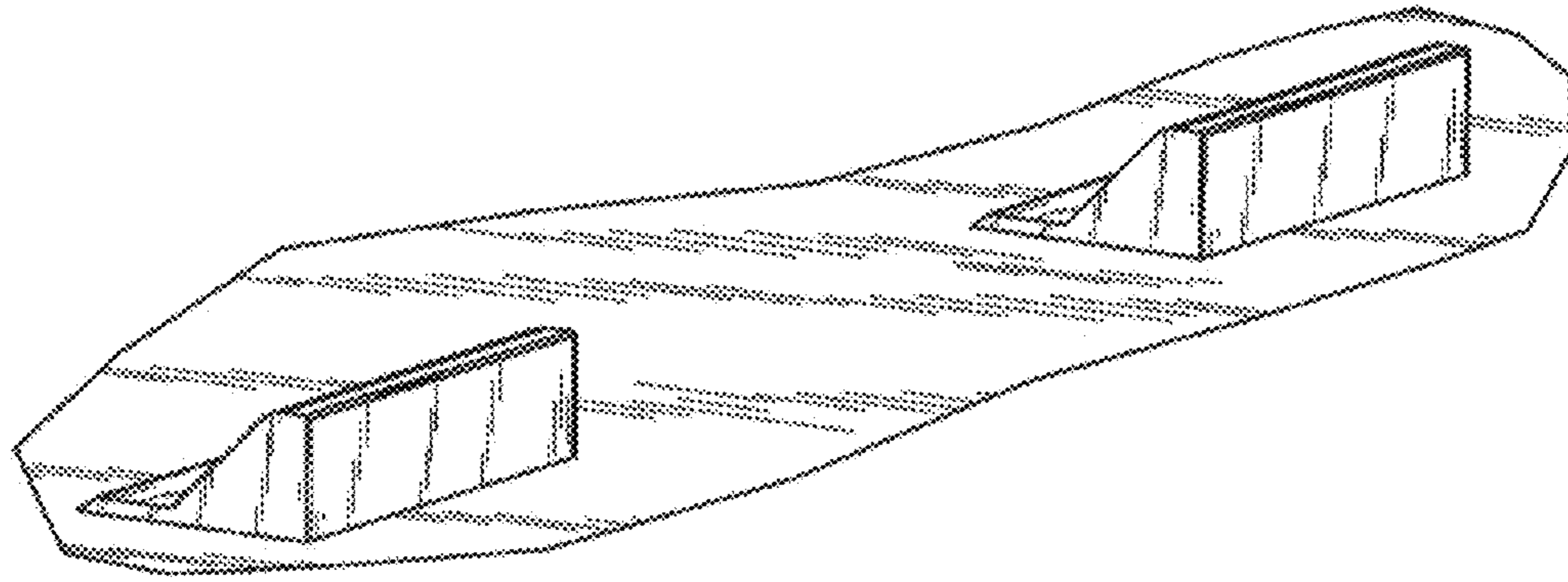

Fig.111

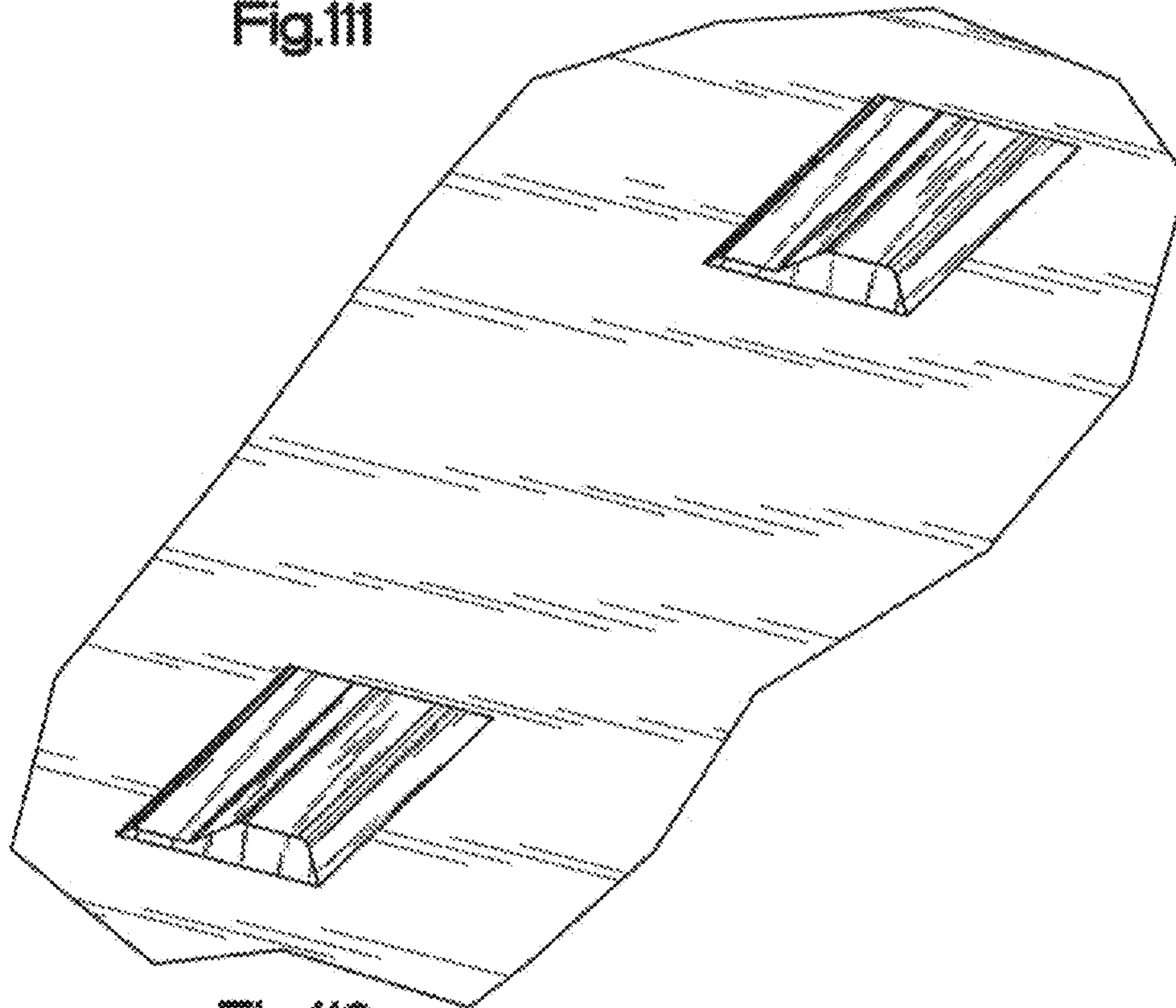

Fig.112

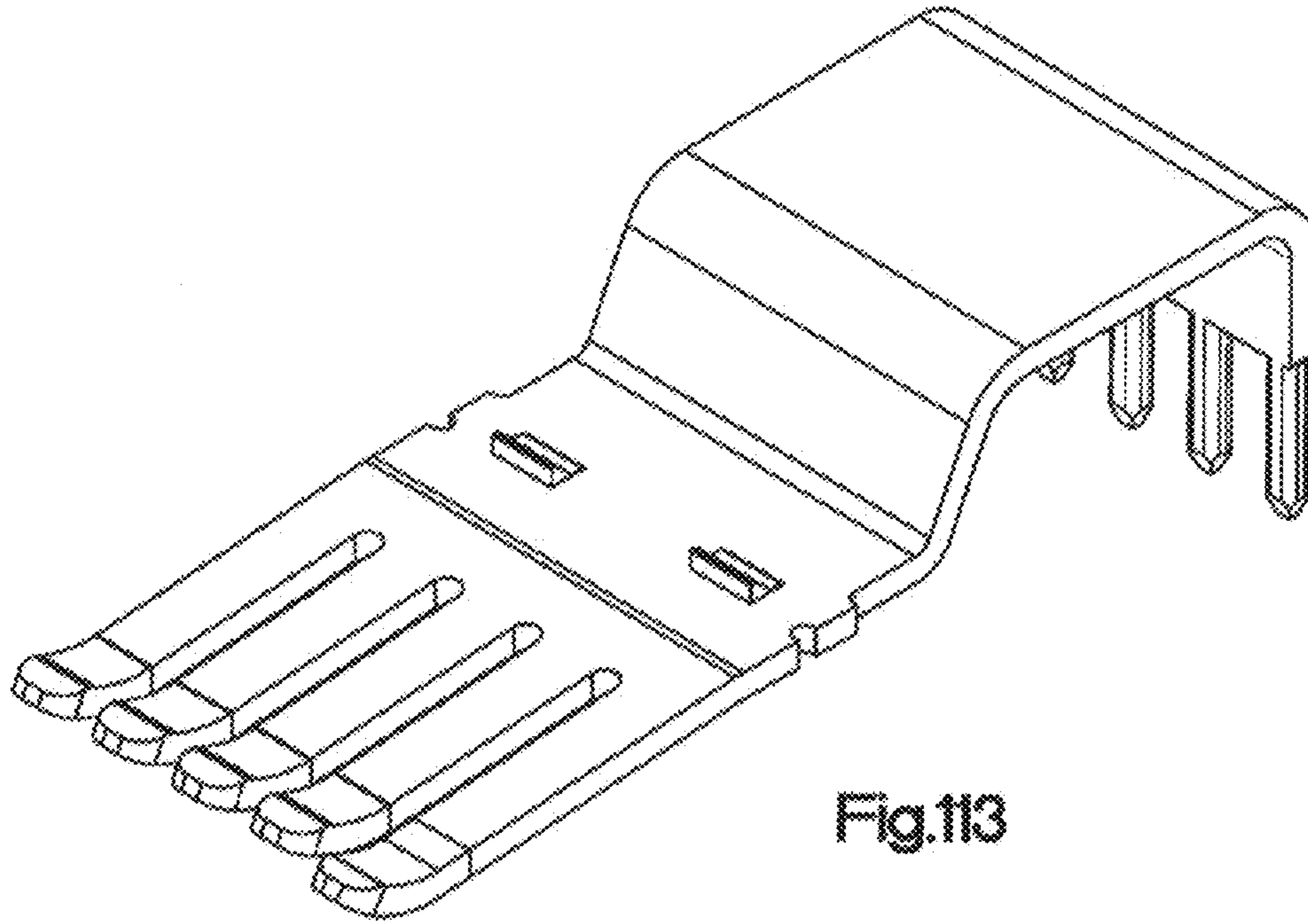

Fig.113

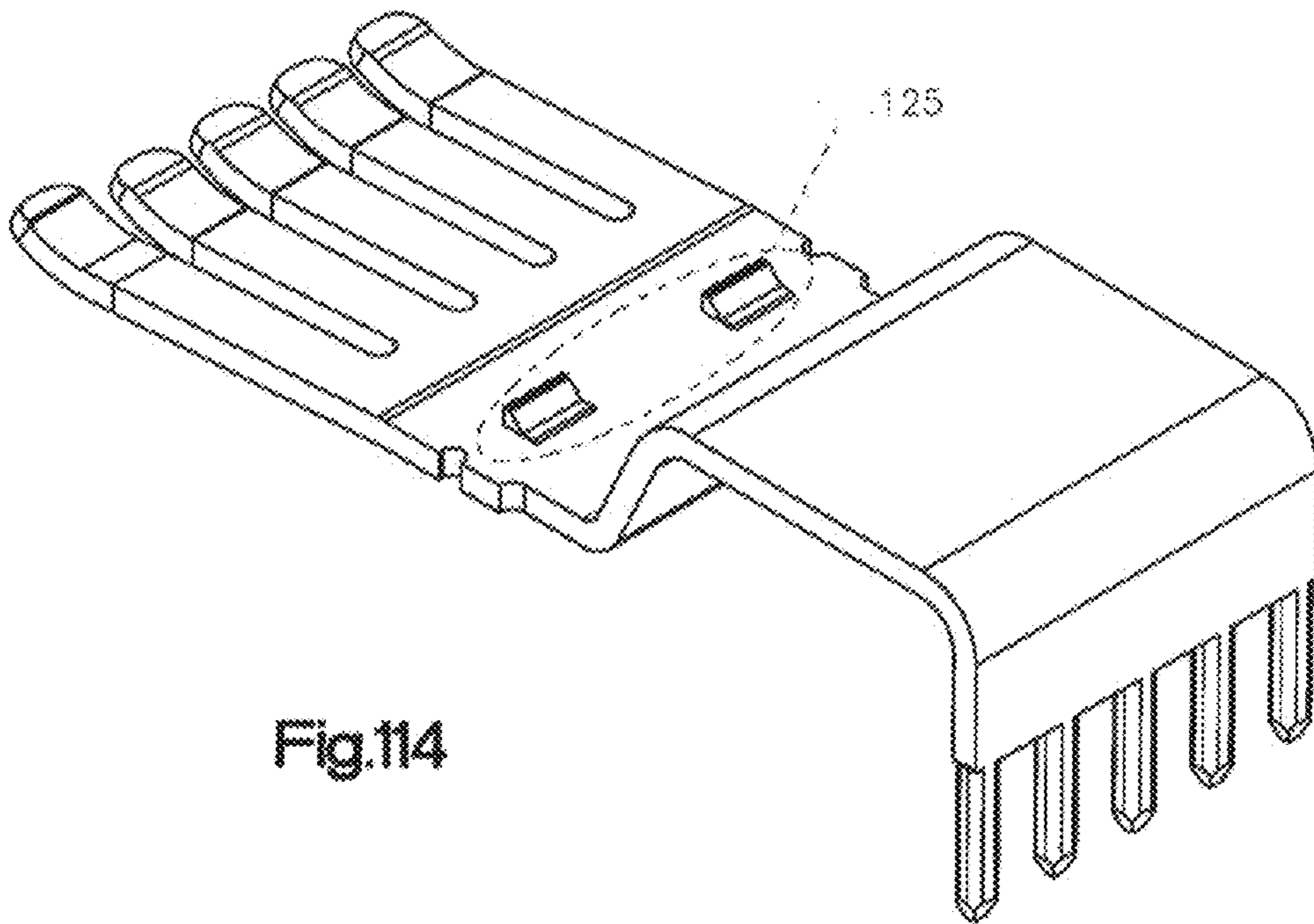
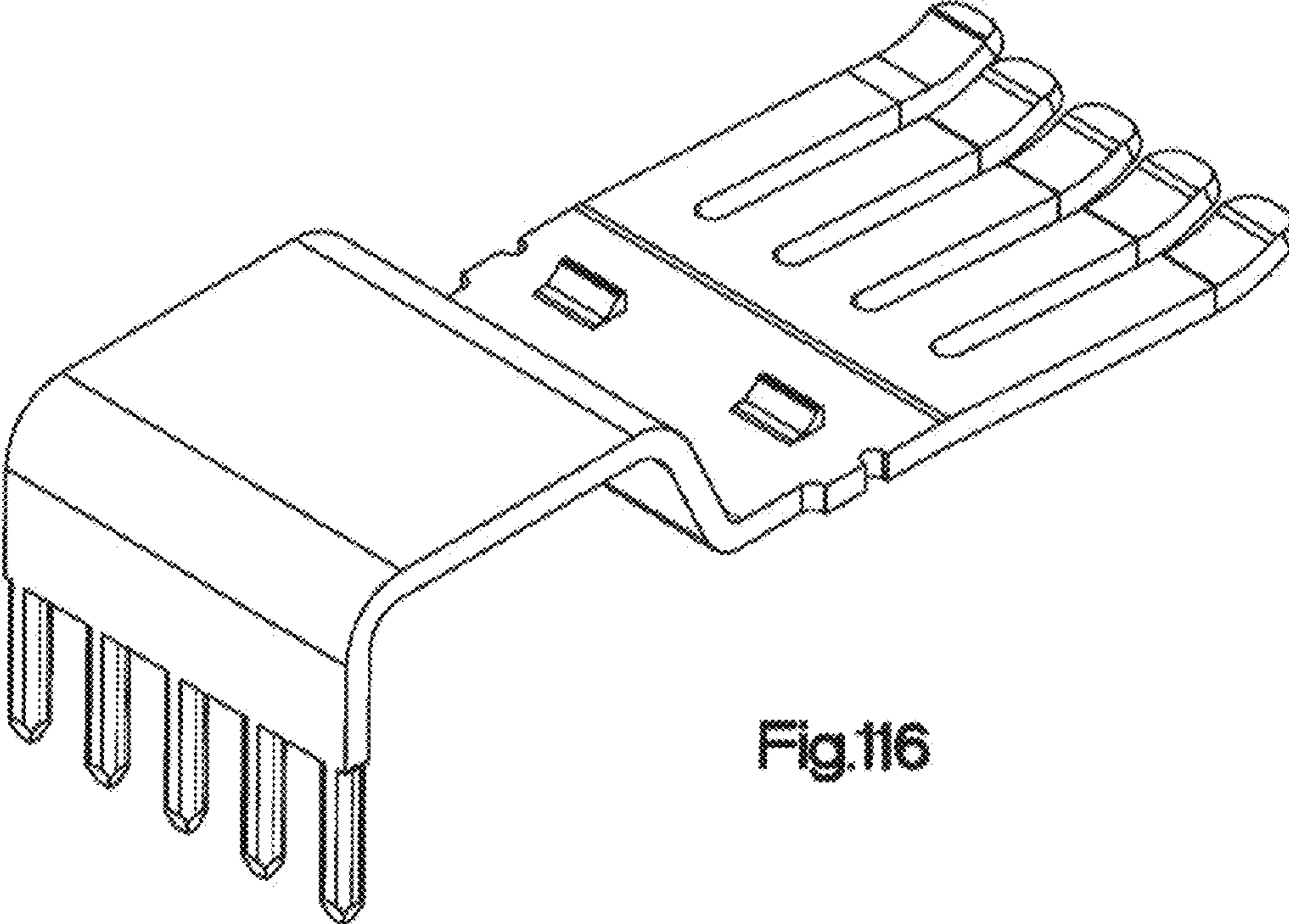
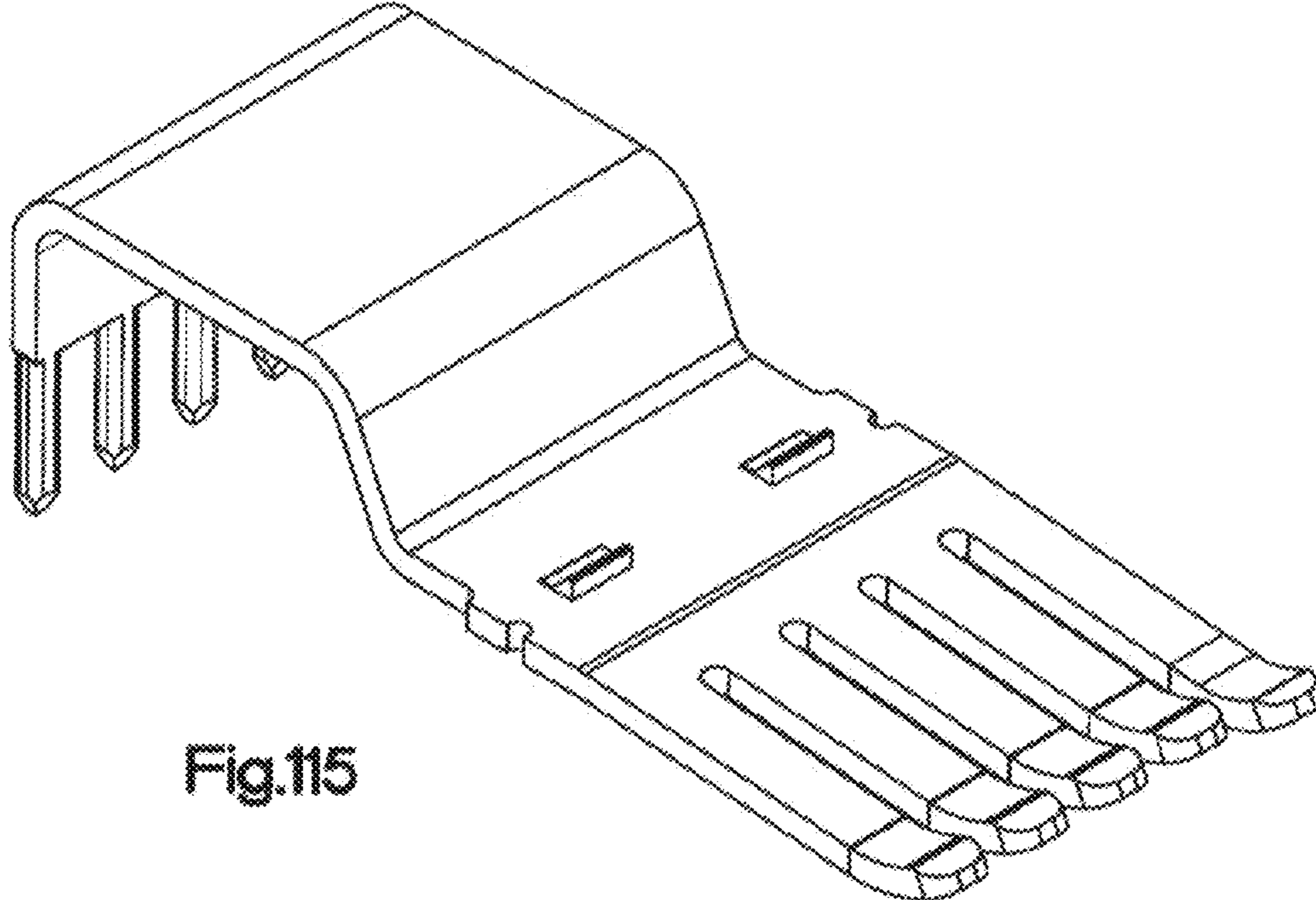

Fig.114



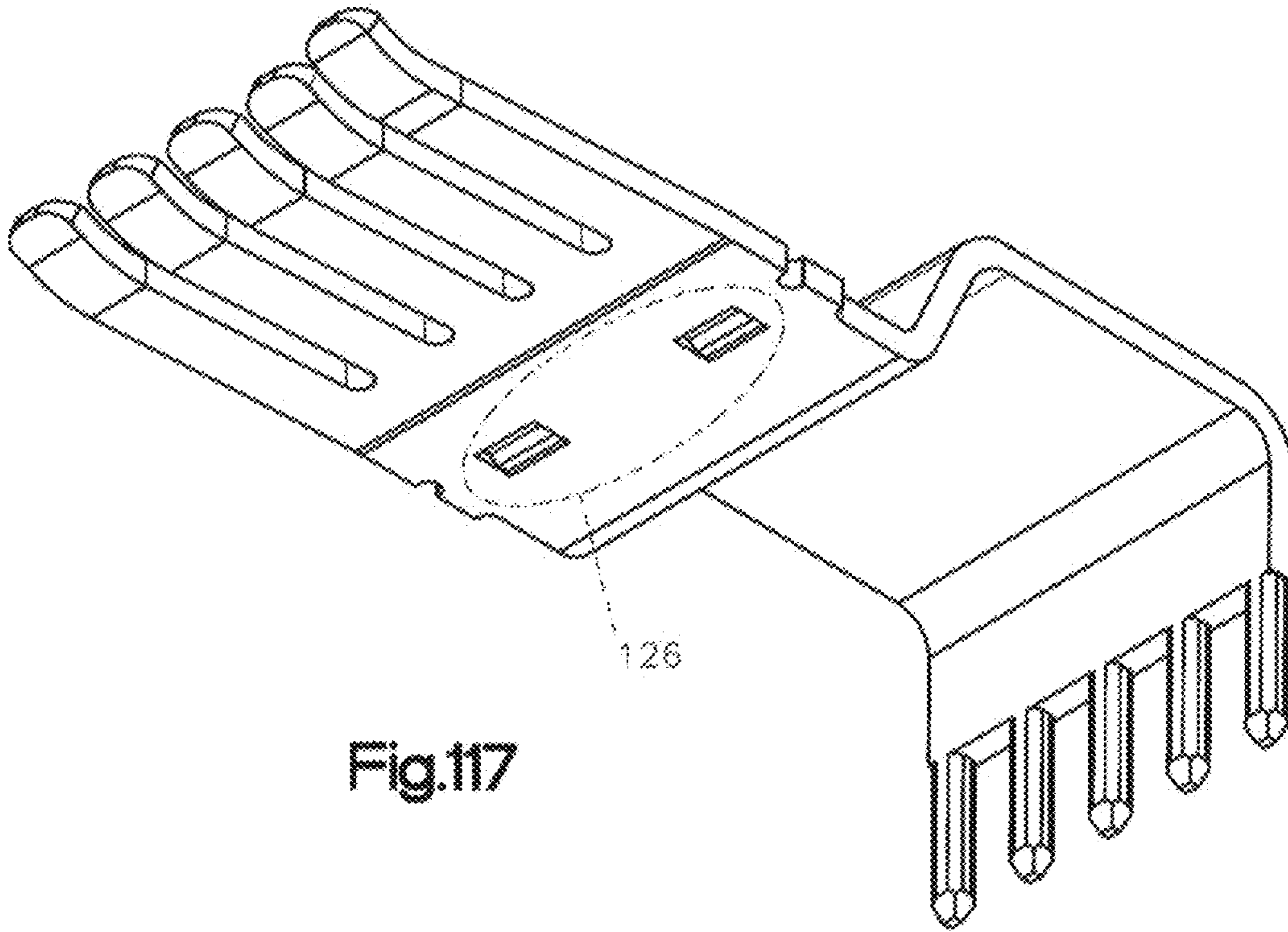

Fig.117

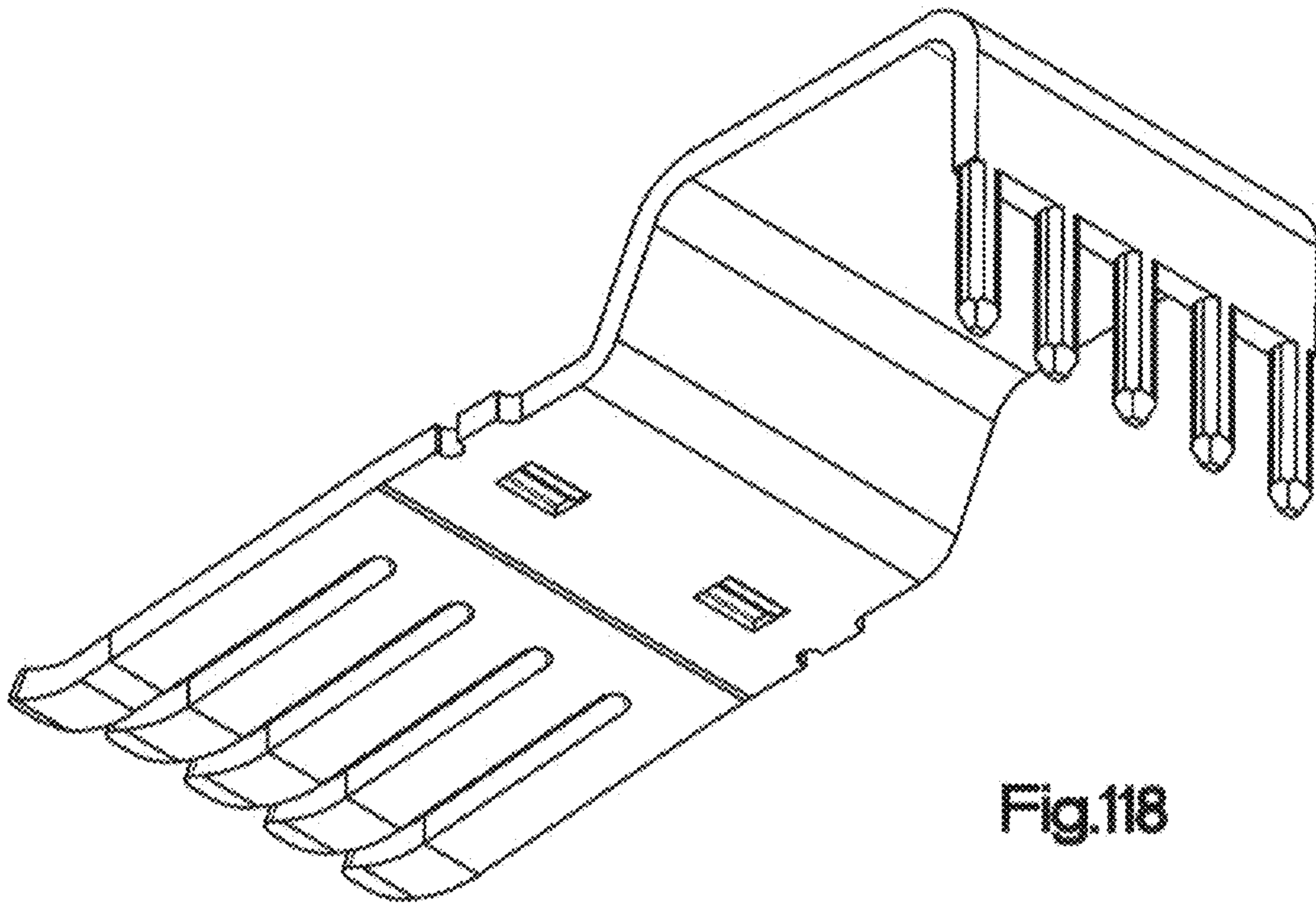

Fig.118

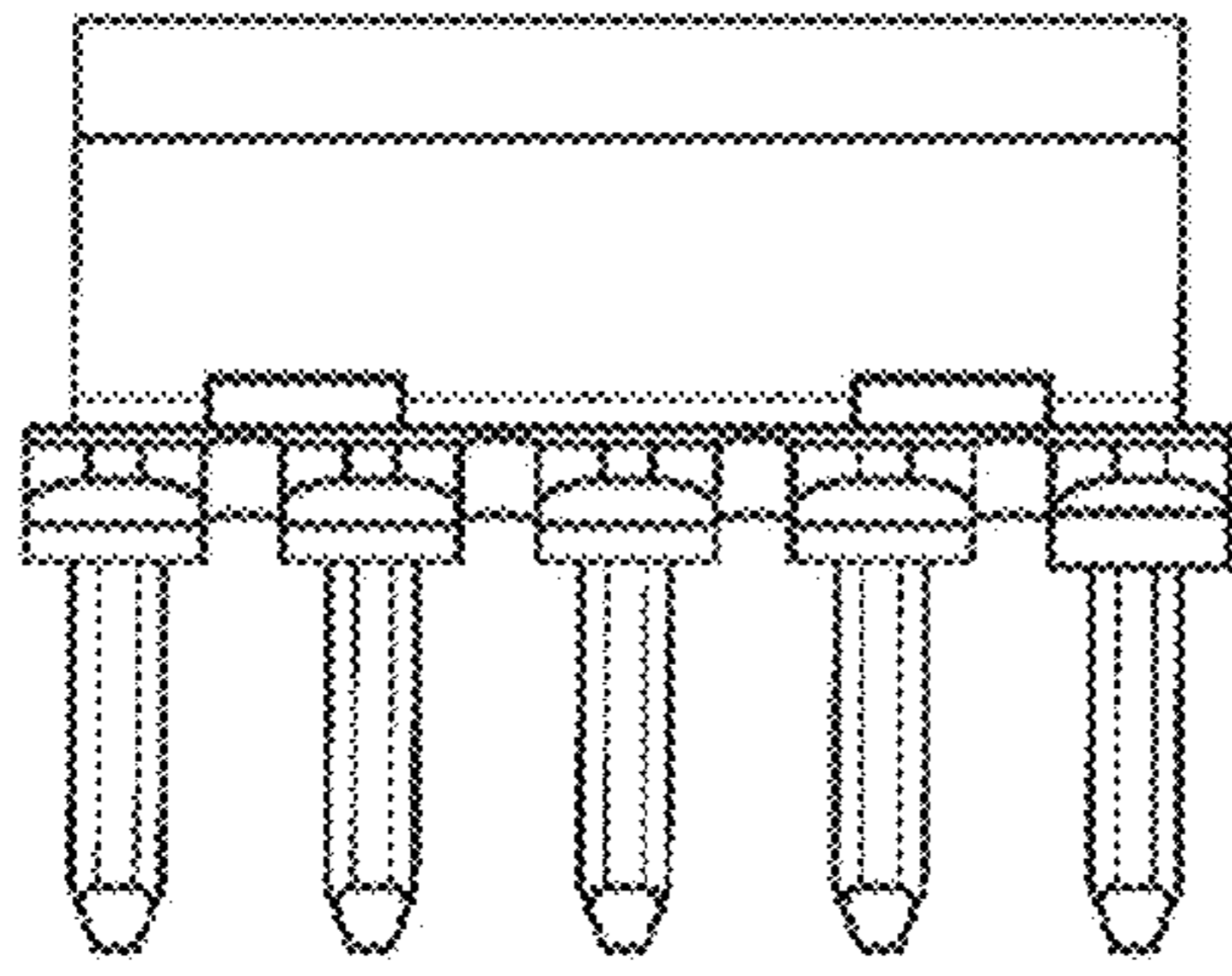

Fig.119

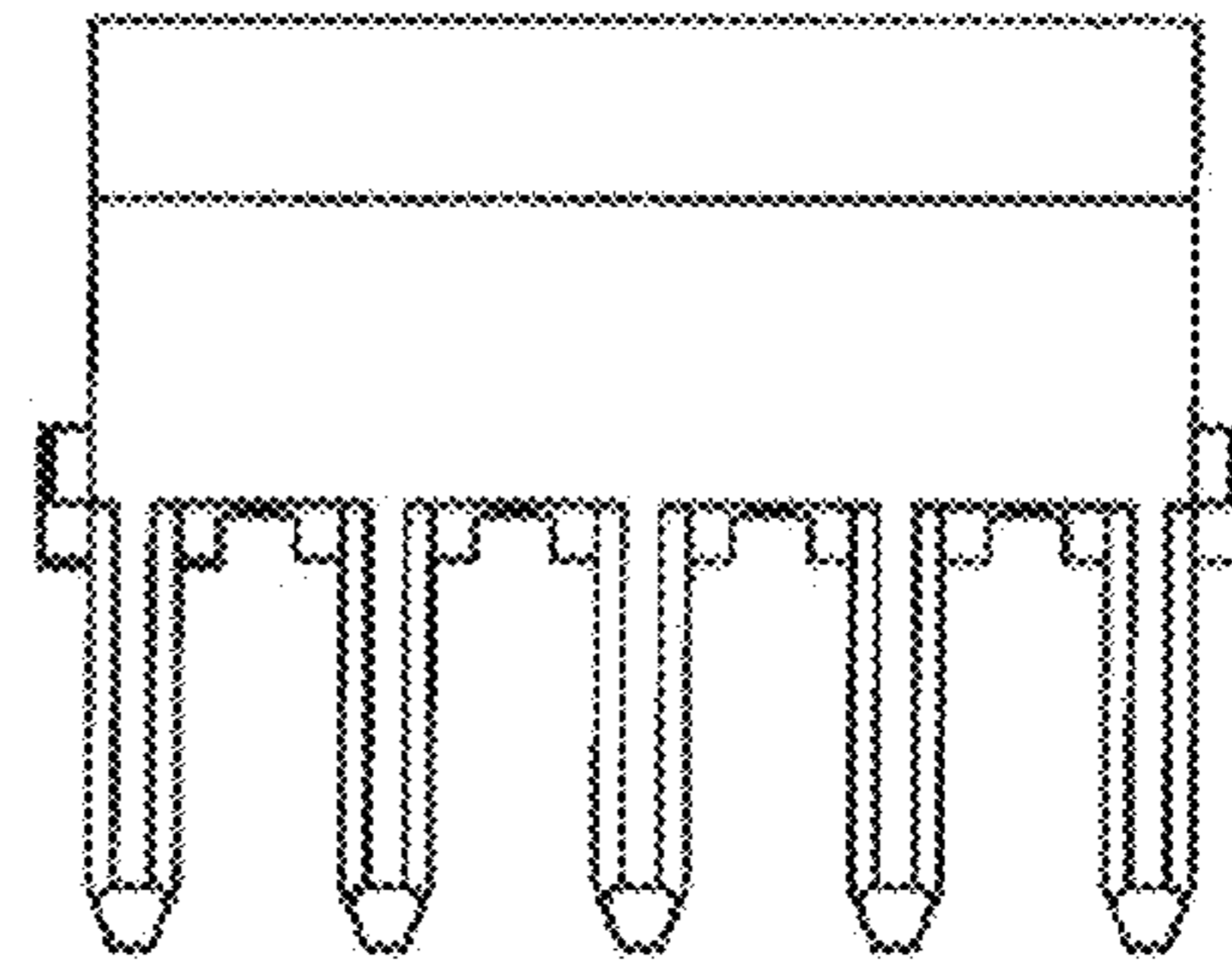

Fig.120

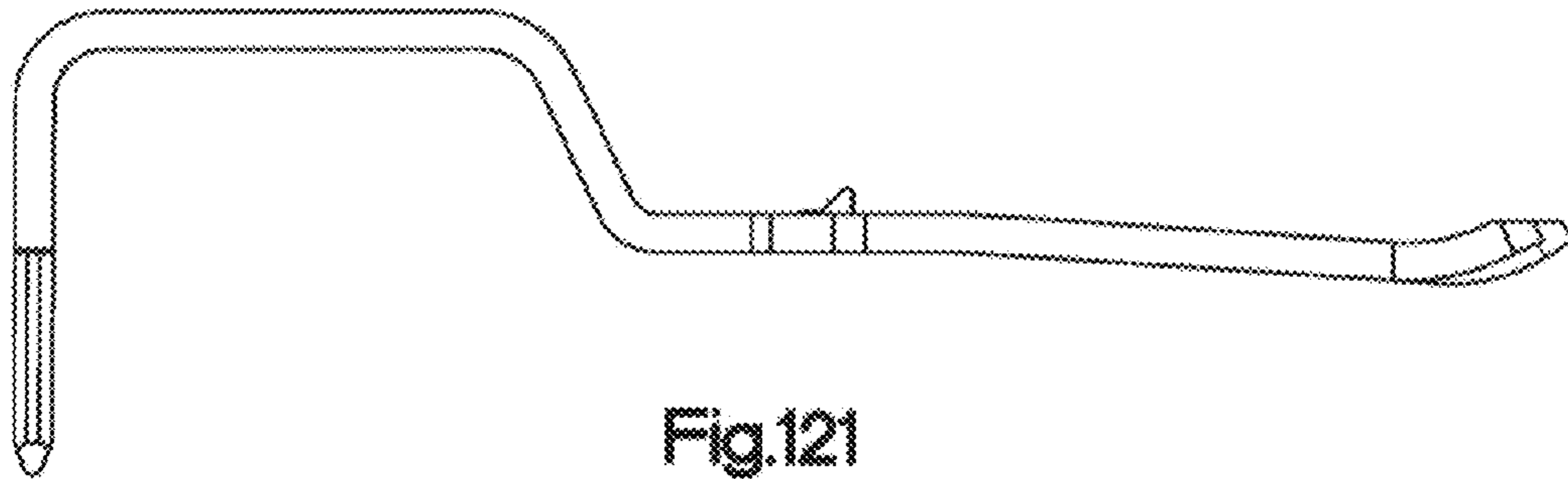

Fig.121

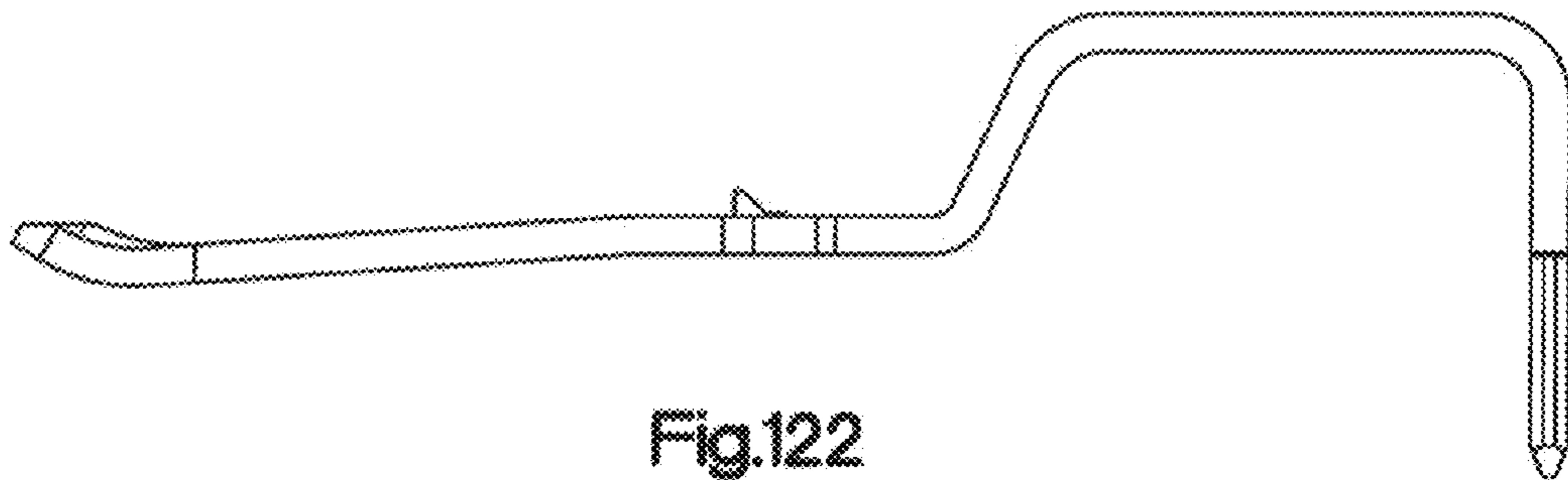

Fig.122

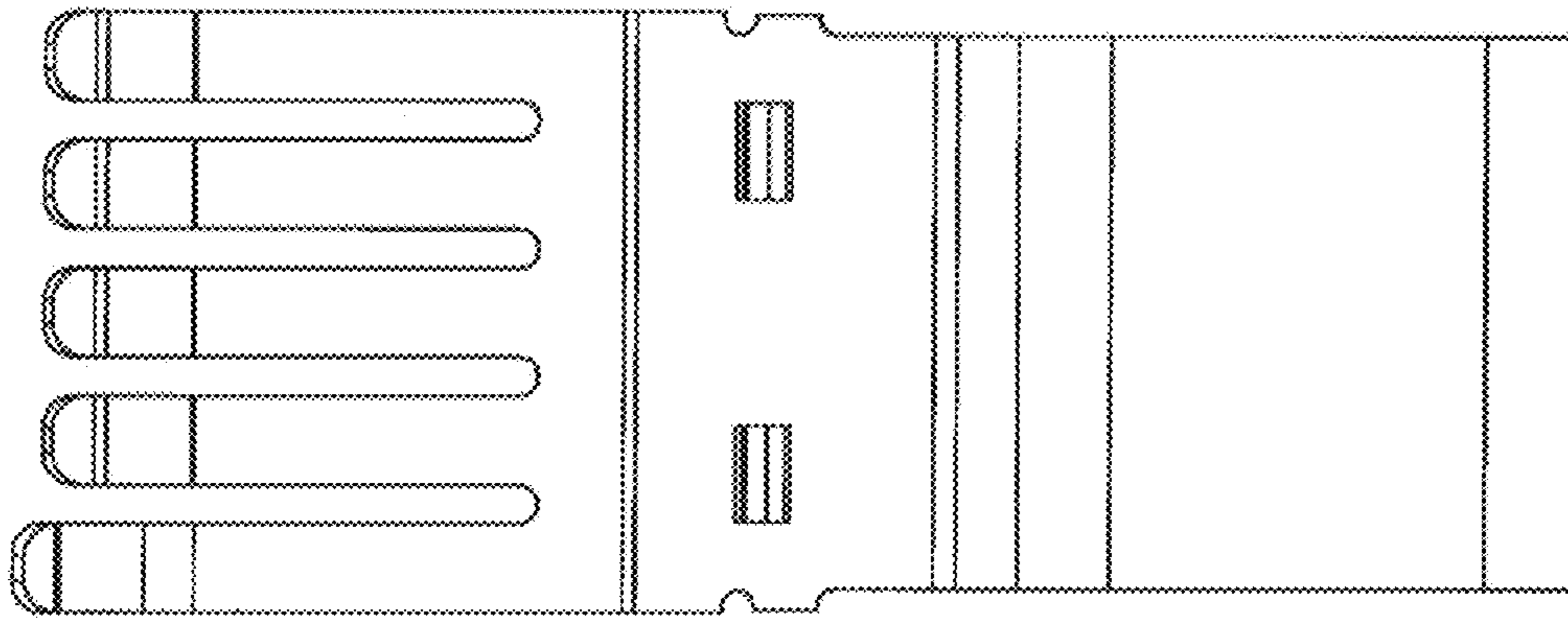

Fig.123

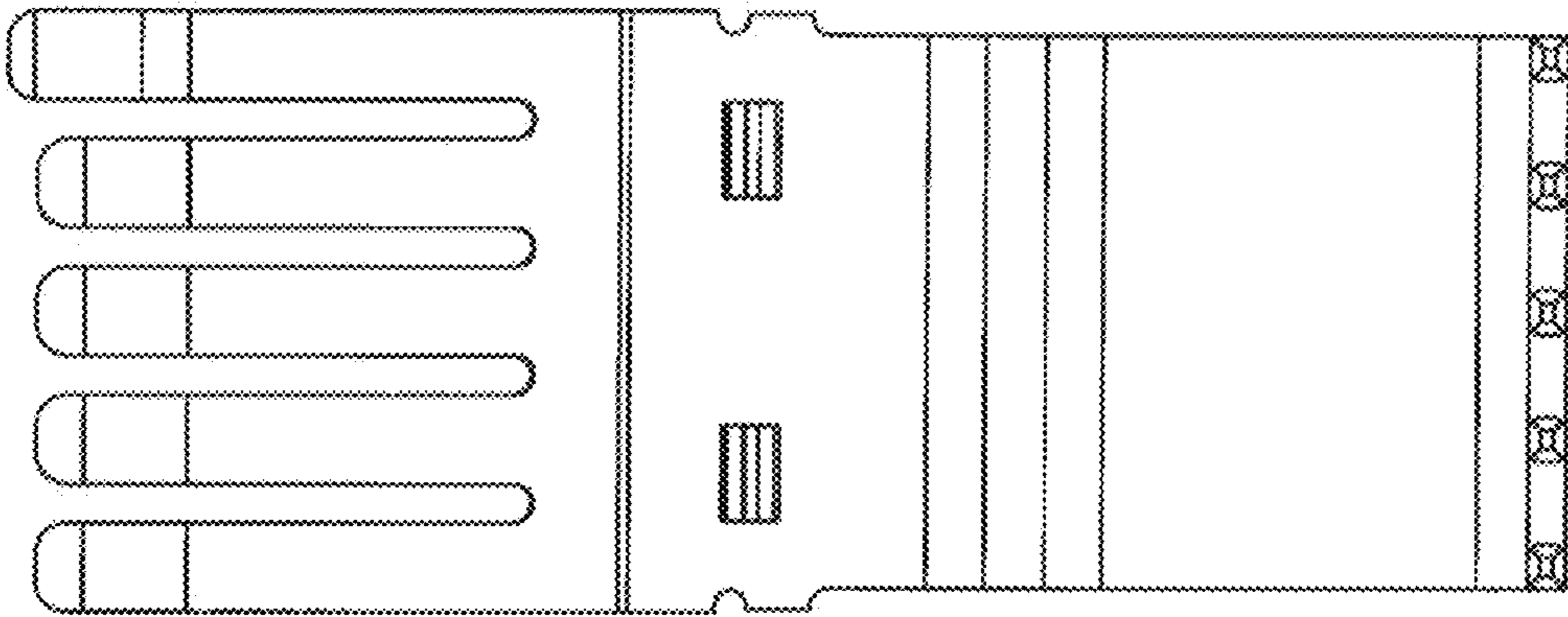

Fig.124

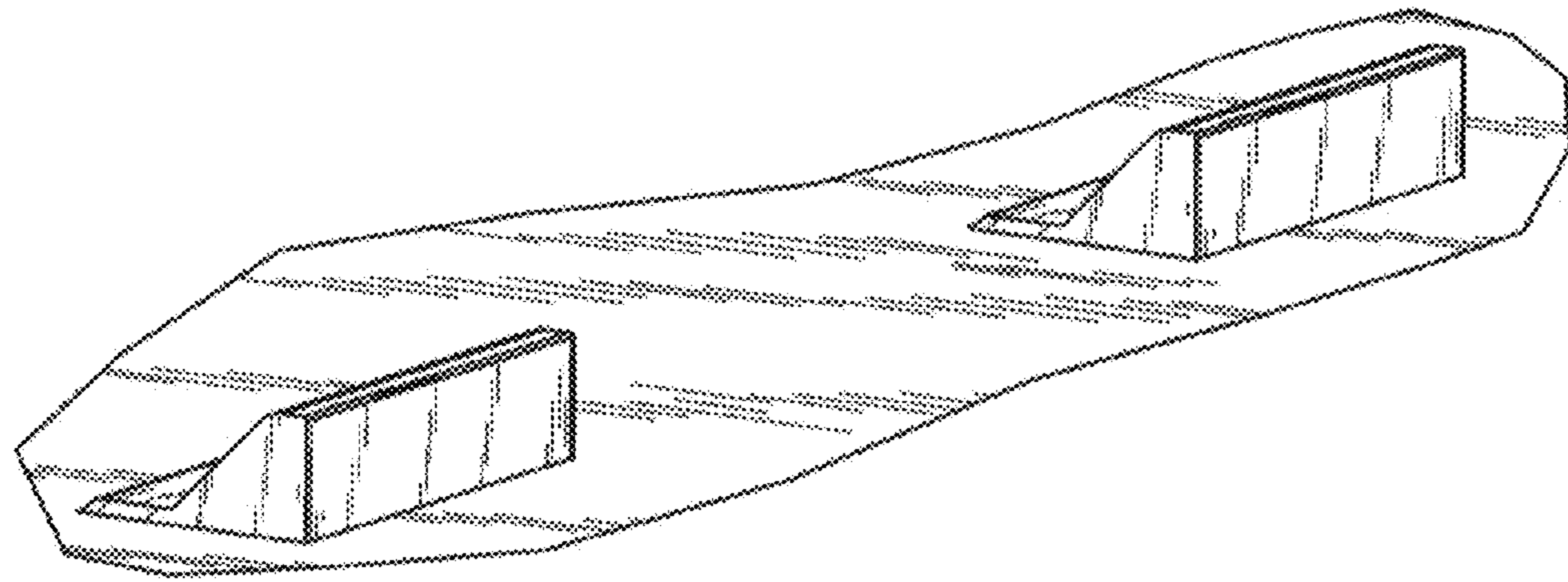

Fig.125

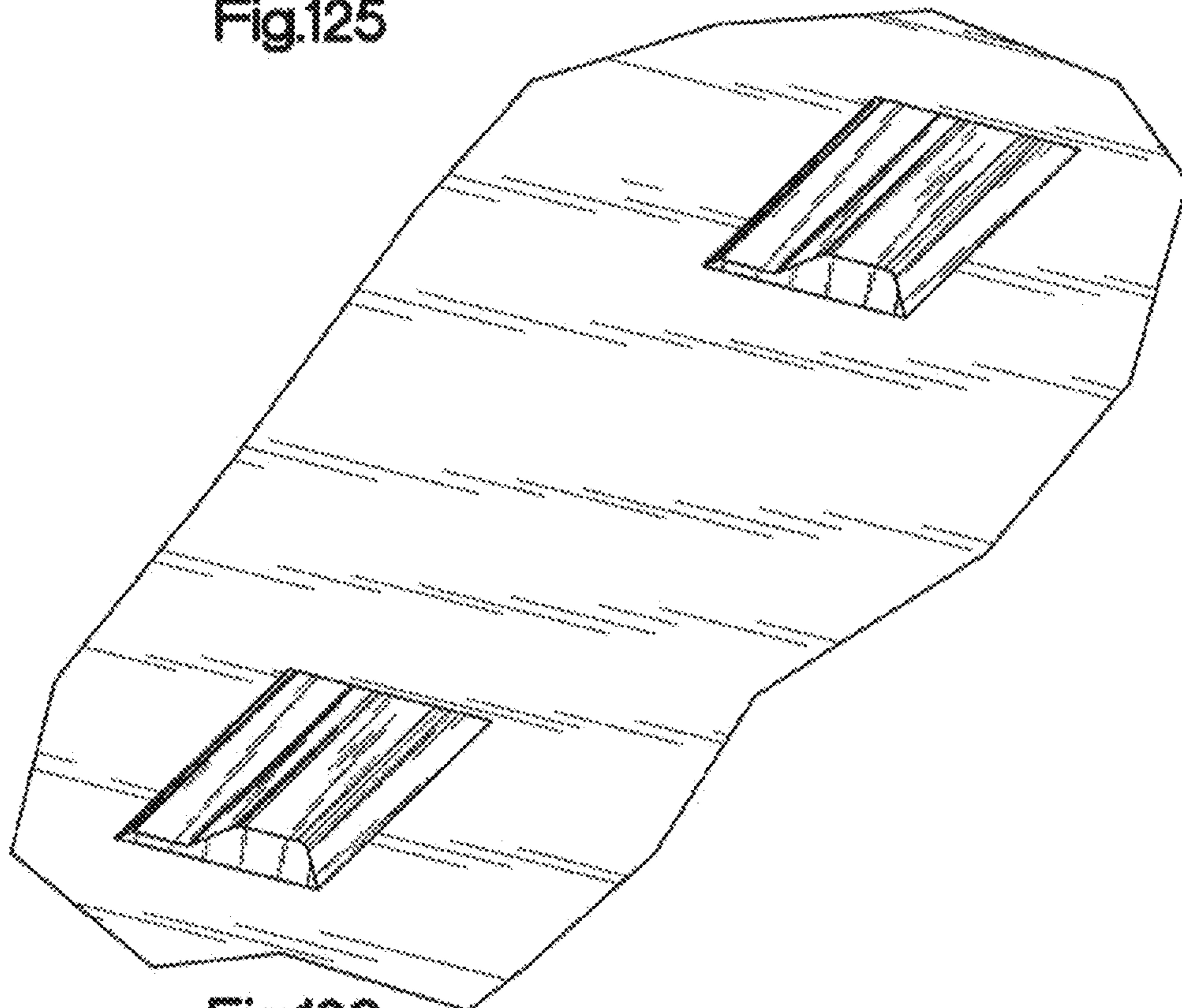

Fig.126

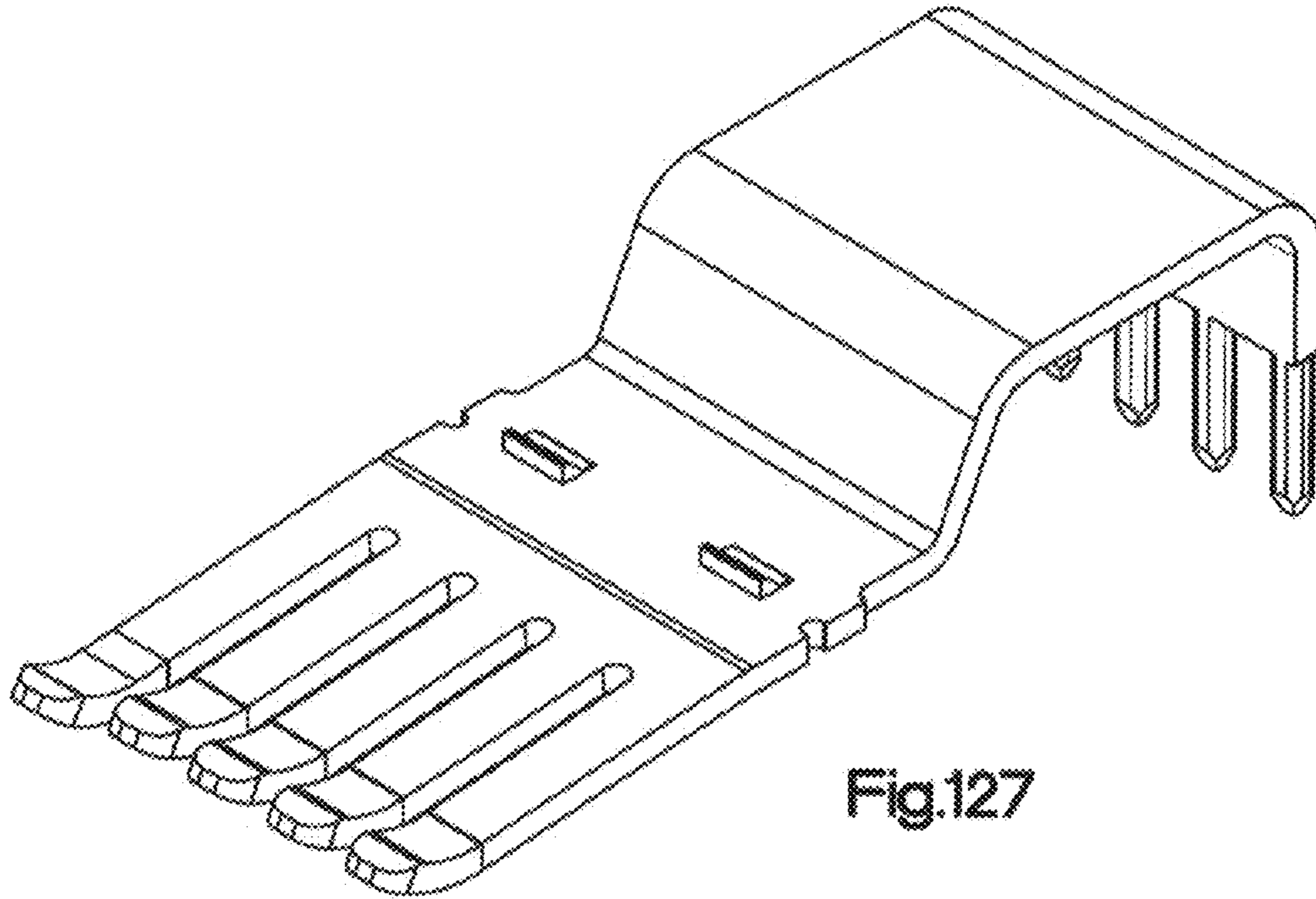

Fig.127

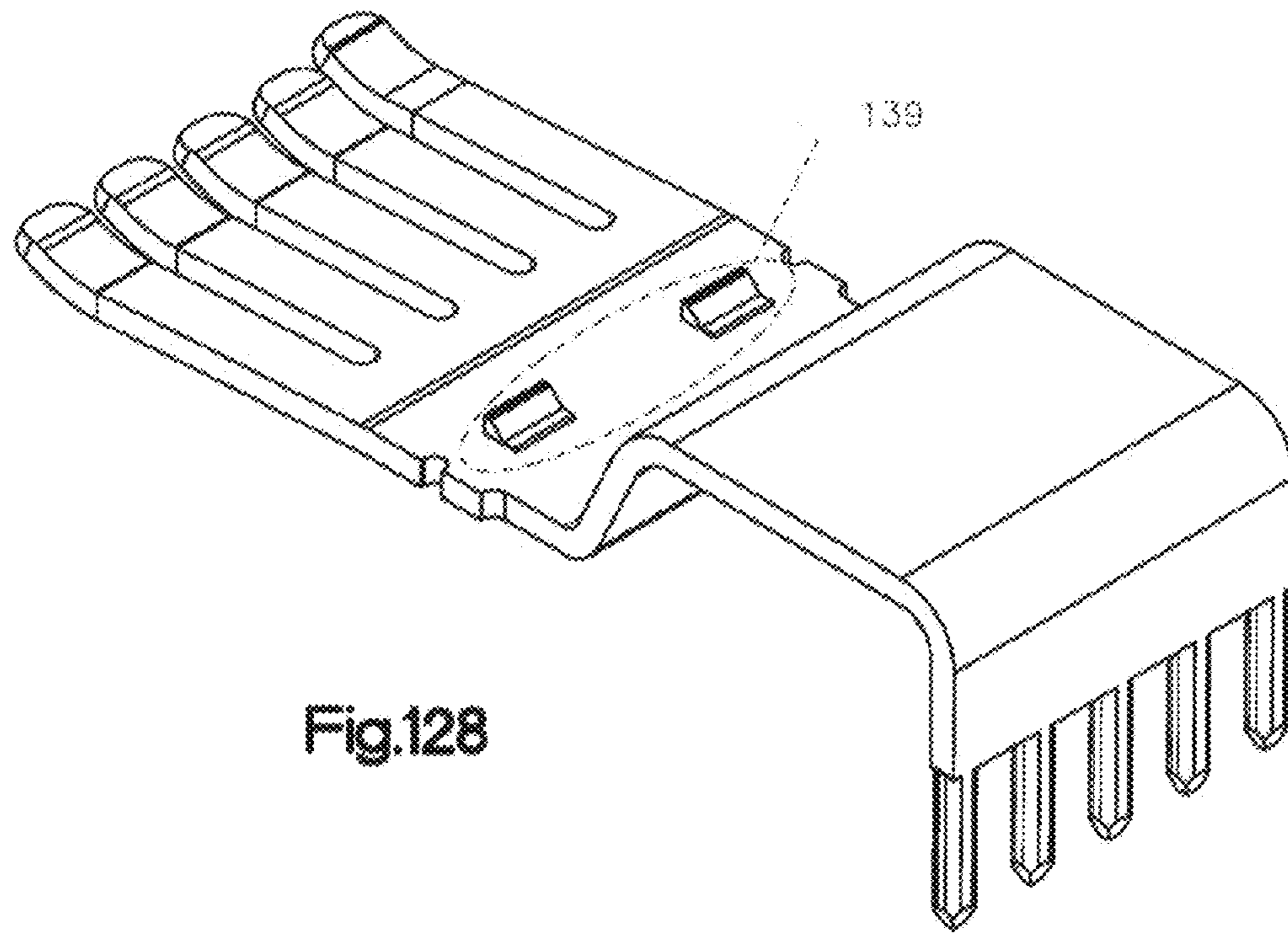

Fig.128

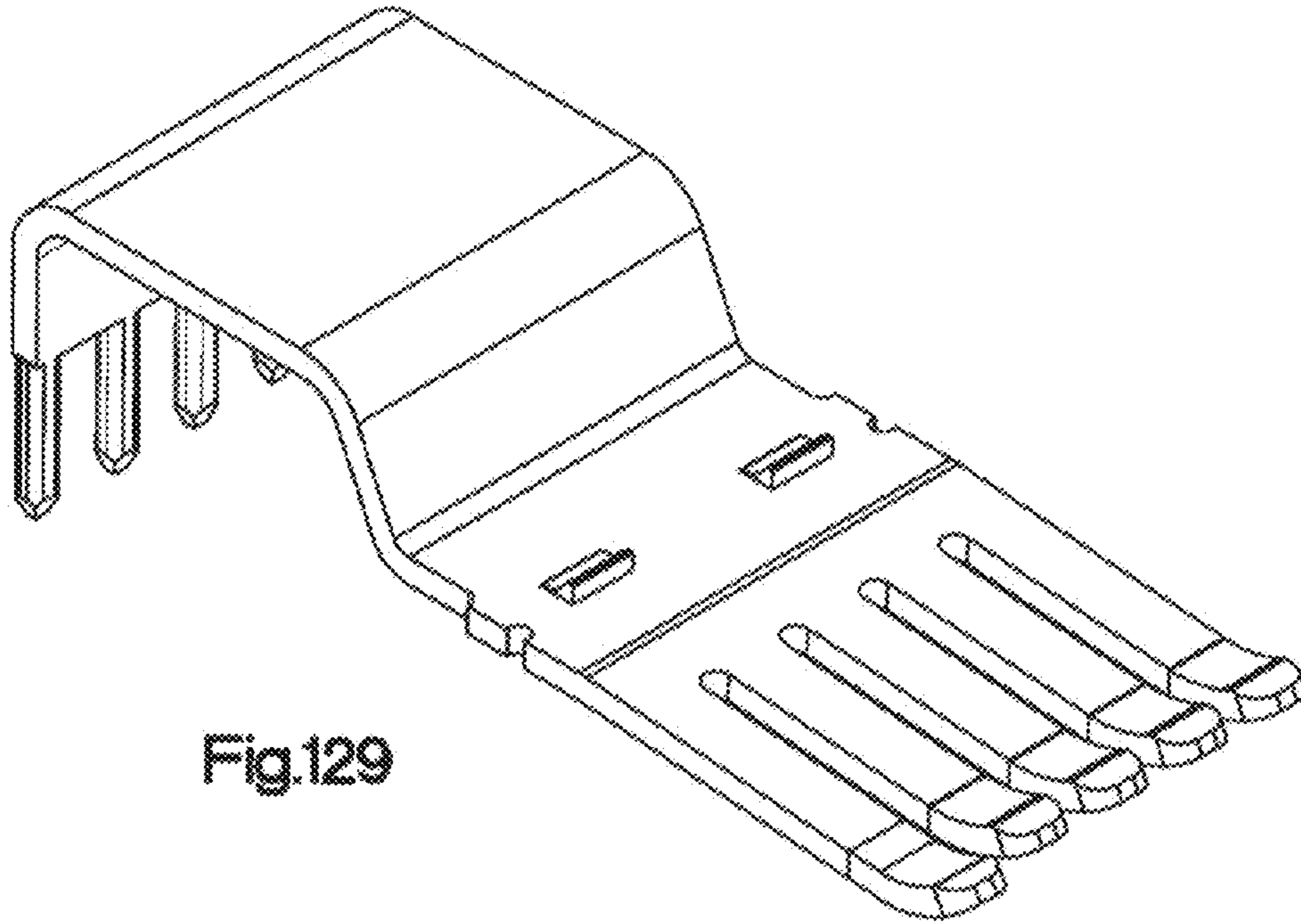

Fig.129

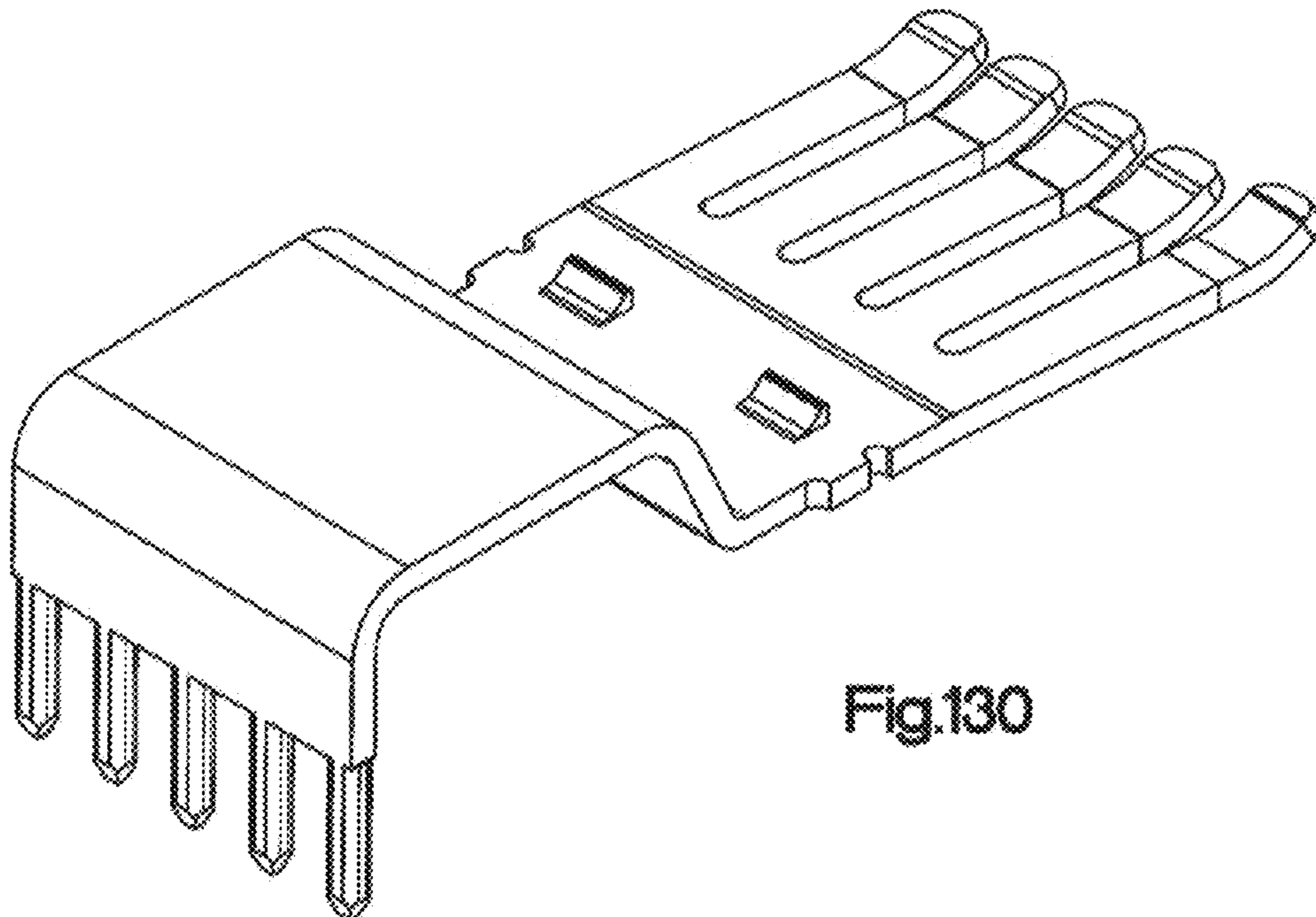

Fig.130

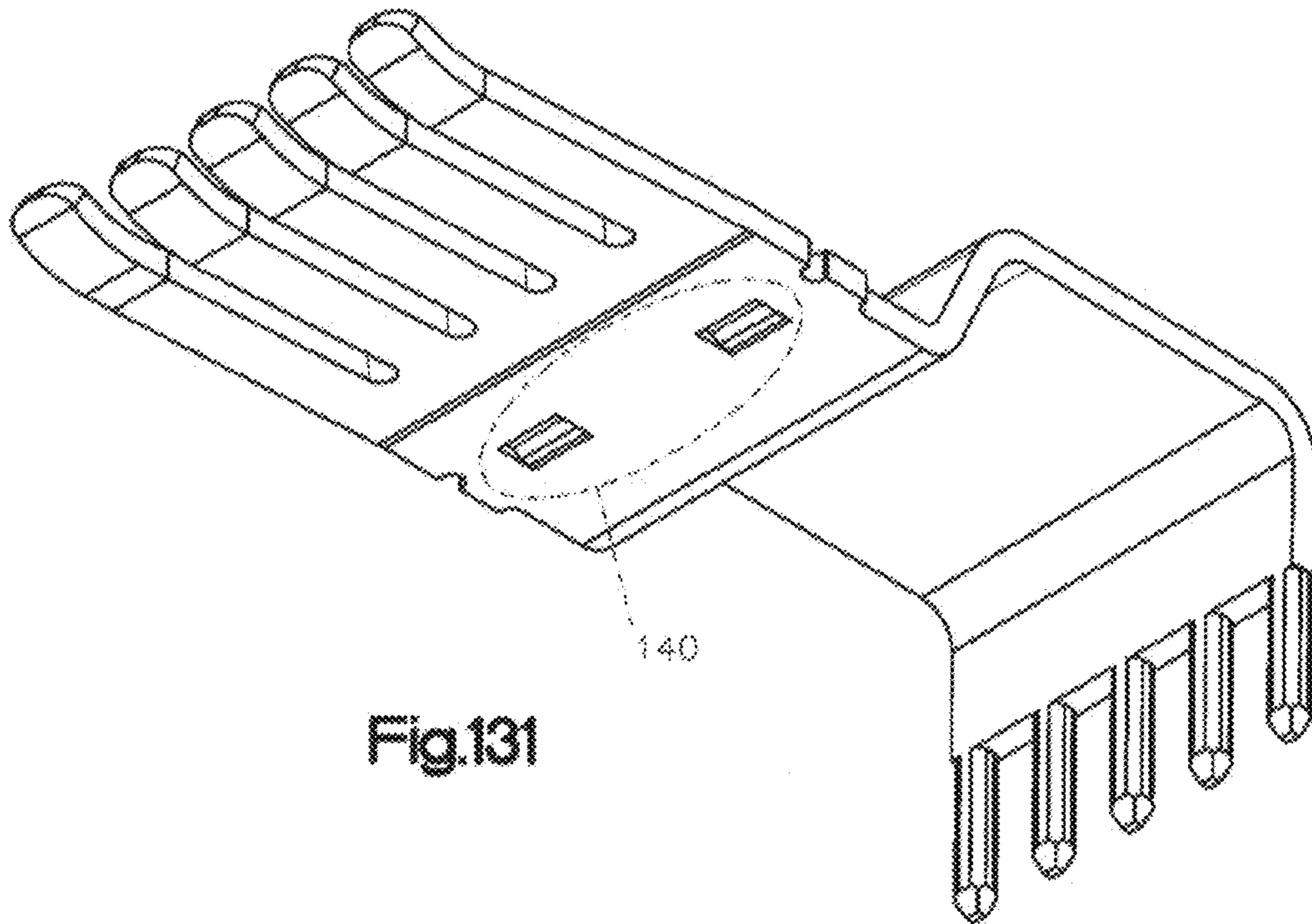

Fig.131

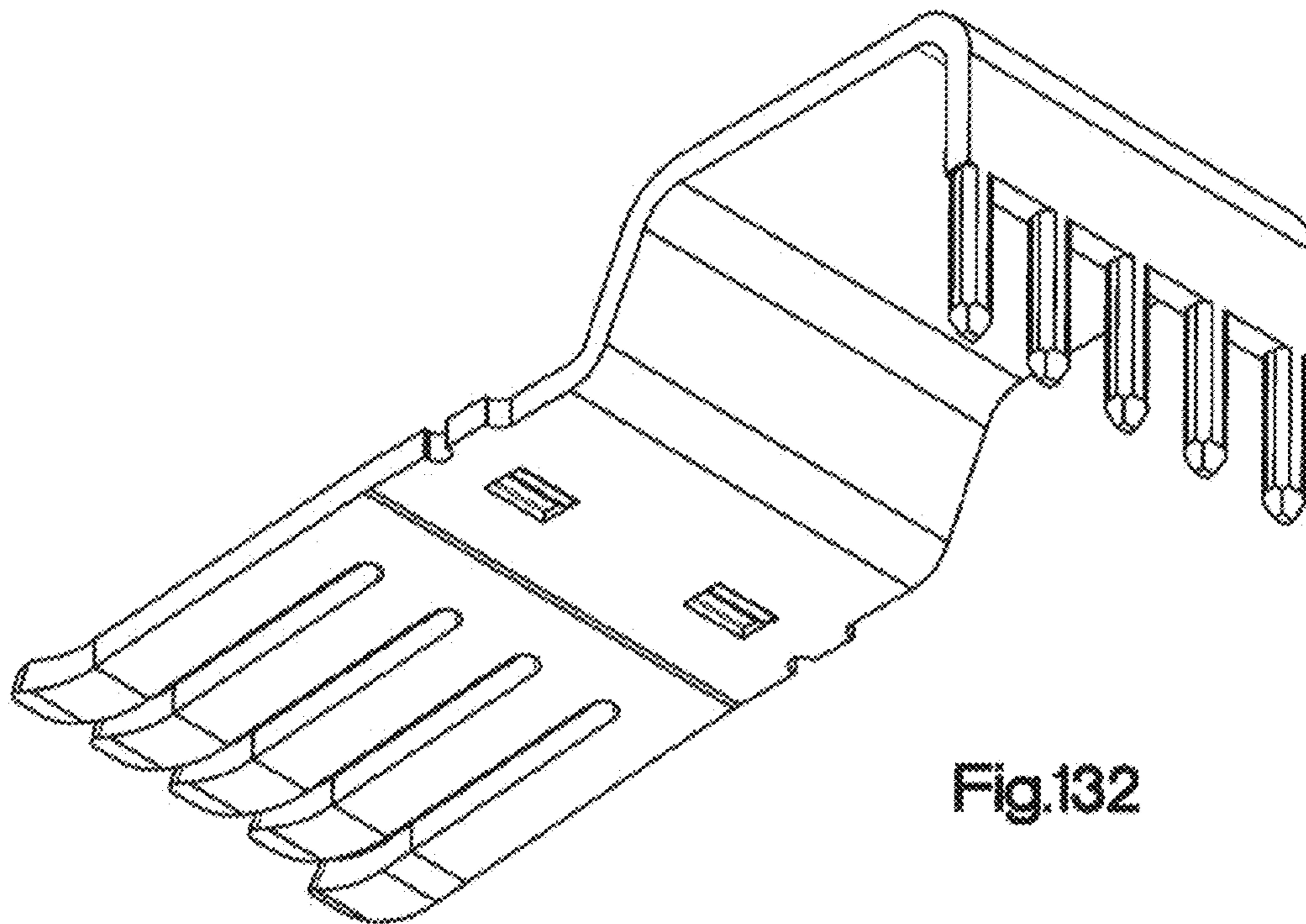

Fig.132

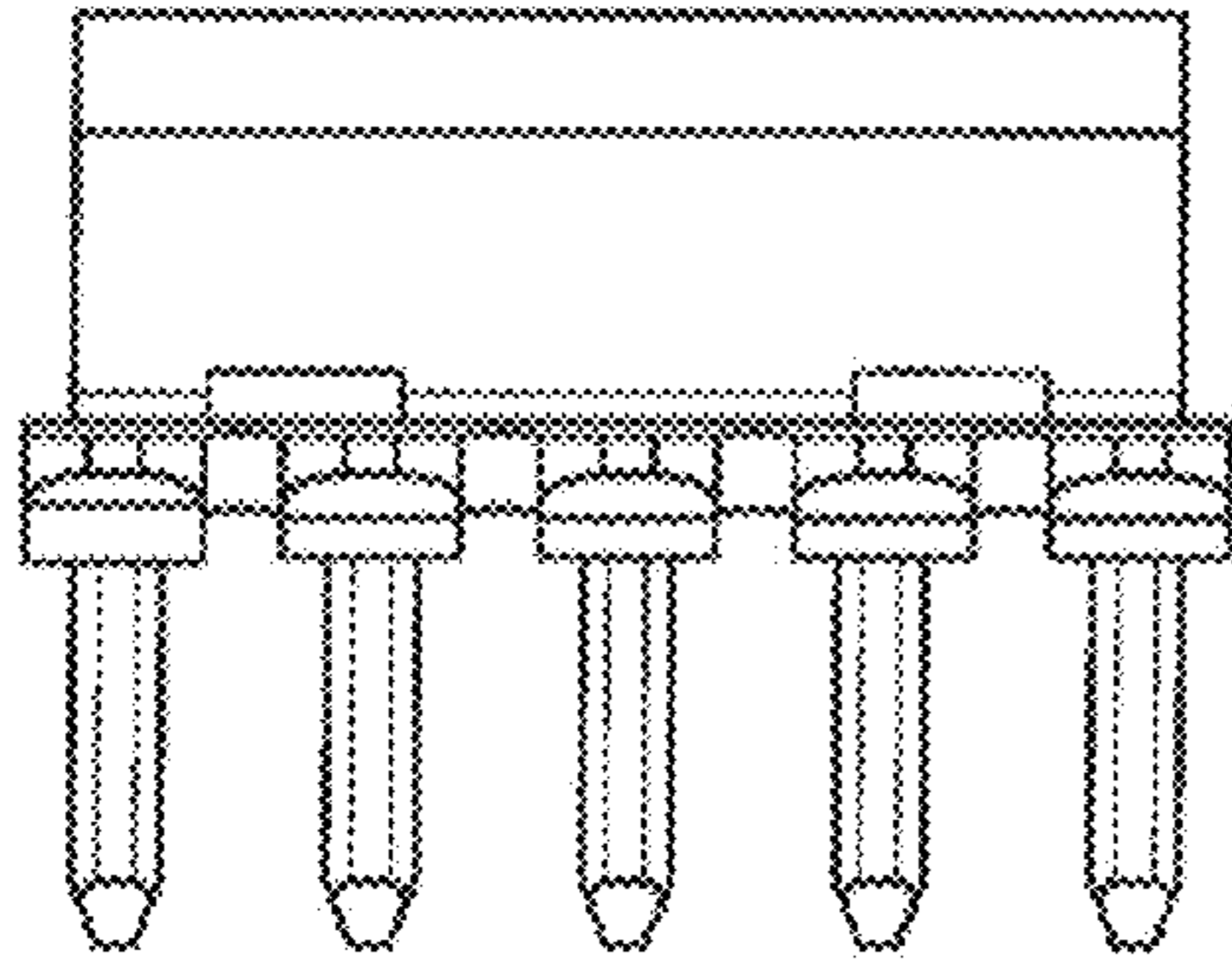

Fig.133

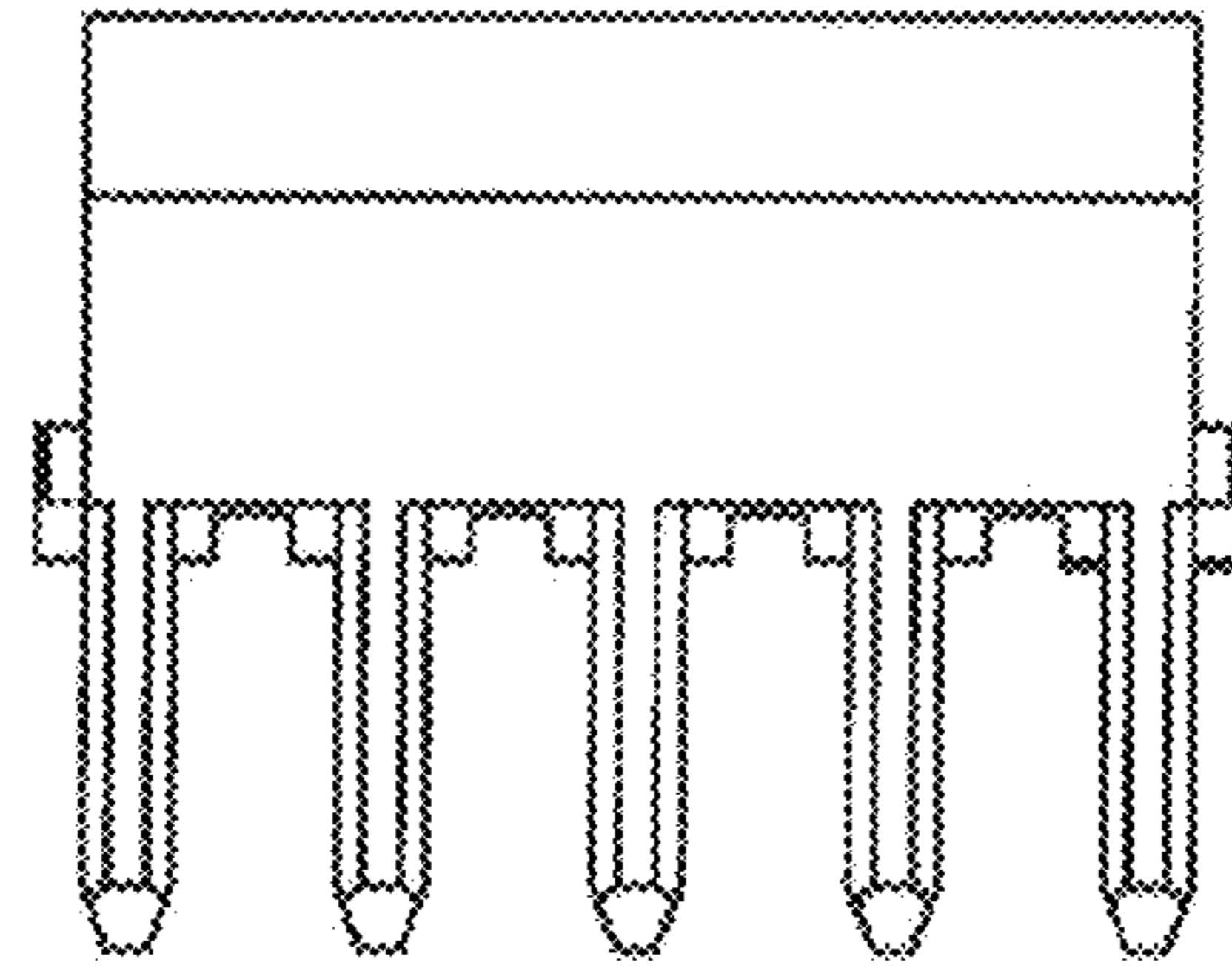

Fig.134

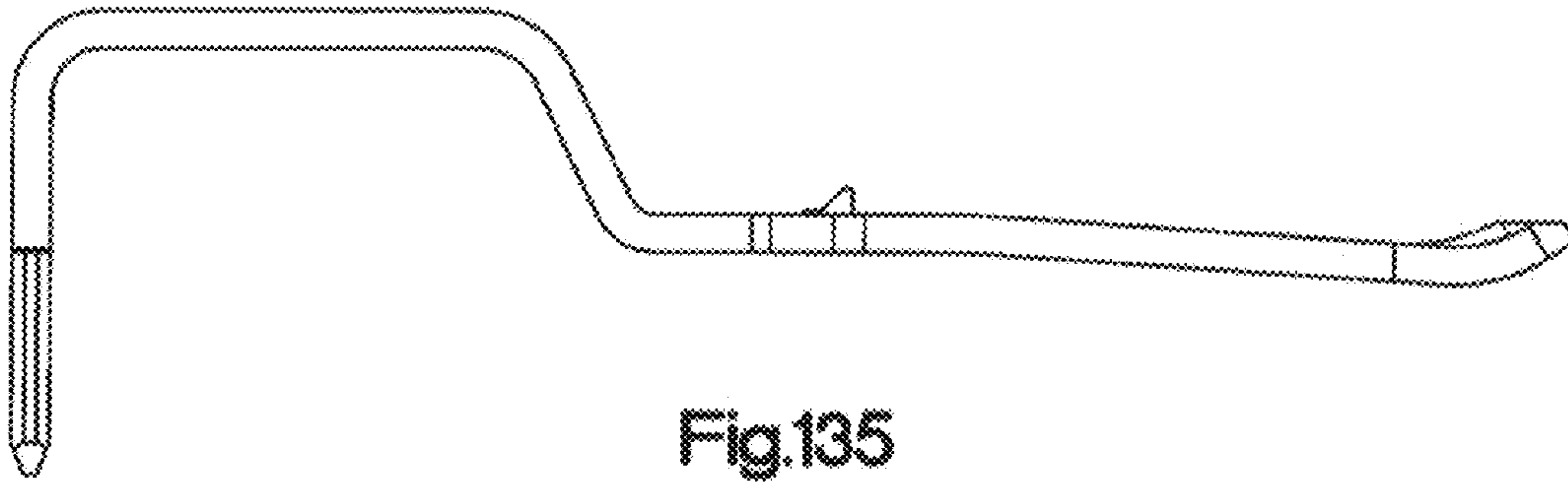

Fig.135

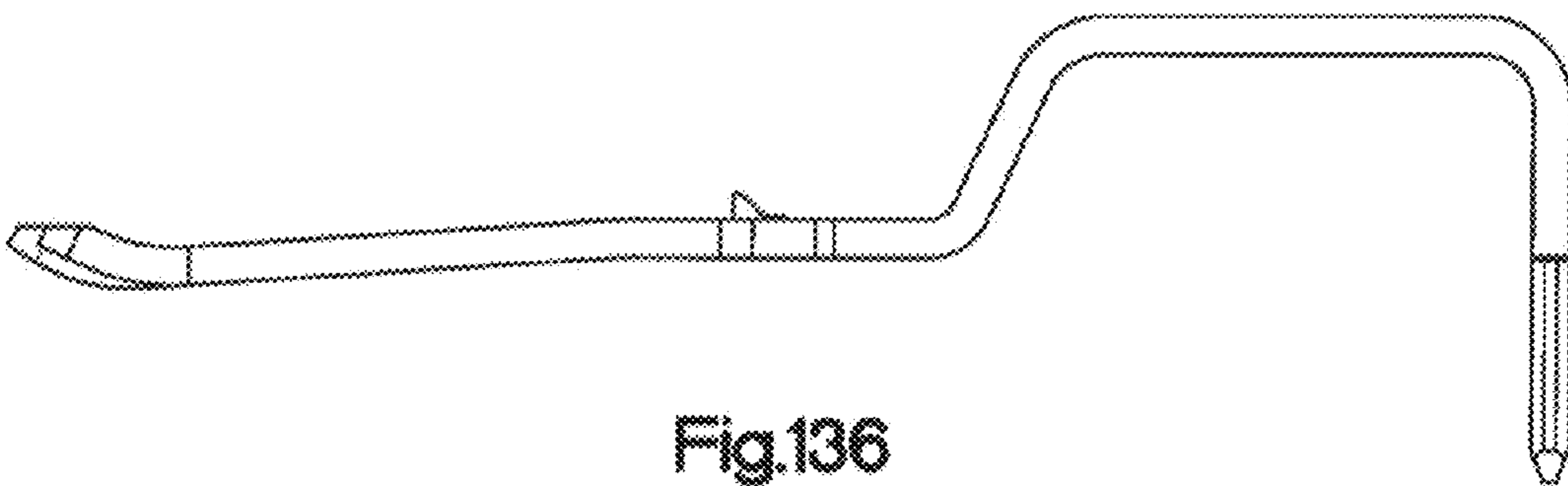

Fig.136

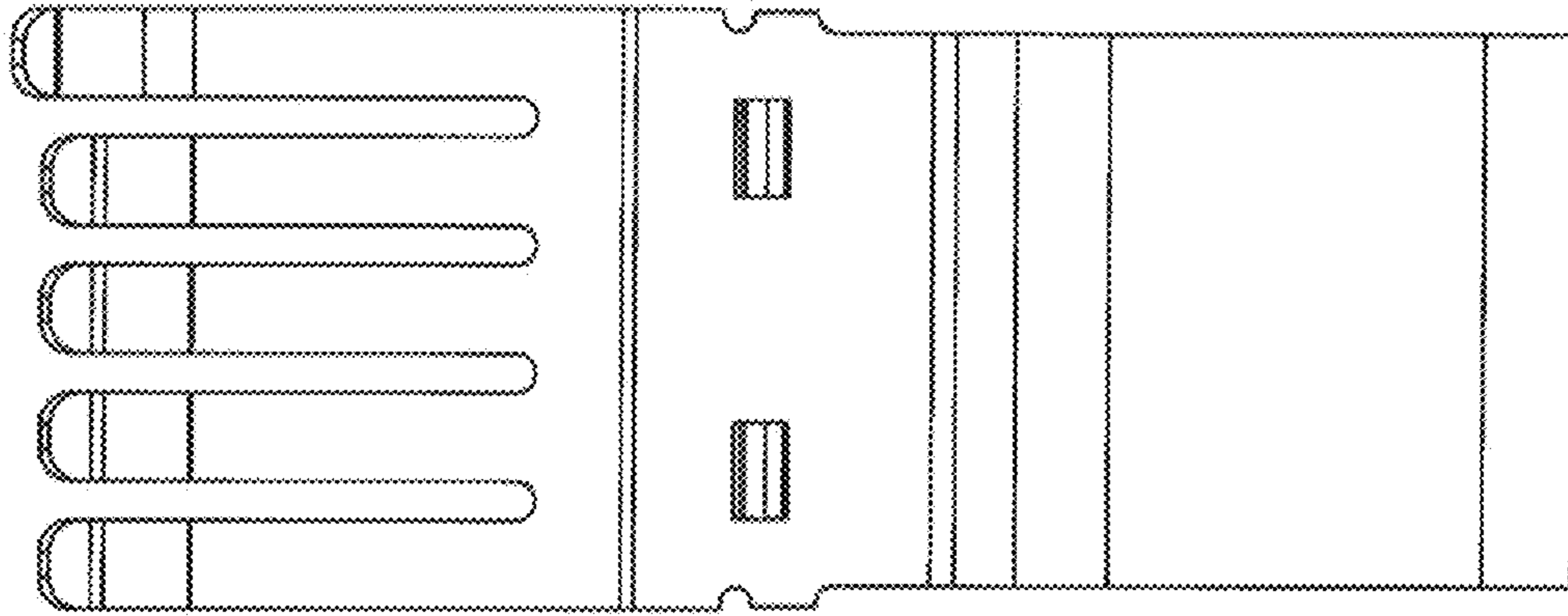

Fig.137

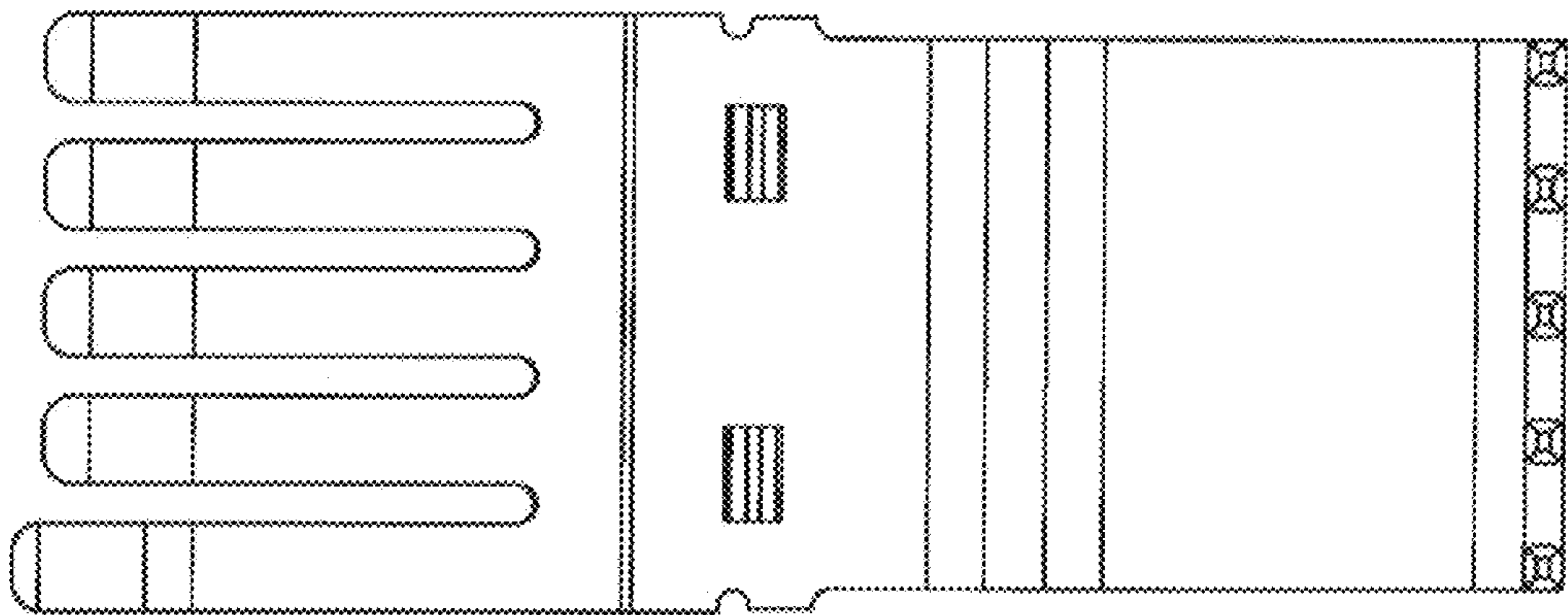

Fig.138

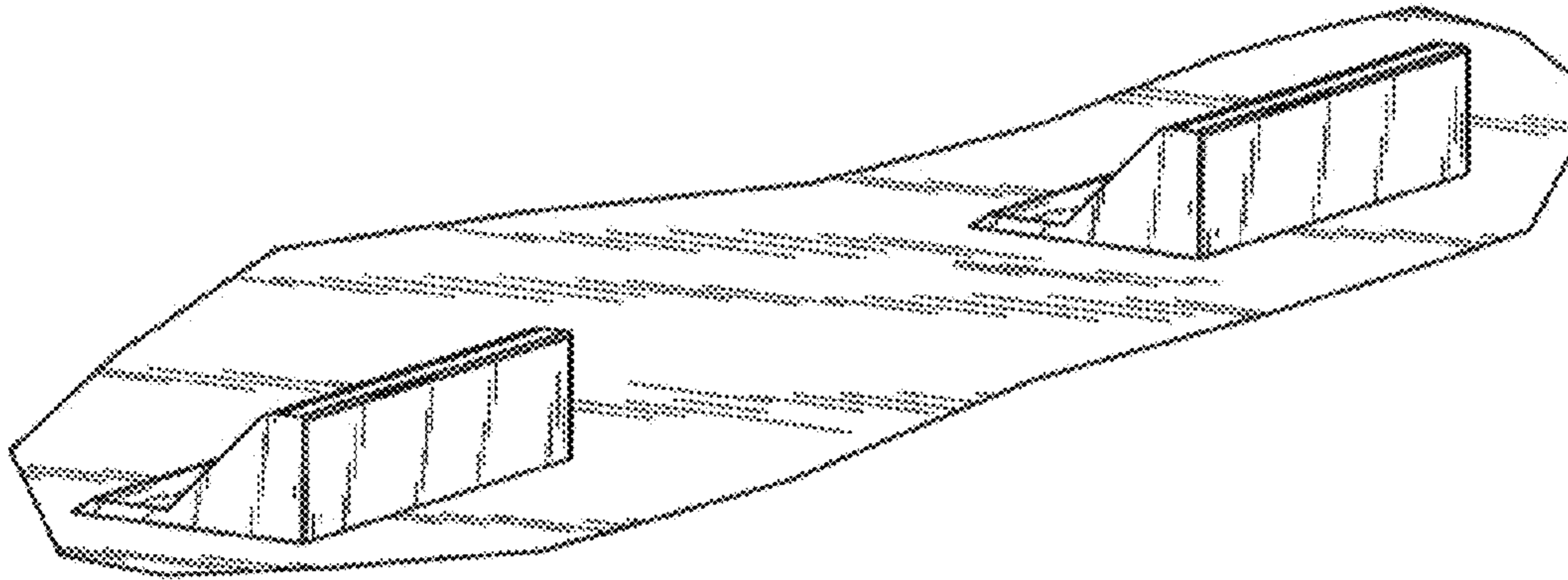

Fig.139

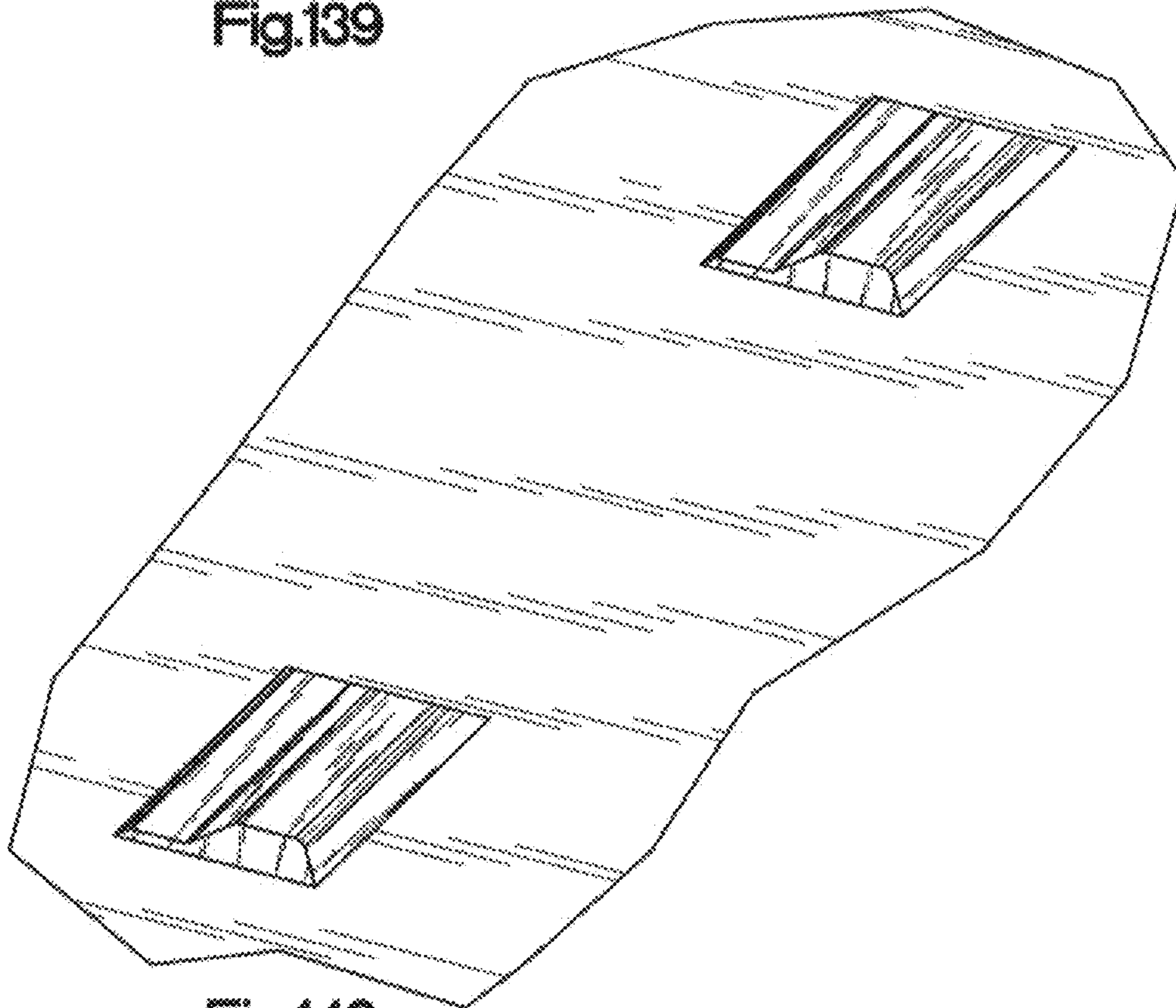

Fig.140

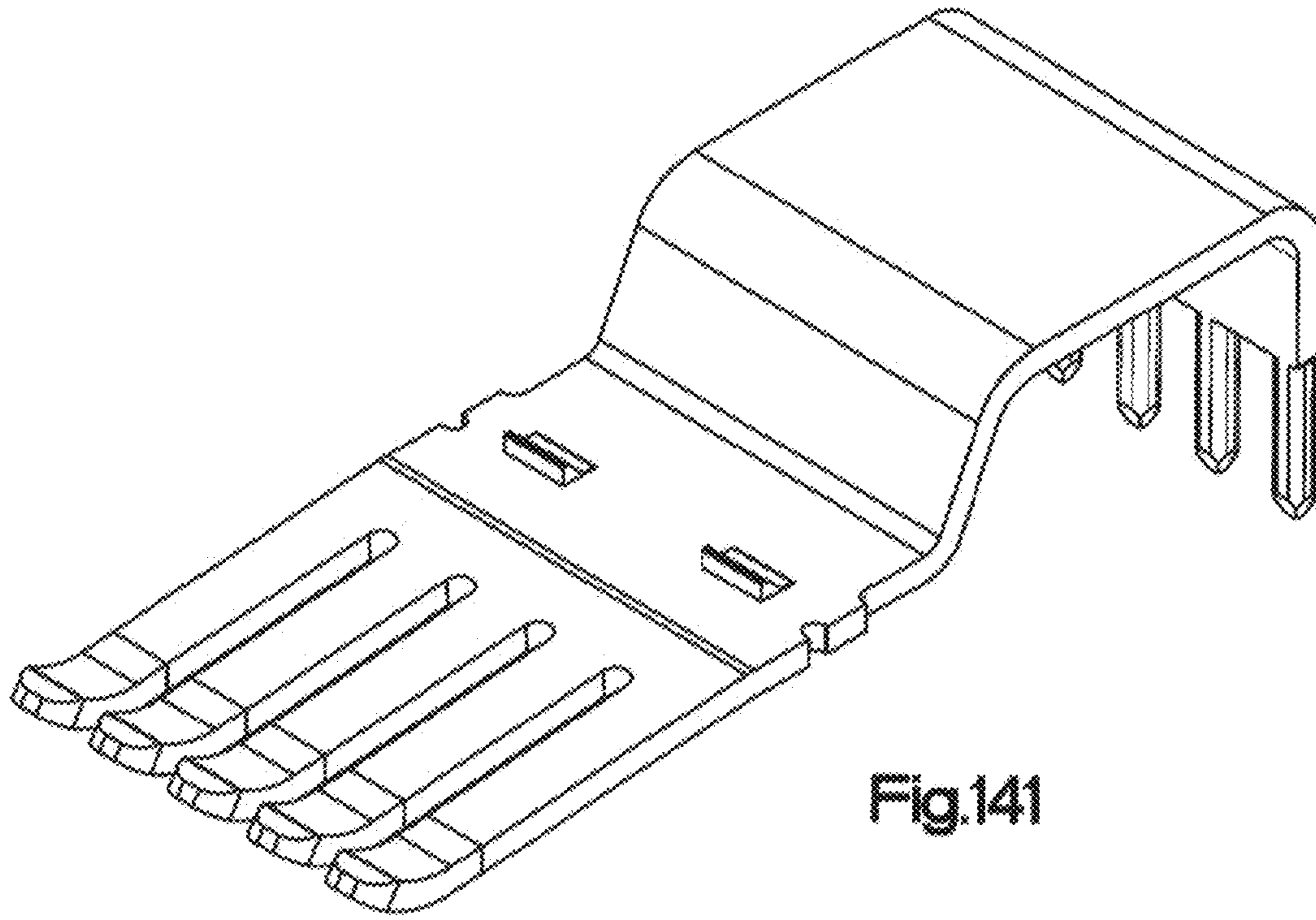

Fig.141

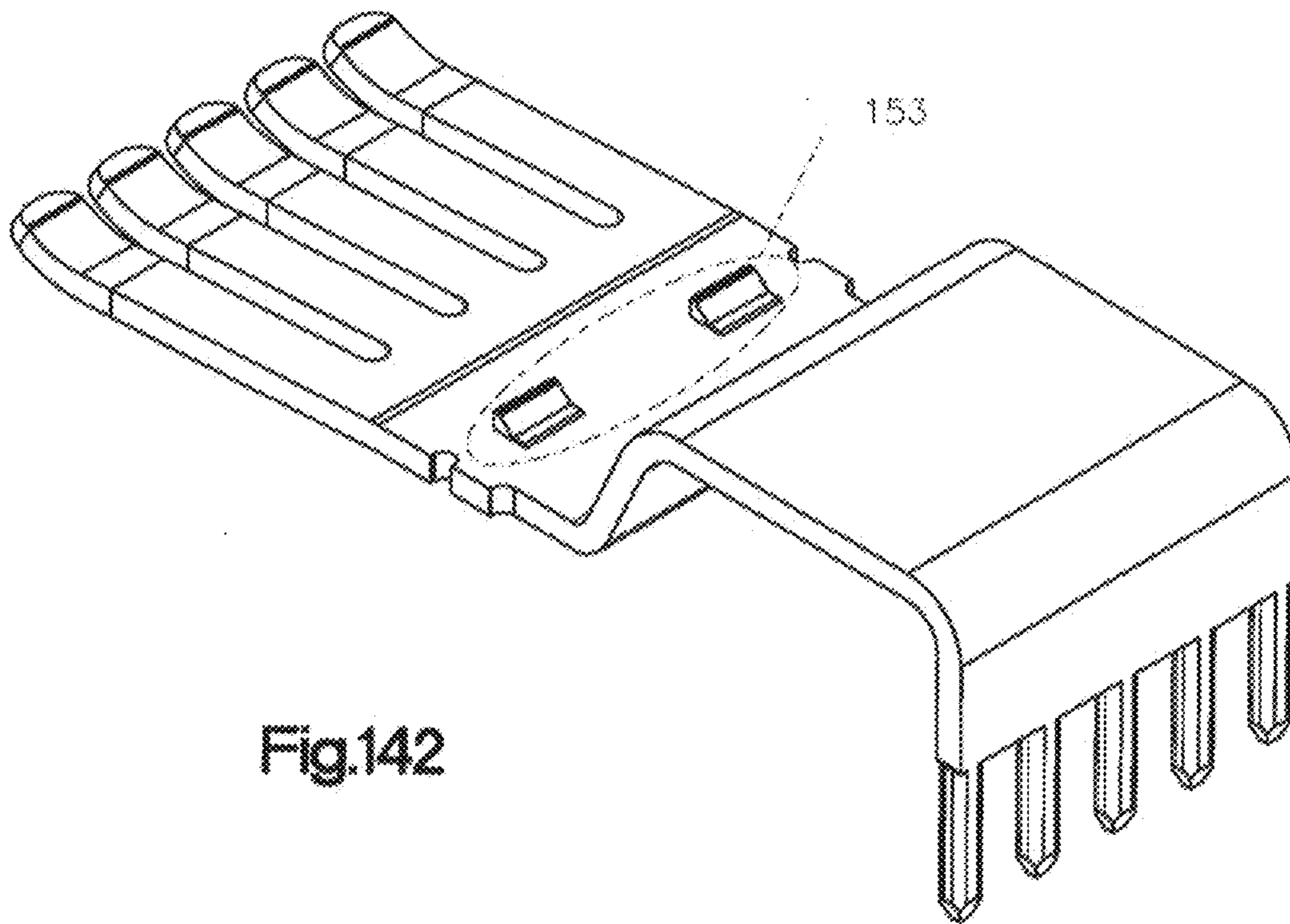

Fig.142

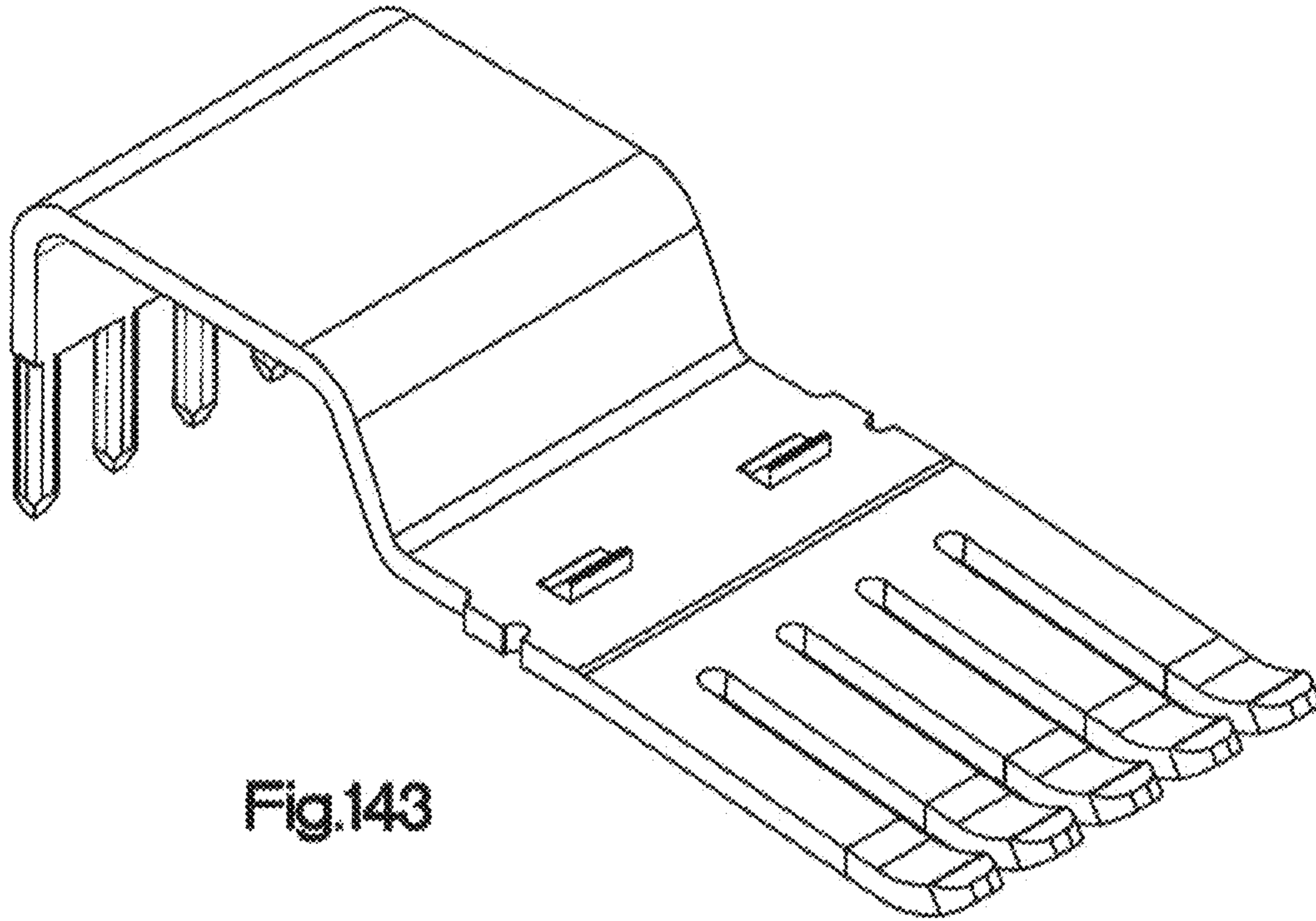

Fig.143

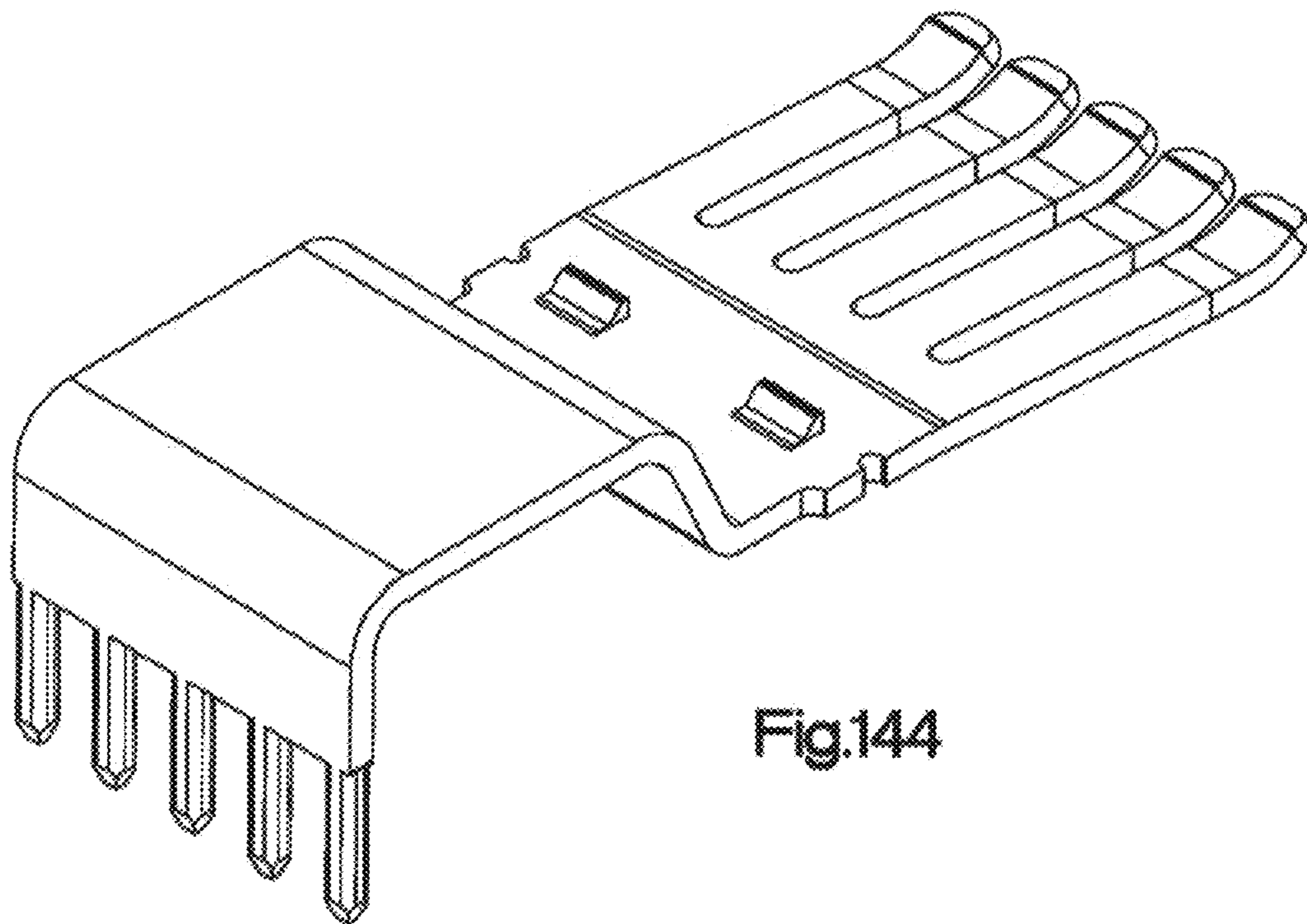

Fig.144

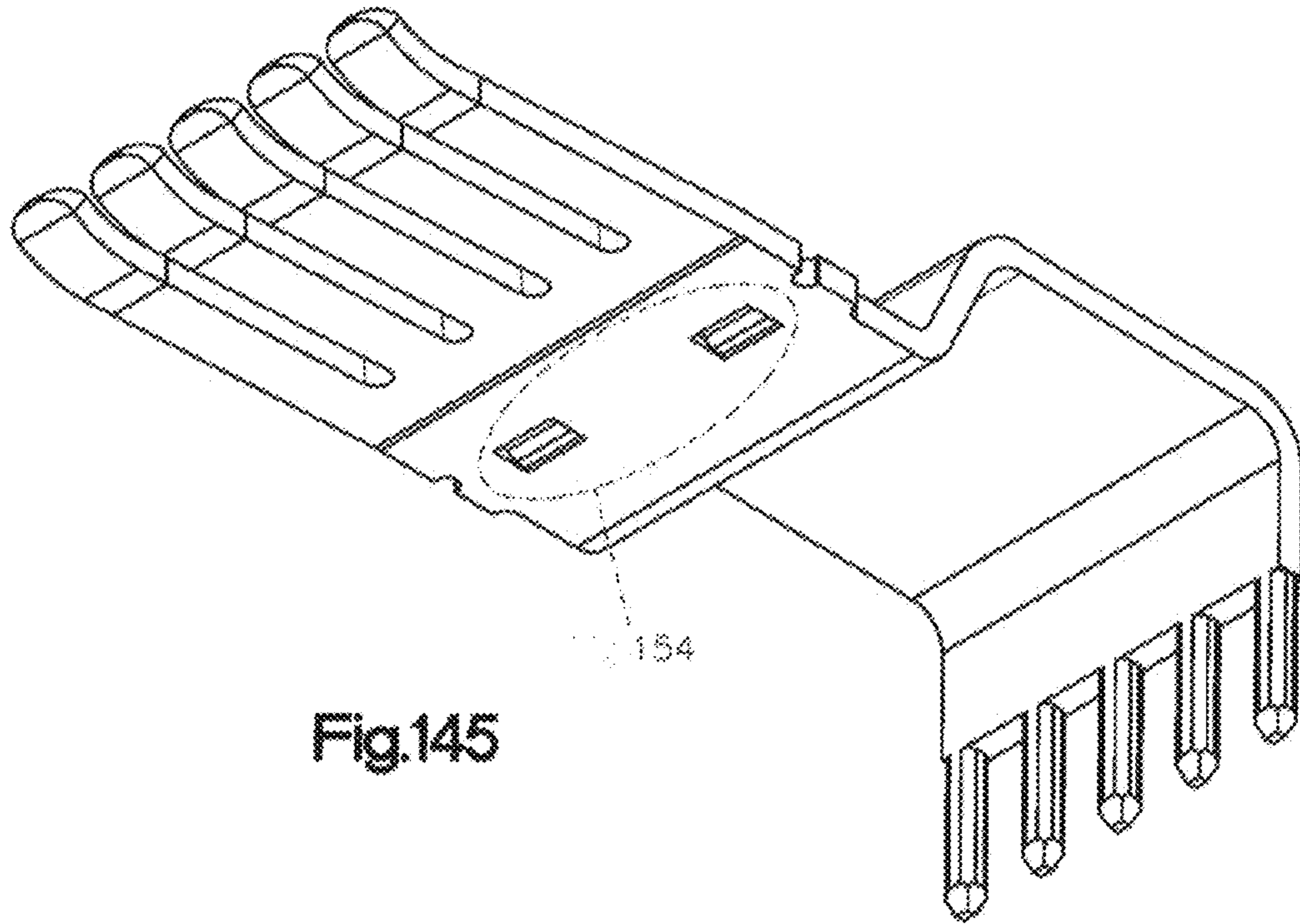

Fig.145

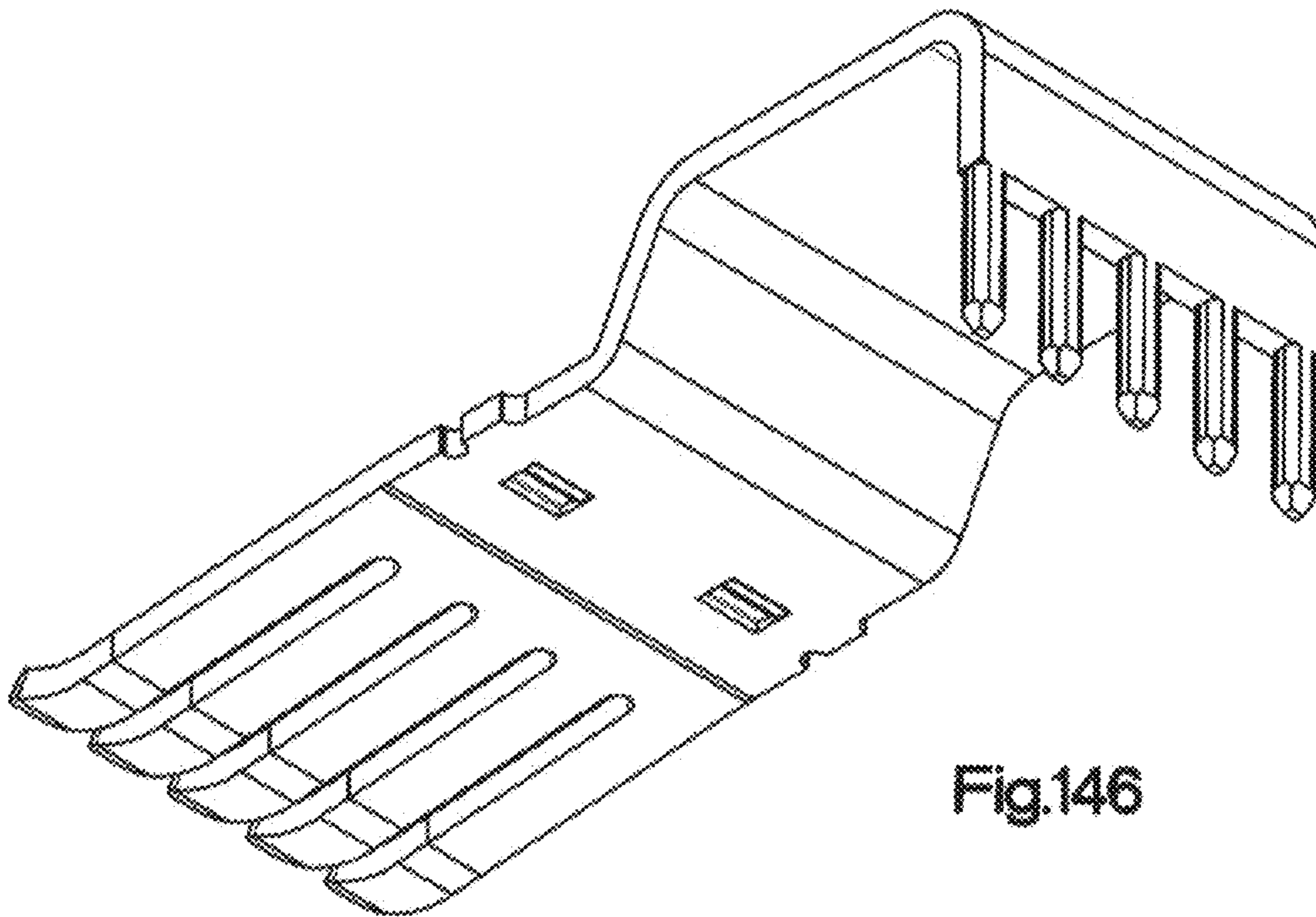

Fig.146

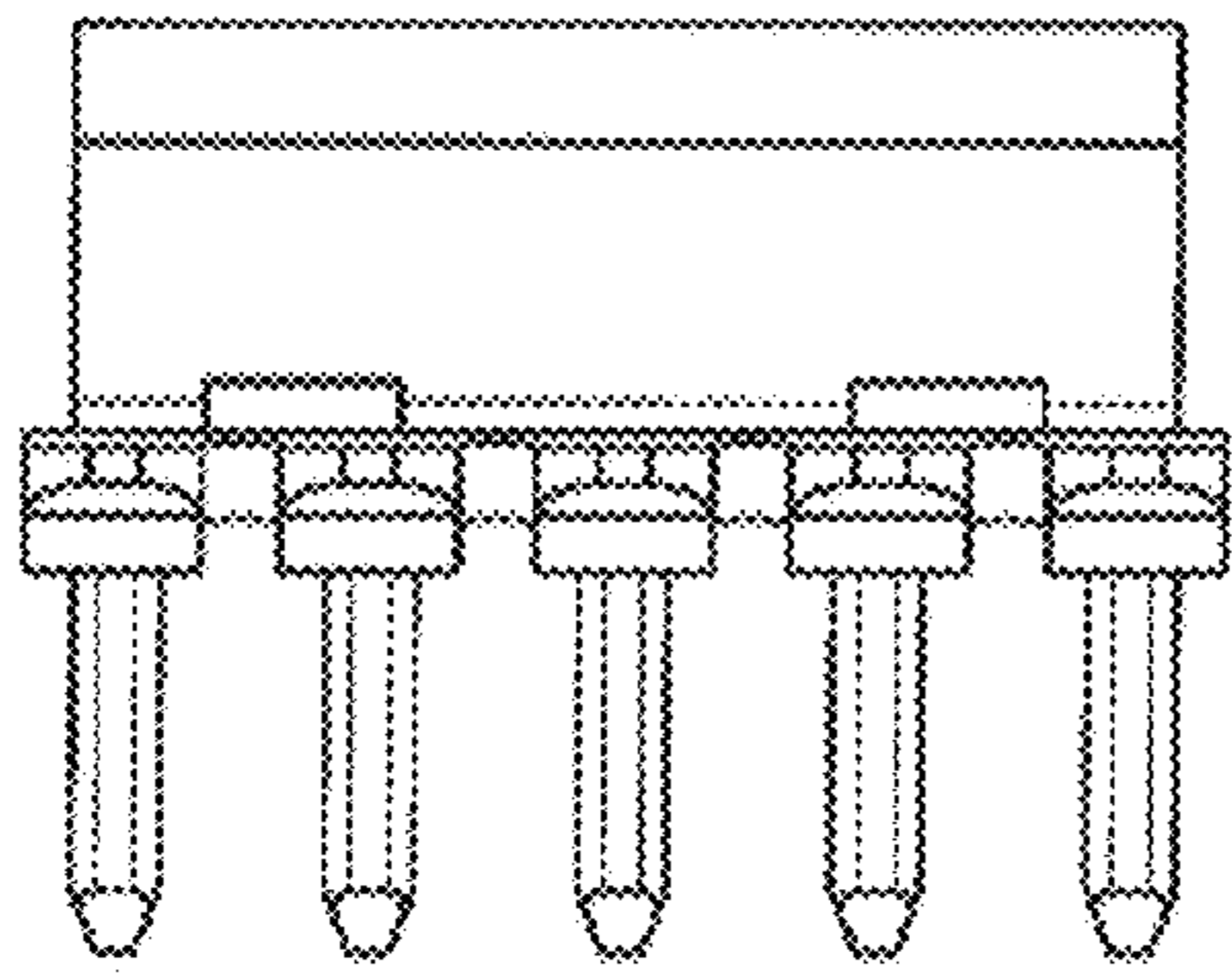

Fig.147

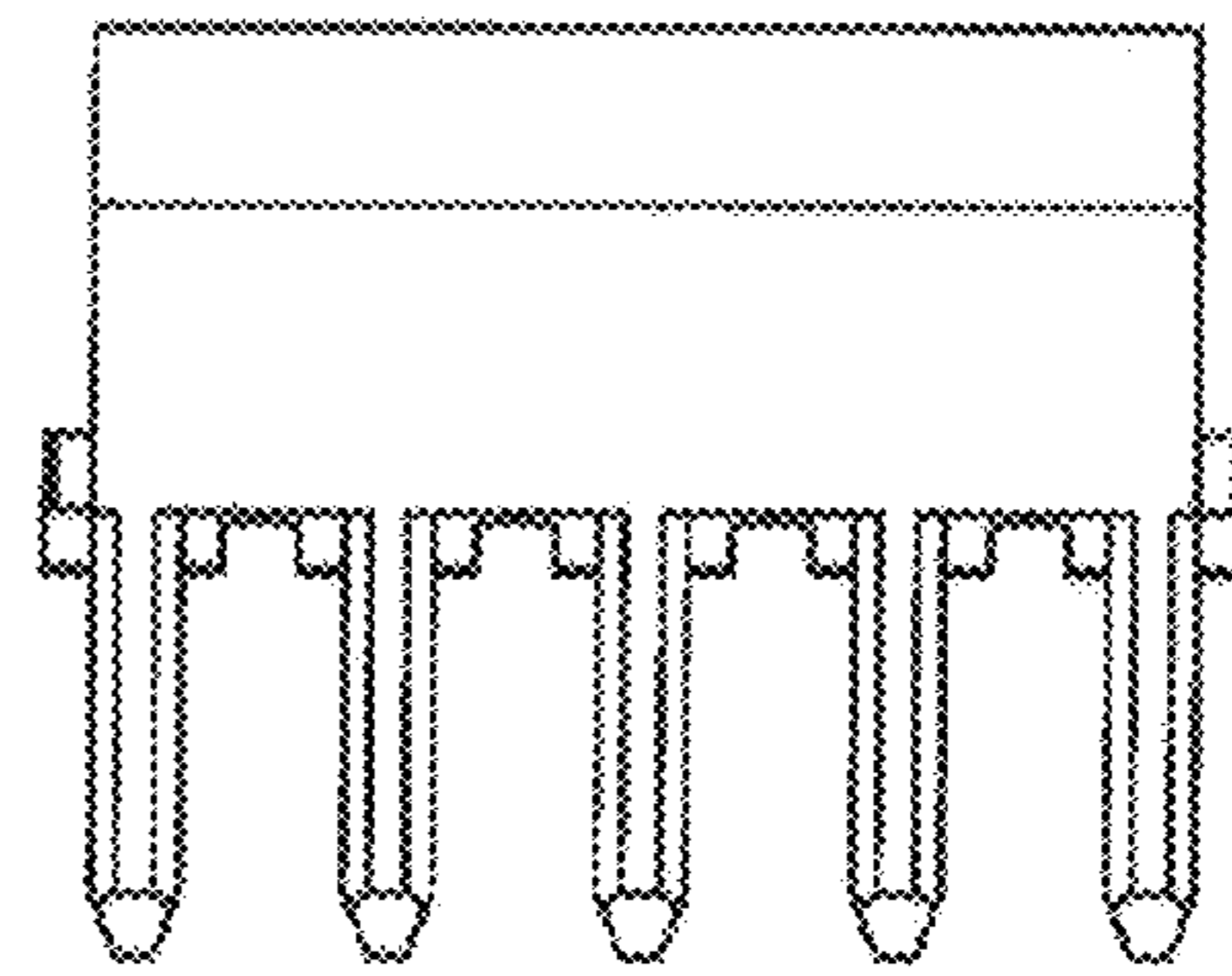

Fig.148

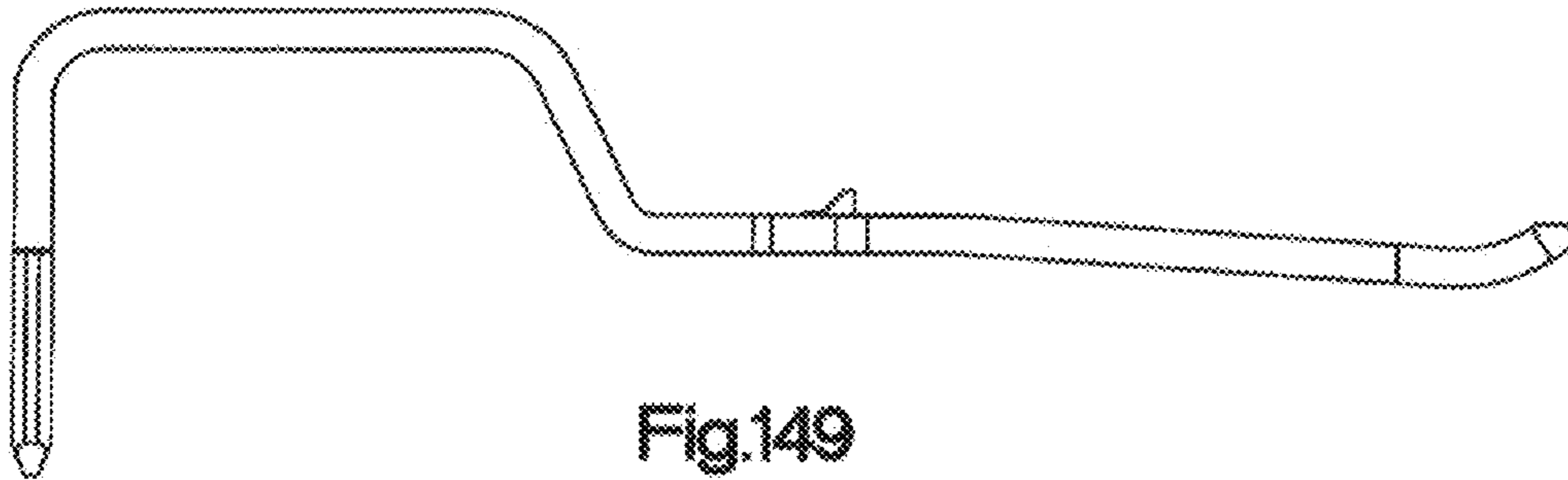

Fig.149

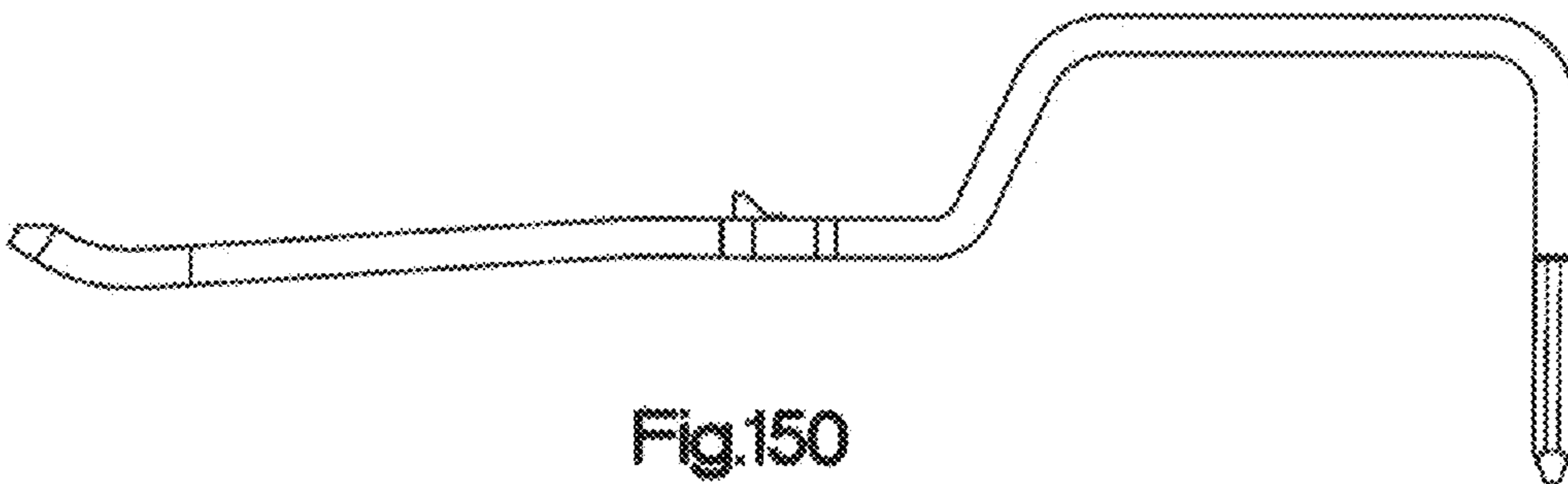

Fig.150

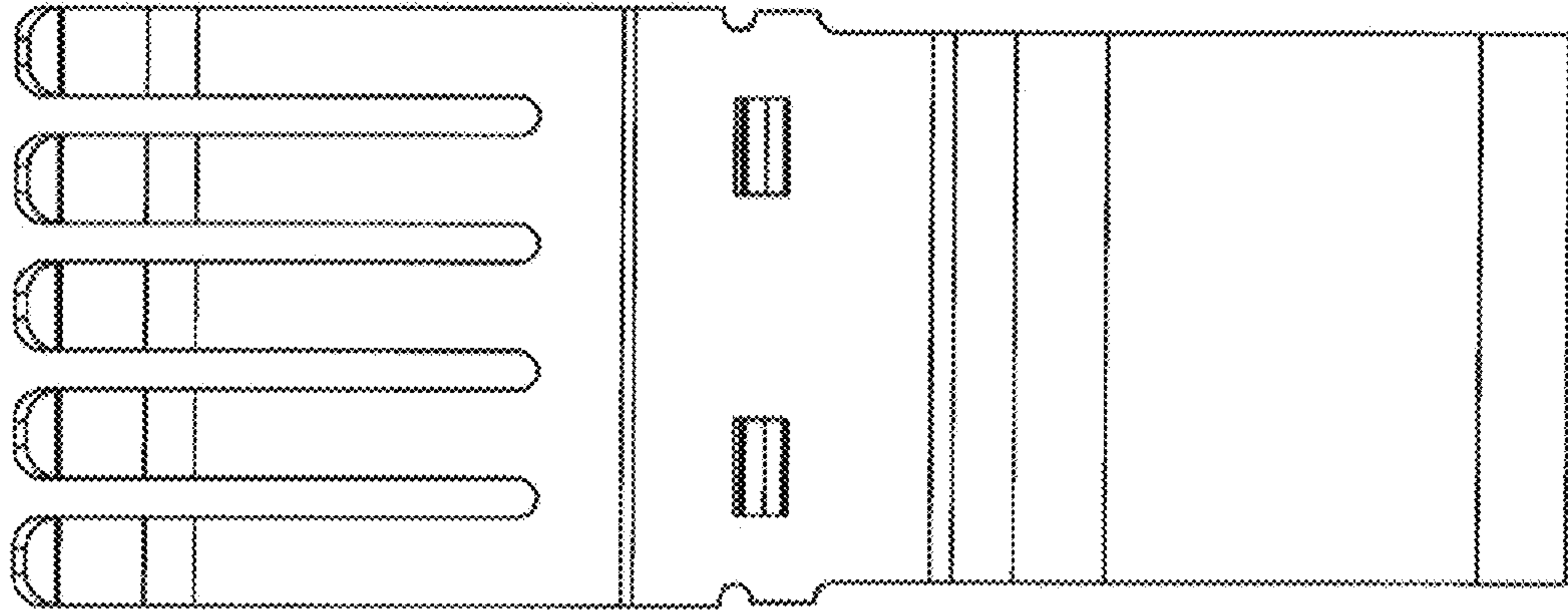

Fig.151

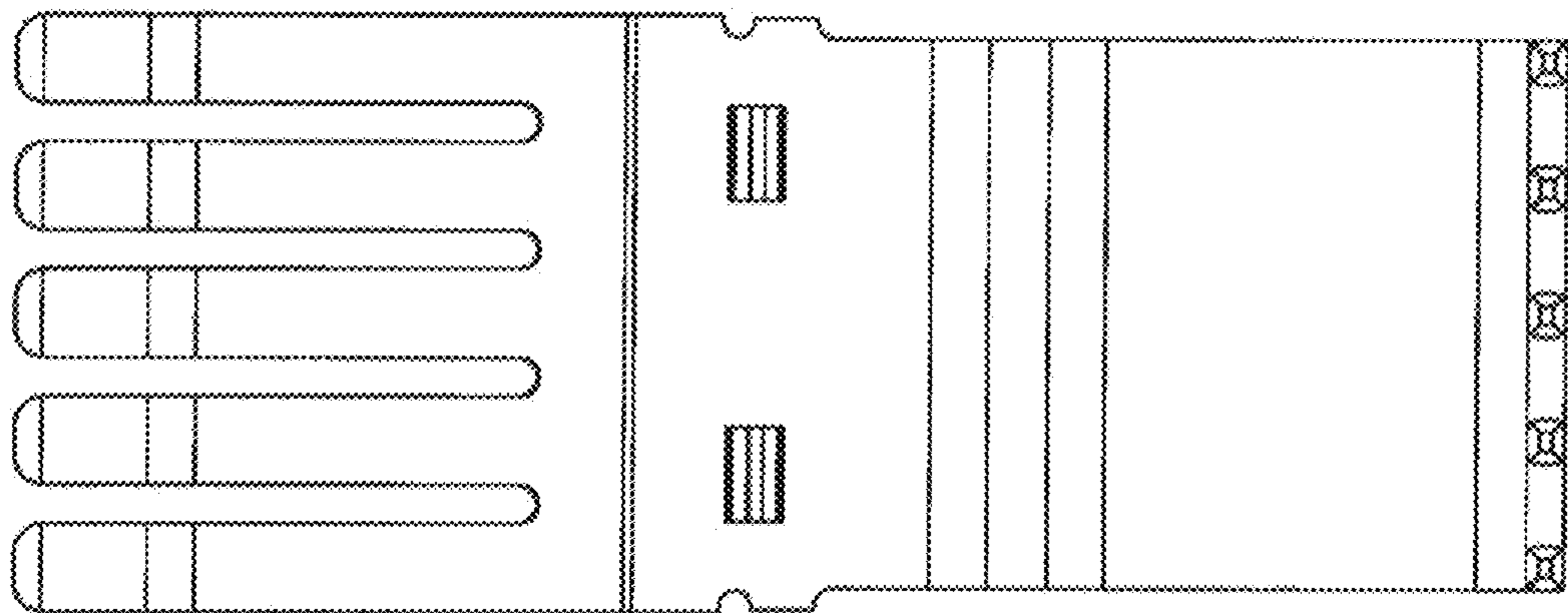

Fig.152

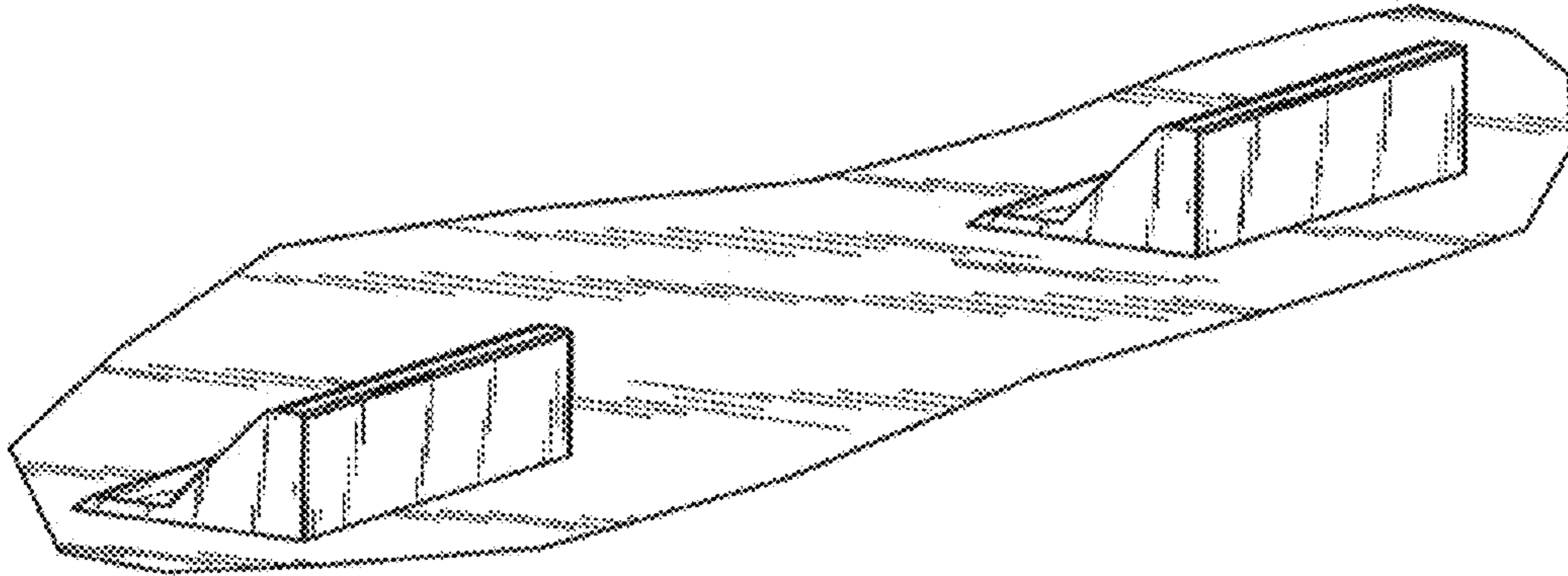

Fig.153

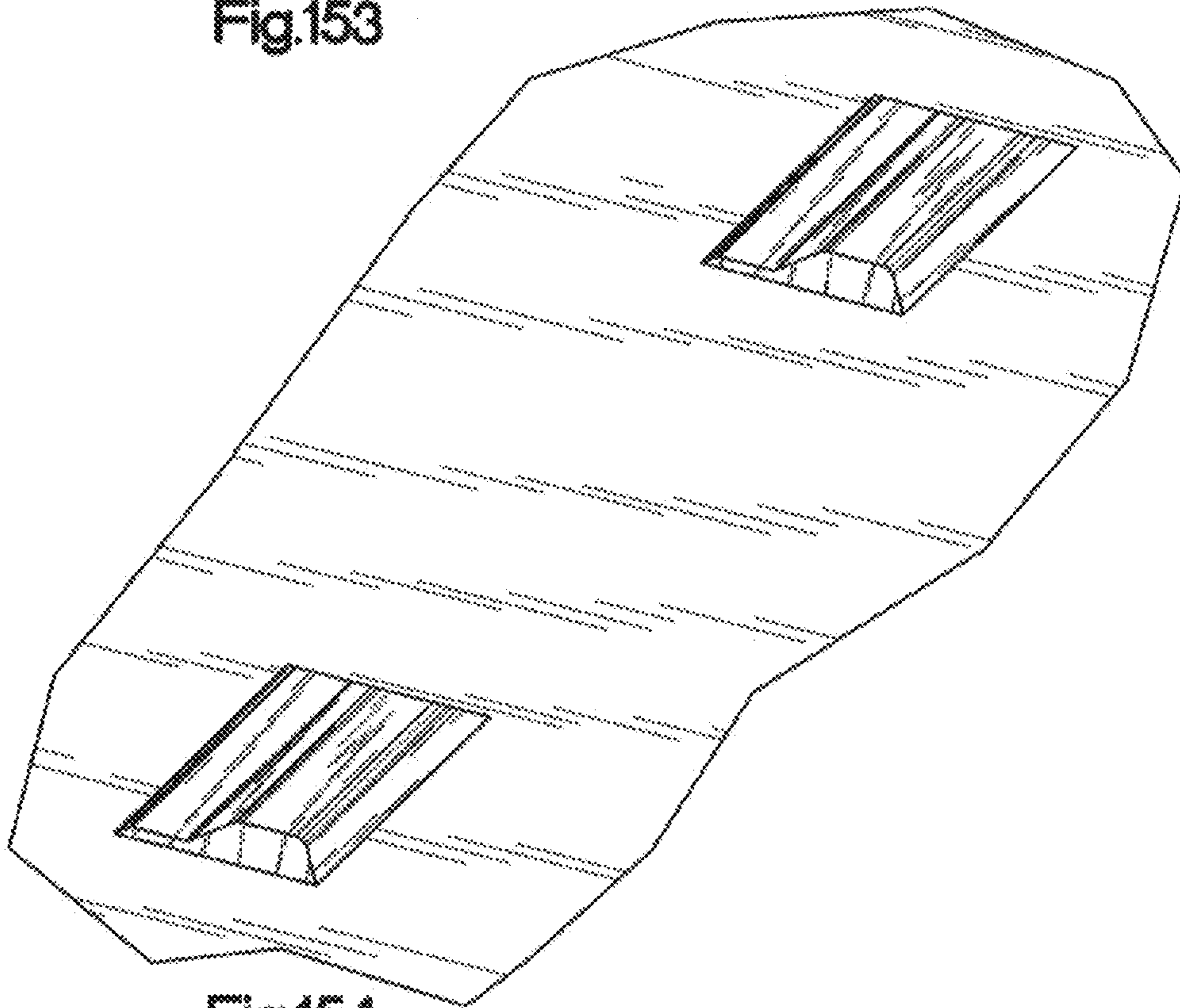

Fig.154

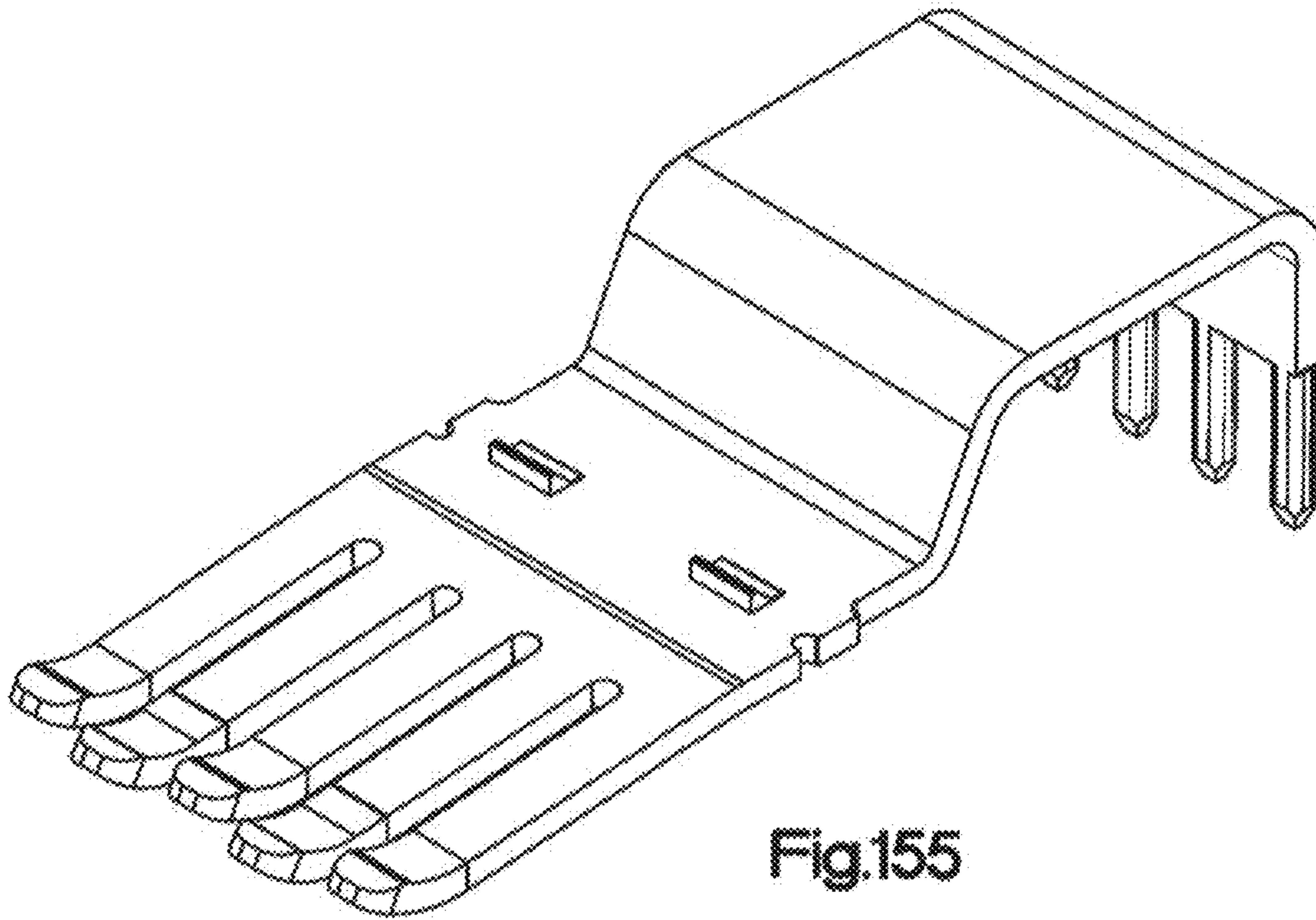

Fig.155

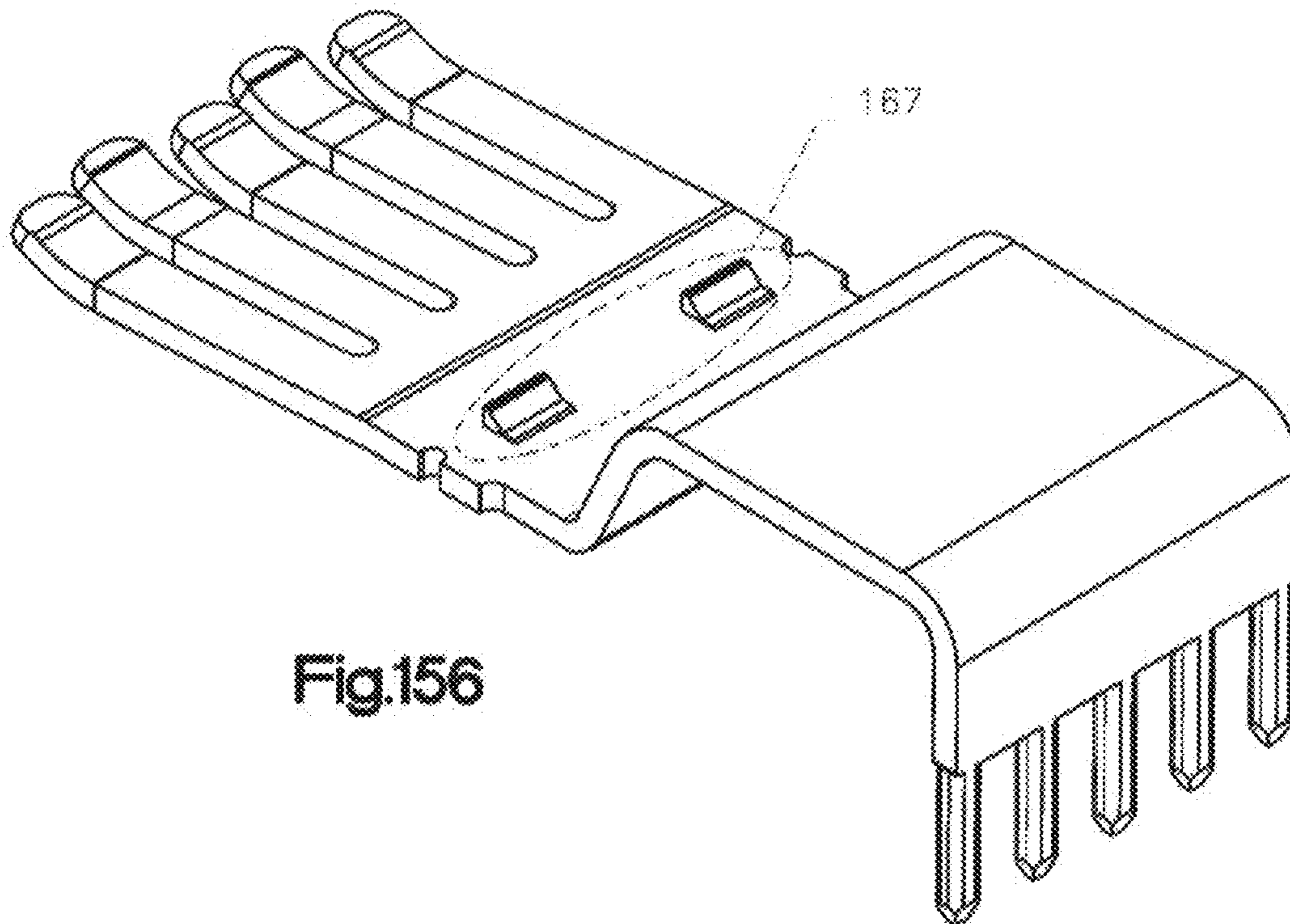

Fig.156

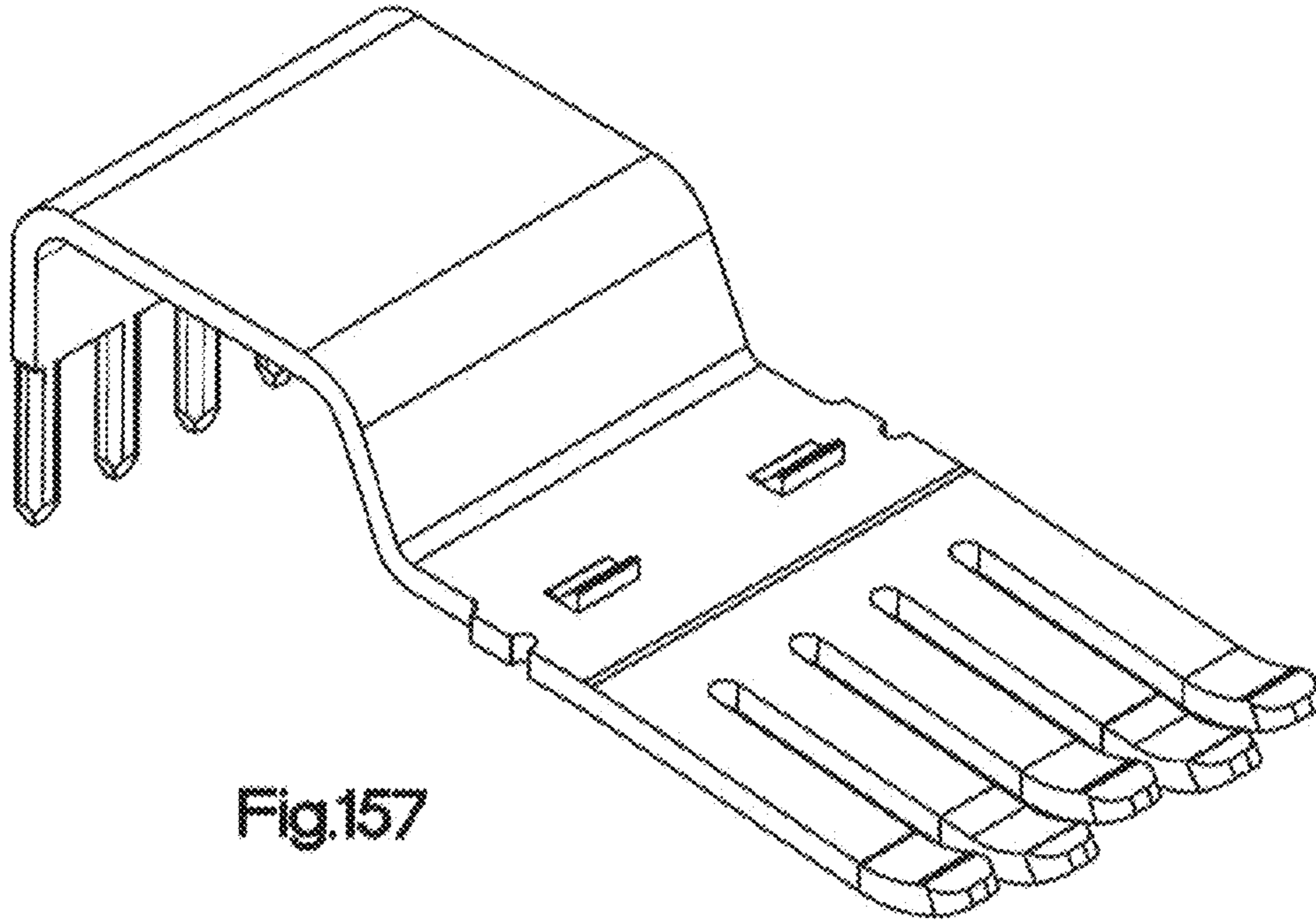

Fig.157

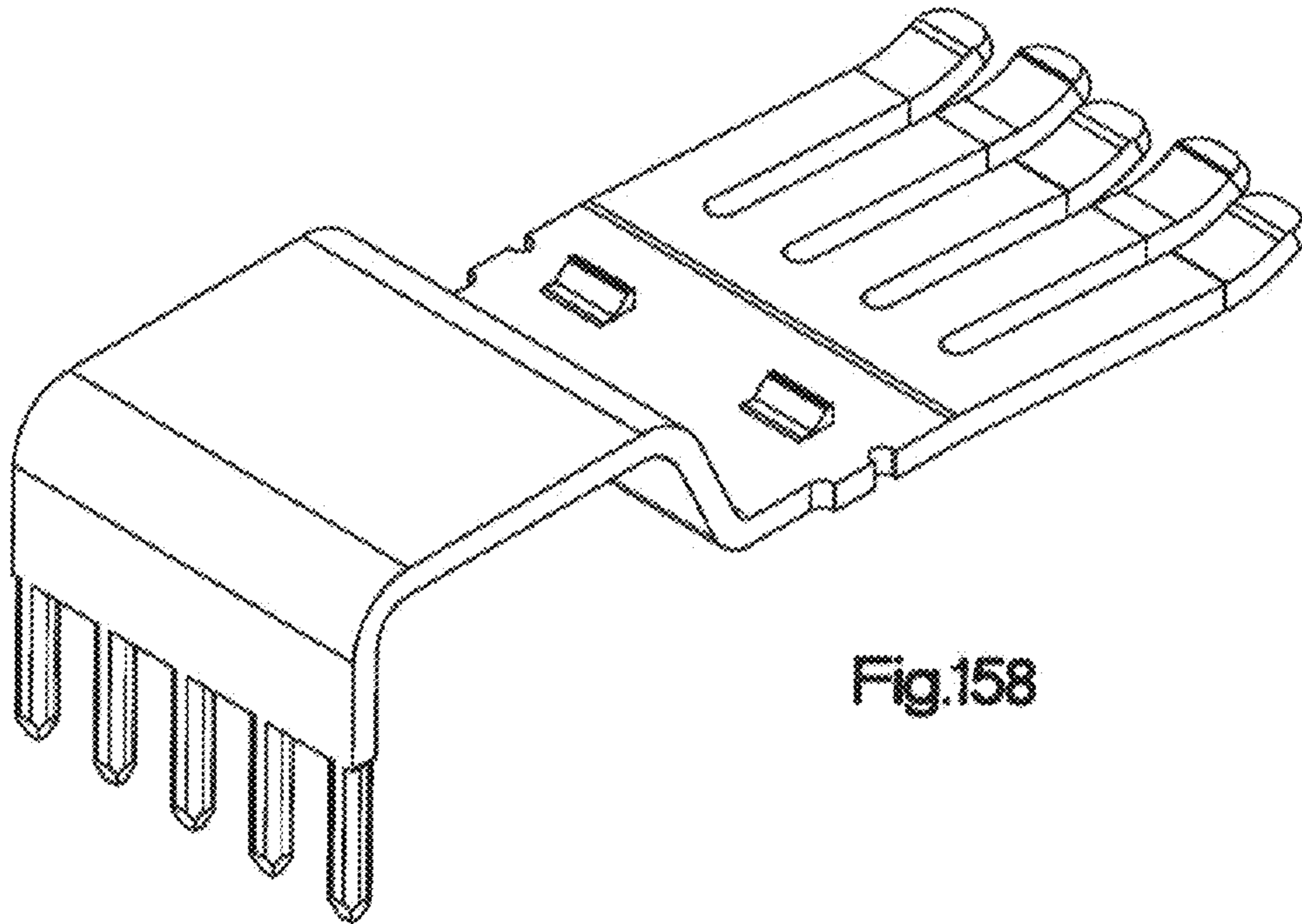
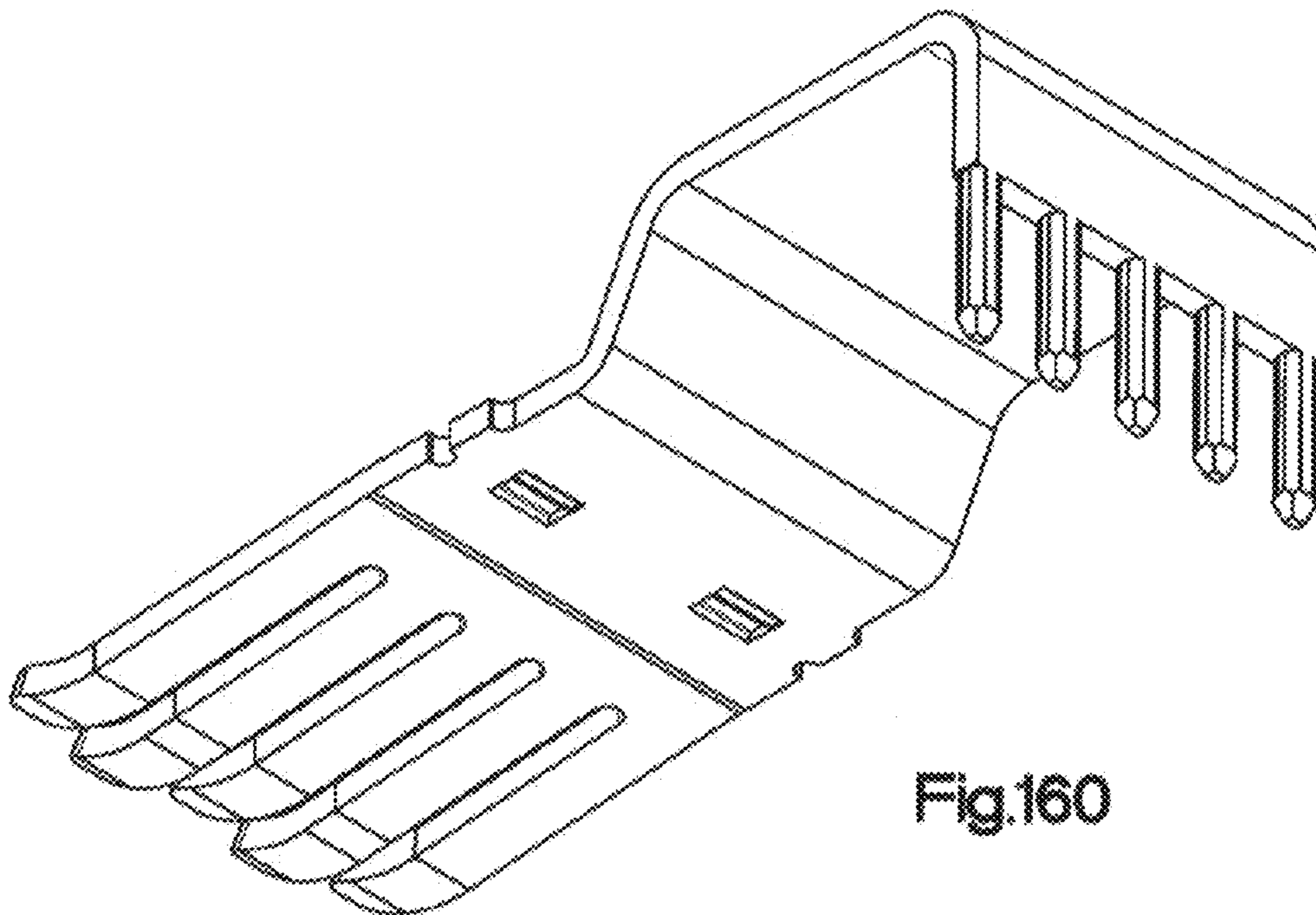
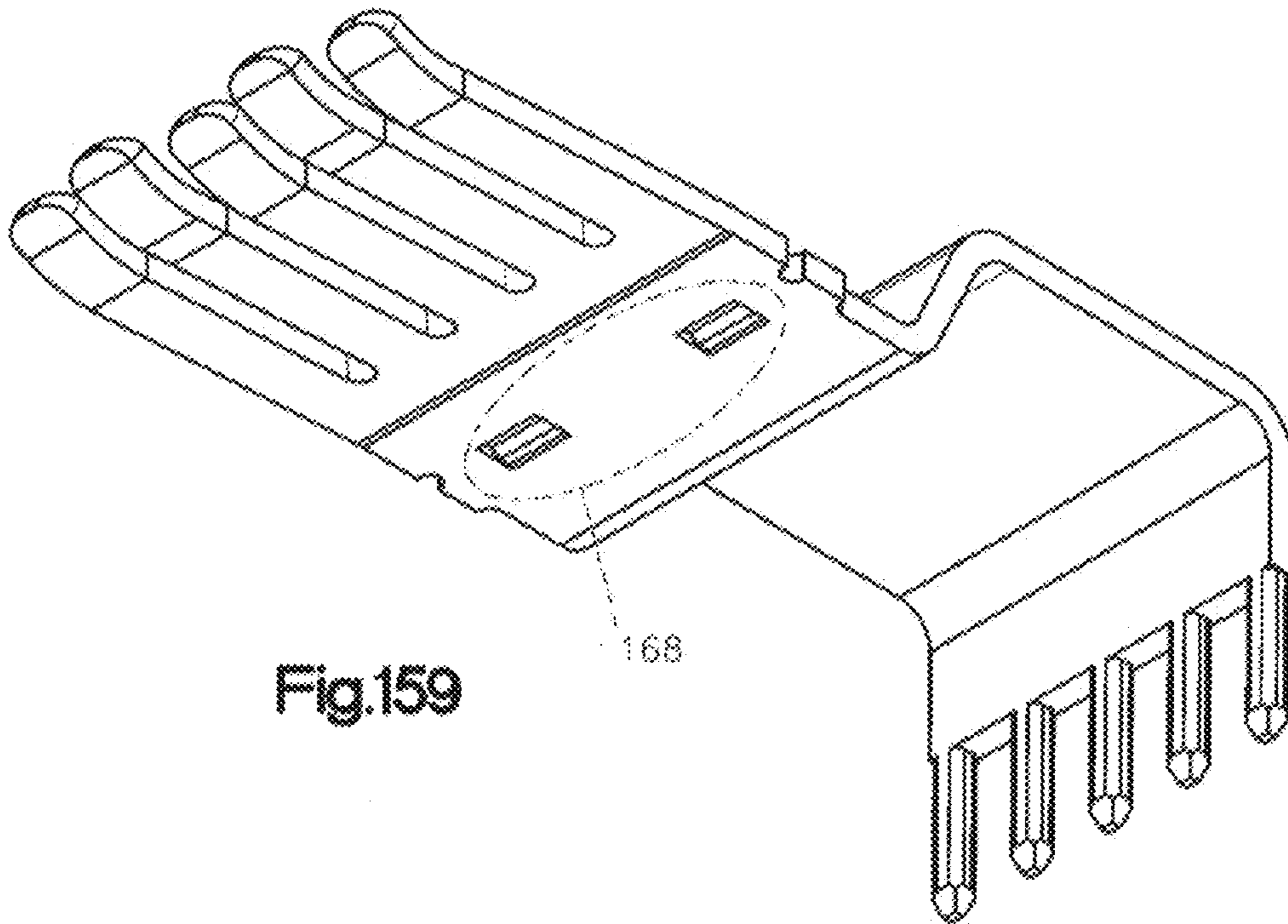

Fig.158



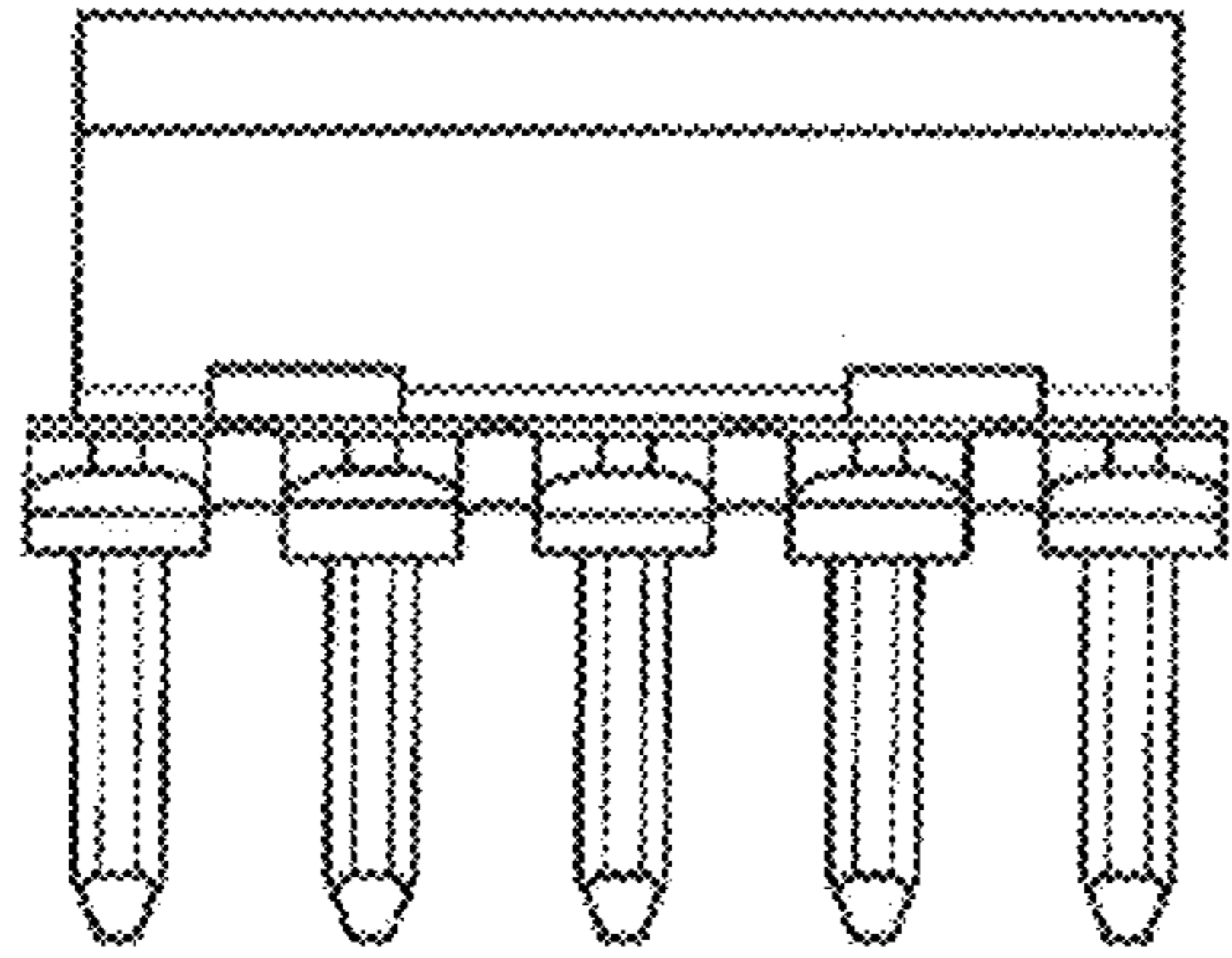

Fig.161

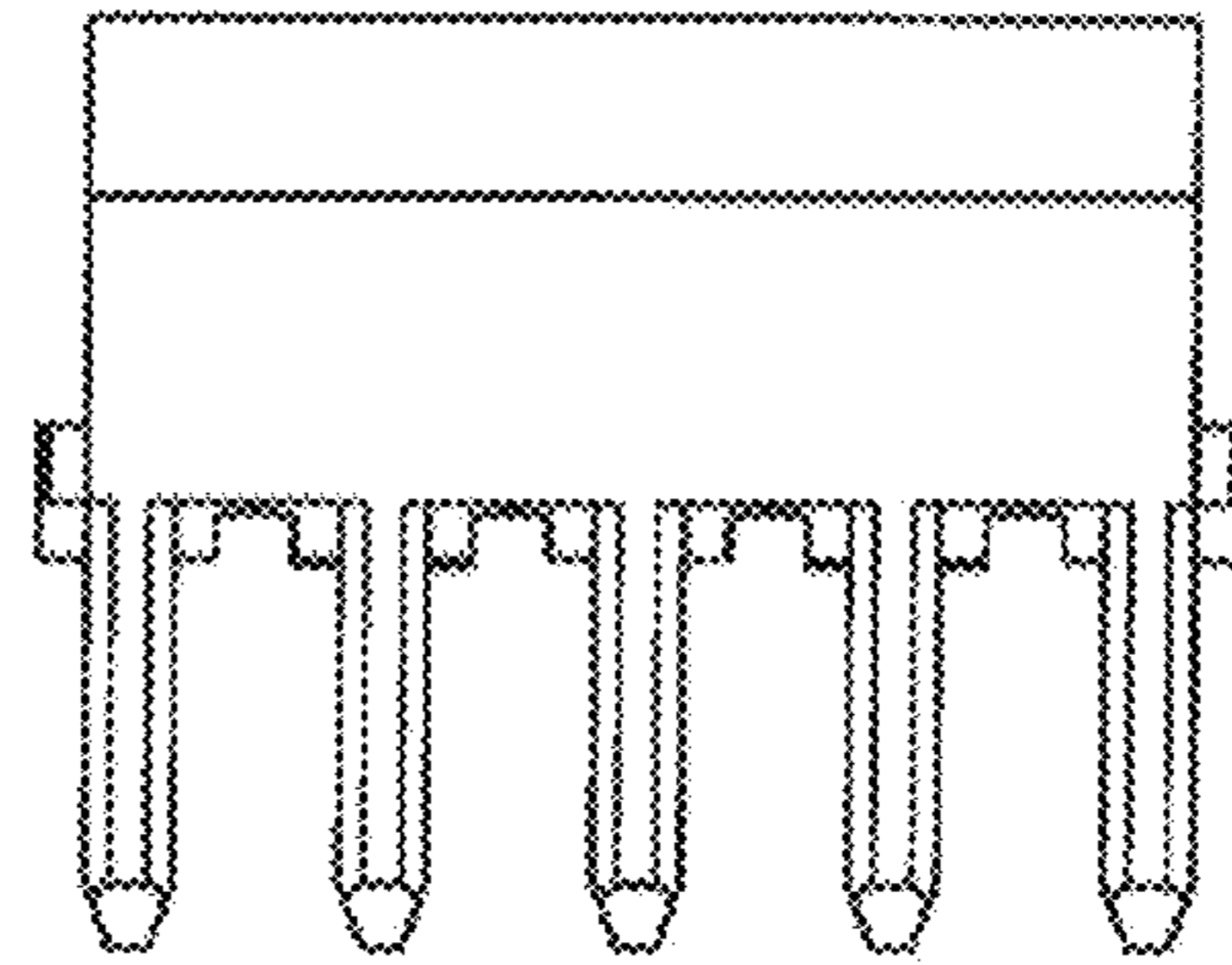

Fig.162

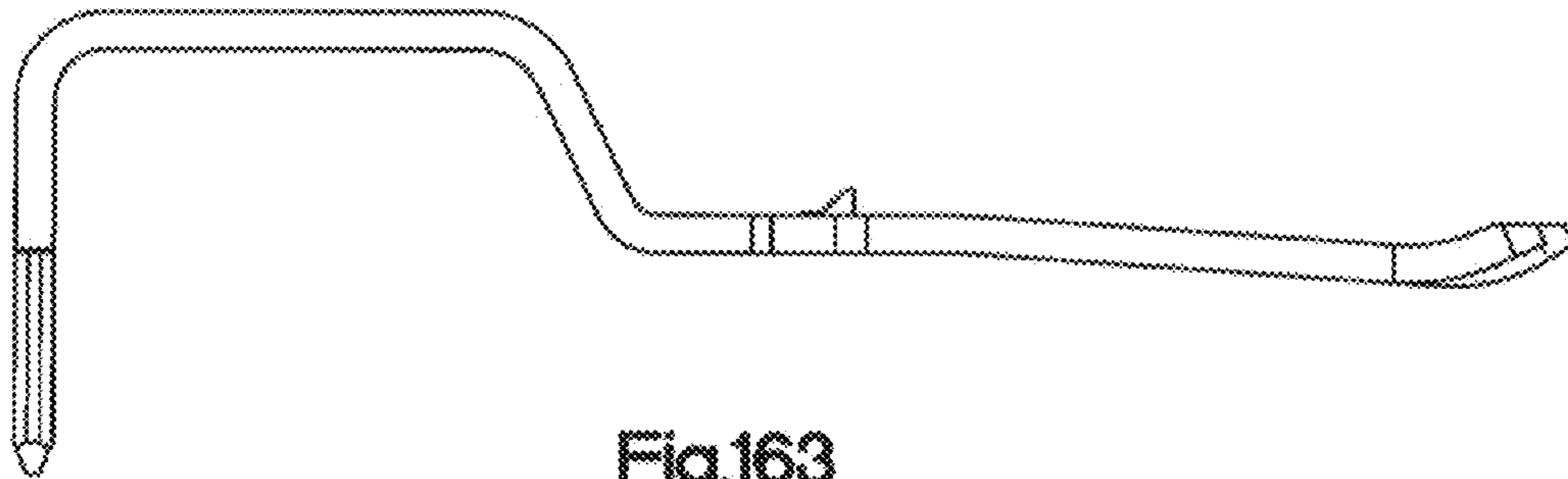

Fig.163

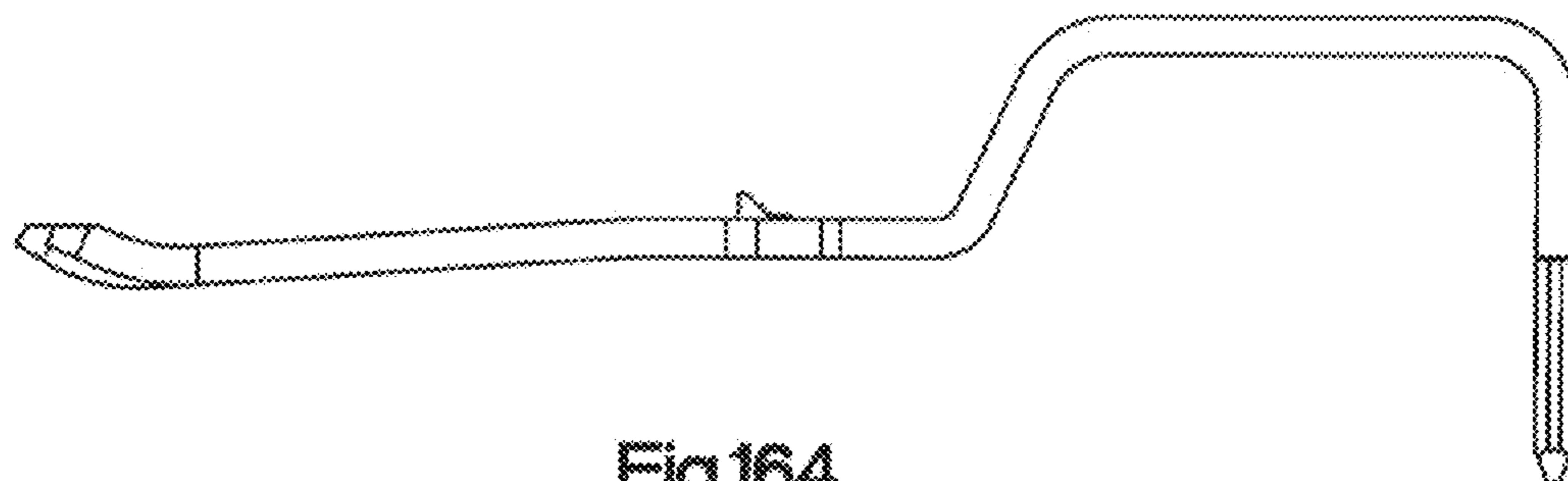

Fig.164

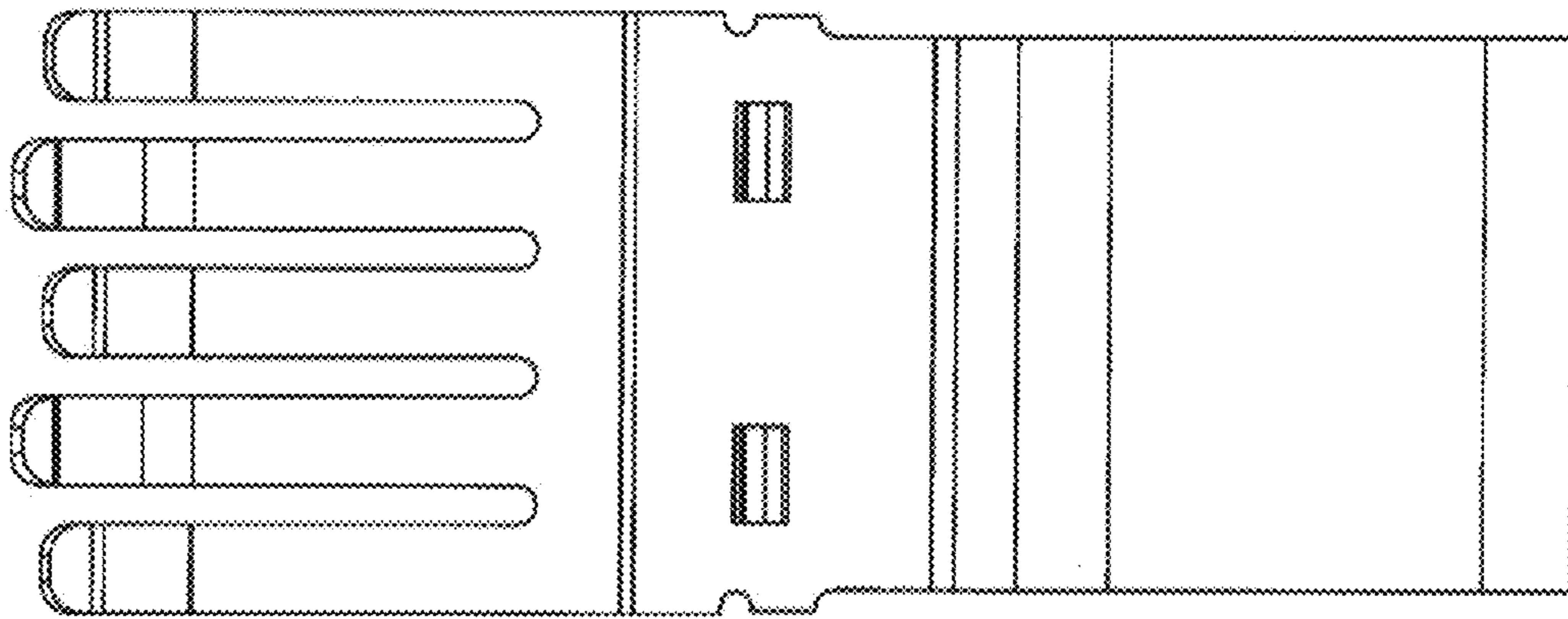

Fig.165

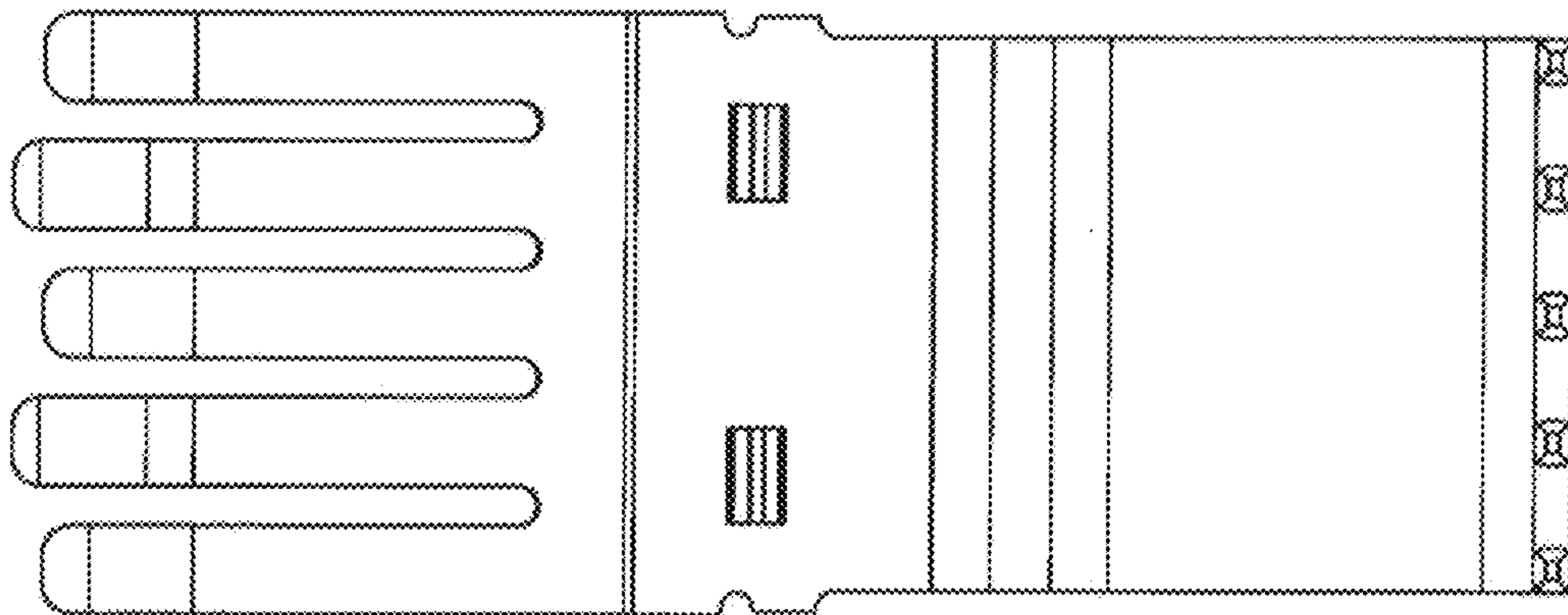

Fig.166

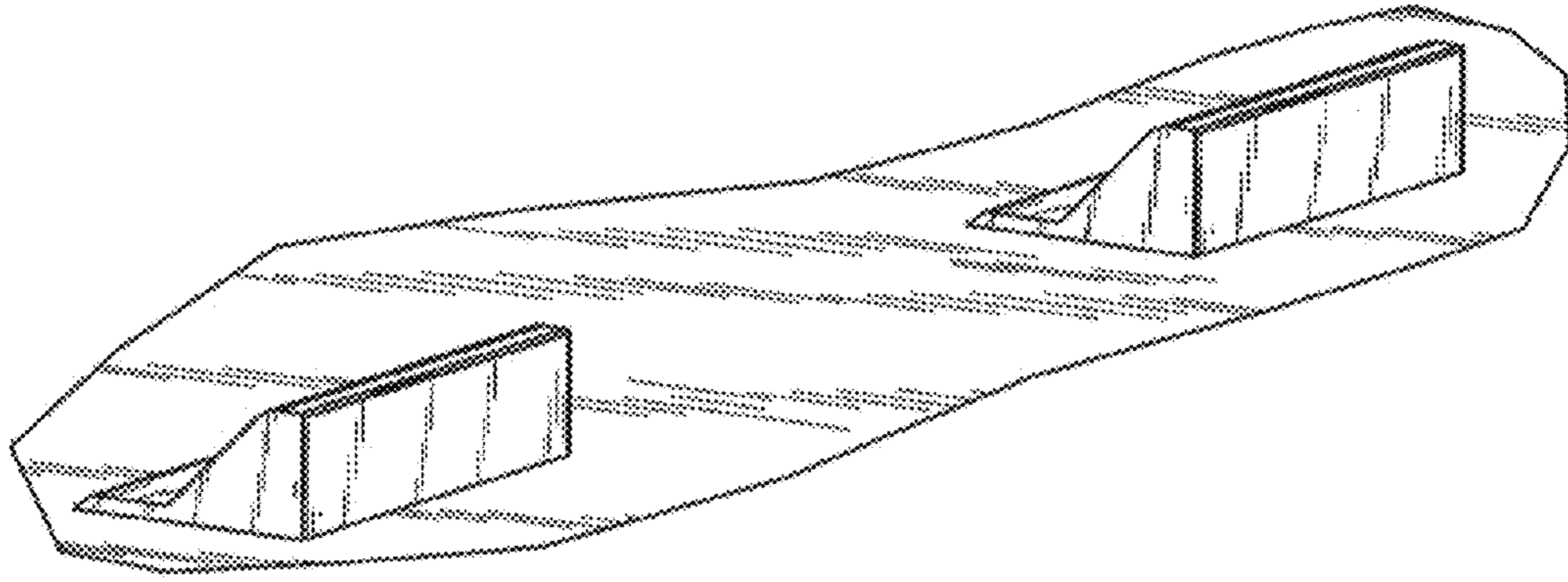

Fig.167

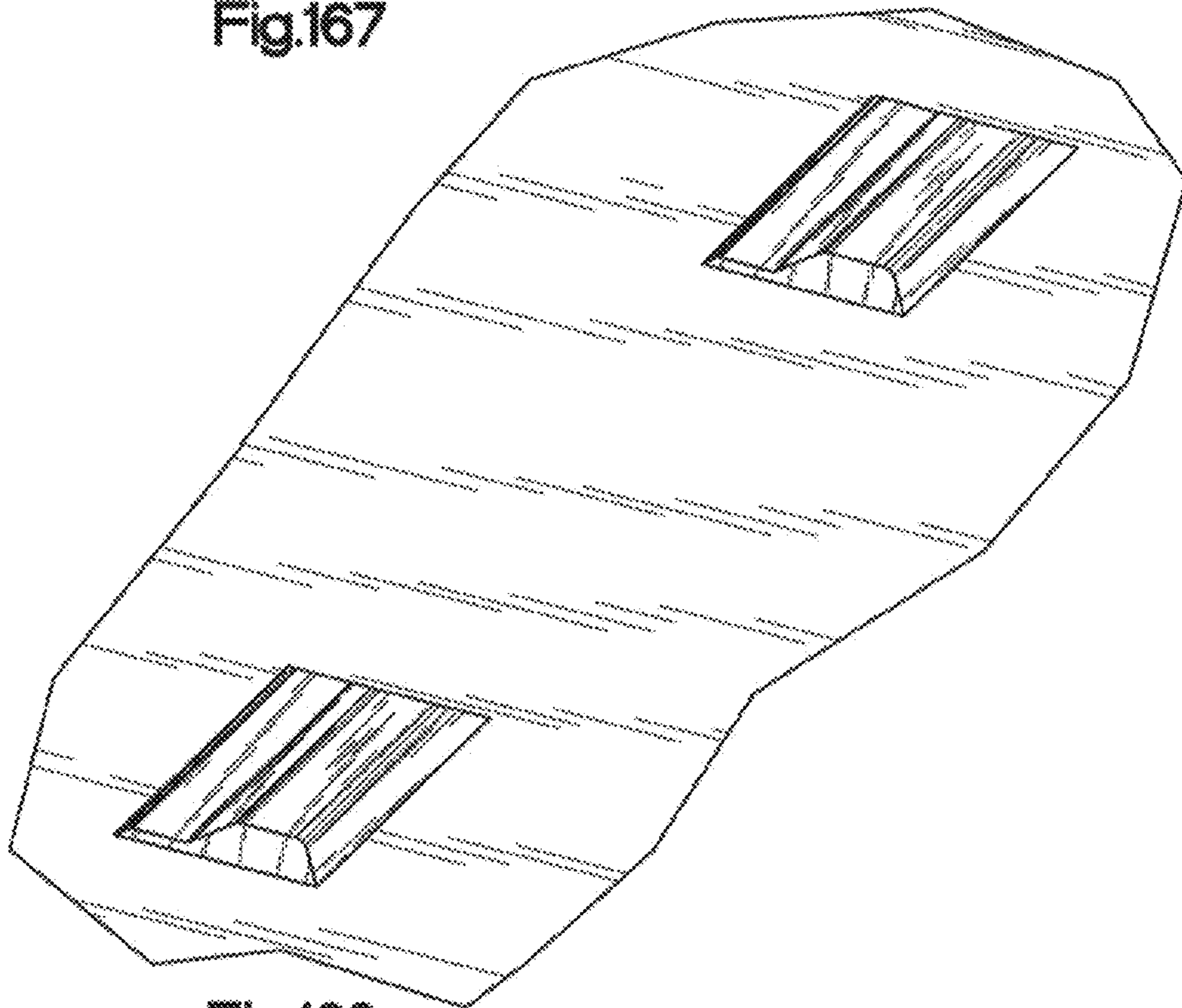

Fig.168