



US00D771542S

(12) **United States Design Patent**
Peat

(10) **Patent No.:** **US D771,542 S**

(45) **Date of Patent:** **** Nov. 15, 2016**

(54) **WHEEL**

(71) Applicant: **Jaguar Land Rover Limited**, Whitley,
Coventry (GB)

(72) Inventor: **Anthony Peat**, Coventry (GB)

(73) Assignee: **Jaguar Land Rover Limited**, Whitley,
Coventry (GB)

(**) Term: **14 Years**

(21) Appl. No.: **29/522,081**

(22) Filed: **Mar. 27, 2015**

(30) **Foreign Application Priority Data**

Sep. 29, 2014 (EM) 002547430

(51) **LOC (10) Cl.** **12-16**

(52) **U.S. Cl.**
USPC **D12/211**

(58) **Field of Classification Search**
USPC D12/204–213
CPC B60B 7/00; B60B 7/02; B60B 7/04;
B60B 7/01; B60B 7/06; B60B 3/02; B60B
3/04; B60B 3/06; B60B 3/10; B60B 1/00;
B60B 1/08; B60B 1/10; B60B 1/12
See application file for complete search history.

(56) **References Cited**

U.S. PATENT DOCUMENTS

D402,951 S	*	12/1998	Wechner	D12/211
D421,953 S	*	3/2000	Sims	D12/211
D432,071 S	*	10/2000	Brown	D12/211
D471,504 S	*	3/2003	Laengerer	D12/211
D479,178 S	*	9/2003	Lai	D12/211
D489,033 S	*	4/2004	Lee	D12/211
D499,686 S	*	12/2004	Song	D12/211
D516,489 S	*	3/2006	Alonso	D12/211

D522,954 S	*	6/2006	Hueller	D12/211
D526,947 S	*	8/2006	Kim	D12/209
D541,203 S	*	4/2007	Sulahian	D12/211
D541,724 S	*	5/2007	Gallert	D12/211
D583,742 S	*	12/2008	Juergens	D12/211
D597,015 S	*	7/2009	Juergens	D12/211
D620,870 S	*	8/2010	Powell	D12/211
D628,136 S	*	11/2010	Leclercq	D12/211
D639,227 S	*	6/2011	Leclercq	D12/211
D666,953 S	*	9/2012	Pollmann	D12/209
D667,769 S	*	9/2012	Pollmann	D12/209
D671,480 S	*	11/2012	Cepkova	D12/209
D671,481 S	*	11/2012	Amezqueta	D12/211
D687,757 S	*	8/2013	Lemke	D12/211
D695,198 S	*	12/2013	Juergens	D12/211
D697,017 S	*	1/2014	Holstein	D12/211
D720,274 S	*	12/2014	Mielke	D12/211
D720,675 S	*	1/2015	Garbas	D12/209
D721,316 S	*	1/2015	Amezqueta	D12/209
D722,002 S	*	2/2015	Stolz	D12/211

(Continued)

Primary Examiner — Stacia Cadmus

(74) *Attorney, Agent, or Firm* — Wood Herron & Evans
LLP

(57) **CLAIM**

The ornamental design for a wheel, as shown and described.

DESCRIPTION

FIG. 1 is a left front perspective view of a wheel according to the invention.

FIG. 2 is a front view of the wheel shown in FIG. 1; and, FIG. 3 is a right side perspective view of the wheel shown in FIG. 1, the left side view being a mirror image thereof. Any elements shown in broken lines form no part of the claimed invention in this application, and are instead included to show environmental aspects of the claimed invention. For example, the broken lines which show the rim, the valve stem hole, the bolt holes, and the center hole form no part of the claimed design.

1 Claim, 2 Drawing Sheets

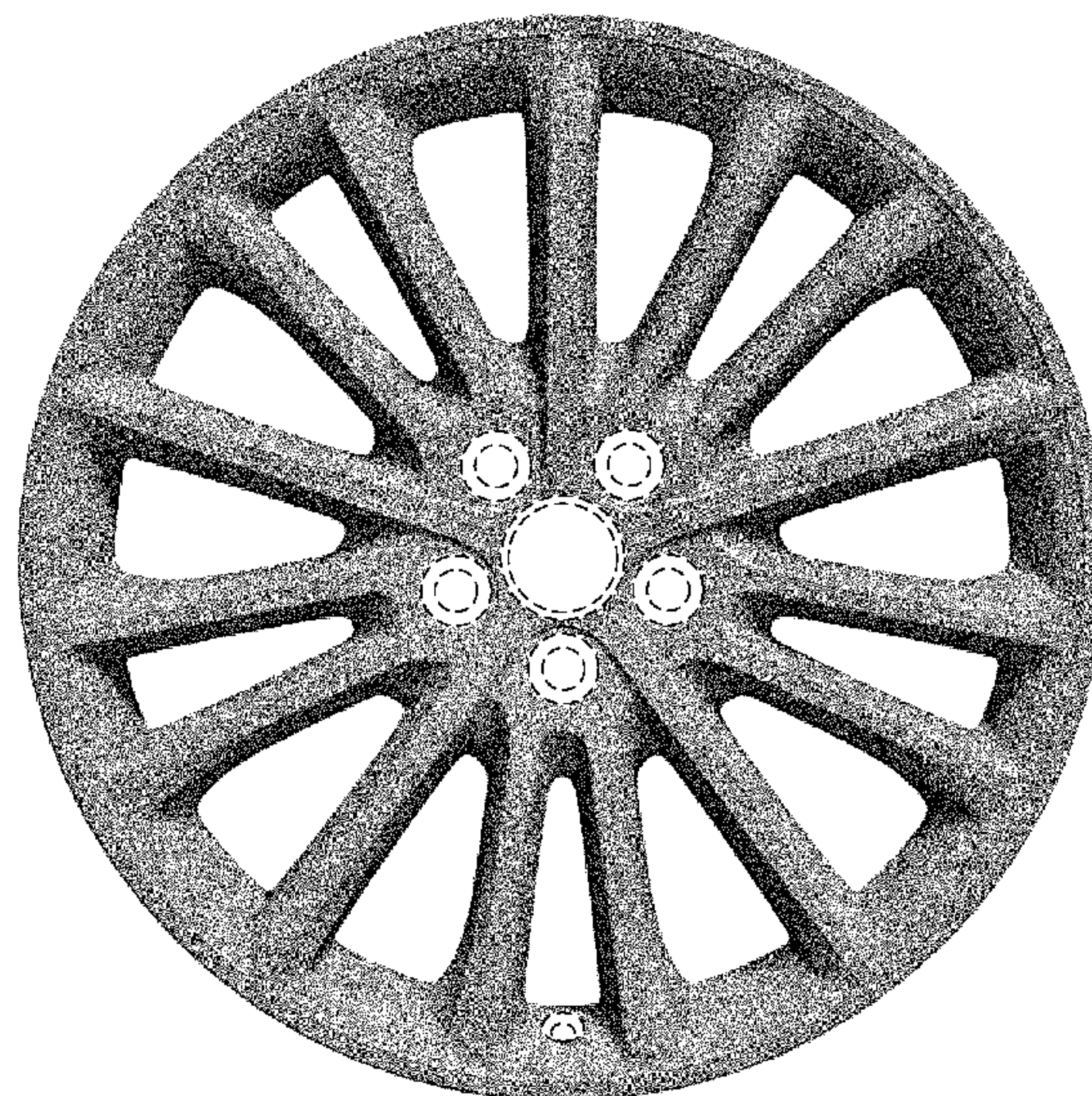
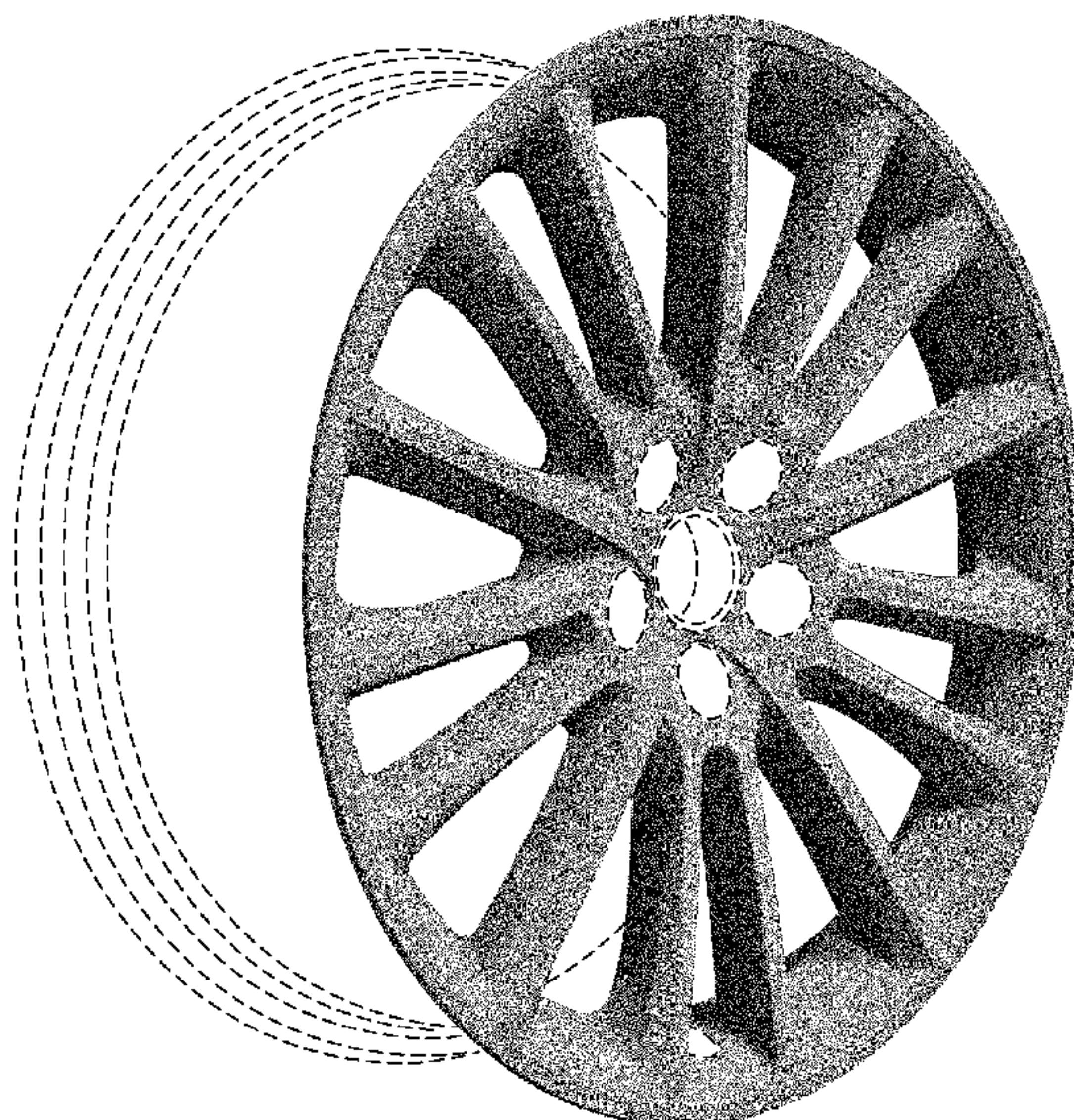

US D771,542 S

Page 2

(56)

References Cited

U.S. PATENT DOCUMENTS

D723,996 S * 3/2015 Zhao D12/211
D726,625 S * 4/2015 Gallert D12/211

D731,388 S * 6/2015 Gotschke D12/211
D746,211 S * 12/2015 Carter D12/211
D754,050 S * 4/2016 Rueckheim D12/211

* cited by examiner

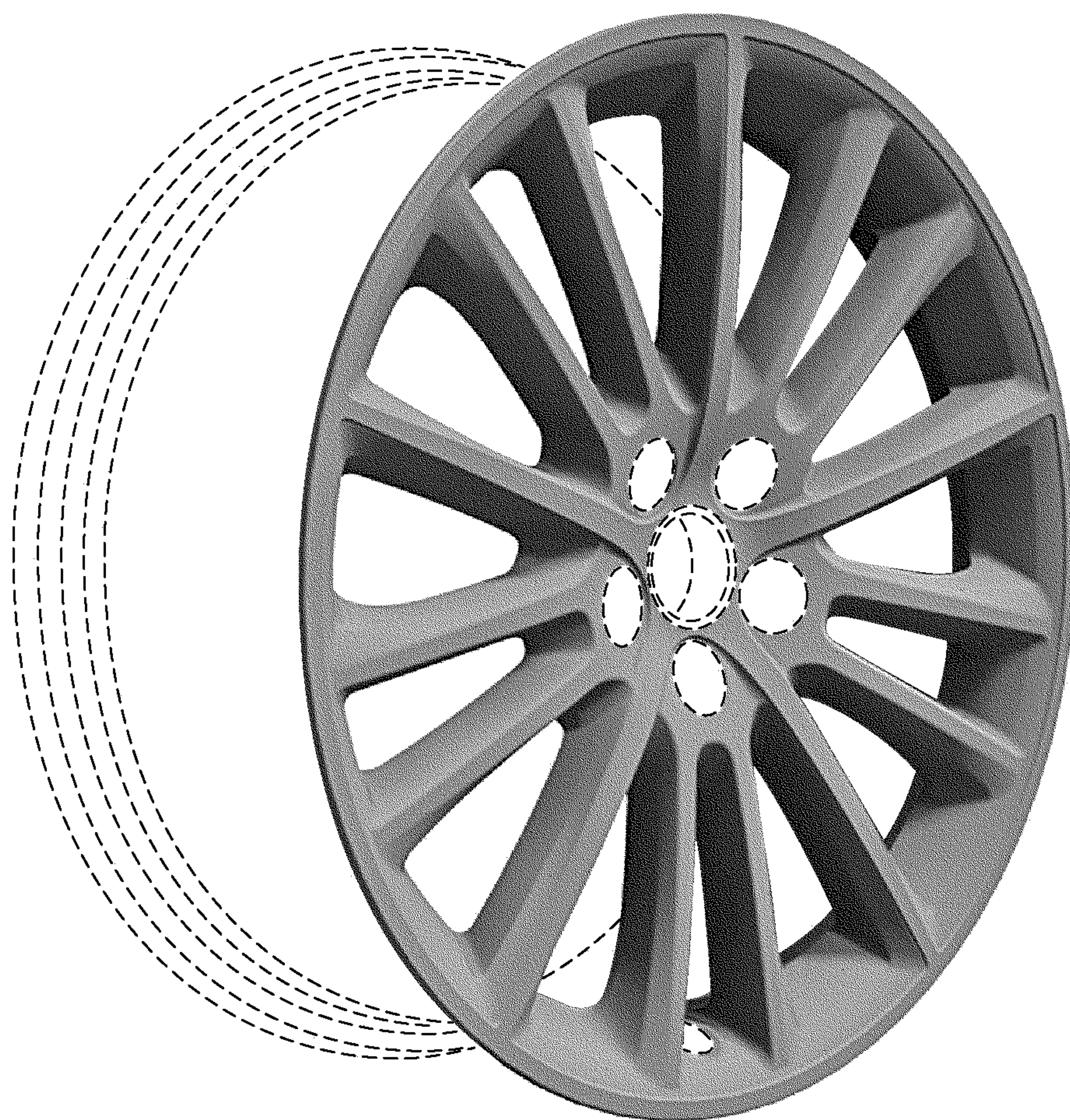

FIG. 1

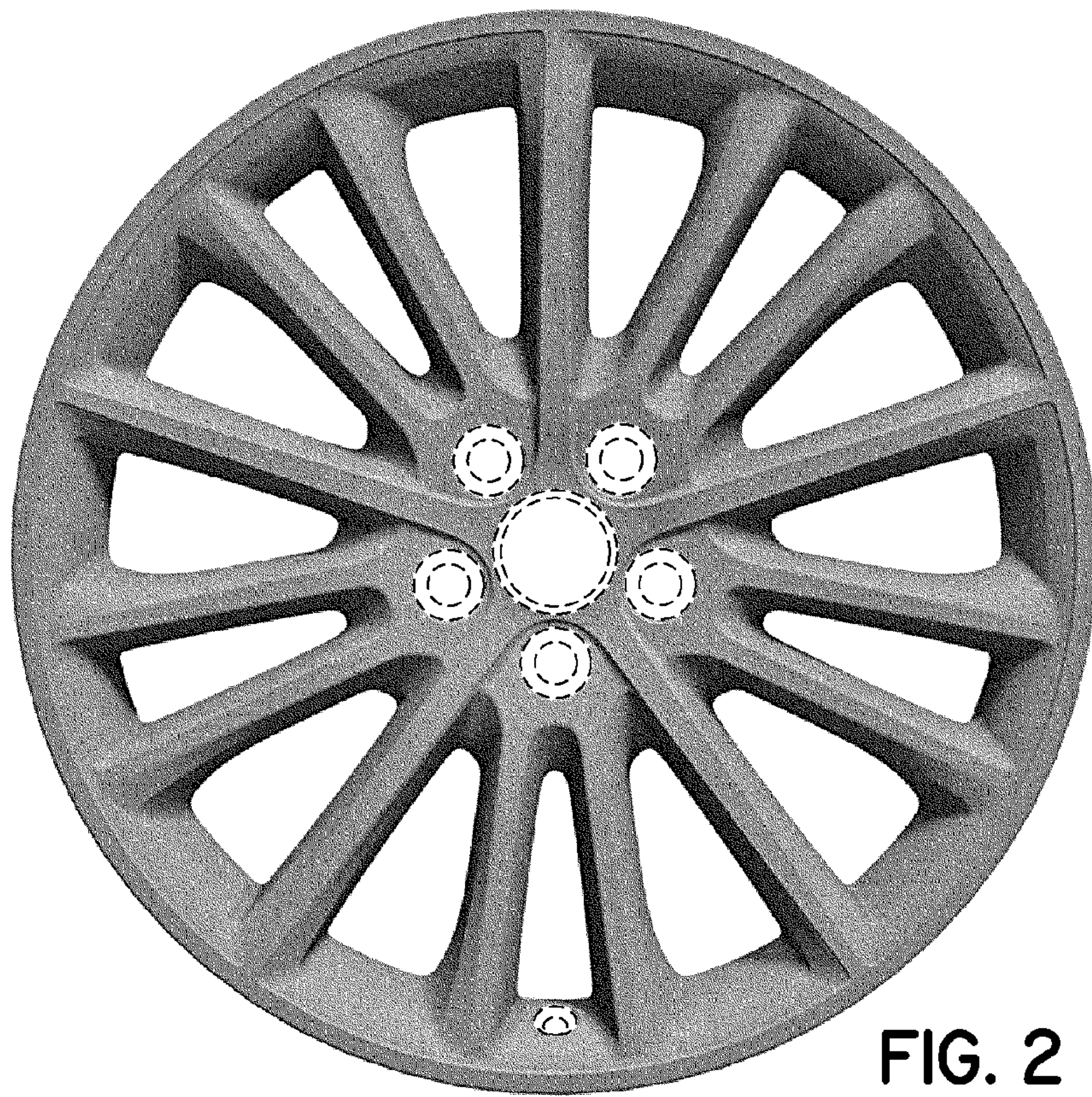

FIG. 2

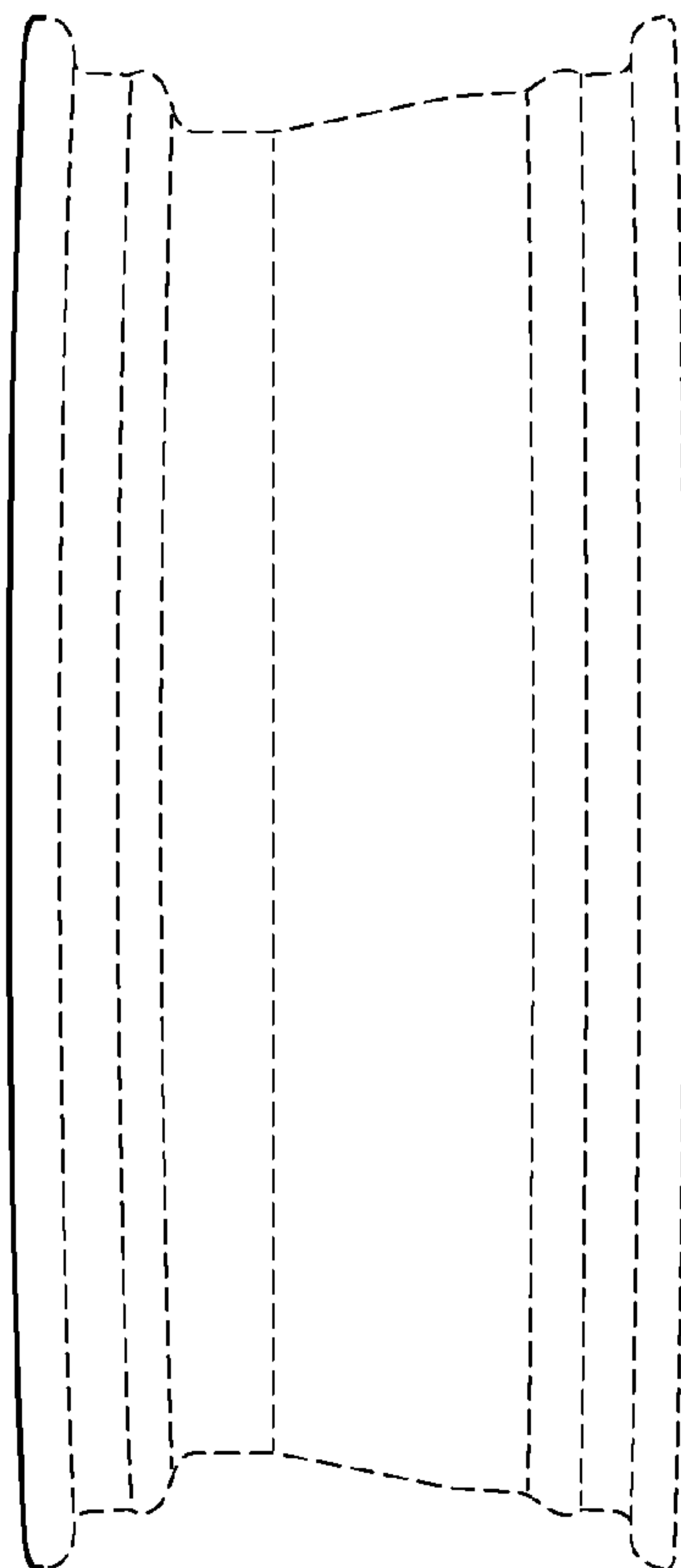

FIG. 3

UNITED STATES PATENT AND TRADEMARK OFFICE
CERTIFICATE OF CORRECTION

PATENT NO. : D771,542 S
APPLICATION NO. : 29/522081
DATED : November 15, 2016
INVENTOR(S) : Anthony Peat

Page 1 of 1

It is certified that error appears in the above-identified patent and that said Letters Patent is hereby corrected as shown below:

On the Title Page

At Column 2, under Description, "FIG. 3 is a right side perspective view of the wheel shown in FIG. 1, the left side view being a mirror image thereof" should read -- FIG. 3 is a right side view of the wheel shown in FIG. 1, the left side view being a mirror image thereof --.

Signed and Sealed this
Ninth Day of May, 2017



Michelle K. Lee
Director of the United States Patent and Trademark Office