



US00D771538S

(12) **United States Design Patent** (10) **Patent No.:** **US D771,538 S**
Brzustowicz et al. (45) **Date of Patent:** **** Nov. 15, 2016**

(54) **FRONT BUMPER END CAP FOR A VEHICLE**

- (71) Applicant: **Daimler AG**, Stuttgart (DE)
- (72) Inventors: **John Brzustowicz**, Portland, OR (US);
Donald Vena, Vancouver, WA (US);
Paul Shead, Beaverton, OR (US)
- (73) Assignee: **Daimler AG**, Stuttgart (DE)
- (**) Term: **14 Years**
- (21) Appl. No.: **29/510,238**
- (22) Filed: **Nov. 26, 2014**
- (30) **Foreign Application Priority Data**

May 27, 2014 (EM) 002471250-0002

(51) **LOC (10) Cl.** **12-16**

(52) **U.S. Cl.**
USPC **D12/172; D12/196**

(58) **Field of Classification Search**
USPC D12/86, 90, 91, 92, 93, 96, 97, 163,
D12/169, 171, 172, 173, 196, 216; 293/102,
293/114, 115, 117, 119, 120, 142, 149, 154
CPC B60R 19/02; B60R 19/04; B62D 25/08
See application file for complete search history.

(56) **References Cited**

U.S. PATENT DOCUMENTS

D422,957 S	*	4/2000	Damon	D12/196
D433,980 S	*	11/2000	Conway	D12/196
D434,358 S	*	11/2000	Conway	D12/196
D435,813 S	*	1/2001	Johnson	D12/167
D531,946 S	*	11/2006	Angelo	D12/196
D567,725 S	*	4/2008	Spearman-Oxx	D12/169
D580,317 S	*	11/2008	Gueler	D12/169
D593,467 S	*	6/2009	Golden	D12/184
D619,068 S	*	7/2010	Beigel	D12/196
D669,826 S	*	10/2012	Svensson	D12/169
D694,679 S	*	12/2013	Campbell	D12/169
D702,606 S	*	4/2014	Conway	D12/184
D707,607 S	*	6/2014	Leetz	D12/196

OTHER PUBLICATIONS

“Transformers 4: Meet the upgraded Optimus Prime, new Autobots,” Hero Complex, Los Angeles Times, May 30, 2013.
“Western Star Introduces the All-New 5700XE,” Western Star Trucks Press Releases, Daimler Trucks North America, Sep. 11, 2014.

* cited by examiner

Primary Examiner — Robert M Spear
Assistant Examiner — Kendra L Hamilton

(74) *Attorney, Agent, or Firm* — Crowell & Moring LLP

(57) **CLAIM**

The ornamental design for a front bumper end cap for a vehicle, as shown and described.

DESCRIPTION

This application contains subject matter related to the following co-pending U.S. design patent application: Application Ser. No. 29/509,784, filed Nov. 21, 2014 and entitled “Vehicle, Toy, and/or Replicas Thereof.”

FIG. 1 is a right front perspective view of a first embodiment of a front bumper end cap for a vehicle according to the design;

FIG. 2 is a front view thereof;

FIG. 3 is a right side view thereof;

FIG. 4 is a top view thereof; and

FIG. 5 is a bottom view thereof.

FIG. 6 is a left front perspective view of a second embodiment of the front bumper end cap for a vehicle according to the design;

FIG. 7 is a front view thereof;

FIG. 8 is a left side view thereof;

FIG. 9 is a top view thereof; and

FIG. 10 is a bottom view thereof.

In the drawings, the broken lines depict environmental subject matter only and form no part of the claimed design.

1 Claim, 4 Drawing Sheets

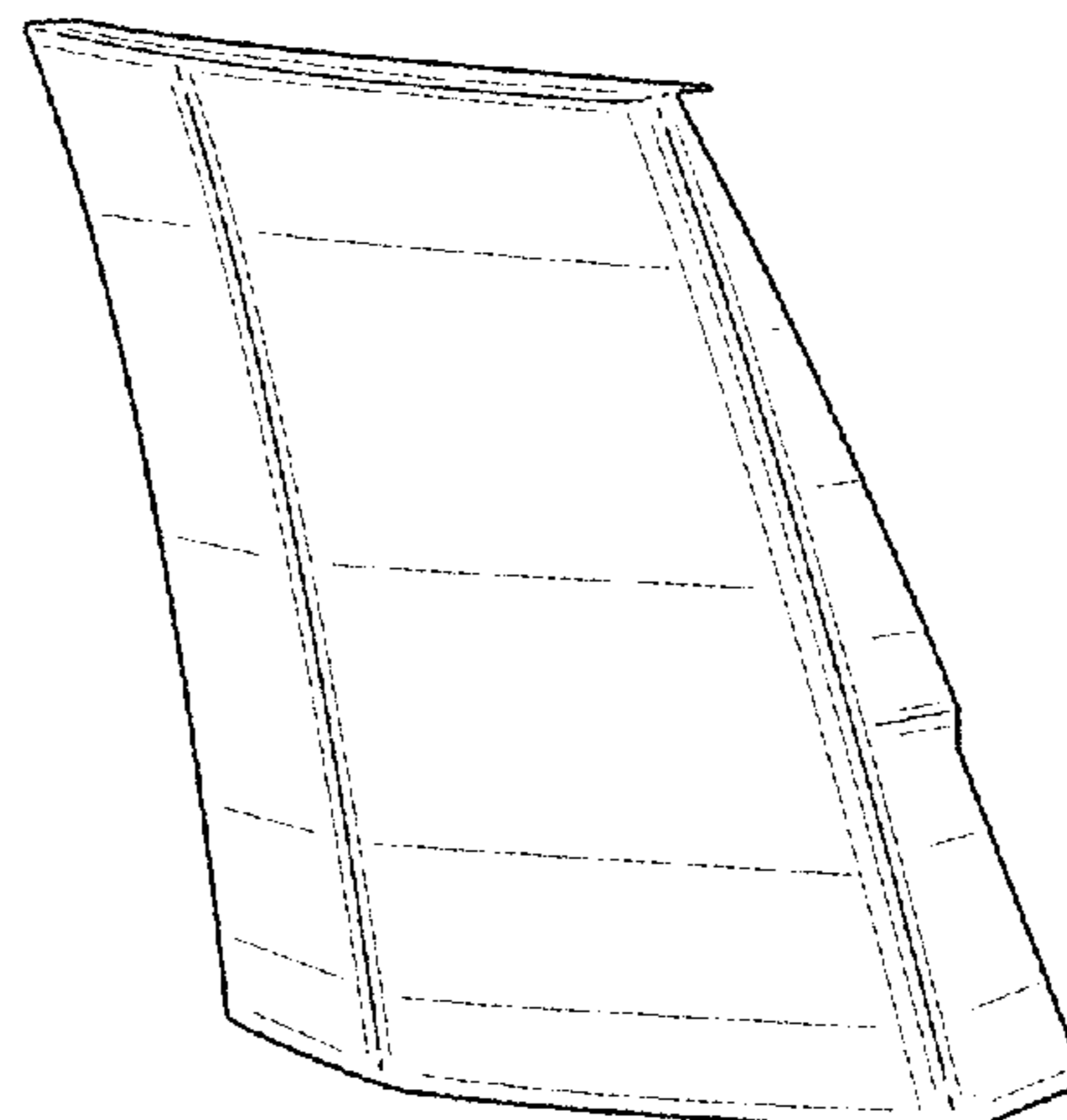
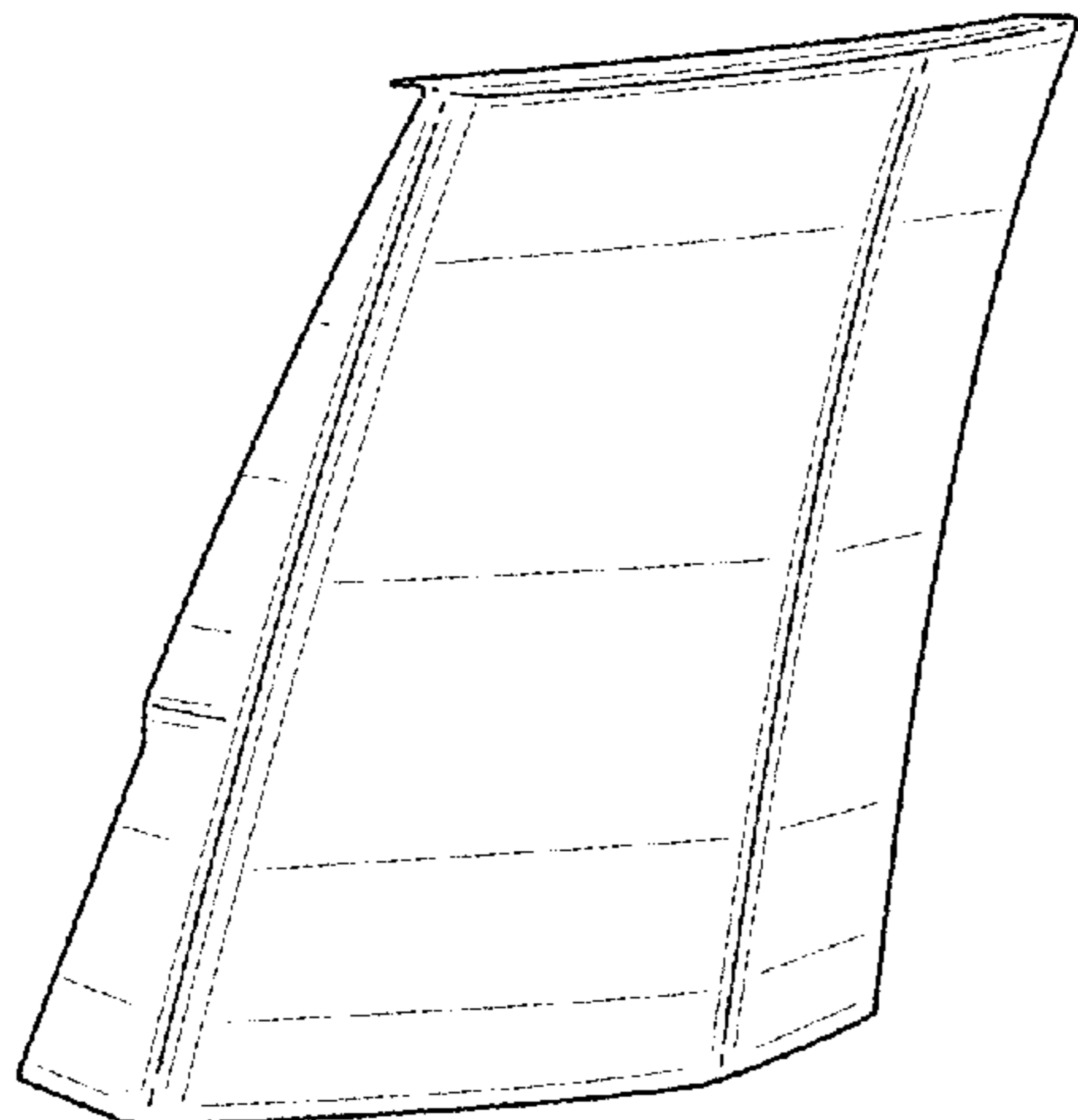

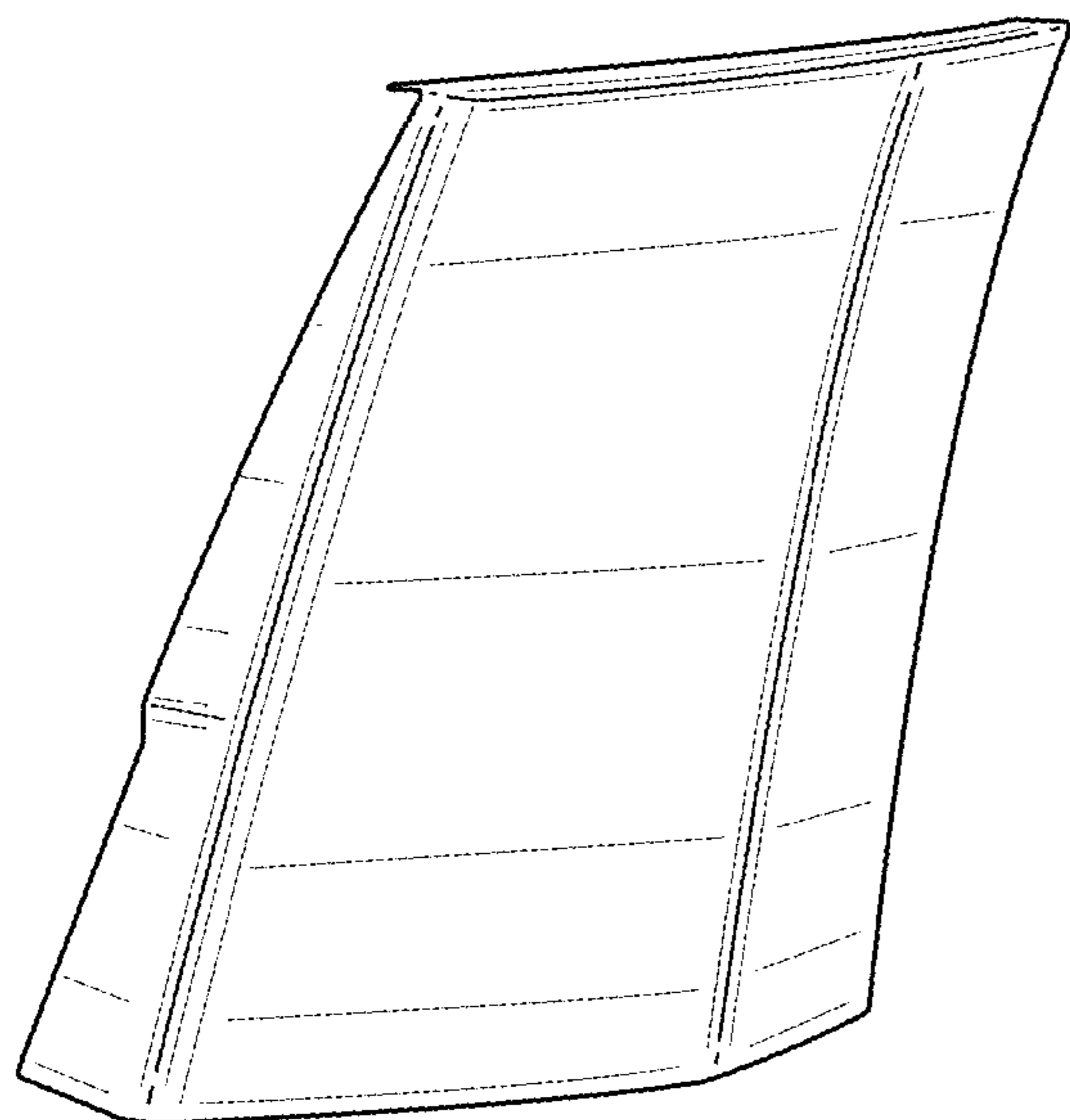

FIG. 1

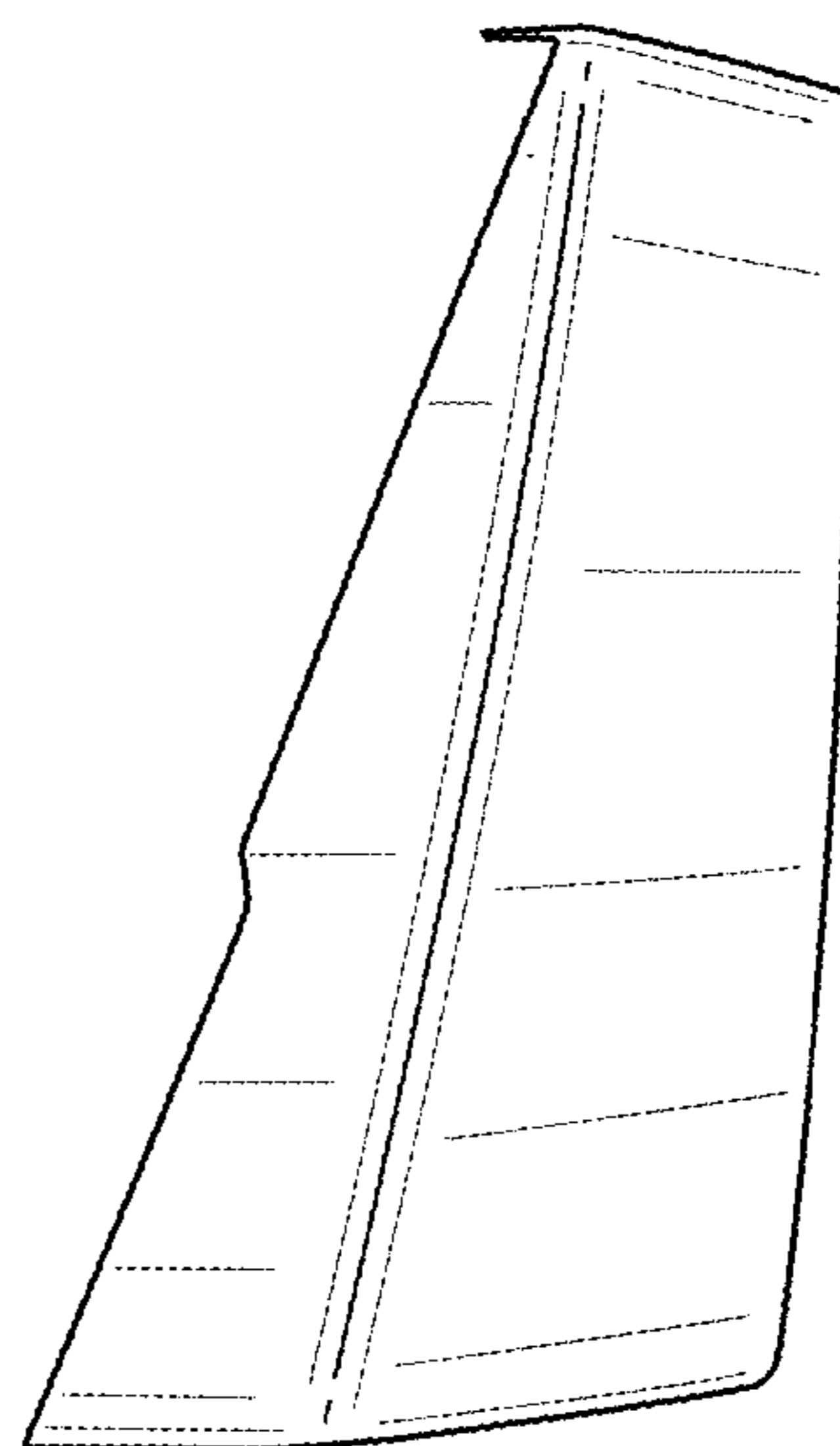

FIG. 2

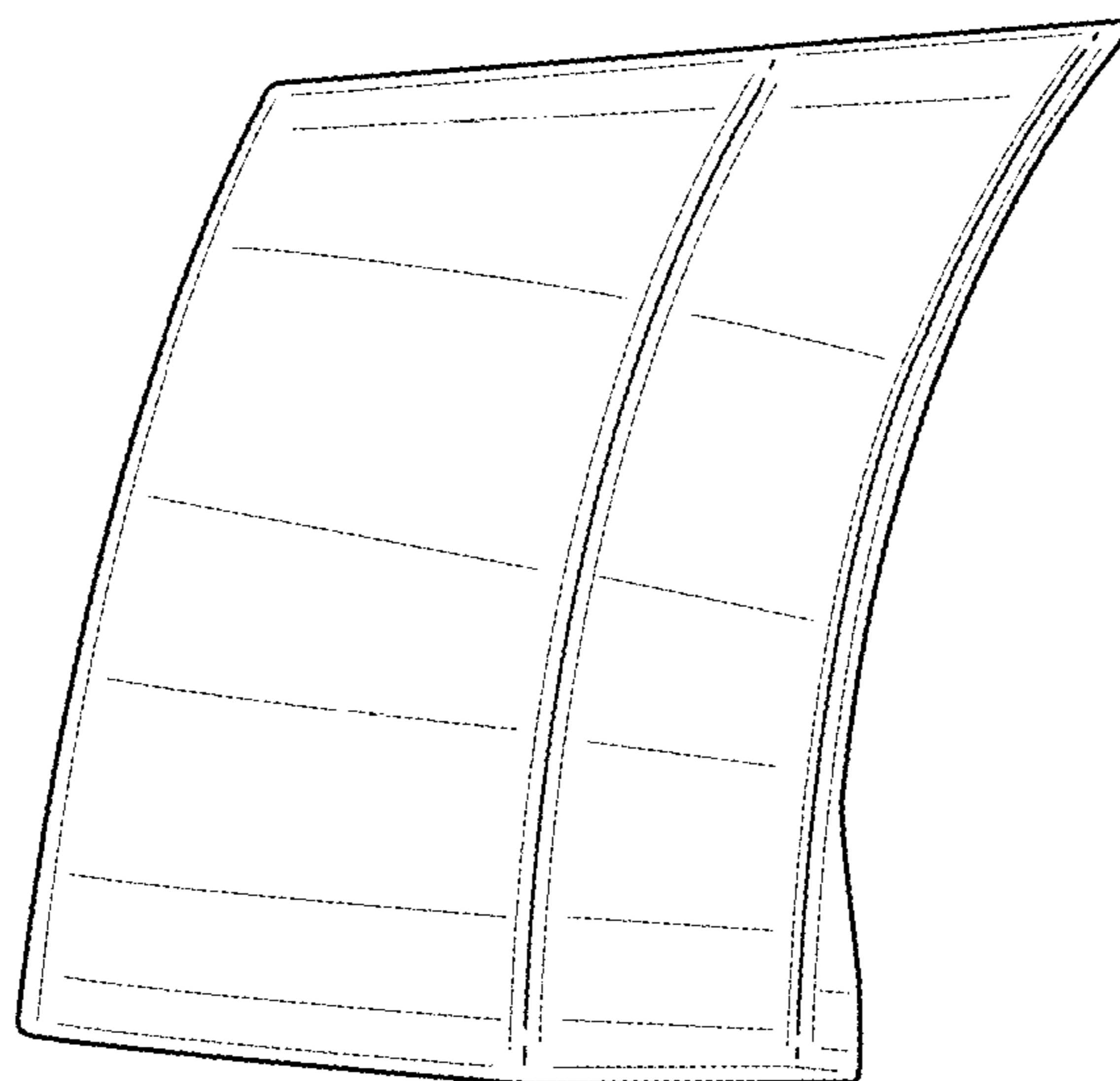

FIG. 3

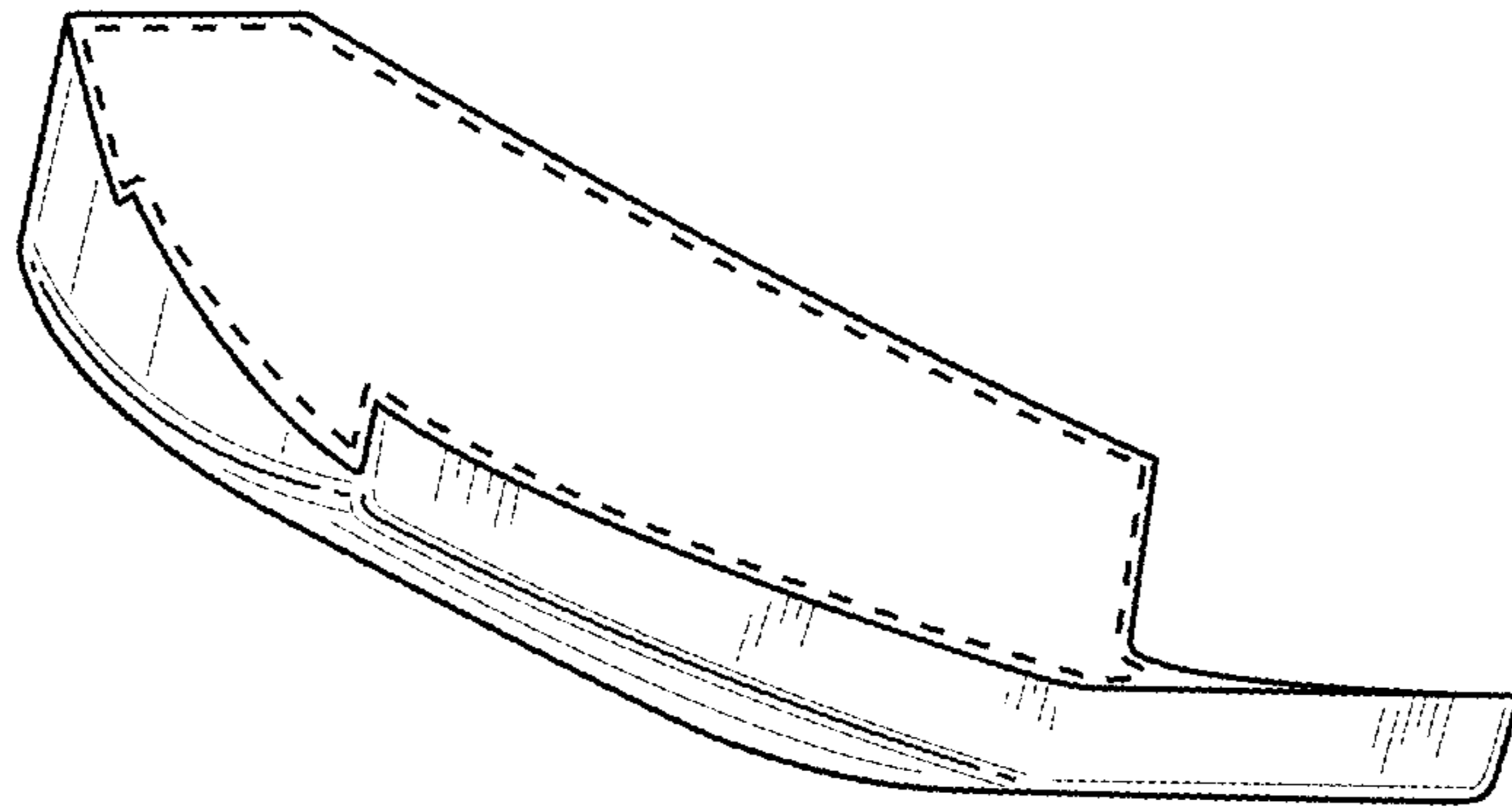

FIG. 4

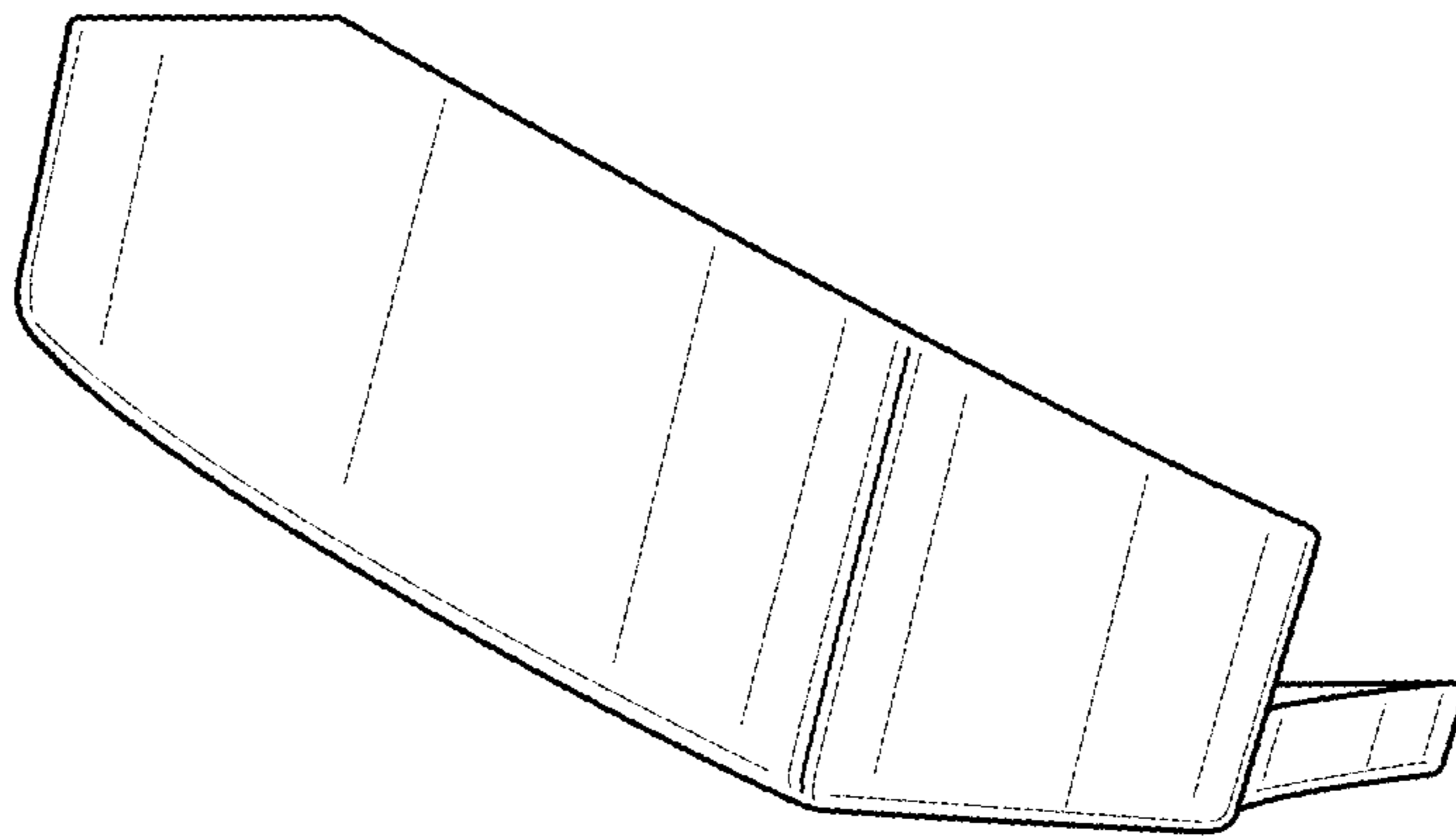

FIG. 5

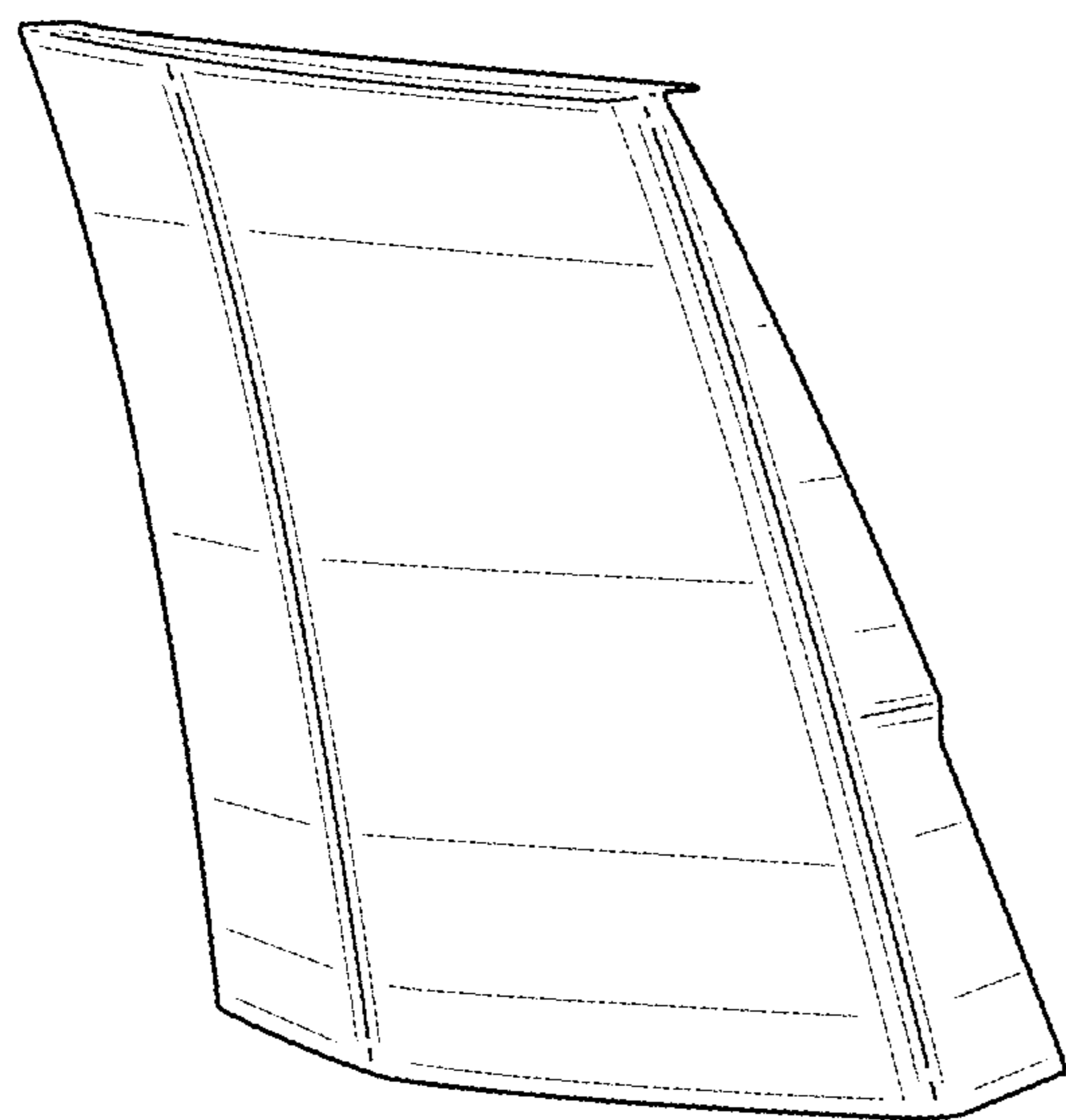

FIG. 6

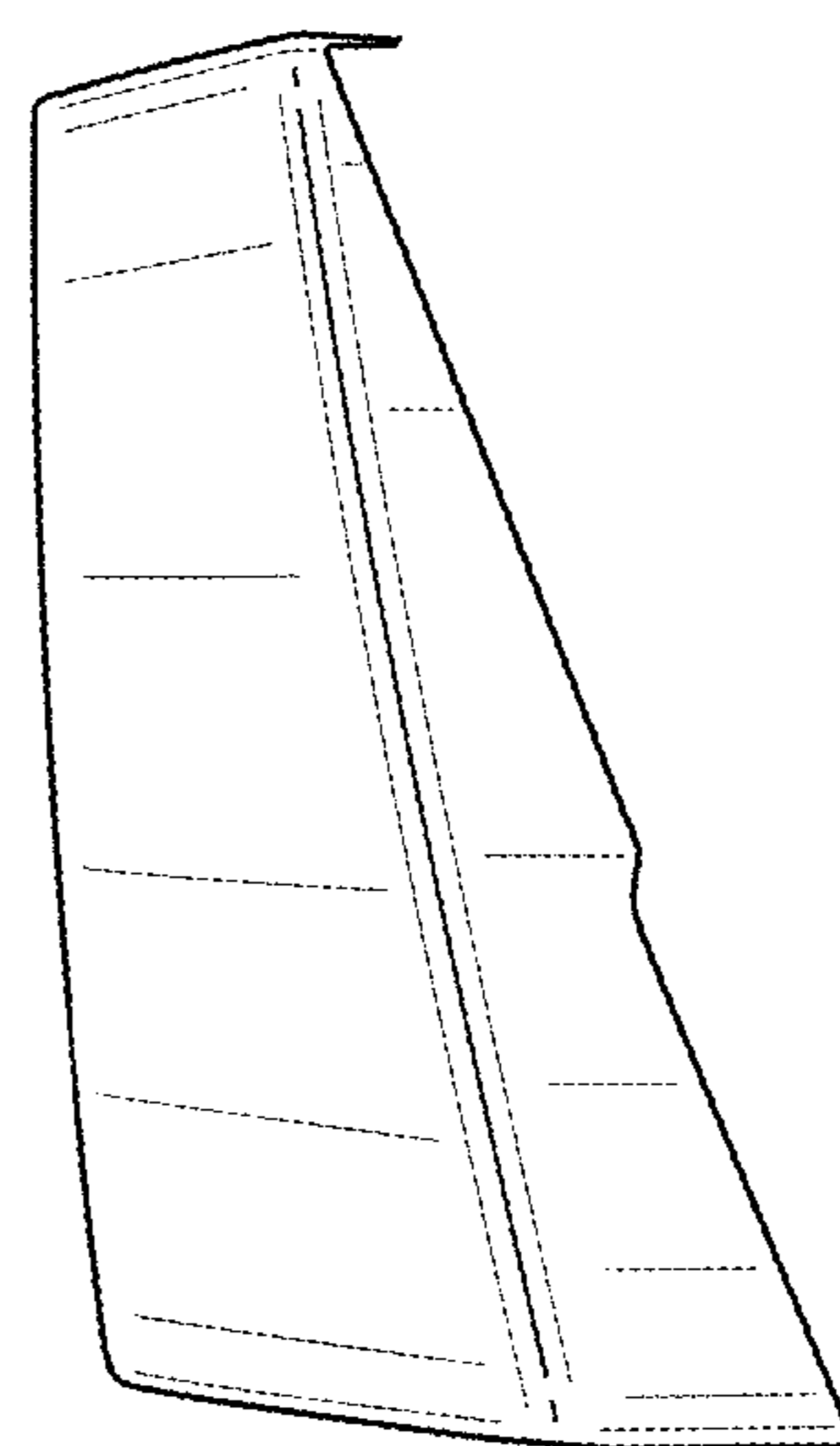

FIG. 7

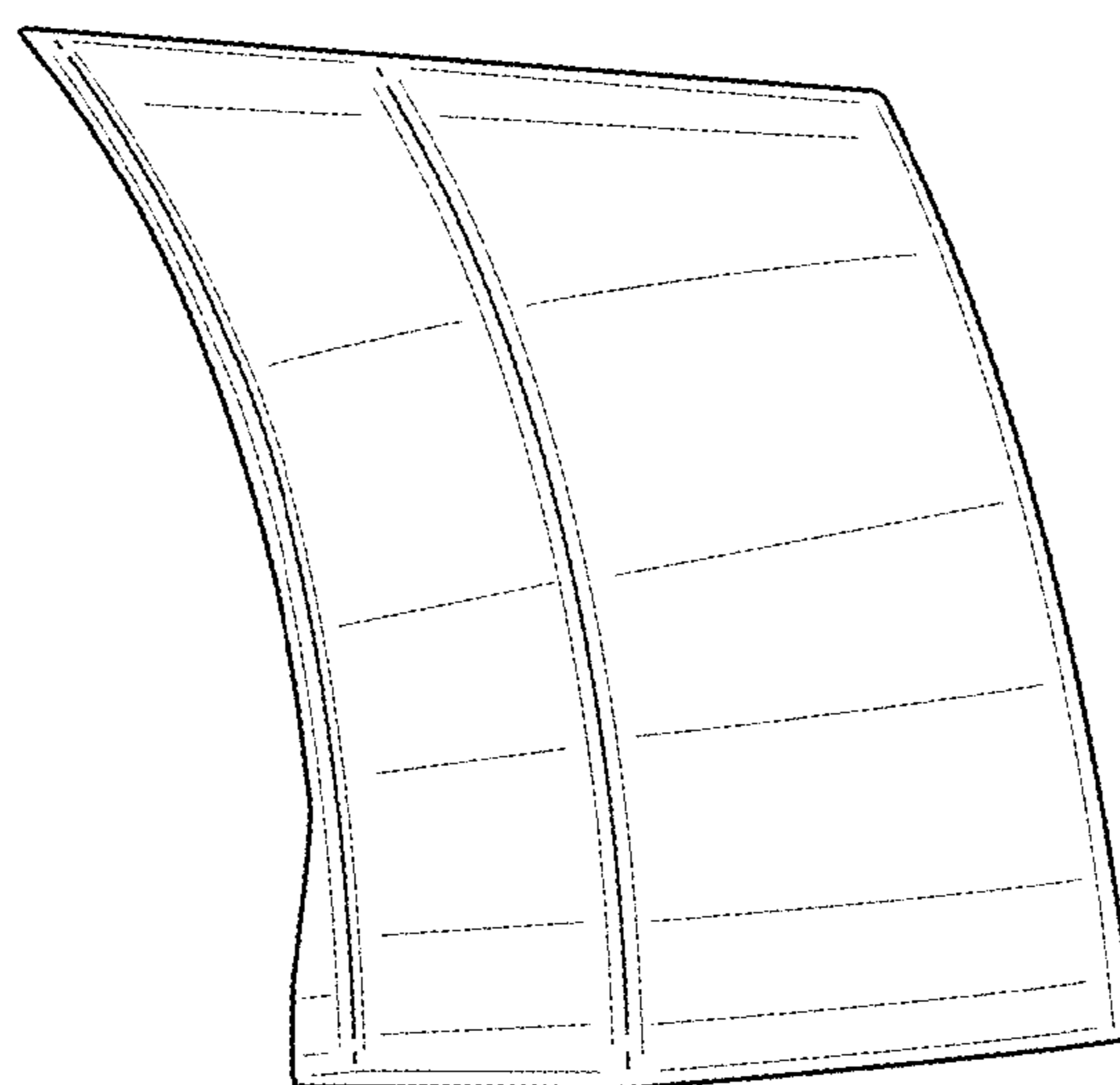

FIG. 8

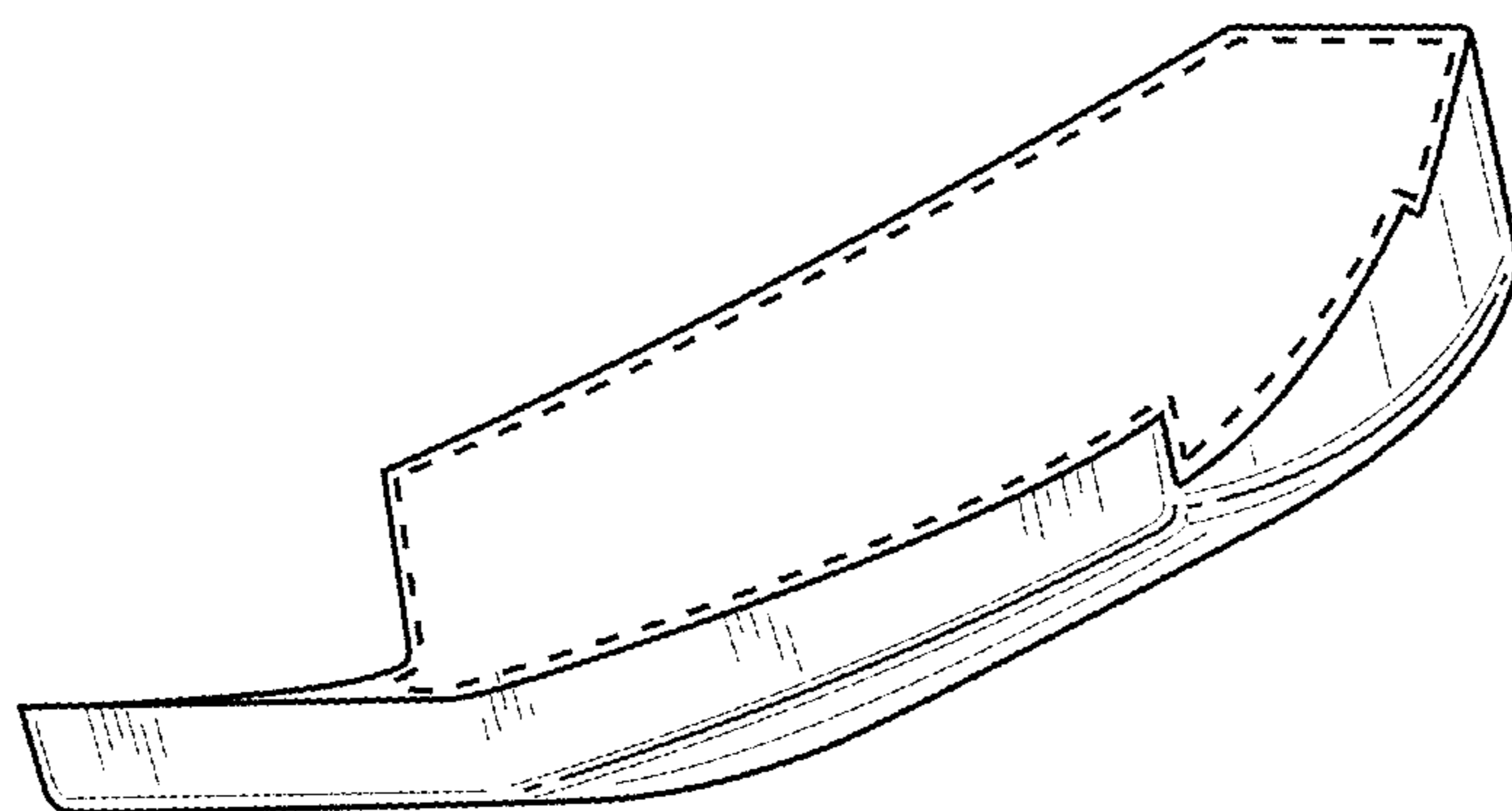

FIG. 9

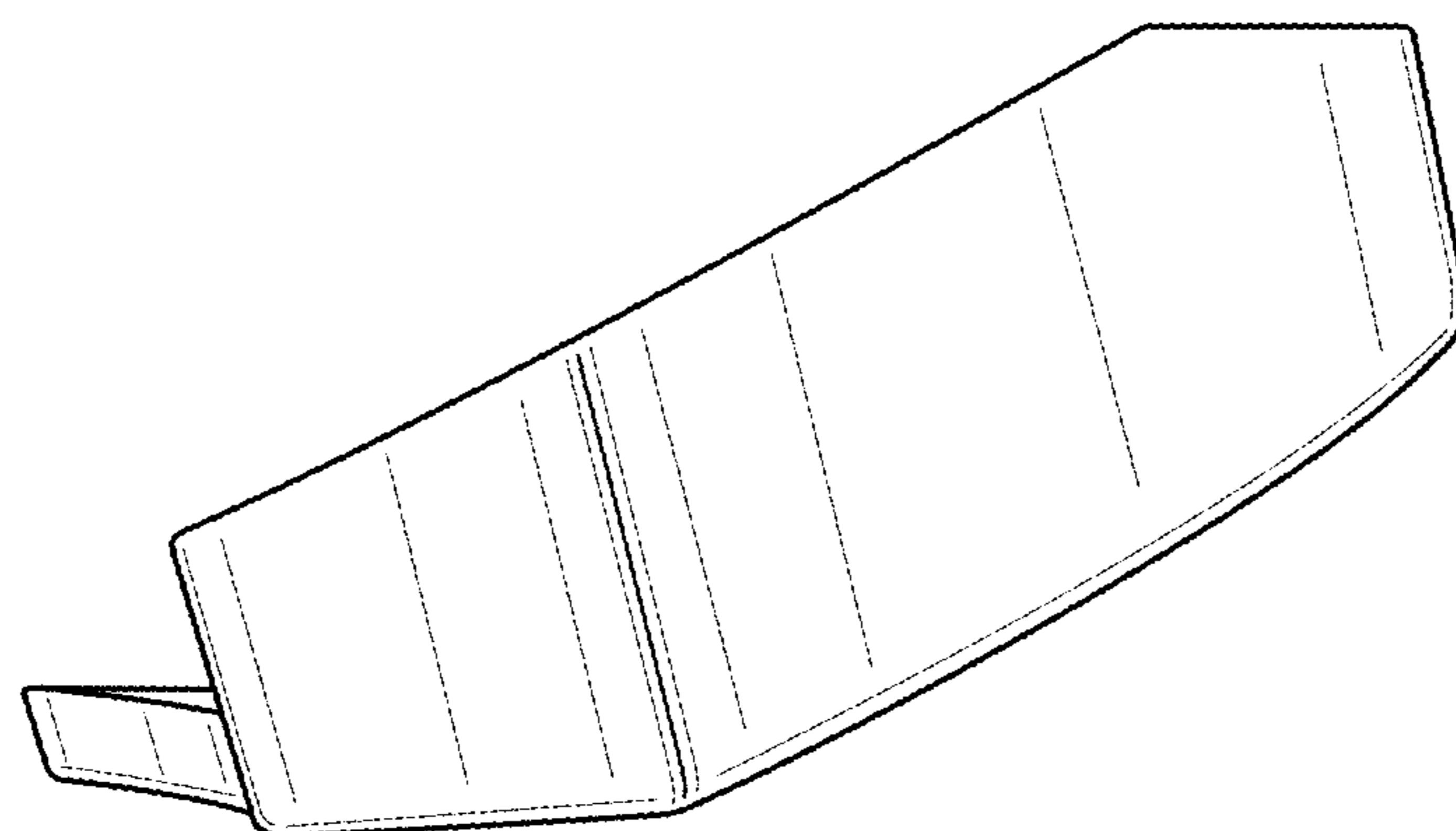

FIG. 10