



US00D771330S

(12) **United States Design Patent** (10) **Patent No.:** **US D771,330 S**  
**Ha et al.** (45) **Date of Patent:** **\*\* Nov. 8, 2016**

(54) **WASHING MACHINE**  
(71) Applicant: **LG ELECTRONICS INC.,** Seoul (KR)  
(72) Inventors: **Youngsoo Ha,** Seoul (KR); **Taewoo Yoo,** Seoul (KR); **Jonghee Han,** Seoul (KR); **Eunyoung Chee,** Seoul (KR); **Seungho Oh,** Seoul (KR); **Jeaseok Seong,** Seoul (KR)

D588,312 S \* 3/2009 Lee ..... D32/8  
D589,216 S \* 3/2009 Park ..... D32/6  
D747,836 S \* 1/2016 Cho ..... D32/6  
D750,857 S \* 3/2016 Cho ..... D32/25  
D759,909 S \* 6/2016 Kim ..... D32/6  
2003/0230017 A1\* 12/2003 Geyer ..... G09F 13/04  
40/544  
2011/0023559 A1\* 2/2011 Schone ..... D06F 37/10  
68/212

(73) Assignee: **LG ELECTRONICS INC.,** Seoul (KR)

(\*\*) Term: **15 Years**

(21) Appl. No.: **29/537,704**

(22) Filed: **Aug. 28, 2015**

(30) **Foreign Application Priority Data**

Mar. 4, 2015 (KR) ..... 30-2015-0011082

(51) **LOC (10) Cl.** ..... **15-05**

(52) **U.S. Cl.**  
USPC ..... **D32/6**

(58) **Field of Classification Search**  
USPC ..... D32/1, 5-6, 8, 25, 28, 29, 67  
CPC .. D06F 33/02; D06F 39/02; D06F 2204/065;  
D06F 25/00; D06F 35/006  
See application file for complete search history.

(56) **References Cited**

**U.S. PATENT DOCUMENTS**

D177,010 S \* 3/1956 Boldt ..... D32/6  
D236,152 S \* 7/1975 Yamamoto ..... D32/8  
D536,145 S \* 1/2007 Lee ..... D32/6  
D556,956 S \* 12/2007 Kim ..... D32/6  
D575,913 S \* 8/2008 Jeon ..... D32/6

**OTHER PUBLICATIONS**

U.S. Notice of Allowance dated Aug. 12, 2016 issued in U.S. Appl. No. 29/537,483.

U.S. Notice of Allowance dated Aug. 19, 2016 issued in U.S. Appl. No. 29/537,341.

\* cited by examiner

*Primary Examiner* — T. Chase Nelson

*Assistant Examiner* — Michelle E Wilson

(74) *Attorney, Agent, or Firm* — KED & Associates, LLP

(57) **CLAIM**

We claim the ornamental design for a washing machine, as shown and described.

**DESCRIPTION**

FIG. 1 is a perspective view of a washing machine showing our new design;

FIG. 2 is a front elevation view thereof;

FIG. 3 is a rear elevation view thereof;

FIG. 4 is a left-side elevation view thereof;

FIG. 5 is a right-side elevation view thereof;

FIG. 6 is a top plan view thereof; and,

FIG. 7 is a bottom plan view thereof.

The broken lines in the drawing figures are included to show unclaimed portions only and form no part of the claimed design.

**1 Claim, 4 Drawing Sheets**

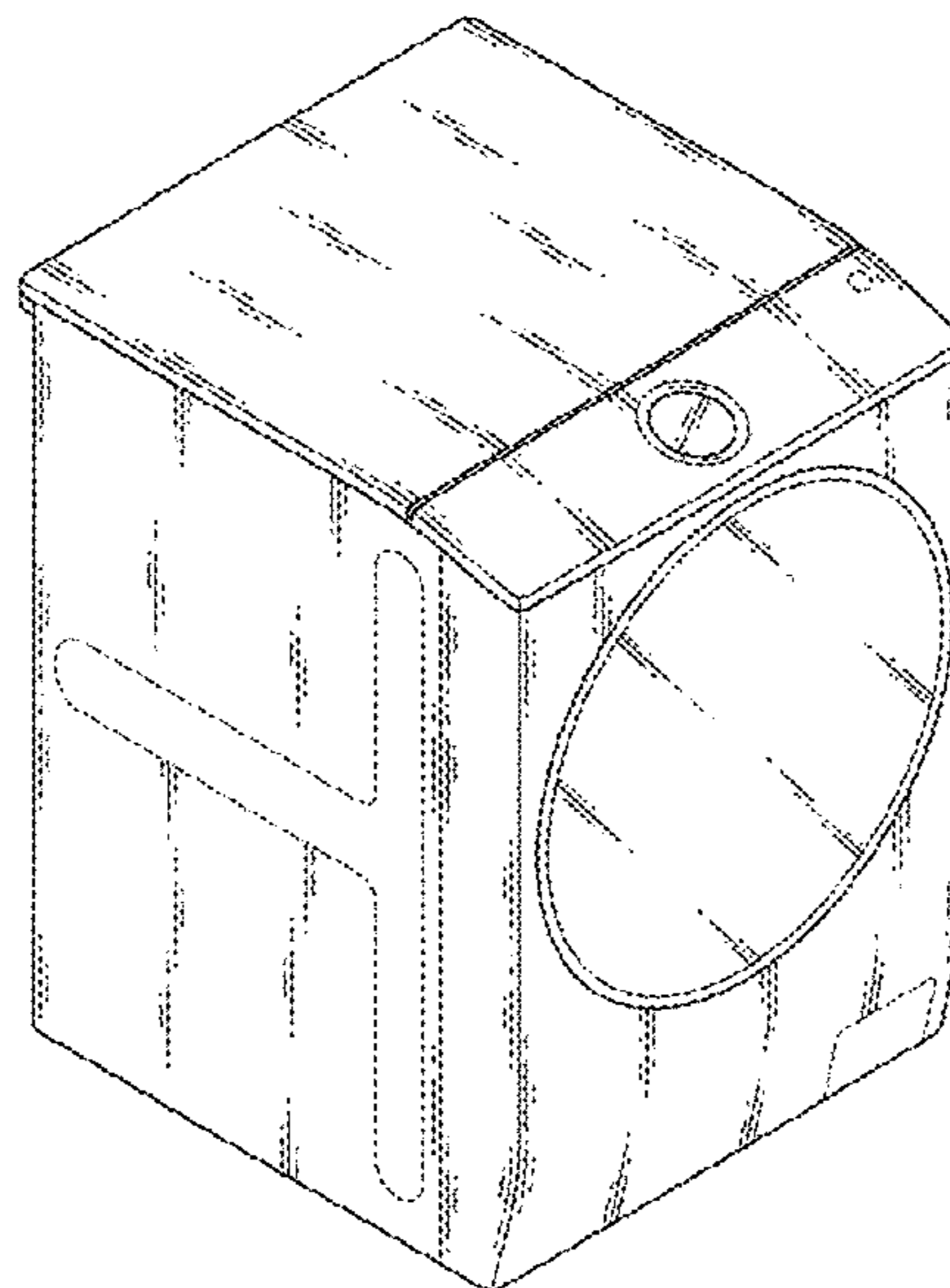

FIG. 1

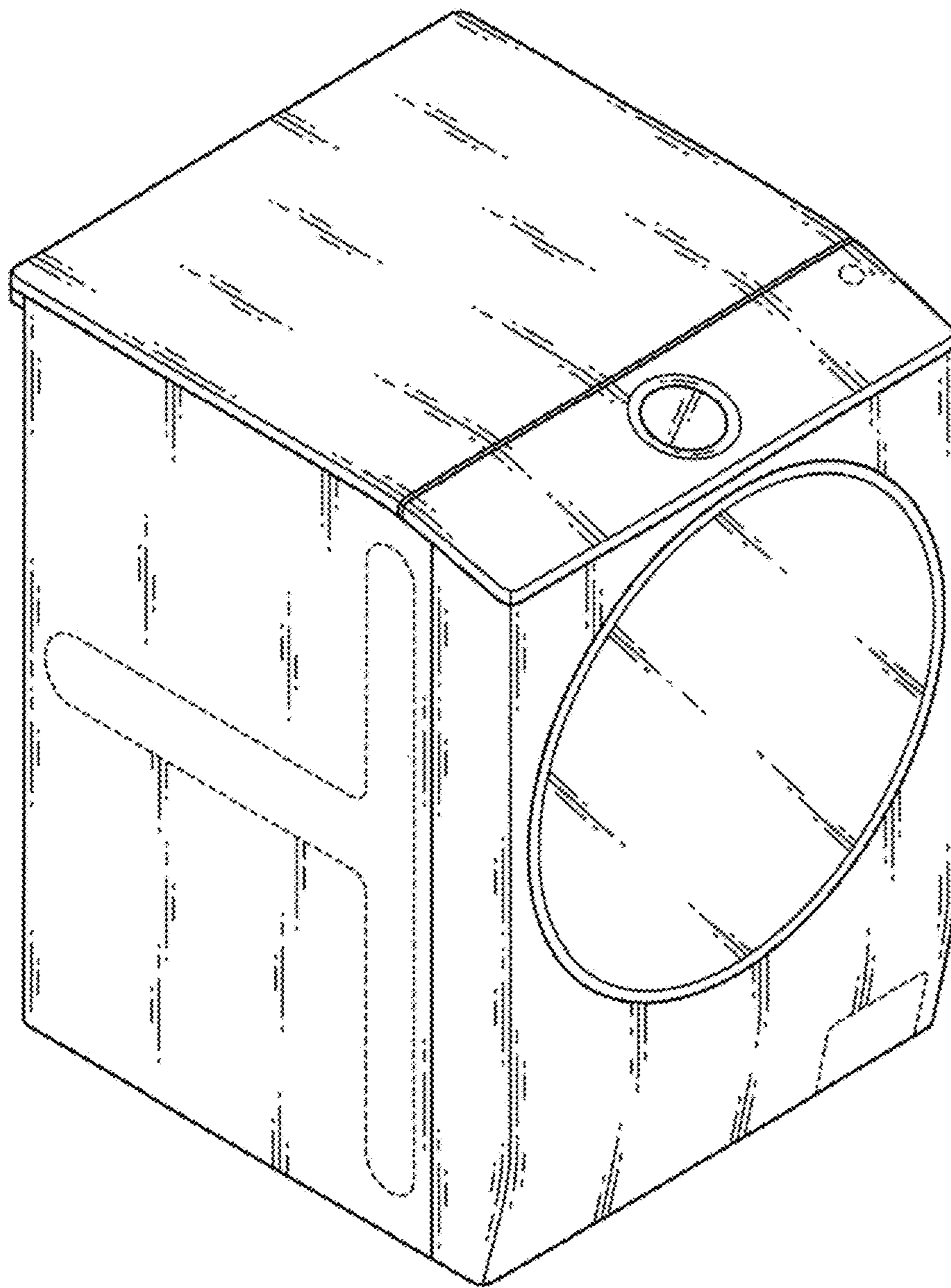

FIG. 2

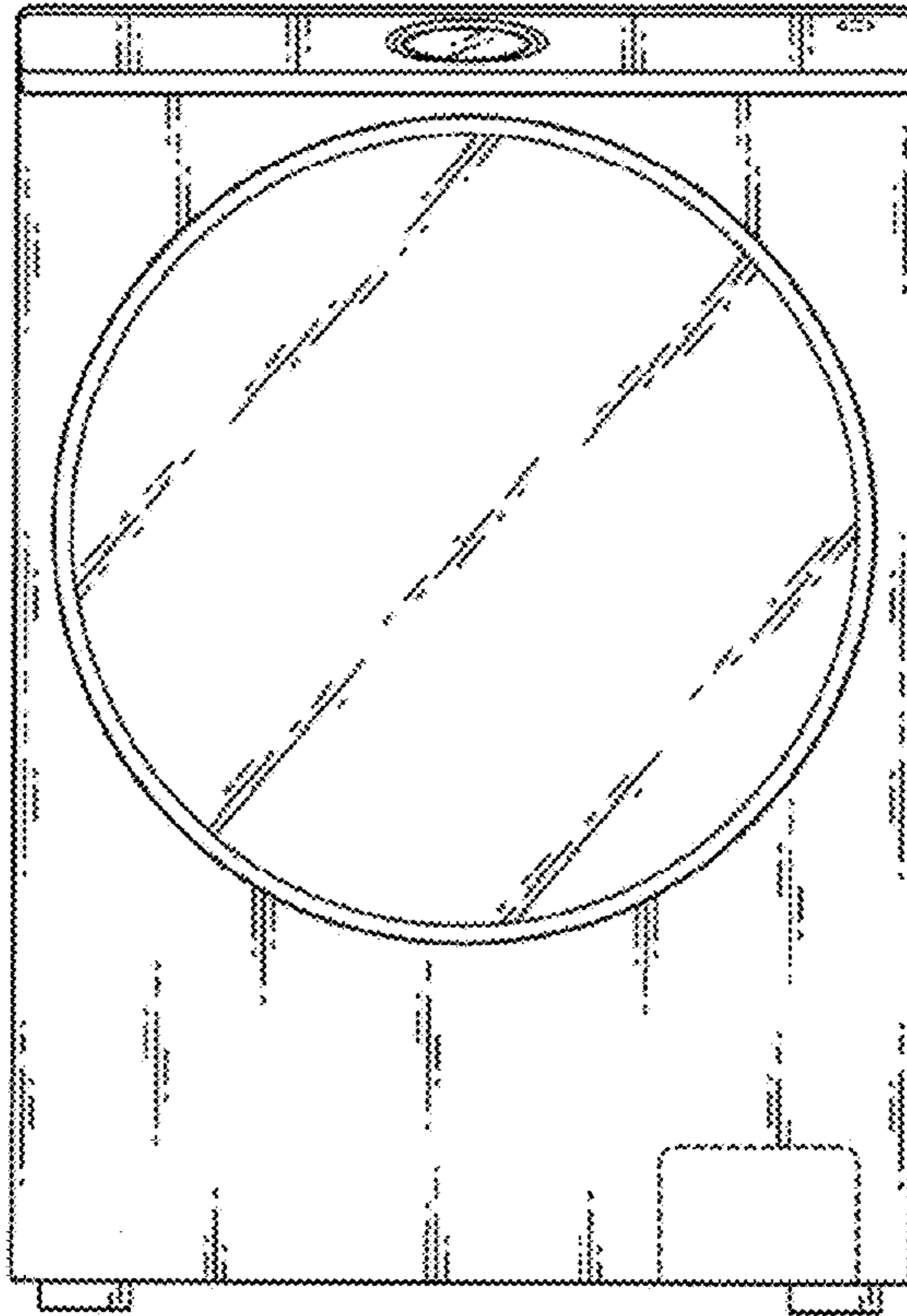

FIG. 3

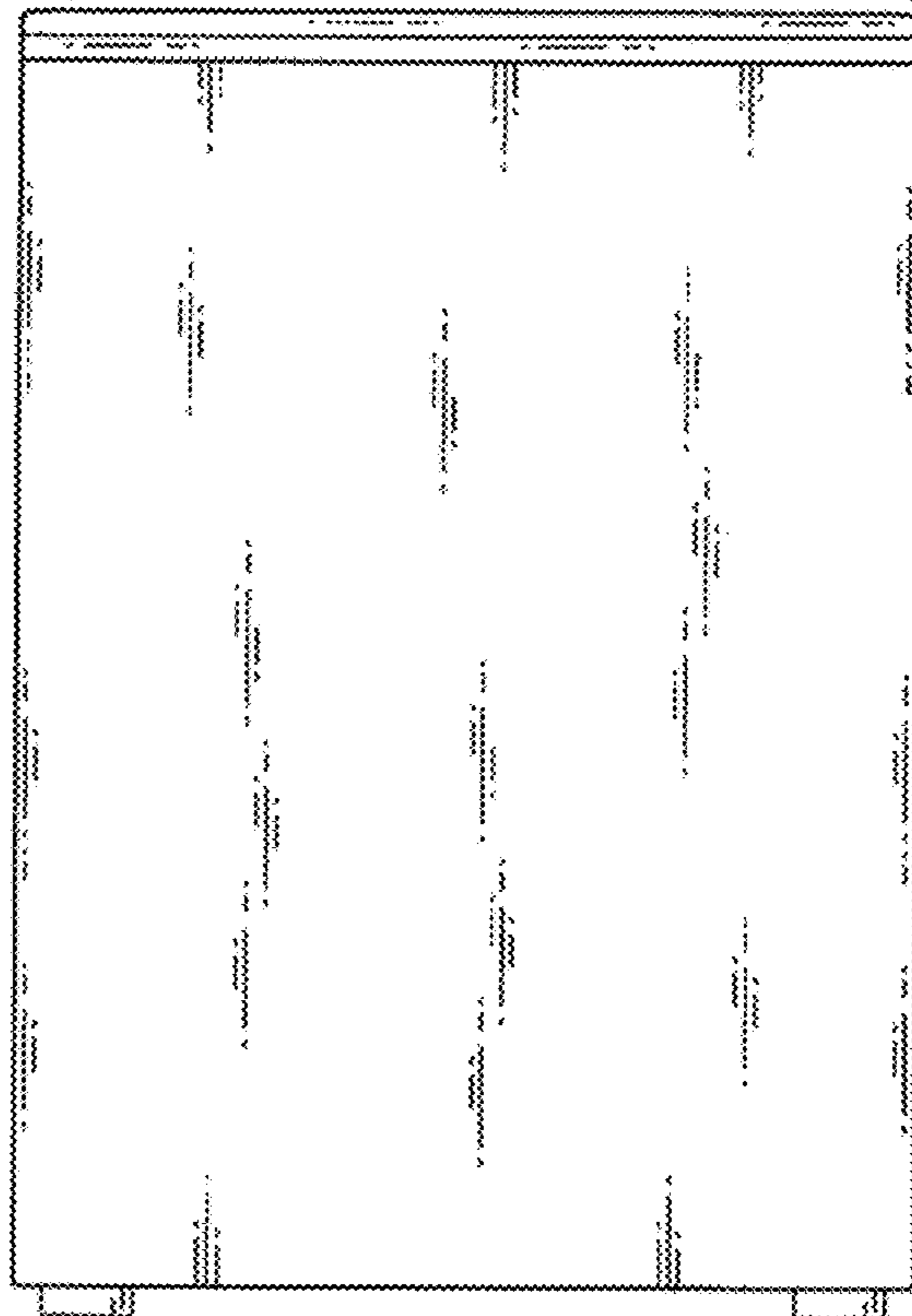

FIG. 4

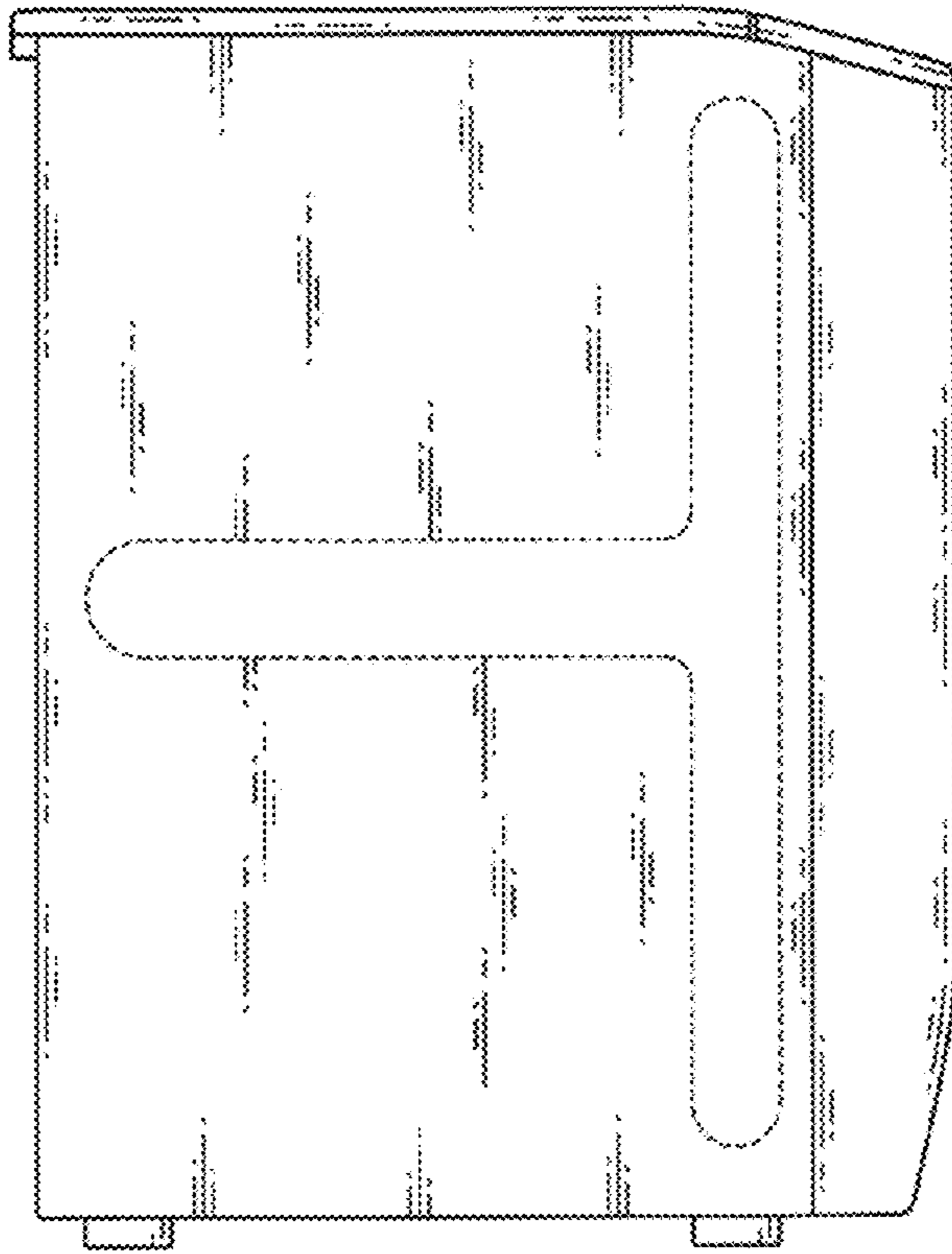

FIG. 5

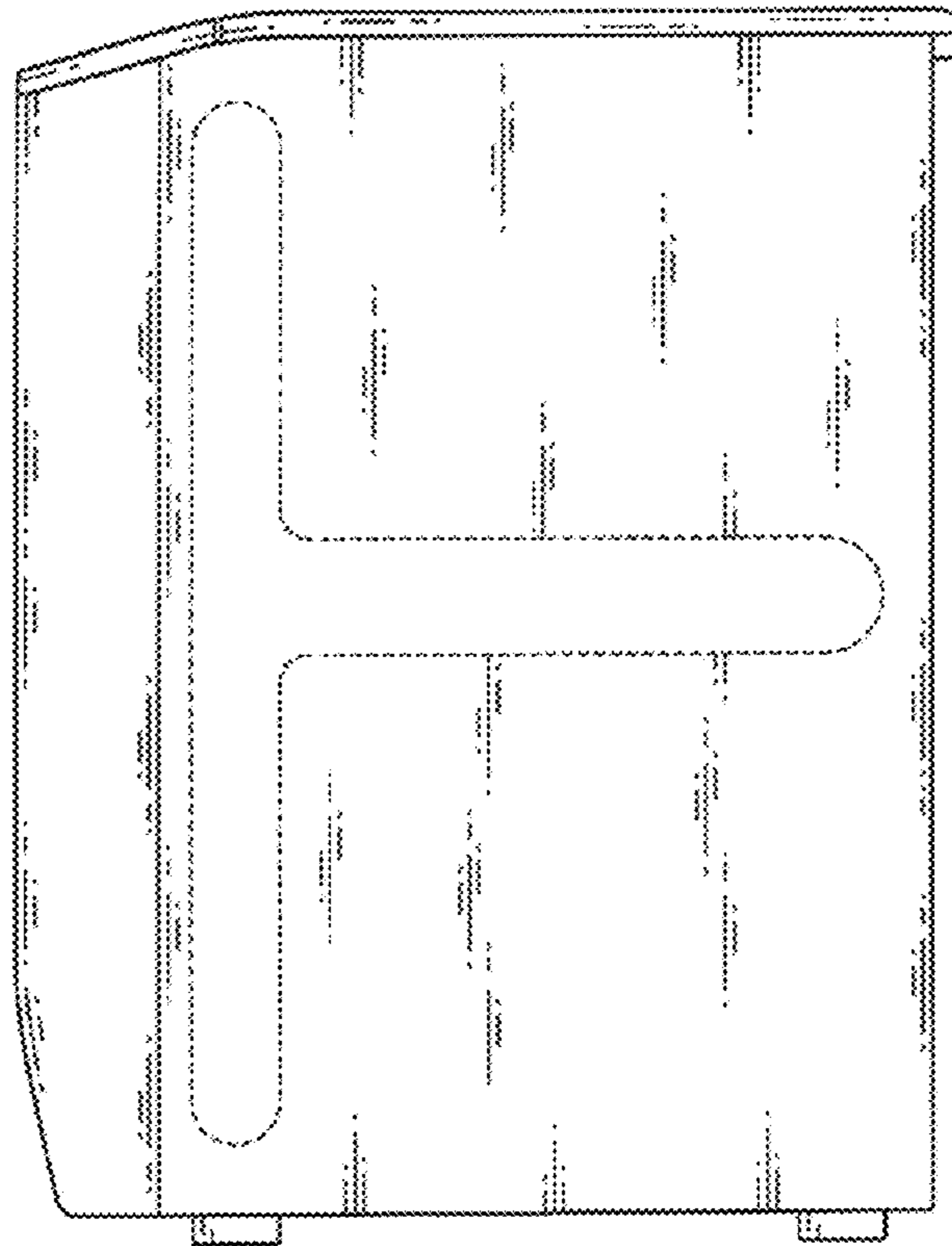

FIG. 6

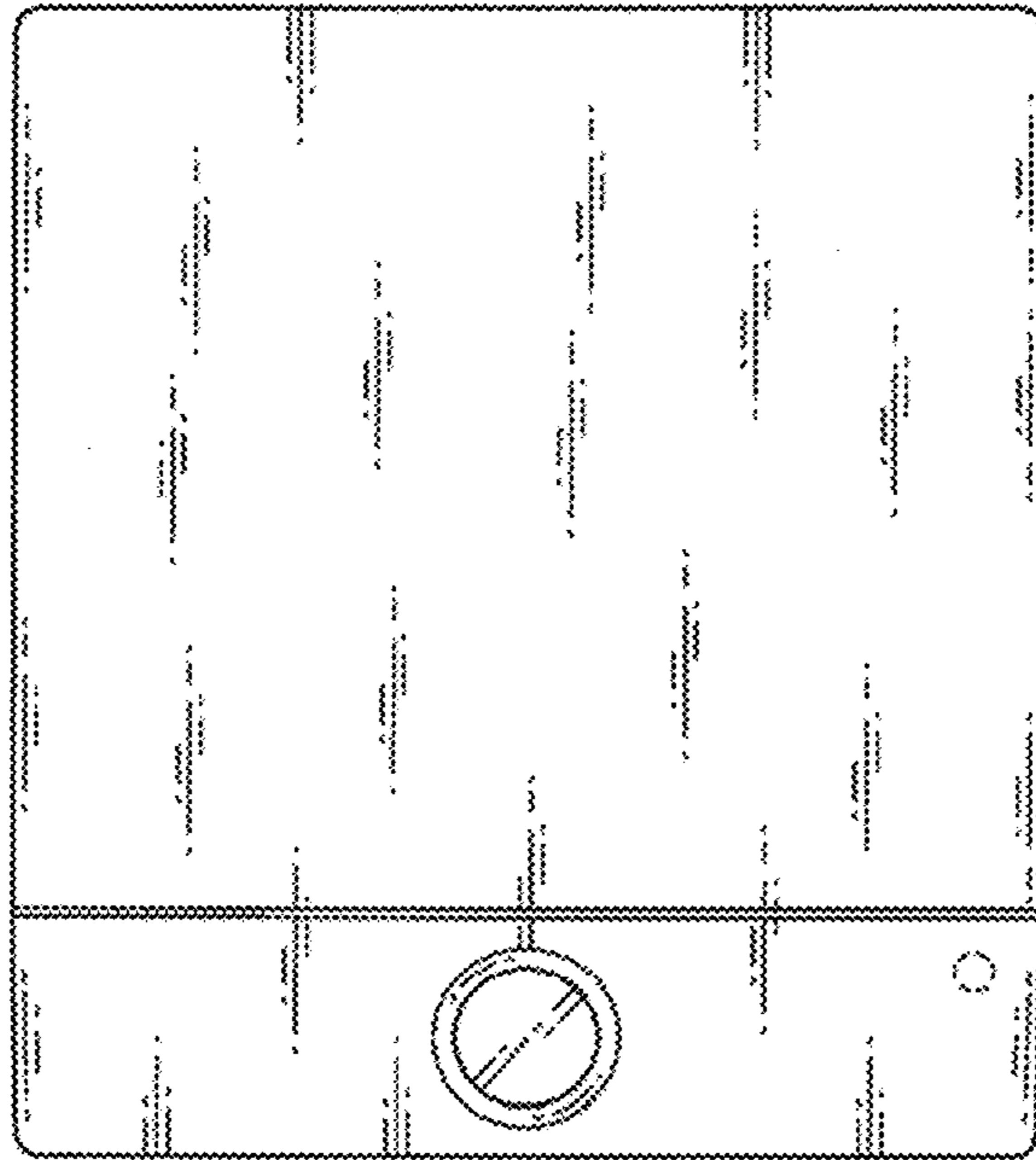

FIG. 7

