



US00D771232S

(12) **United States Design Patent** (10) **Patent No.:** **US D771,232 S**
Coon (45) **Date of Patent:** **** Nov. 8, 2016**

(54) **ADJUSTABLE CHANNEL FOR AN AIR
CONDITIONING LINE SET**

(71) Applicant: **Stephen A. Coon**, Windermere, FL
(US)

(72) Inventor: **Stephen A. Coon**, Windermere, FL
(US)

(**) Term: **14 Years**

(21) Appl. No.: **29/507,610**

(22) Filed: **Oct. 29, 2014**

(51) **LOC (10) Cl.** **23-04**

(52) **U.S. Cl.**
USPC **D23/393**

(58) **Field of Classification Search**

USPC D13/139.2; D23/323, 328, 333, 335,
D23/336, 337, 341, 352, 357, 370, 385, 386,
D23/388, 392, 397, 399, 400, 406, 411, 412,
D23/413, 499

CPC B65D 7/00; B65D 67/02; F16M 1/00;
F24F 1/027; F24F 13/32; F25D 23/10;
E04F 17/08; F16L 3/26; F16L 9/22; F16K
1/221; F16K 1/443; F16K 31/122; F23L
11/005; F24H 1/205; F24H 9/0026; F24H
9/0031; F24H 9/2035; F23N 2025/22;
F23N 2035/18; F23N 2035/20

See application file for complete search history.

(56) **References Cited**

U.S. PATENT DOCUMENTS

594,998 A * 12/1897 Lyle F16L 9/22
138/115
799,320 A * 9/1905 Franks F16L 9/22
138/154

(Continued)

OTHER PUBLICATIONS

Mitsubishi Line-Hide Split Line Tube Line Set Cover, image post date Apr. 14, 2014, site visited Jun. 11, 2016, (online), <<http://www.ecomfort.com/Mitsubishi-CD-75/p30651.html>>.*

(Continued)

Primary Examiner — Kevin Rudzinski

Assistant Examiner — Sean D Lough

(74) *Attorney, Agent, or Firm* — Terry M. Sanks, Esq.;
Beusse Wolter Sanks & Maire, PLLC

(57) **CLAIM**

The ornamental design for the adjustable channel for an air conditioning line set, as shown and described.

DESCRIPTION

FIG. 1 is a perspective view of the top section and bottom section of the adjustable channel for an air conditioning line set;

FIG. 2 is a front view and a back view of the top section and bottom section of the claimed design when connected;

FIG. 3 is a front view and a back view of the top section of the claimed design, with the bottom section omitted for ease of disclosure;

FIG. 4 is a front view and a back view of the bottom section of the claimed design, with the top section omitted for ease of disclosure;

FIG. 5 is a top view of the top section of the claimed design with the bottom section omitted for ease of disclosure;

FIG. 6 is a bottom view of the top section of the claimed design, with the bottom section omitted for ease of disclosure;

FIG. 7 is a top view of the bottom section of the claimed design, with the top section omitted for ease of disclosure;

FIG. 8 is a bottom view of the bottom section of the claimed design with the top section omitted for ease of disclosure;

FIG. 9 is a side view of the top section and bottom section of the claimed design when connected;

FIG. 10 is a side view of the top section of the claimed design, with the bottom section omitted for ease of disclosure; and,

FIG. 11 is a side view of the bottom section of the claimed design, with the top section omitted for ease of disclosure.

1 Claim, 5 Drawing Sheets

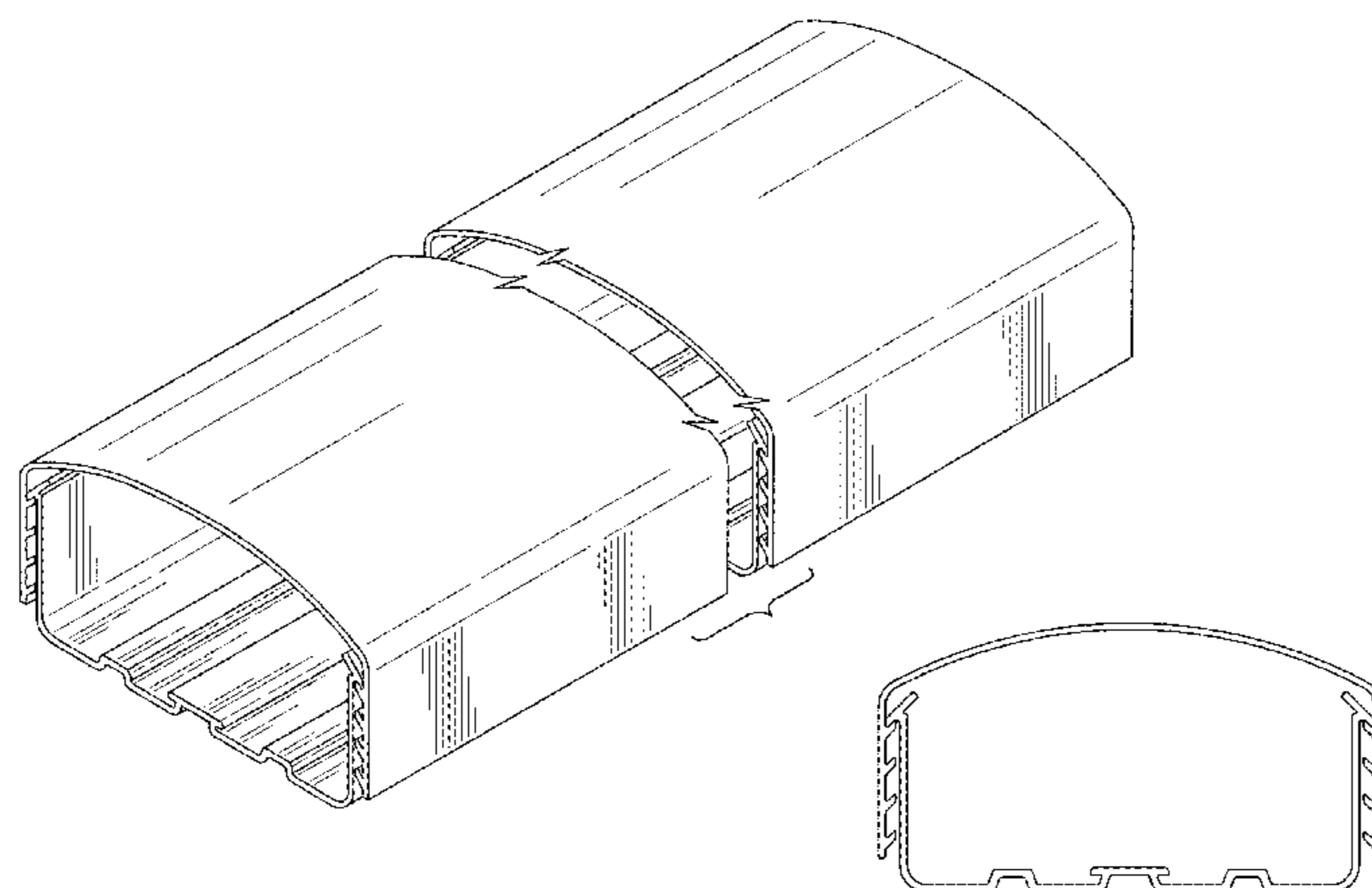

(56)

References Cited

U.S. PATENT DOCUMENTS

820,342 A * 5/1906 Besser F16L 9/22
138/157

937,876 A * 10/1909 Sioklesteel et al. F16L 9/22
138/162

1,165,425 A * 12/1915 Lundergan F16L 9/22
138/157

1,189,208 A * 6/1916 Hodkinson F16L 9/22
138/157

1,642,417 A * 9/1927 Kovanda F16L 9/22
110/184

2,540,141 A * 2/1951 Shafer E21D 11/15
138/158

2,637,346 A * 5/1953 Jewell B28B 21/70
138/141

2,702,564 A * 2/1955 Busch F16L 9/02
138/163

3,521,843 A * 7/1970 Ogle F16L 3/26
174/68.3

3,656,515 A * 4/1972 Wogerbauer E04C 3/06
138/171

3,927,698 A * 12/1975 Johannsen H02G 3/0437
138/157

4,032,821 A * 6/1977 Keiser E04F 17/08
137/360

4,164,243 A * 8/1979 Cookson H02G 5/063
138/162

4,627,469 A * 12/1986 Buard H02G 3/0425
138/117

4,640,314 A * 2/1987 Mock H02G 3/0418
138/157

4,655,520 A * 4/1987 Cummings F21V 21/002
439/111

4,693,635 A * 9/1987 Matiere E04H 7/28
138/155

4,835,936 A * 6/1989 Matiere F16L 9/22
52/223.3

D318,343 S * 7/1991 Miller D13/155

D318,742 S * 7/1991 Miller D13/155

5,251,412 A * 10/1993 de Almeida Borges .. E04B 7/00
52/109

5,336,849 A * 8/1994 Whitney E04F 17/08
174/101

5,412,552 A * 5/1995 Fernandes F21S 2/00
174/101

5,442,885 A * 8/1995 Laven E04C 3/07
29/453

5,526,617 A * 6/1996 Grice E03B 7/09
52/106

5,607,126 A * 3/1997 Cordola F16L 3/26
248/316.7

5,653,412 A * 8/1997 Martorano F21V 21/025
248/222.11

5,791,631 A * 8/1998 Martin F23N 1/007
251/210

6,000,187 A * 12/1999 Shimizu F16L 3/26
248/49

6,012,683 A * 1/2000 Howell F16L 3/26
174/101

6,059,582 A * 5/2000 Tsai H01R 25/147
362/287

6,220,721 B1 * 4/2001 Chan F21S 2/00
362/219

6,380,484 B1 * 4/2002 Theis F16L 3/26
174/101

6,390,139 B1 * 5/2002 Kang F16L 9/22
138/120

D532,375 S * 11/2006 Kim D13/139.2

D539,228 S * 3/2007 Toikka D13/155

D539,232 S * 3/2007 Lozano D13/155

D539,753 S * 4/2007 Makwinski D13/155

D539,754 S * 4/2007 Makwinski D13/139.2

D539,755 S * 4/2007 Makwinski D13/155

D541,143 S * 4/2007 Ruddick D13/155

D561,915 S * 2/2008 Sigmund D25/55

7,465,063 B2 * 12/2008 Stillman F21L 14/026
362/219

D594,563 S * 6/2009 Polston D25/136

D602,346 S * 10/2009 Allsopp D8/369

D629,883 S * 12/2010 Kimura D23/388

8,764,220 B2 * 7/2014 Chan F21V 15/013
362/217.02

D720,702 S * 1/2015 Baldwin D13/155

D738,026 S * 9/2015 Dungan D26/76

9,285,084 B2 * 3/2016 Amrine, Jr. F21K 9/17

9,291,316 B2 * 3/2016 Dixon F21L 4/00

9,303,847 B2 * 4/2016 Dellian F21V 17/08

D757,240 S * 5/2016 Forlong D23/393

2002/0185189 A1 * 12/2002 Tadokoro H02G 3/0468
138/156

2003/0080259 A1 * 5/2003 Robicheau F16L 3/26
248/58

2003/0091392 A1 * 5/2003 Bevilacqua F16L 9/003
405/48

2003/0137835 A1 * 7/2003 Mier-Langner F21S 8/06
362/220

2004/0104315 A1 * 6/2004 Betz H02G 3/26
248/74.2

2004/0115004 A1 * 6/2004 Serrano F16L 3/02
405/157

2005/0081281 A1 * 4/2005 Hannon A41D 15/005
2/275

2005/0152132 A1 * 7/2005 Bernhart F21S 8/06
362/147

2006/0012977 A1 * 1/2006 Joseph F21V 21/35
362/147

2006/0101745 A1 * 5/2006 Kleege E04B 2/827
52/243.1

2006/0113432 A1 * 6/2006 Driskell A61M 39/08
248/68.1

2006/0180636 A1 * 8/2006 Muehleck F16C 29/06
228/3.1

2007/0153509 A1 * 7/2007 Lehman H01R 25/145
362/219

2007/0241629 A1 * 10/2007 Ionel H02K 1/141
310/214

2009/0058078 A1 * 3/2009 Knudson F16L 9/22
285/136.1

2009/0110494 A1 * 4/2009 Hinsley B65G 51/18
406/88

2009/0267307 A1 * 10/2009 Smith F16L 21/022
277/584

2009/0296381 A1 * 12/2009 Dubord F21S 2/005
362/218

2010/0130055 A1 * 5/2010 Liang E04B 9/068
439/532

2010/0307628 A1 * 12/2010 Rowan F16L 9/003
138/149

2011/0095140 A1 * 4/2011 Armit E03B 7/095
248/68.1

2011/0114802 A1 * 5/2011 Hjerpe F16L 3/222
248/68.1

2011/0317435 A1 * 12/2011 Wang F21V 21/025
362/370

2012/0241657 A1 * 9/2012 Sisk F16K 27/0218
251/293

2012/0286110 A1 * 11/2012 Hill F16L 3/13
248/74.2

2013/0044469 A1 * 2/2013 Crimi F21S 8/066
362/217.11

2014/0016503 A1 * 1/2014 Altekarr H01R 25/142
370/254

2014/0260071 A1 * 9/2014 Coon E04F 17/08
52/741.1

2014/0328055 A1 * 11/2014 Maxik F21S 8/03
362/218

2015/0316238 A1 * 11/2015 Guilmette H01R 25/14
362/218

OTHER PUBLICATIONS

Single Channel Raceway BPS 3800 Series, image post date Sep. 6, 2013, site visited Jun. 11, 2016, (online), <<http://web.archive.org/web/20130906202143/http://brookspower.com/prewiredraceway-3800series.html>>.*

(56)

References Cited

OTHER PUBLICATIONS

Extrusion with Spline Track, image post date Jun. 11, 2013, site visited Jun. 11, 2016, (online), <<http://www.homedepot.com/p/EZ-Screen-Room-8-ft-x-2-in-x-2-in-Aluminum-White-Extrusion-with-Spline-Track-EZSR8PW/202453633>>.*

SiDaWang Led Lighting, image post date 2015, site visited Jun. 11, 2016, (online), <[http://fr.aliexpress.com/item/6pc-6m-pack-1m-per-](http://fr.aliexpress.com/item/6pc-6m-pack-1m-per)

piece-Wide-Aluminum-U-channel-profile-for-Double-row-Kitchen-led/32317401200.html?spm=2114.44010308.4.11.EzhibU>.*

Bar light led strip light channel, image post date 2004, site visited Jun. 11, 2016, (online), <<http://m.dhgate.com/product/10pcs-lot-led-aluminium-profile-for-led-bar/186673841.html#cppd-8-9|null:01:494512225>>.*

* cited by examiner

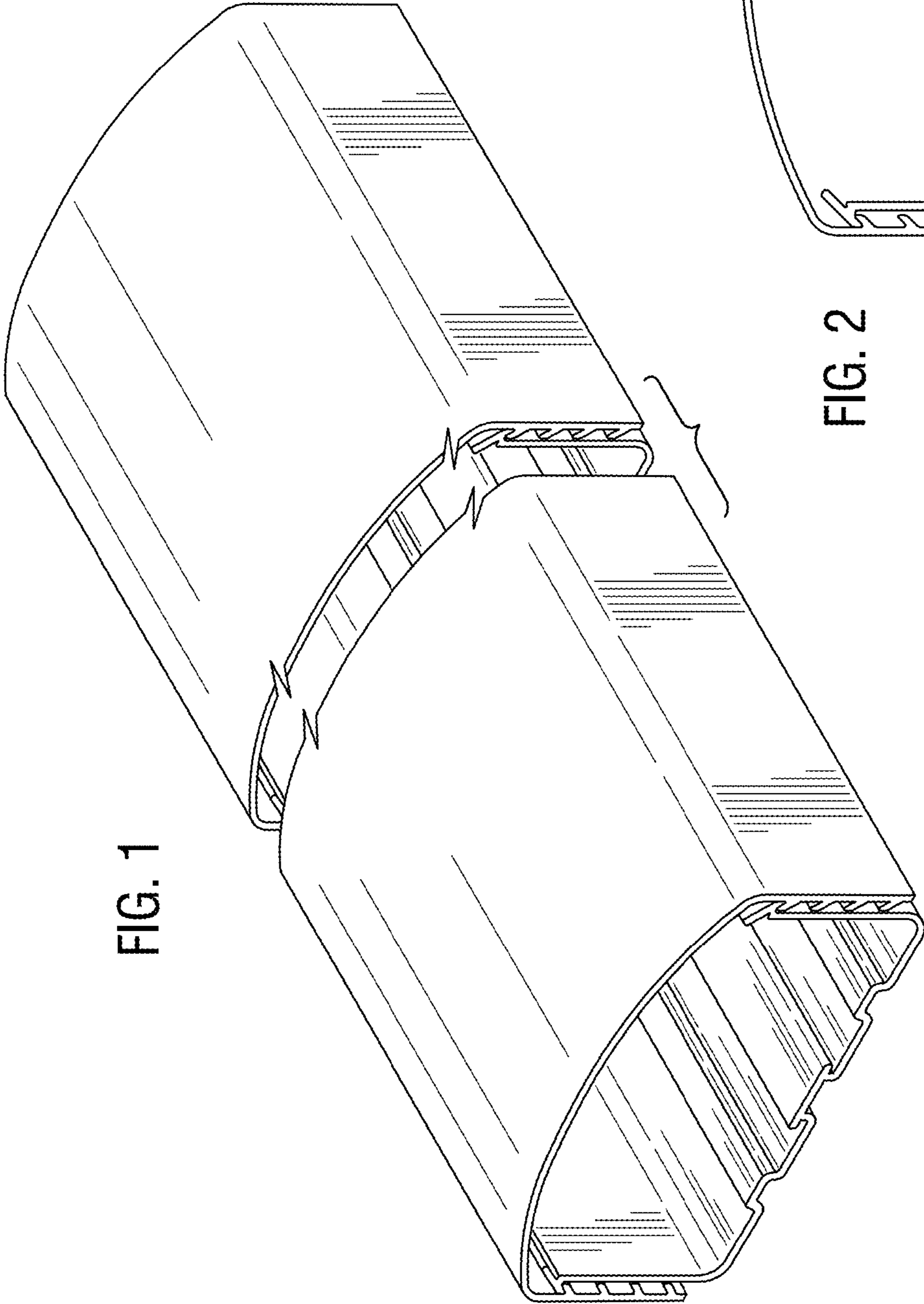

FIG. 1

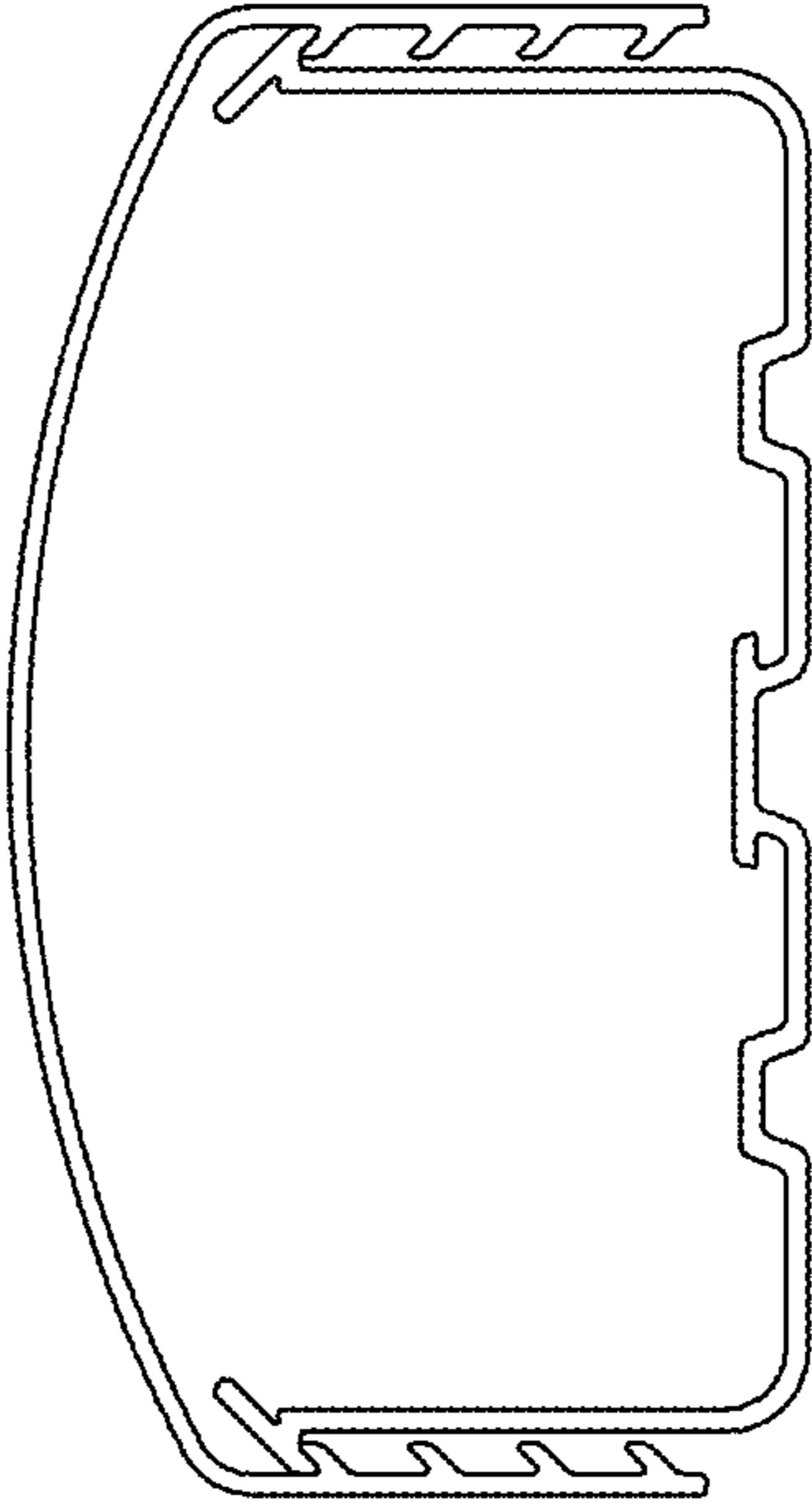

FIG. 2

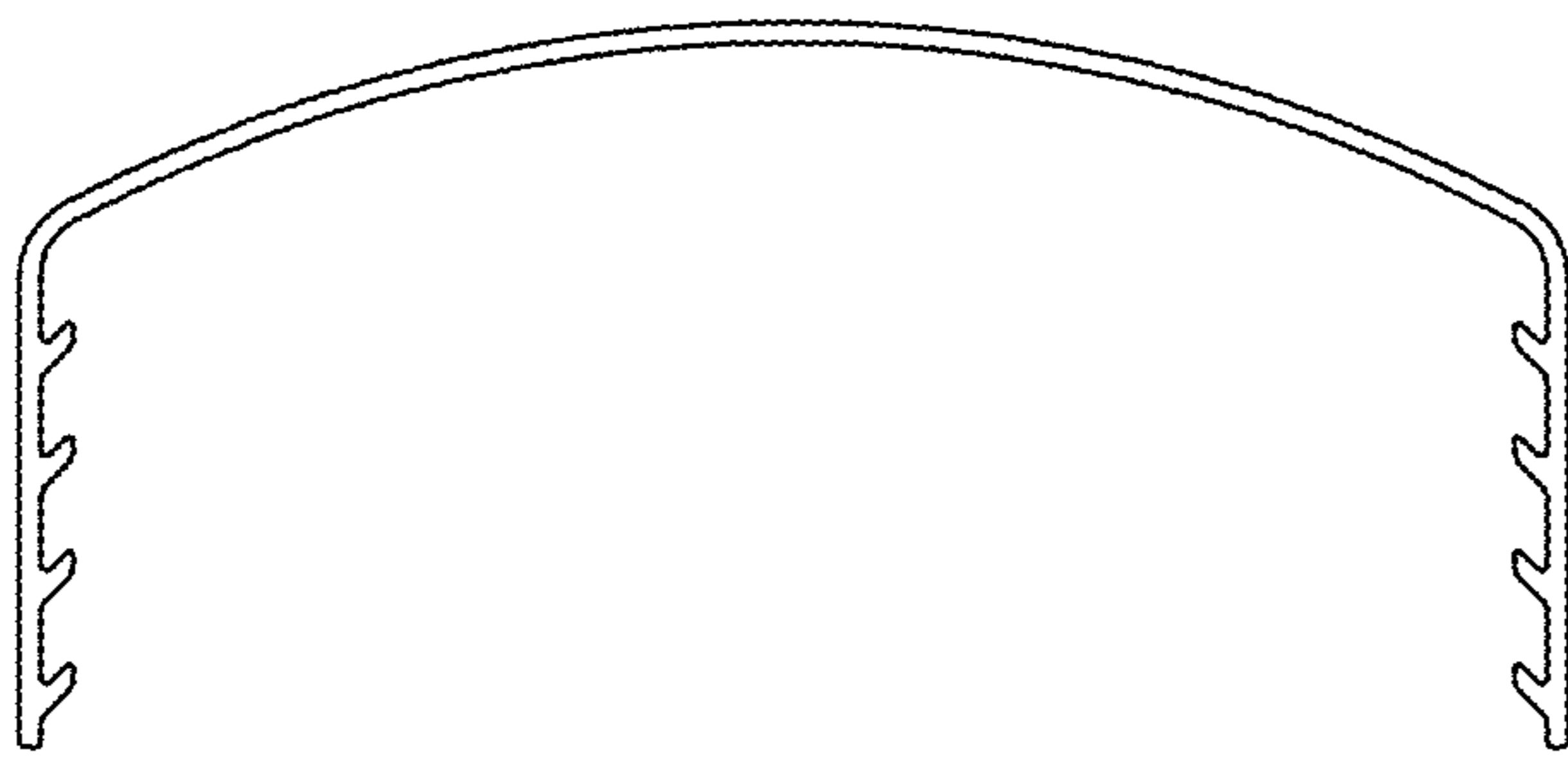

FIG. 3

FIG. 4

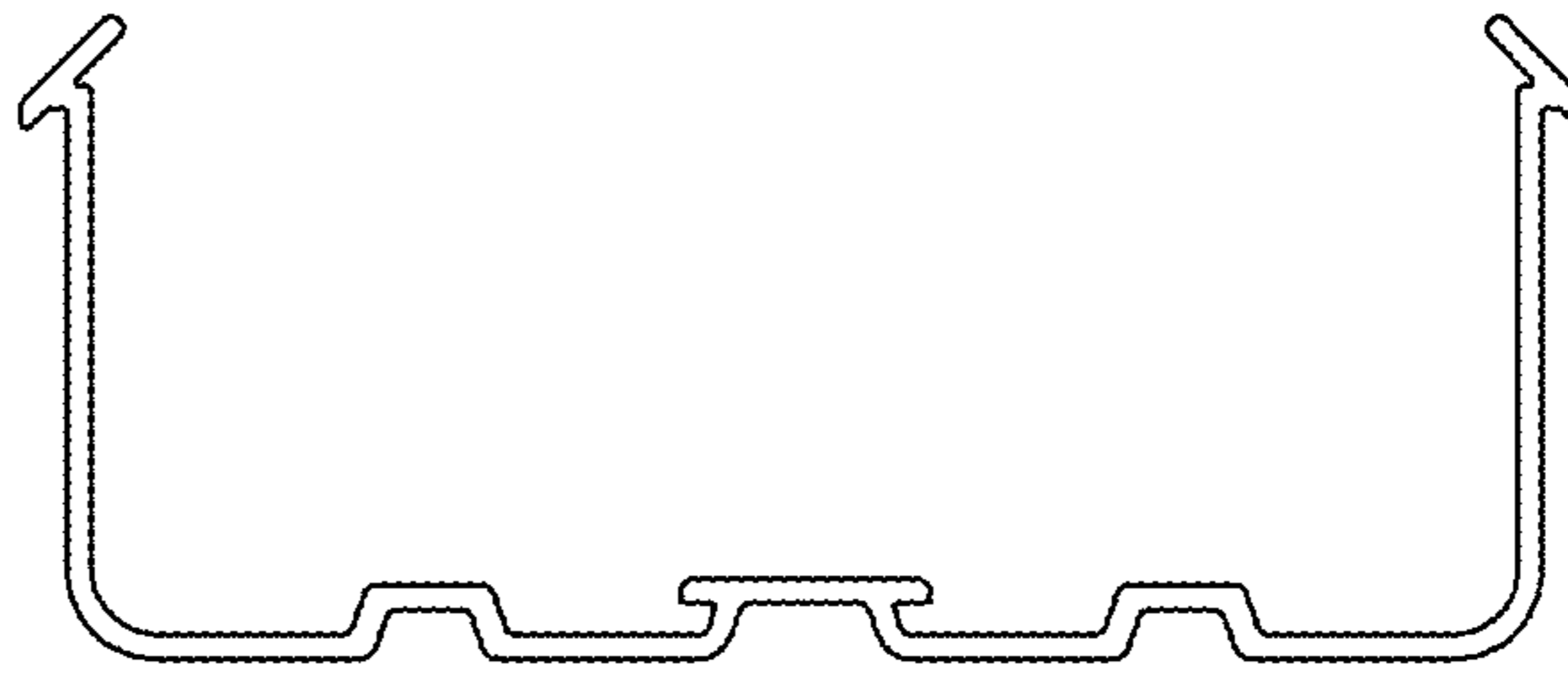

FIG. 5

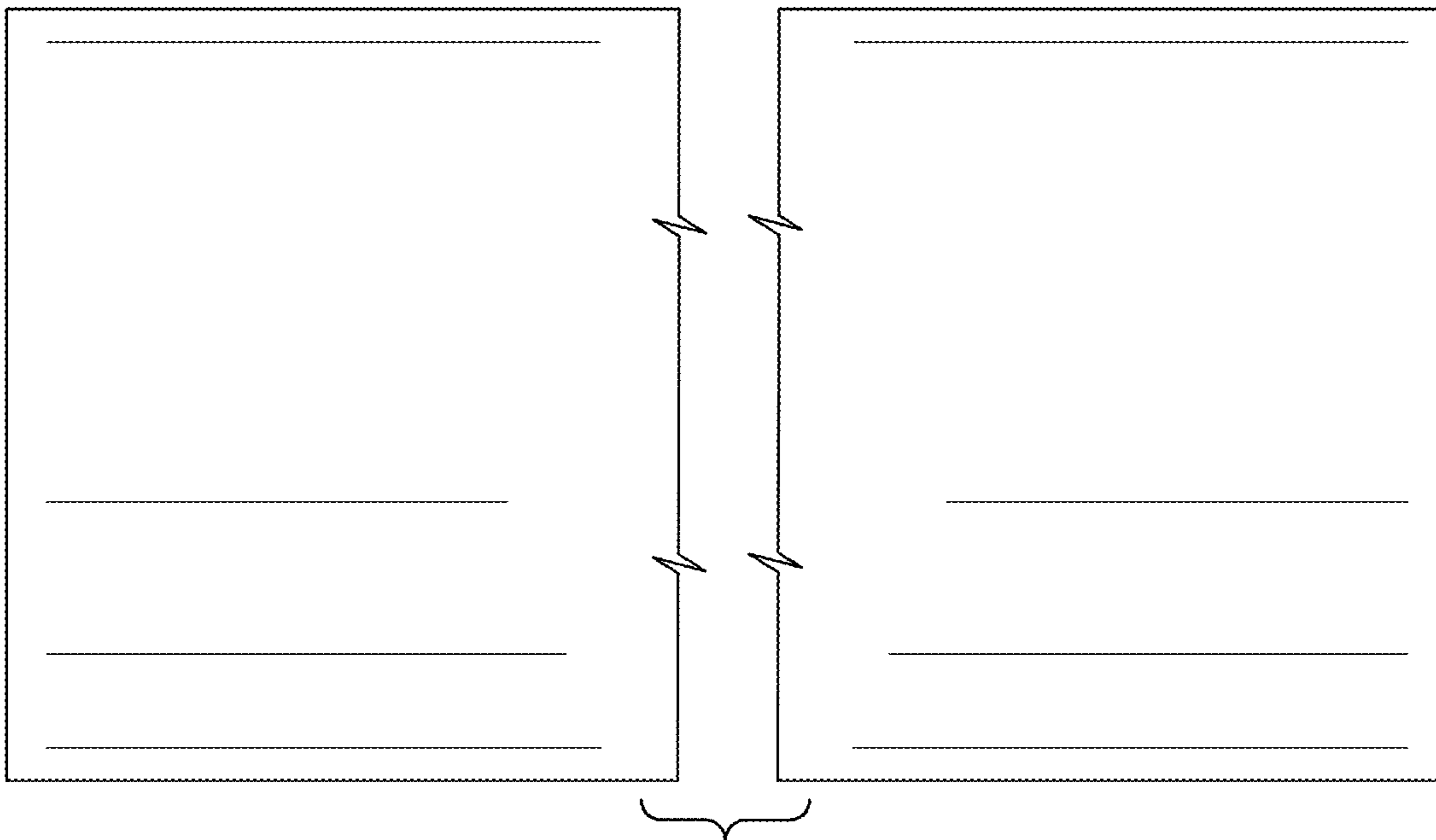

FIG. 6

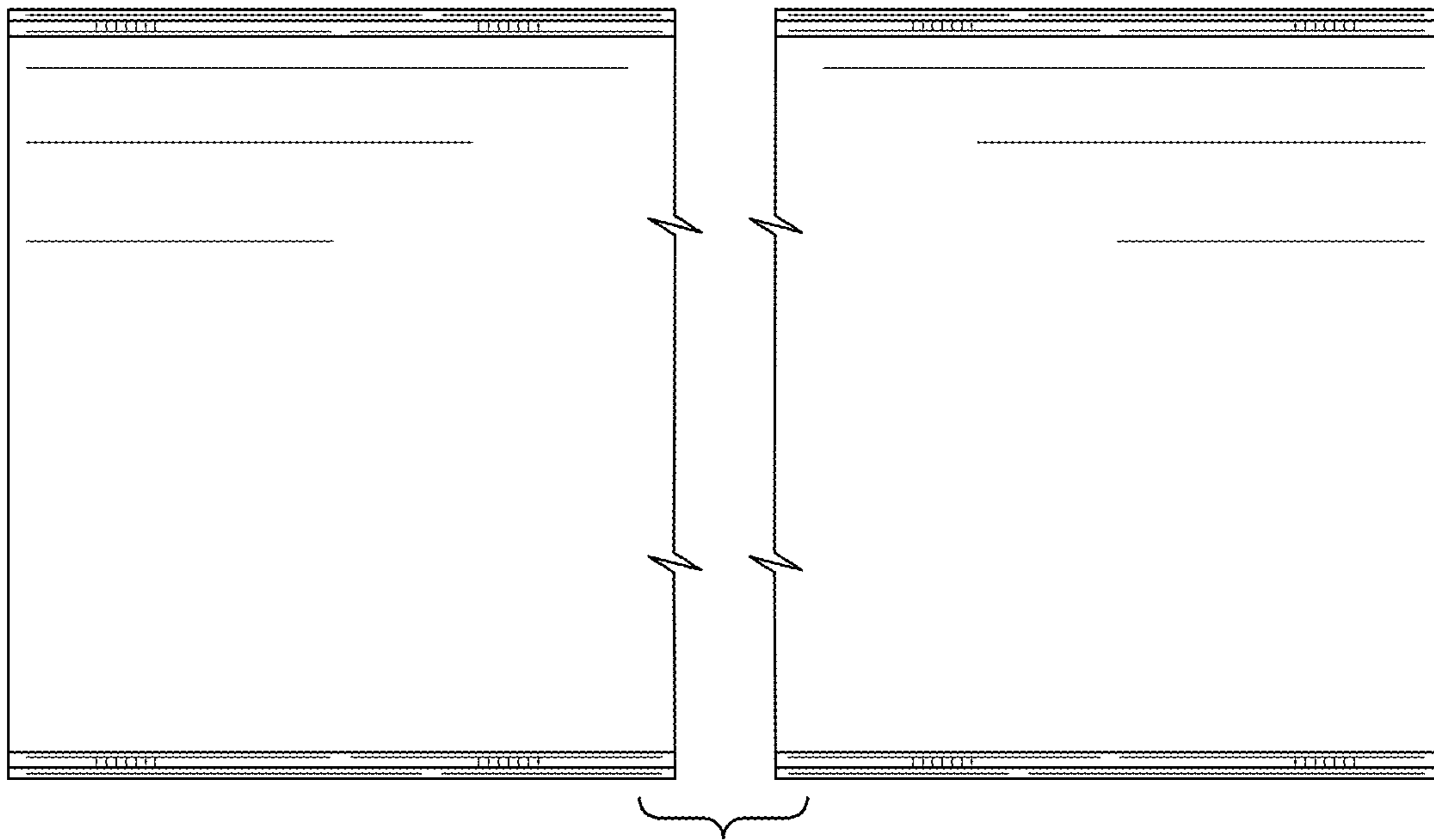

FIG. 7

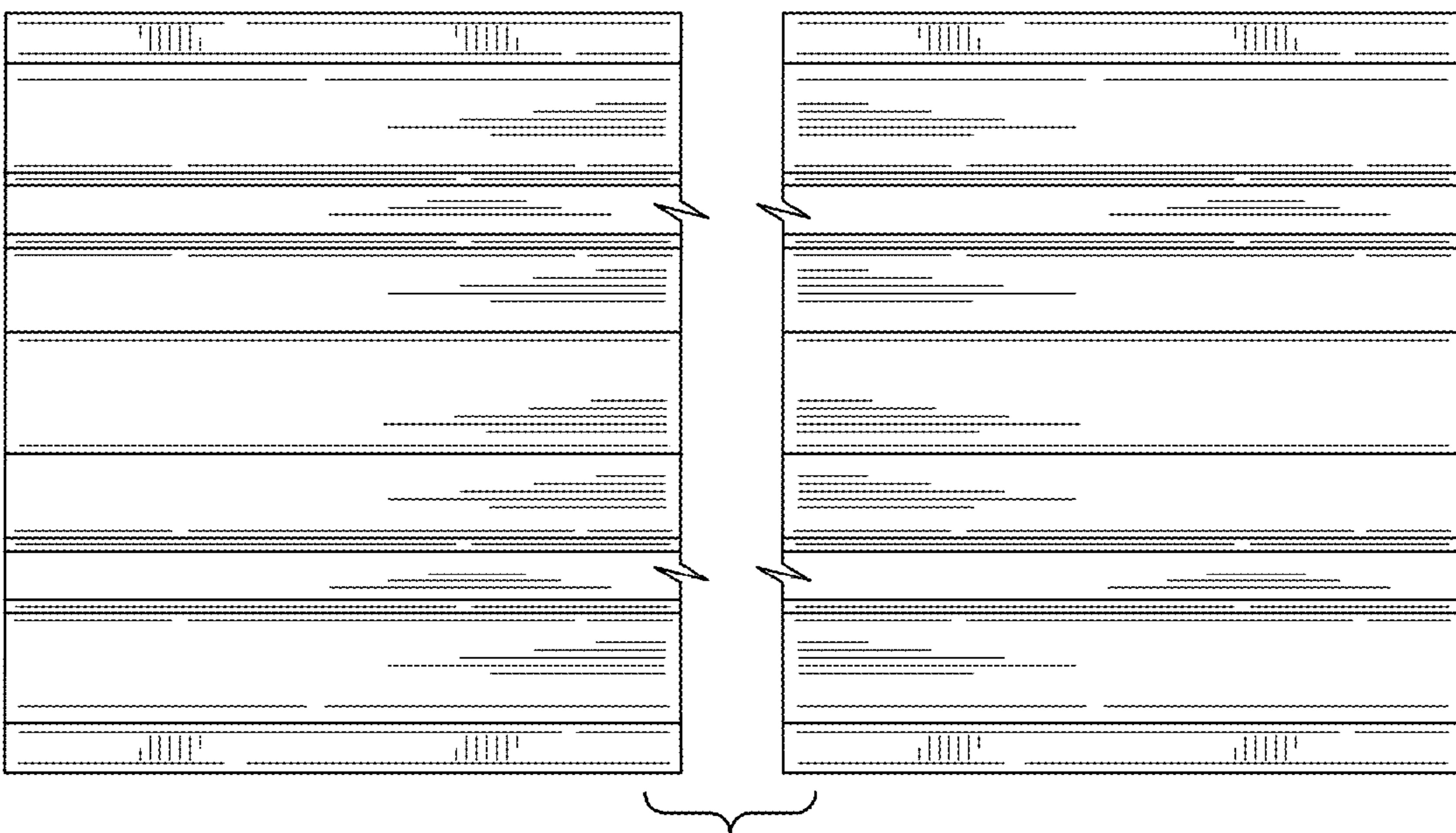

FIG. 8

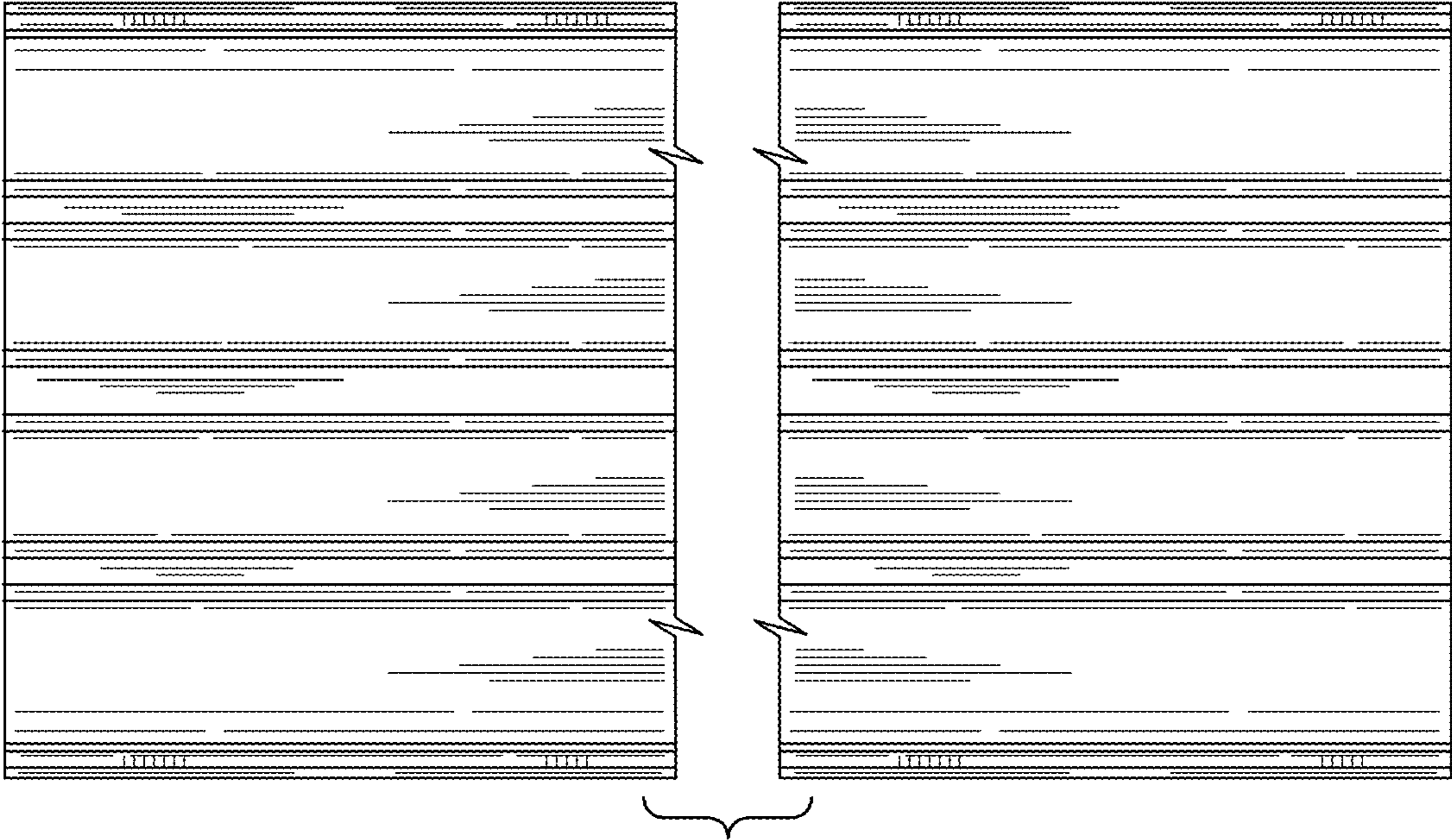

FIG. 9

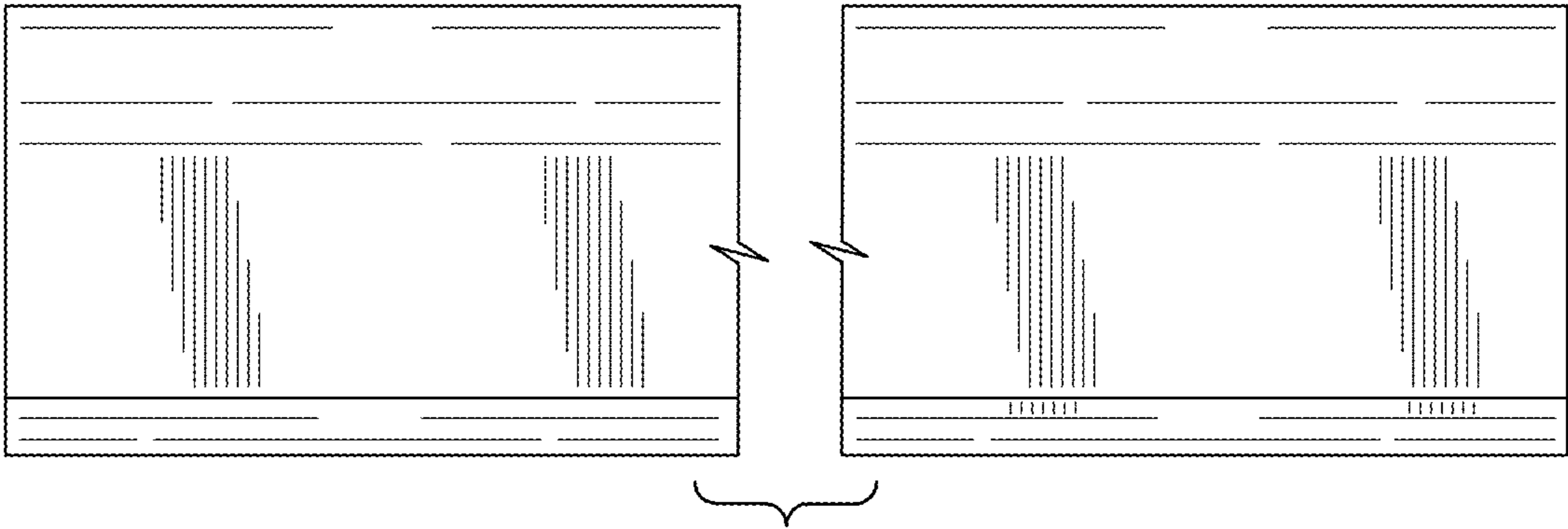

FIG. 10

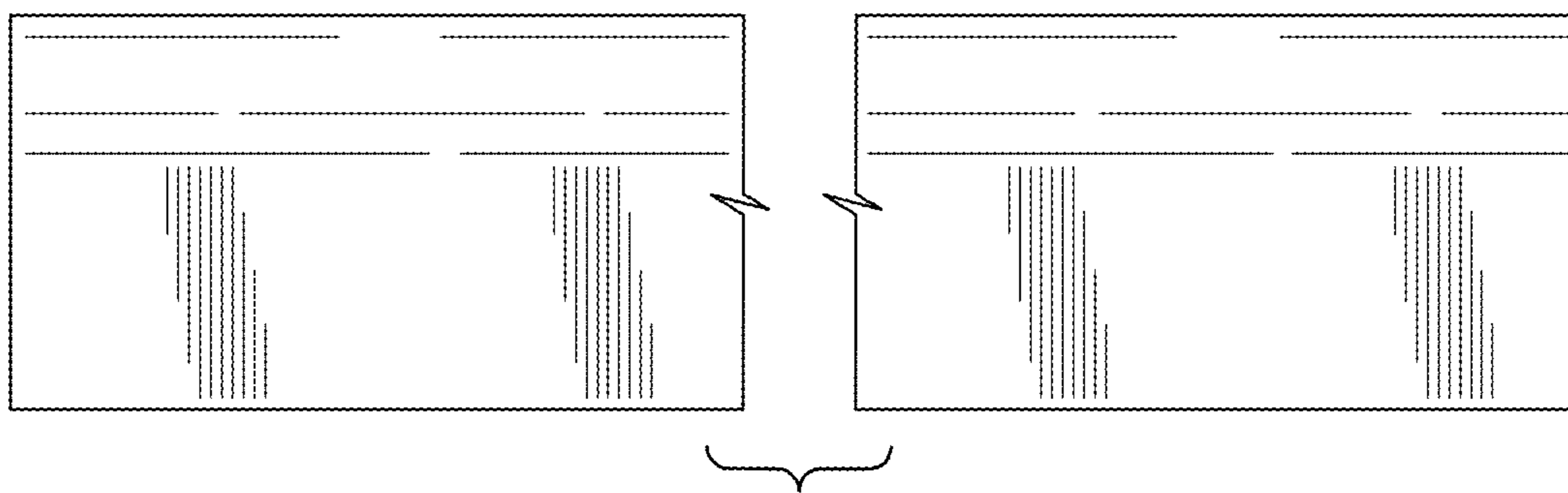

FIG. 11

