



US00D770942S

(12) **United States Design Patent** (10) **Patent No.:** **US D770,942 S**  
**Woodhouse et al.** (45) **Date of Patent:** **\*\* Nov. 8, 2016**

- (54) **VEHICLE EXTERIOR**
- (71) Applicant: **Ford Motor Company**, Dearborn, MI (US)
- (72) Inventors: **David Woodhouse**, Troy, MI (US);  
**Shawn Wehrly**, Northville, MI (US);  
**Moray S Callum**, Ann Arbor, MI (US);  
**Max Wolff**, Birmingham, MI (US);  
**Kemal Curic**, West Bloomfield, MI (US)
- (73) Assignee: **Ford Motor Company**, Dearborn, MI (US)
- (\*\*) Term: **14 Years**
- (21) Appl. No.: **29/522,294**
- (22) Filed: **Mar. 30, 2015**
- (51) **LOC (10) Cl.** ..... **12-08**
- (52) **U.S. Cl.**  
USPC ..... **D12/92**
- (58) **Field of Classification Search**  
USPC ..... D12/86, 90-92, 88; D21/421, 433, 434;  
296/181.1, 181.5  
CPC ..... B62D 35/00; B62D 25/00; B62D 25/06;  
B62D 33/00  
See application file for complete search history.

D528,943 S *	9/2006	Otsubo .....	D12/90
D531,548 S *	11/2006	Hagino .....	D12/92
D537,383 S *	2/2007	Kato .....	D12/91
D564,414 S *	3/2008	Okue .....	D12/92
D599,706 S *	9/2009	Tanaka .....	D12/92
D603,297 S *	11/2009	Takahashi .....	D12/92
D630,555 S *	1/2011	Koshino .....	D12/92
D649,911 S *	12/2011	Okumoto .....	D12/92
D686,531 S *	7/2013	Lamm .....	D12/91
D718,661 S *	12/2014	Tabata .....	D12/91
D727,211 S *	4/2015	Rupar .....	D12/91
D741,228 S *	10/2015	Curic .....	D12/92

\* cited by examiner

*Primary Examiner* — Melody N Brown

(74) *Attorney, Agent, or Firm* — Damian Porcari

(57) **CLAIM**

The ornamental design for a vehicle exterior, as shown and described.

**DESCRIPTION**

FIG. 1 is a front and left perspective view of a vehicle exterior;  
FIG. 2 is a rear and left perspective view thereof;  
FIG. 3 is a front elevational view thereof;  
FIG. 4 is a rear elevational view thereof;  
FIG. 5 is a left side elevational view thereof;  
FIG. 6 is a right side elevational view thereof; and,  
FIG. 7 is a top plan view thereof.

**1 Claim, 7 Drawing Sheets**

(56) **References Cited**

**U.S. PATENT DOCUMENTS**

D500,710 S *	1/2005	Saito .....	D12/92
D525,174 S *	7/2006	Minowa .....	D12/92

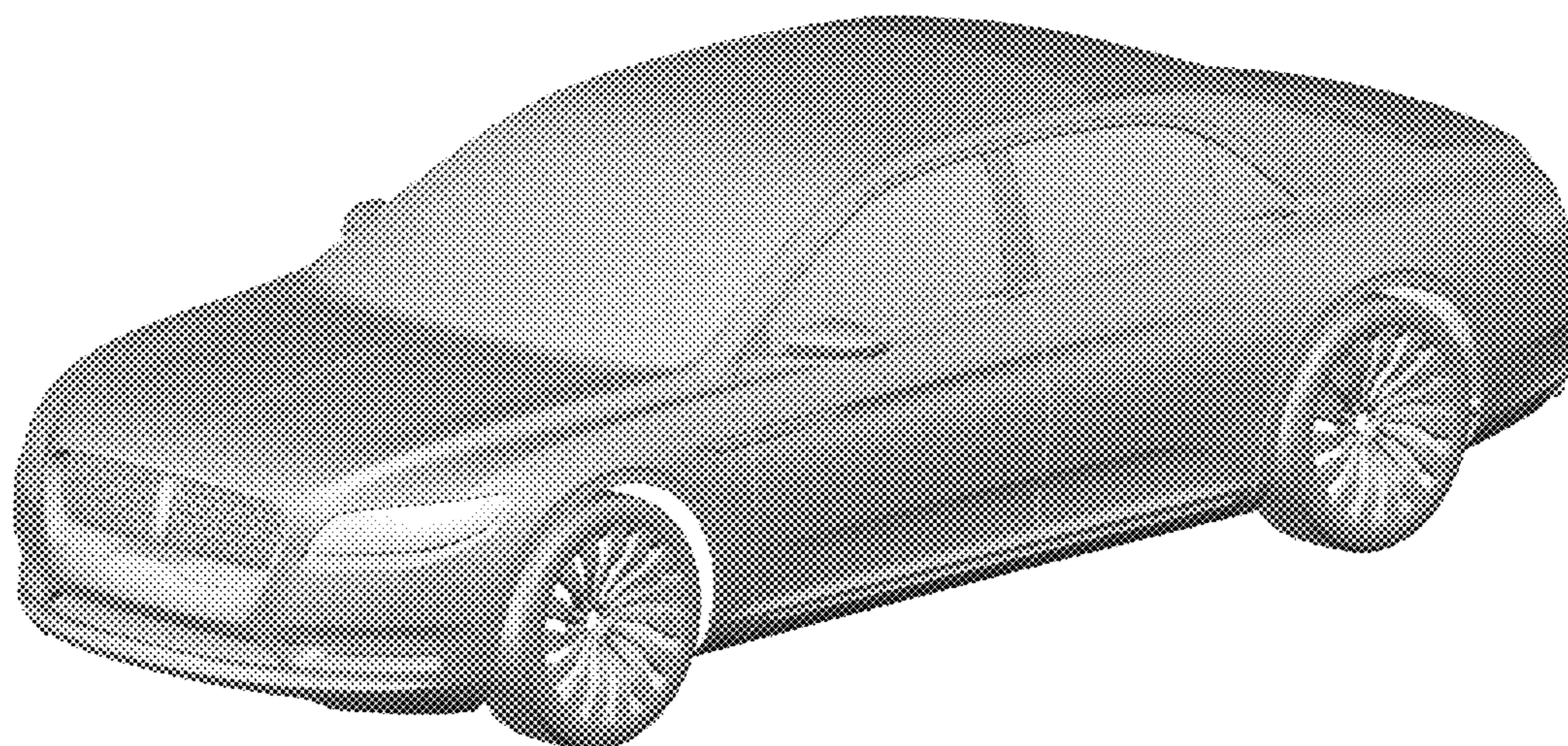



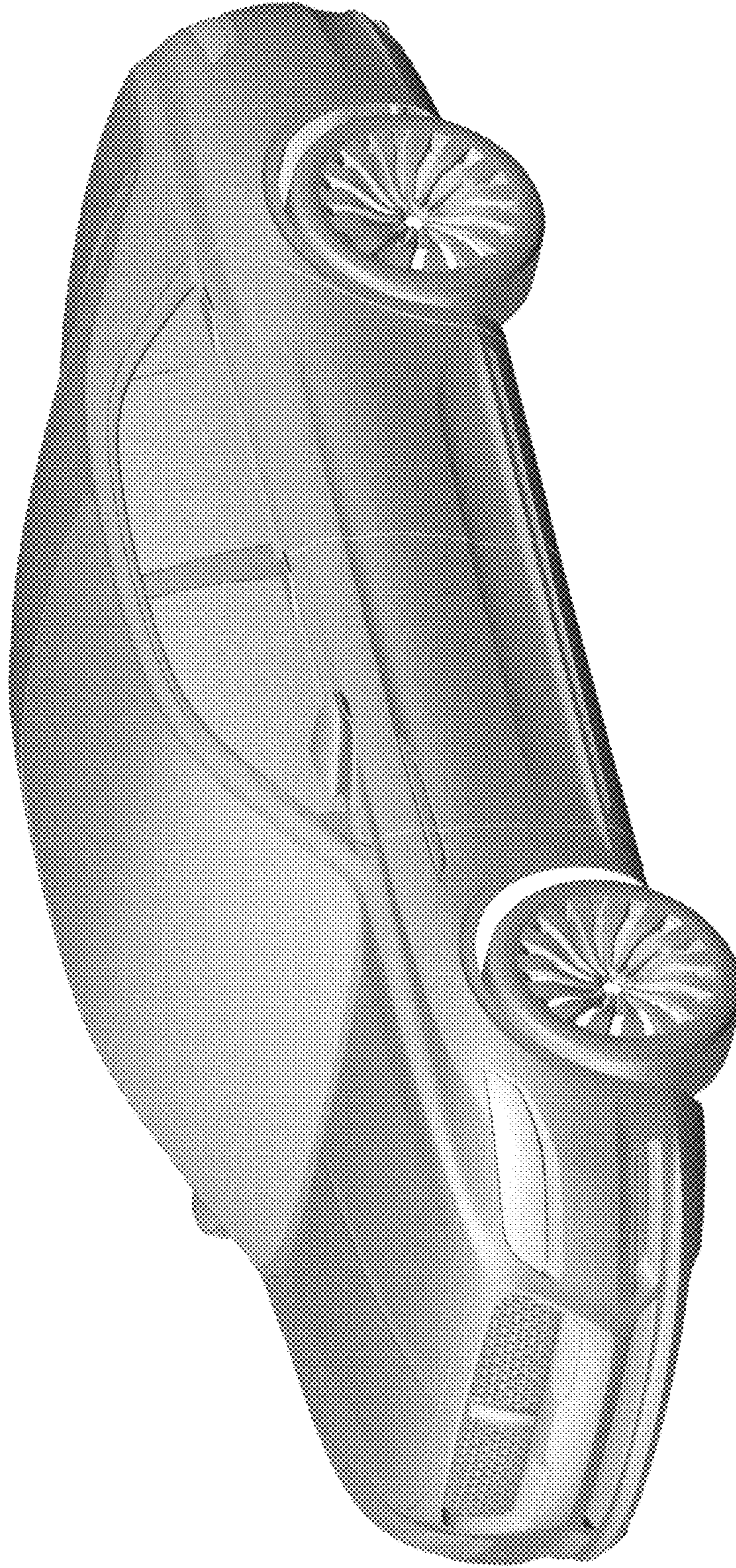

Figure 1



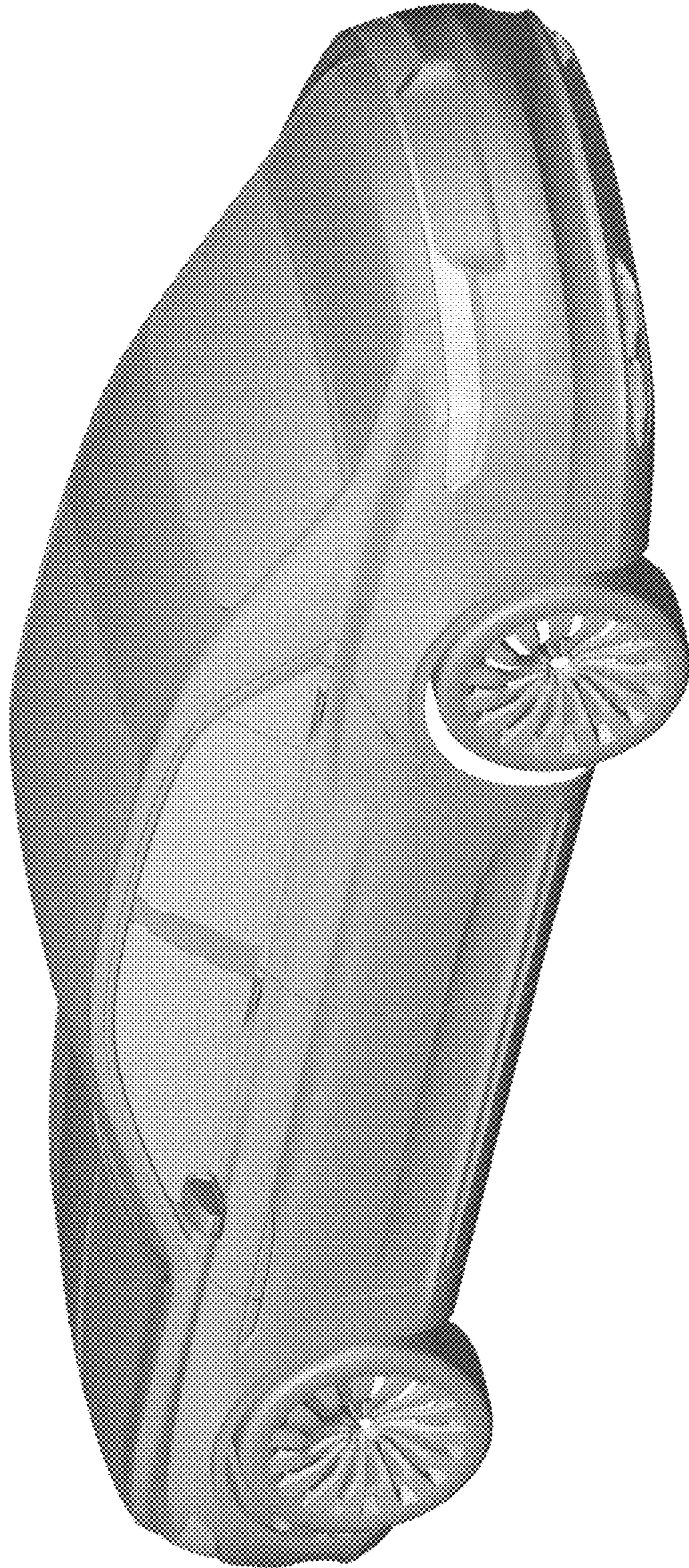
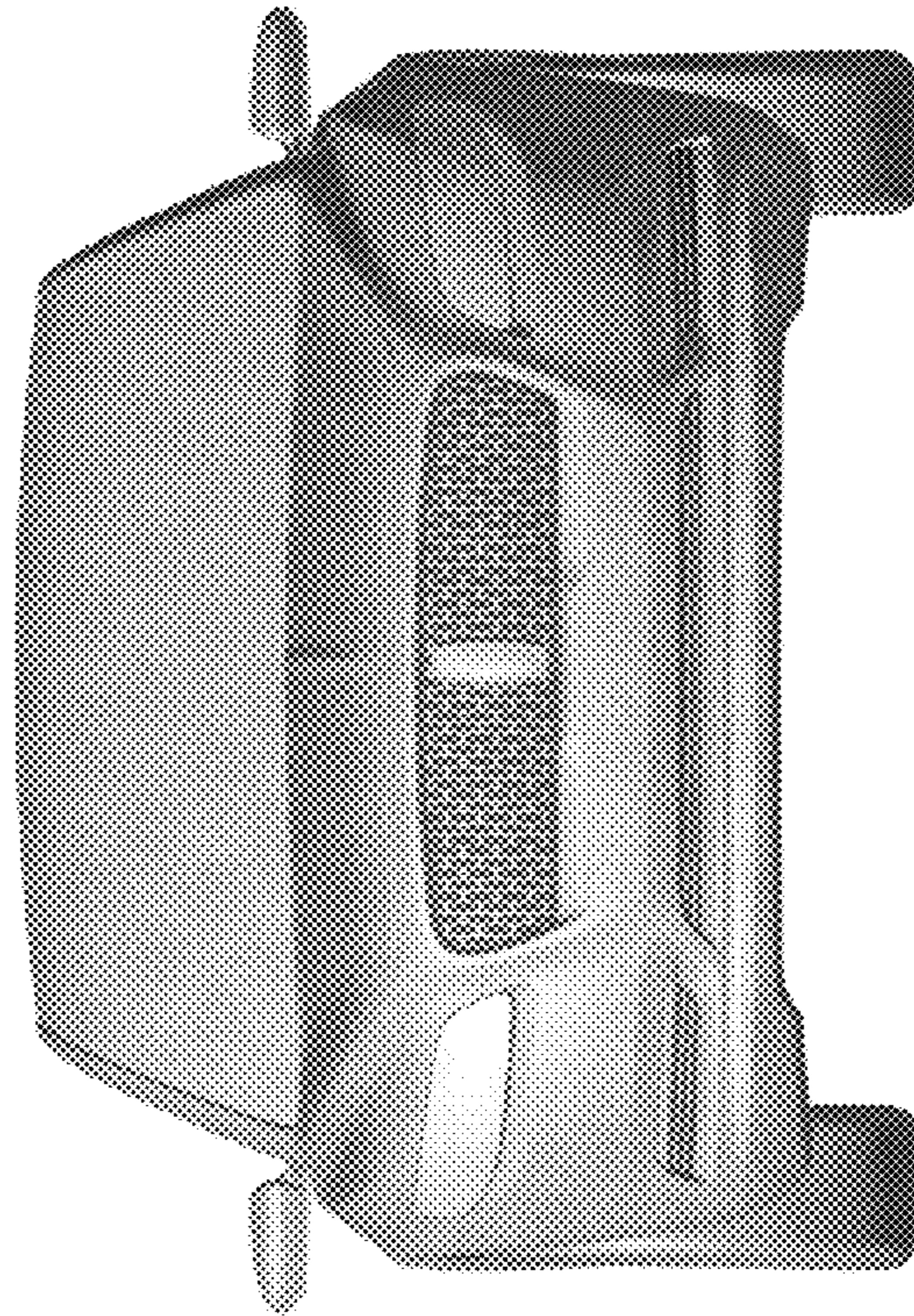

Figure 2





*Figure 3*

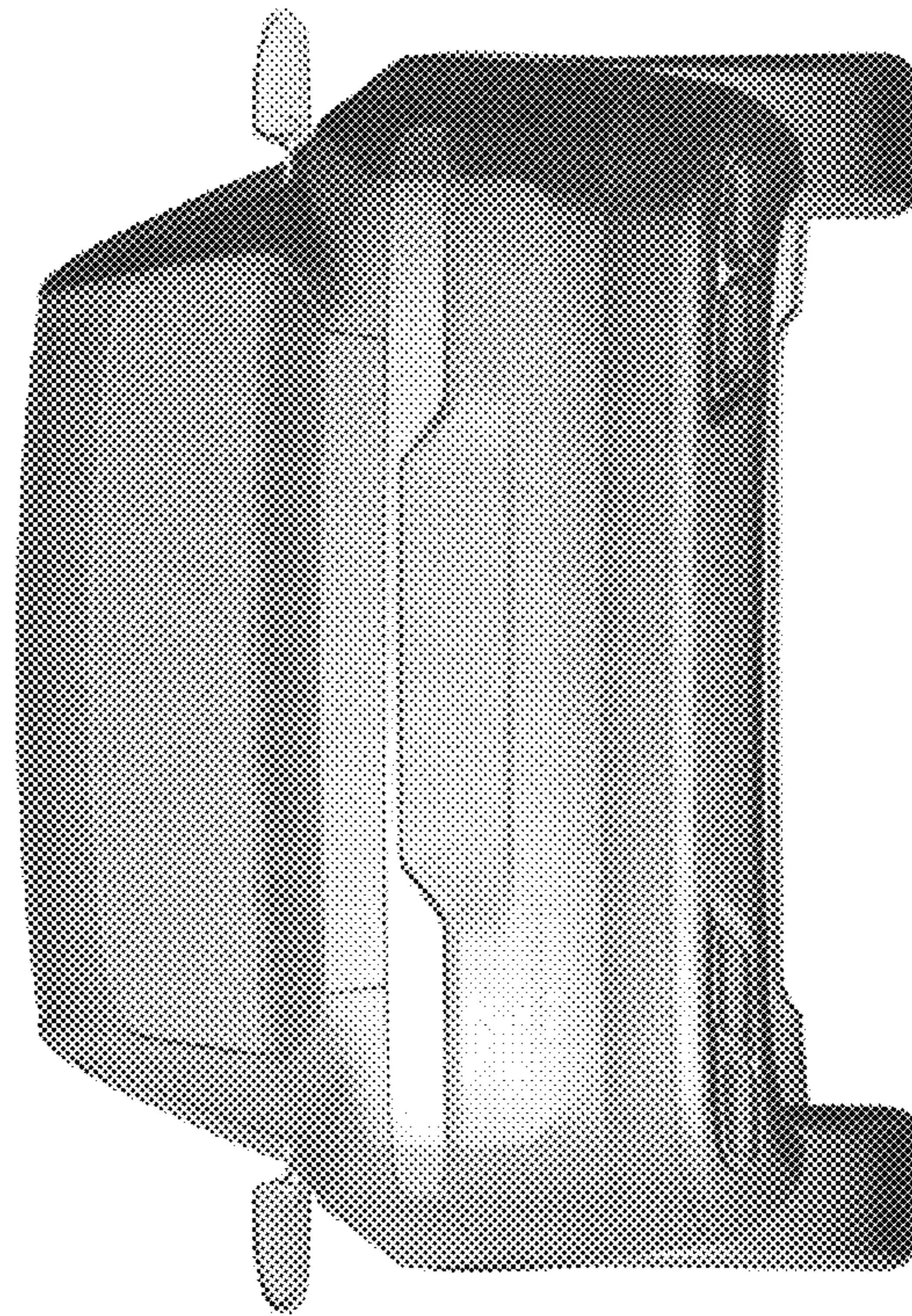

Figure 4



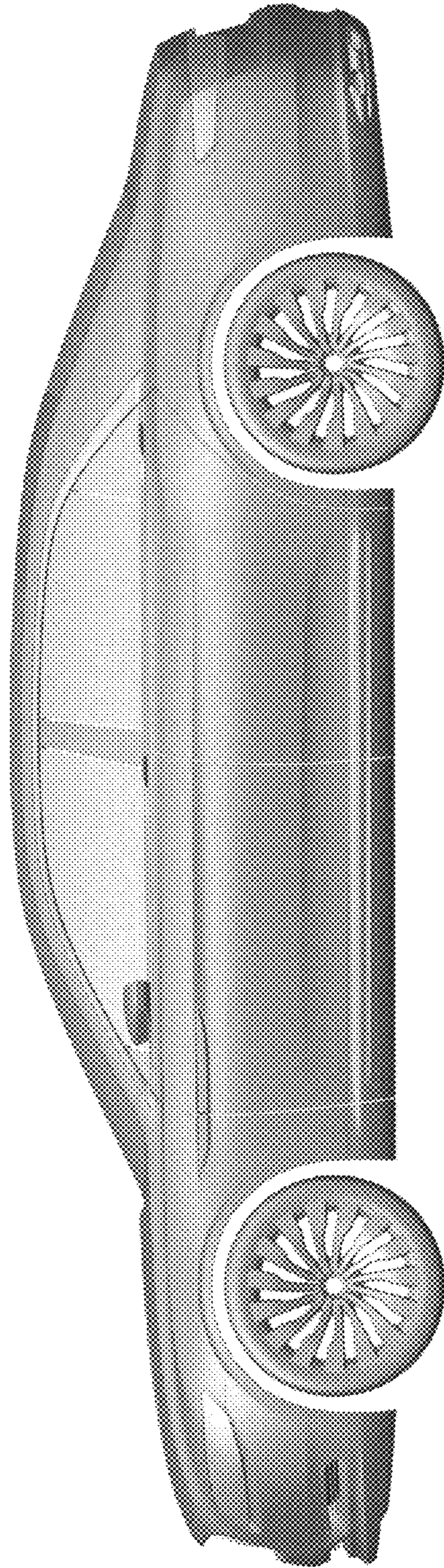

Figure 5



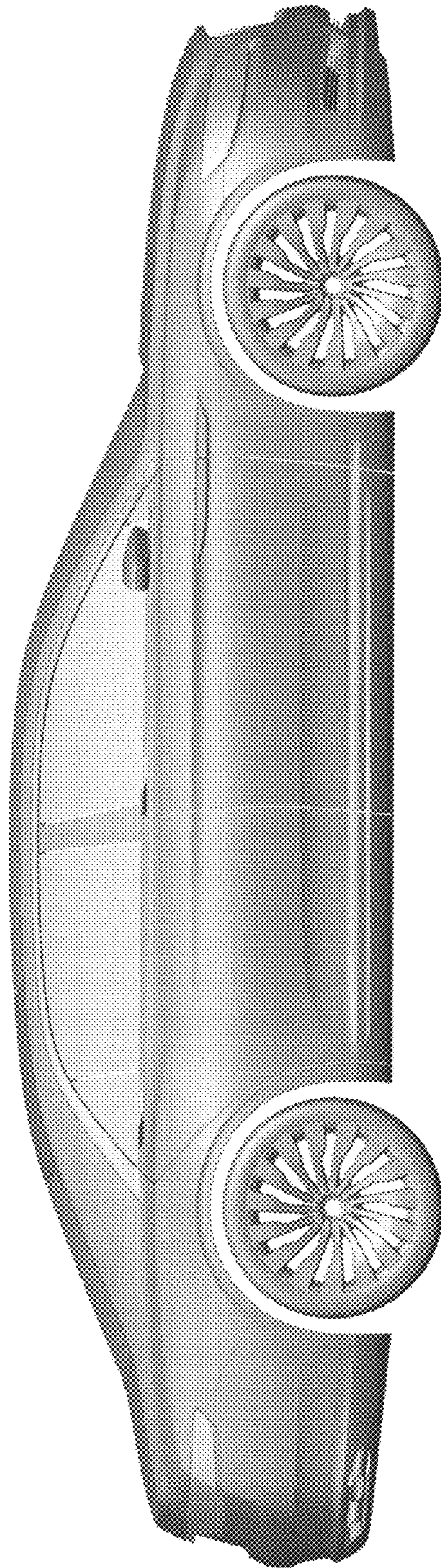

Figure 6





Figure 7