



US00D770877S

(12) **United States Design Patent** (10) **Patent No.:** **US D770,877 S**
Pitchforth et al. (45) **Date of Patent:** **** Nov. 8, 2016**

(54) **LUGGAGE HANDLE**
(71) Applicant: **Eddie Bauer LLC**, Bellevue, WA (US)
(72) Inventors: **Noah Pitchforth**, Issaquah, WA (US);
Jesse Thompson, North Bend, WA (US); **Brian Fletcher**, North Bend, WA (US)
(73) Assignee: **Eddie Bauer LLC**, Bellevue, WA (US)
(**) Term: **14 Years**
(21) Appl. No.: **29/488,345**
(22) Filed: **Apr. 17, 2014**
(51) **LOC (10) Cl.** **08-06**
(52) **U.S. Cl.**
USPC **D8/317; D3/246**
(58) **Field of Classification Search**
USPC D8/300, 317, 318, 321, 303, 349;
D3/243, 246; 16/110.1, 114.1, 406,
16/435, 443, 444, DIG. 12, DIG. 18,
16/DIG. 24, DIG. 25; 190/118, 119, 121,
190/115, 116; 383/6, 7, 12, 16, 17, 22, 24;
220/755
CPC A45F 5/00; A45F 5/10; A45F 5/102;
A45F 5/1033; B65D 33/06; B65D 33/14;
B65D 71/00
See application file for complete search history.

(56) **References Cited**
U.S. PATENT DOCUMENTS
1,268,775 A 6/1918 Stanger
2,425,245 A 8/1947 Johnson
2,444,558 A 7/1948 Elliott
3,083,366 A * 3/1963 Franges A45F 5/1046
294/171
3,680,752 A 8/1972 Wilson
3,800,361 A * 4/1974 Stauffer A45F 5/10
16/411
4,791,702 A * 12/1988 McVey A45F 5/10
16/428
4,902,060 A * 2/1990 Nobakht A45F 5/1046
16/411

4,923,235 A * 5/1990 Stewart A45F 5/1046
294/141
4,936,619 A * 6/1990 Salazar A45F 5/1046
294/171
5,029,926 A 7/1991 Dieterich, Jr.
D319,962 S * 9/1991 Cousins D8/306
5,279,443 A * 1/1994 Koda B65D 25/30
206/203
5,560,083 A * 10/1996 Teixeira A45C 13/26
16/411
5,996,180 A 12/1999 Eisenzopf
D419,853 S * 2/2000 Workman D8/317
6,049,948 A 4/2000 Leonardi
6,167,592 B1 * 1/2001 Tsai A45C 13/26
16/411
6,290,040 B1 9/2001 Chen
6,338,180 B1 1/2002 Massard
D456,455 S * 4/2002 Cleveland D20/27
D637,816 S * 5/2011 Nitkin D3/318
2003/0009847 A1 1/2003 Godshaw et al.

(Continued)

OTHER PUBLICATIONS

International Search Report and Written Opinion for International (PCT) Patent Application No. PCT/US15/26360, mailed Jul. 20, 2015 15 pages.
Official Action for U.S. Appl. No. 14/689,459, mailed Oct. 19, 2015 18 pages.

(Continued)

Primary Examiner — Prabhakar Deshmukh
(74) *Attorney, Agent, or Firm* — Sheridan Ross P.C.

(57) **CLAIM**
The ornamental design for a luggage handle, as shown and described.

DESCRIPTION

FIG. 1 is a front perspective view of a luggage handle; FIG. 2 is a front elevation view thereof; FIG. 3 is a rear elevation view thereof; FIG. 4 is a right elevation view thereof; FIG. 5 is a left elevation view thereof; FIG. 6 is a top plan view thereof; and, FIG. 7 is a bottom plan view thereof. The broken lines illustrate environment and forms no part of the claimed design.

1 Claim, 3 Drawing Sheets

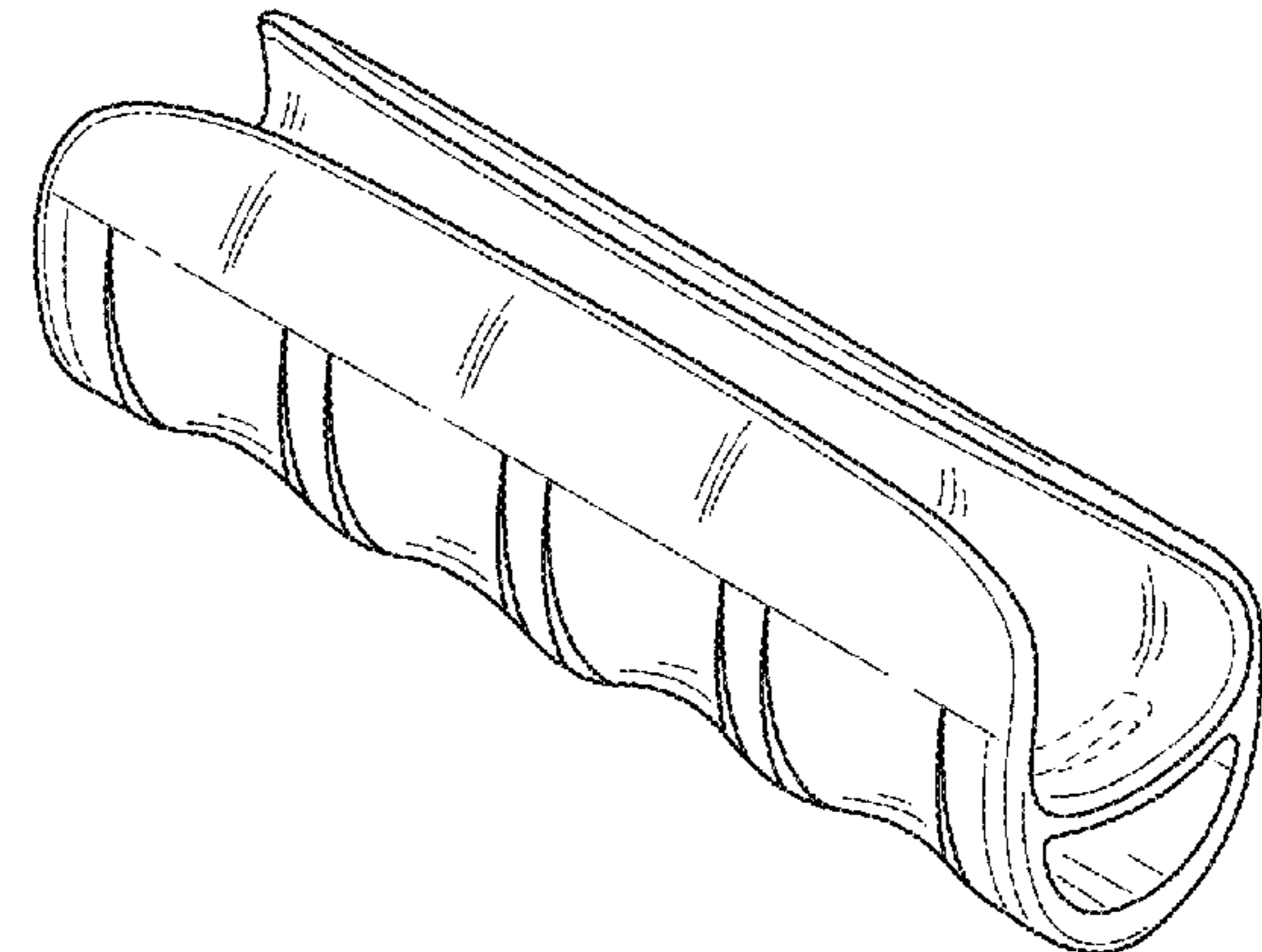

(56)

References Cited

U.S. PATENT DOCUMENTS

2006/0137950	A1	6/2006	Nassanian
2006/0163894	A1	7/2006	Mishek et al.
2007/0000089	A1	1/2007	Morales
2008/0260300	A1	10/2008	Zabian
2010/0052349	A1	3/2010	Naeve et al.
2011/0000942	A1	1/2011	Slockbower

OTHER PUBLICATIONS

“Silicon Handle,” oempromo.com, Feb. 12, 2014, available at www.oempromo.com/product.Handles/S/Silicon-Handle-264984.html, 1 page.

Notice of Allowance with English Translation for Japan Patent Application No. 2014/023289, mailed Jan. 23, 2015 2 pages.

U.S. Appl. No. 14/689,459, filed Apr. 17, 2015, Pitchforth et al.

* cited by examiner

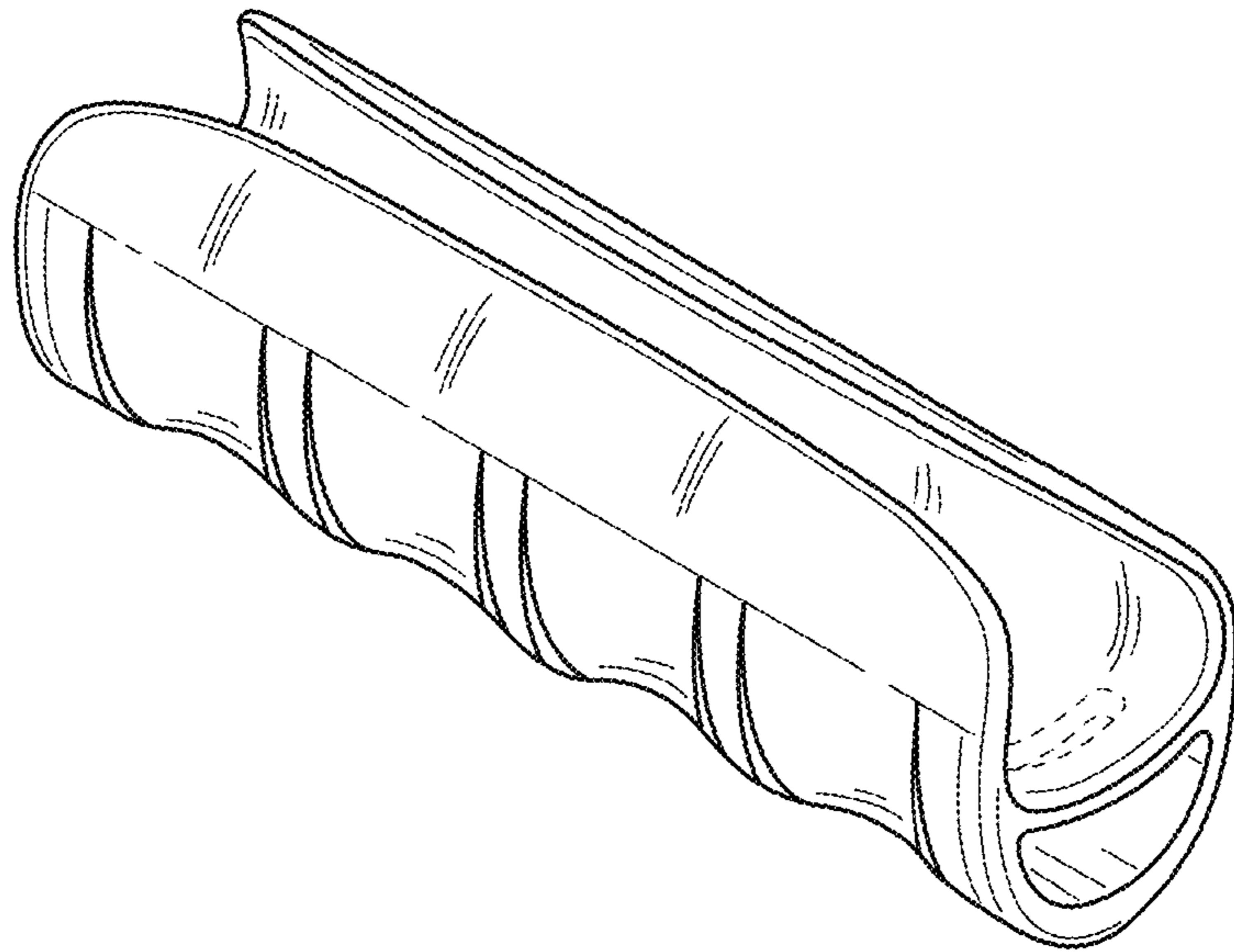

FIG.1

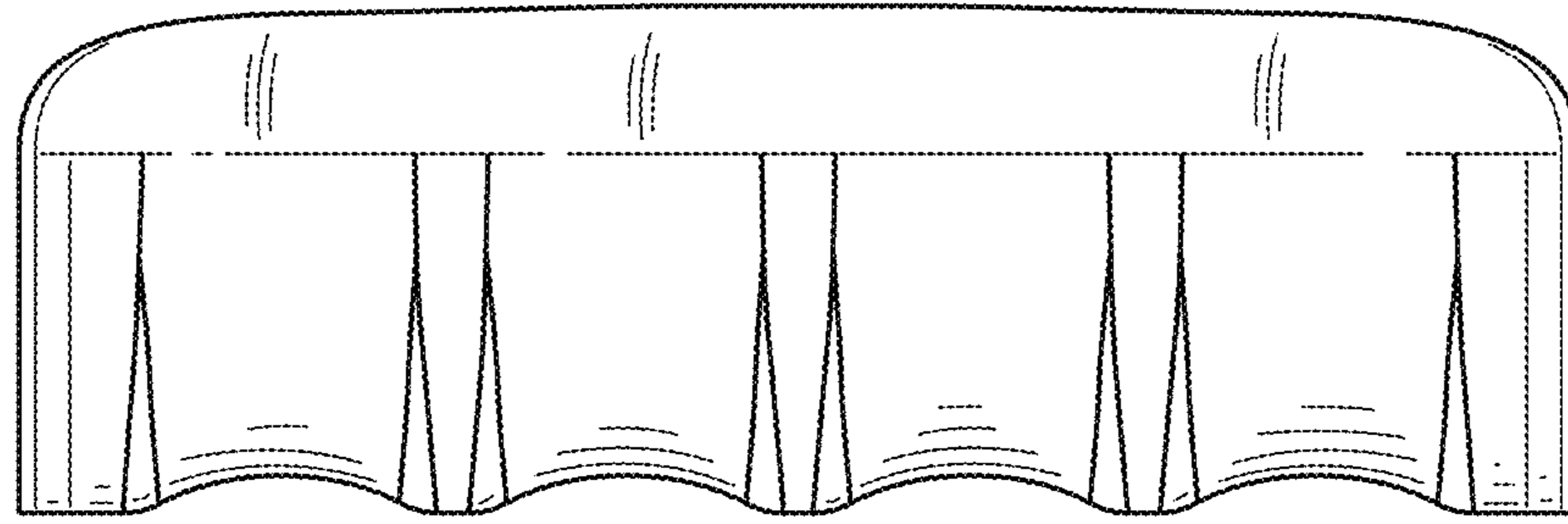

FIG. 2

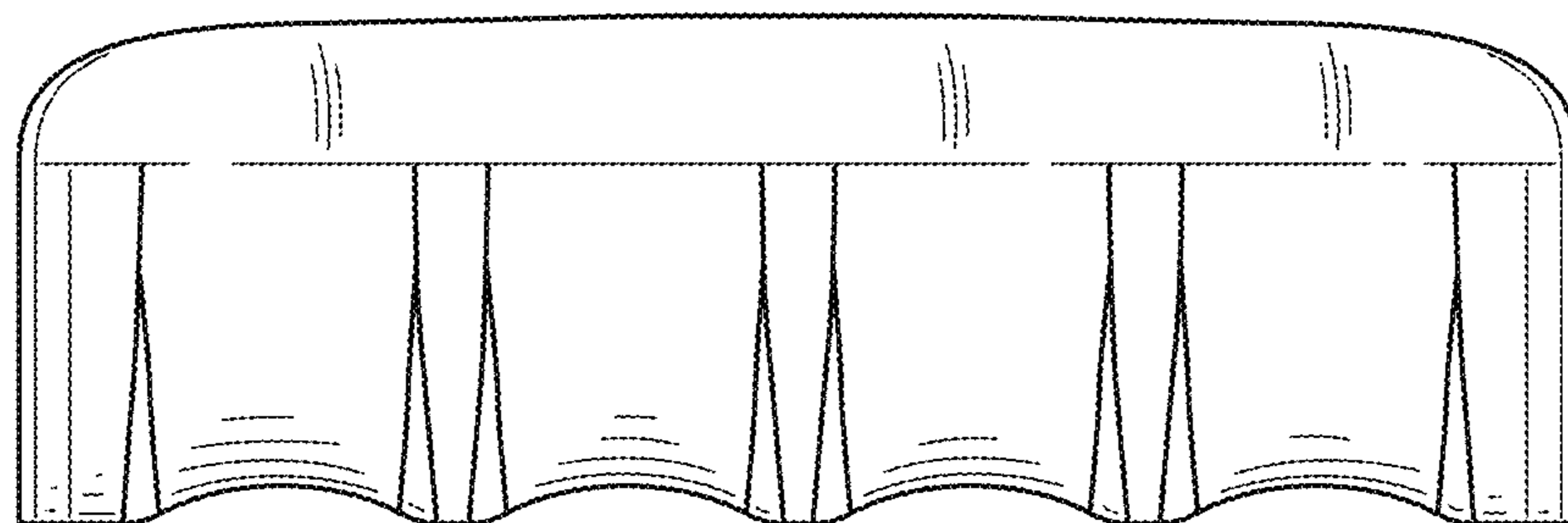

FIG. 3

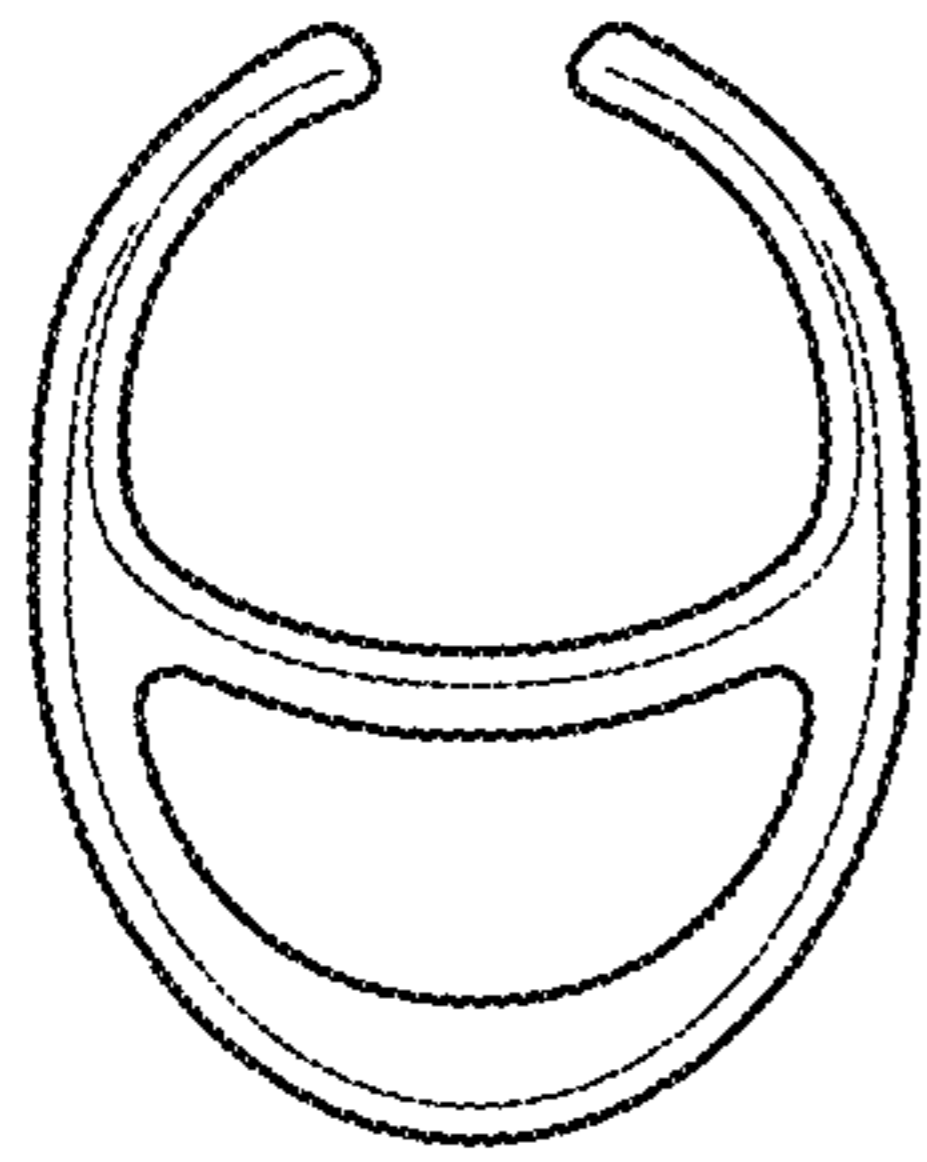

FIG. 4

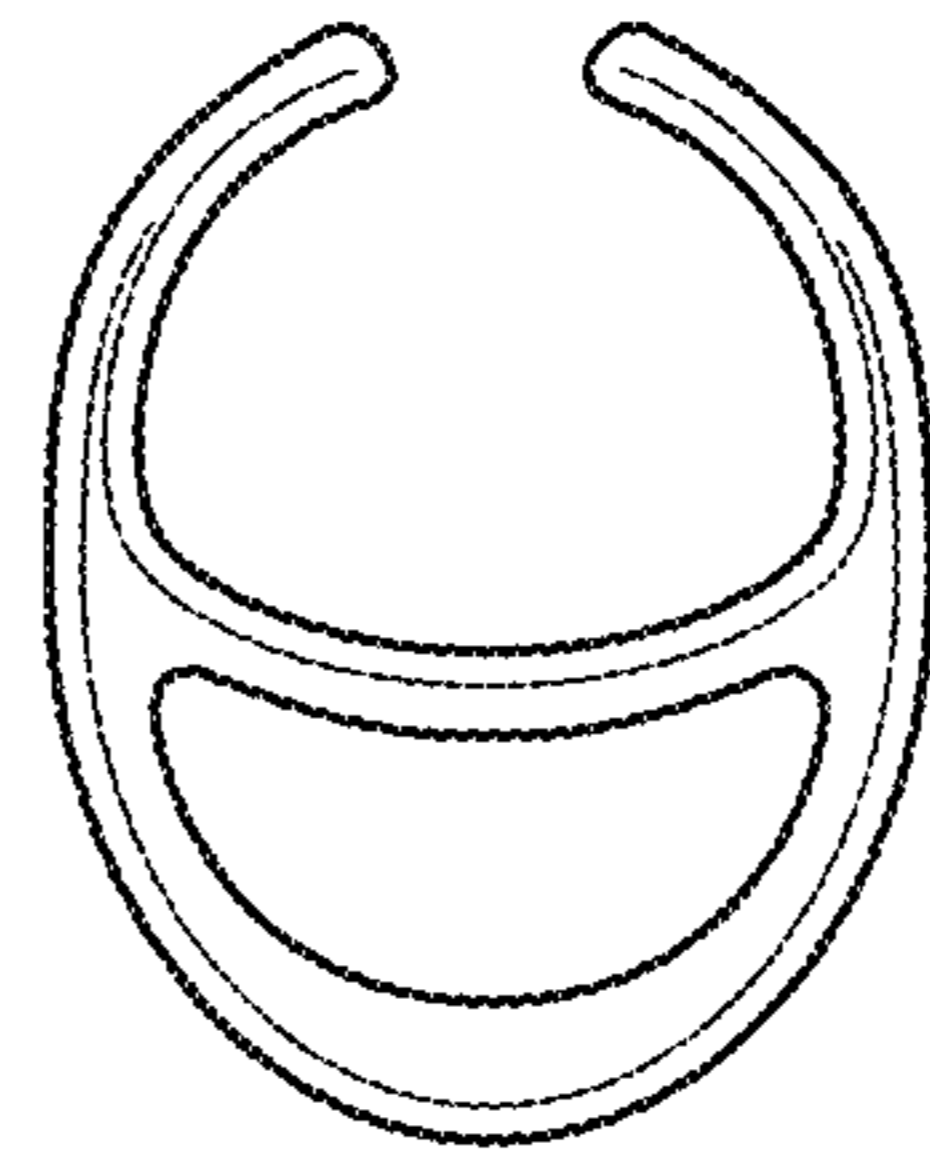

FIG. 5

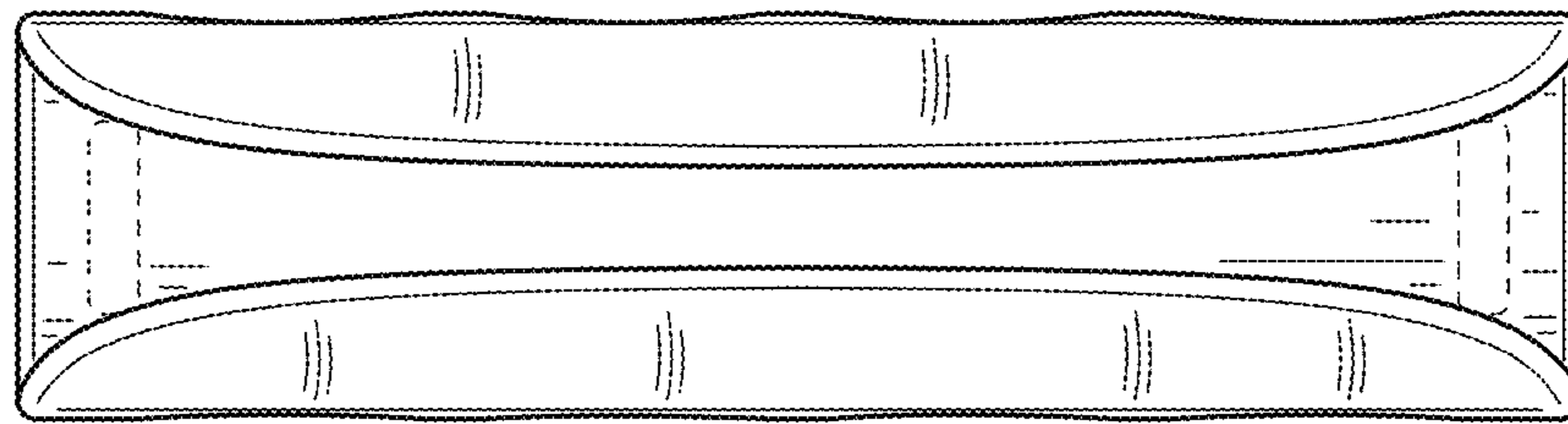

FIG. 6

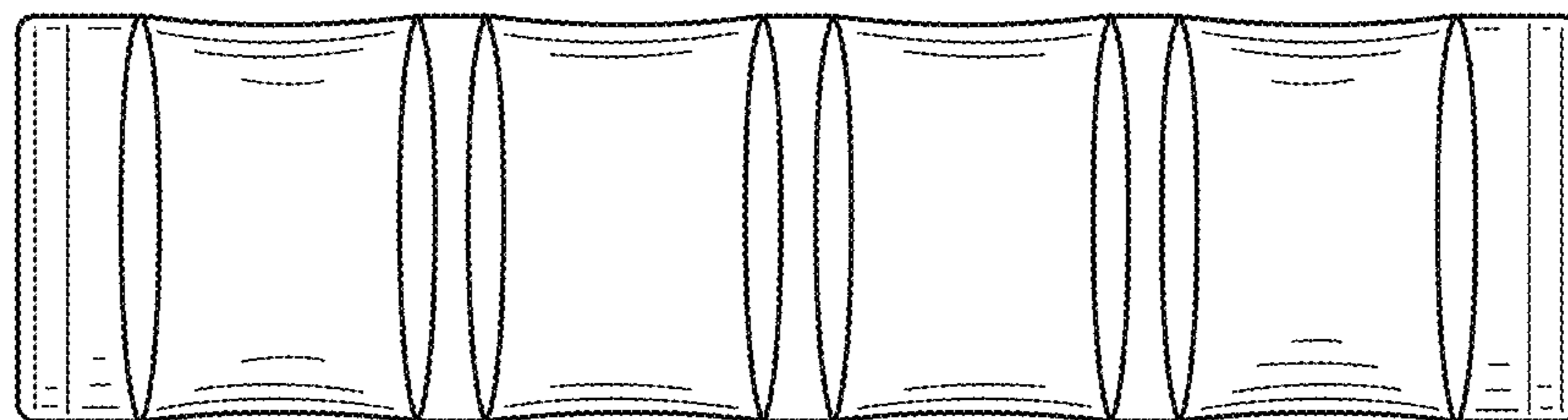

FIG. 7