



US00D770356S

(12) **United States Design Patent**  
**Chantal et al.**

(10) **Patent No.:** **US D770,356 S**  
(45) **Date of Patent:** **\*\* Nov. 1, 2016**

- (54) **HANDRAIL FOR AN AIRCRAFT CABIN**
- (71) Applicant: **Airbus Corporate Jet Centre**,  
Toulouse (FR)
- (72) Inventors: **Beranger Chantal**, Toulouse (FR);  
**Sylvain Mariat**, Toulouse (FR); **Pascal Taffarello**, Colomiers (FR)
- (73) Assignee: **Airbus Corporate Jet Centre**,  
Toulouse (FR)
- (\*\*) Term: **14 Years**
- (21) Appl. No.: **29/497,055**
- (22) Filed: **Jul. 21, 2014**
- (30) **Foreign Application Priority Data**

Apr. 30, 2014 (EM) ..... 001410252

(51) **LOC (10) Cl.** ..... **12-07**

(52) **U.S. Cl.**  
USPC ..... **D12/345**

(58) **Field of Classification Search**  
USPC ..... D6/336, 384, 653, 654, 665, 657, 663,  
D6/672, 573; D7/602, 603, 614; D12/319,  
D12/323, 325, 336, 345, 192, 423, 415, 416,  
D12/179, 180, 182; D21/436, 447, 448,  
D21/449, 453; D13/184; D15/81, 91  
CPC ..... B64C 13/04; B64D 11/0007; B64D  
11/0015; B64D 11/003; B64D 11/04; B64D  
2011/0046; B64D 11/0629; B64B 1/10  
See application file for complete search history.

(56) **References Cited**

**U.S. PATENT DOCUMENTS**

- D128,507 S \* 7/1941 Stewart ..... 211/134
- 2,251,050 A \* 7/1941 Stewart ..... B60Q 3/025  
105/325
- 2,263,919 A \* 11/1941 Darragh, Jr. .... B64C 1/066  
181/207

- D256,229 S \* 8/1980 Nichols ..... D12/418
- D281,930 S \* 12/1985 Engfer ..... D12/195
- 5,988,565 A \* 11/1999 Thomas ..... B64D 11/003  
244/118.1
- 6,290,175 B1 \* 9/2001 Hart ..... B64D 11/003  
244/118.1
- D463,357 S \* 9/2002 Granzeier ..... D12/345
- 7,380,752 B2 \* 6/2008 Guard ..... B64C 1/066  
244/118.5

(Continued)

*Primary Examiner* — Robert M Spear  
*Assistant Examiner* — Marissa J Cash  
(74) *Attorney, Agent, or Firm* — Greer, Burns & Crain,  
Ltd.

(57) **CLAIM**

The ornamental design for a handrail for an aircraft cabin, as shown and described.

**DESCRIPTION**

FIG. 1. is a front and side perspective view of a handrail for an aircraft cabin;  
FIG. 2 is a top and side perspective view thereof;  
FIG. 3 is a bottom and side perspective view thereof;  
FIG. 4 is a top plan view thereof;  
FIG. 5 is a side elevational view thereof, the opposite side being a mirror image;  
FIG. 6. is a rear and side perspective view of a handrail for an aircraft cabin shown in an alternate environment of use;  
FIG. 7 is a front and side perspective view thereof;  
FIG. 8 is a bottom and side perspective view thereof;  
FIG. 9 is a top plan view thereof; and,  
FIG. 10 is a side elevational view thereof, the opposite side being a mirror image.  
The handrail for an aircraft is shown with a symbolic break in its length. The appearance of any portion of the article between the break lines forms no part of the claimed design. The broken lines in the drawings represent unclaimed environmental subject matter and form no part of the claim.

**1 Claim, 8 Drawing Sheets**

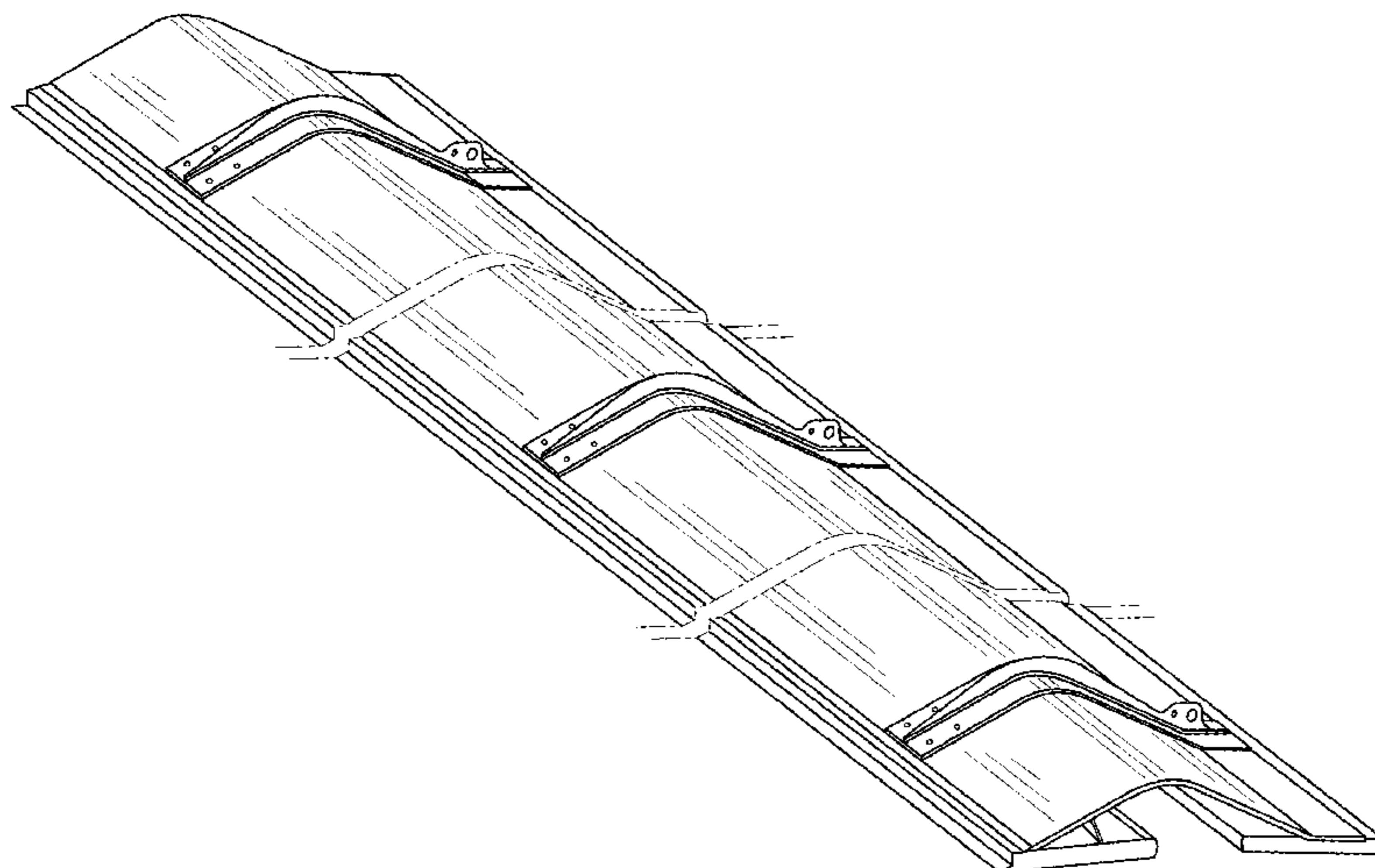

(56)

**References Cited**

U.S. PATENT DOCUMENTS

D638,341 S \* 5/2011 Schuephaus ..... D12/345  
 7,934,678 B2 \* 5/2011 Wieding ..... G05G 15/08  
 244/118.5  
 D690,255 S \* 9/2013 Schutterra ..... D12/345  
 8,657,231 B2 \* 2/2014 Burrows ..... B64D 11/003  
 244/118.1  
 8,955,805 B2 \* 2/2015 Savian ..... B60Q 3/022  
 244/118.5  
 D730,265 S \* 5/2015 Aruga ..... D12/345  
 D732,459 S \* 6/2015 Zuber ..... D12/345  
 D743,322 S \* 11/2015 Zuber ..... D12/345

D746,759 S \* 1/2016 Kammerer ..... D12/345  
 2002/0017002 A1 \* 2/2002 Sloan ..... B64F 1/305  
 14/71.1  
 2010/0243802 A1 \* 9/2010 Ehlers ..... B64D 11/003  
 244/118.5  
 2011/0253837 A1 \* 10/2011 Lee ..... B64D 11/003  
 244/118.5  
 2013/0208490 A1 \* 8/2013 Savian ..... B64D 11/0015  
 362/471  
 2015/0314873 A1 \* 11/2015 Mariat ..... B64C 1/18  
 362/471  
 2016/0009356 A1 \* 1/2016 Mariat ..... B64C 1/066  
 244/119

\* cited by examiner

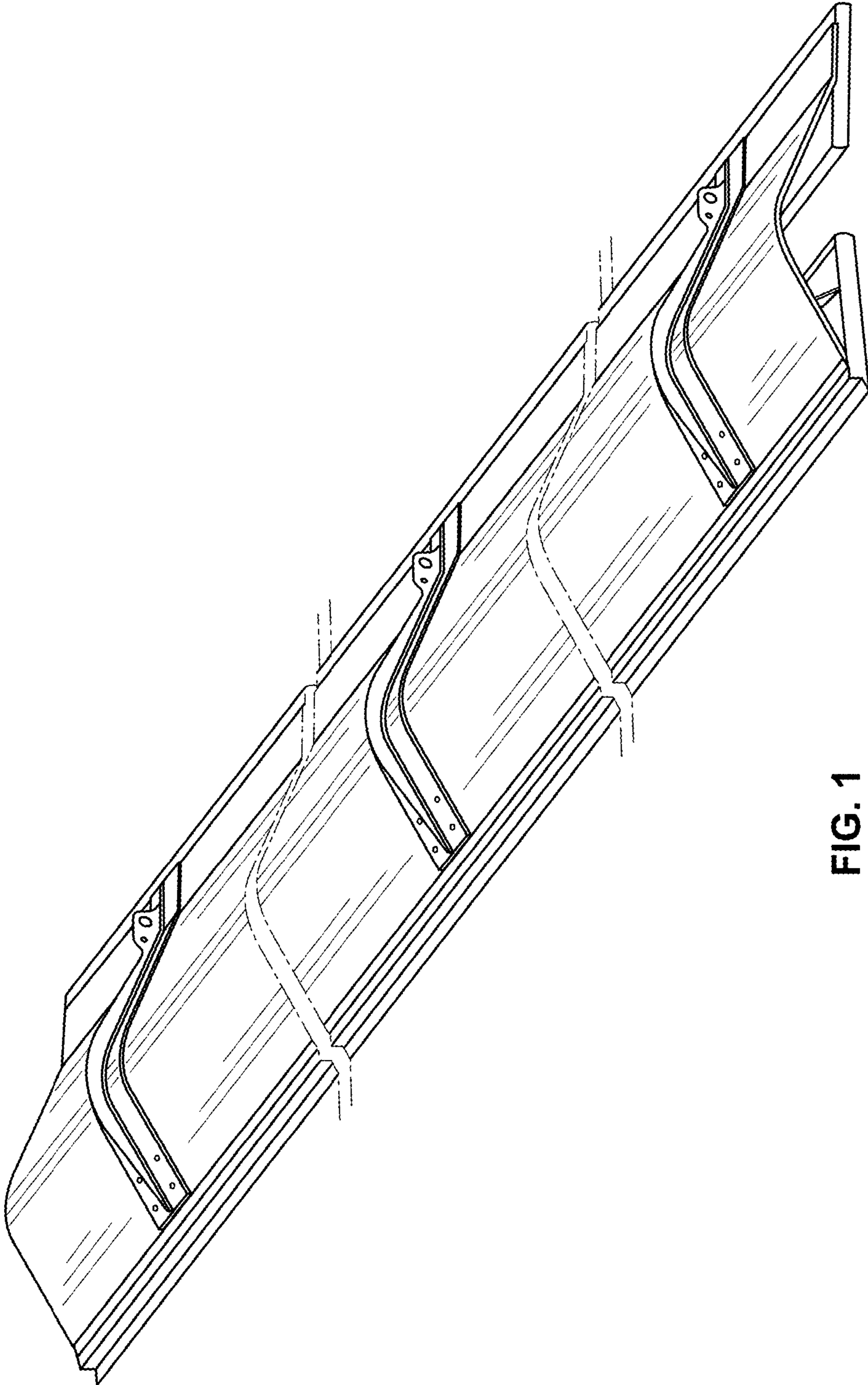

FIG. 1

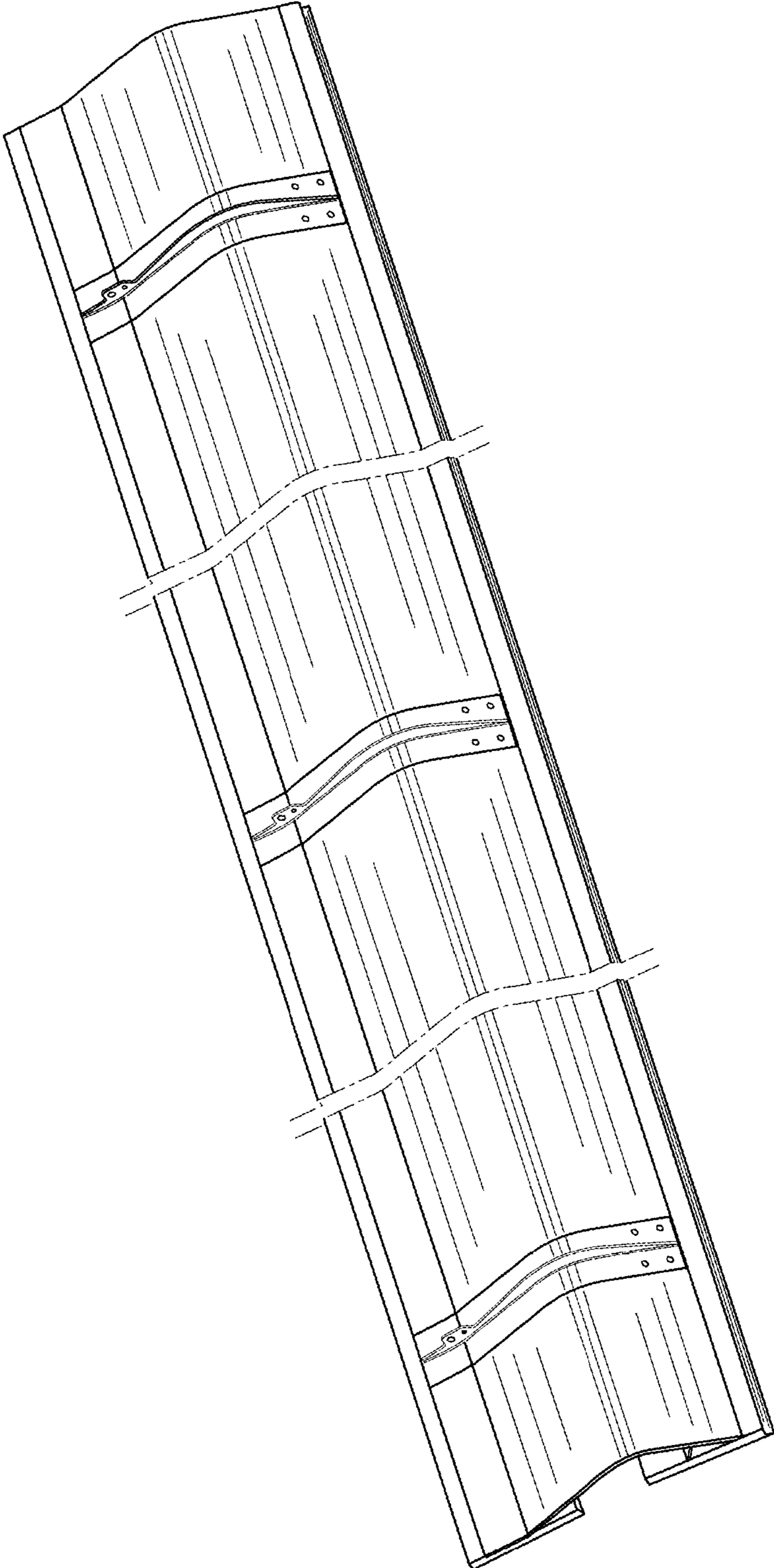

FIG. 2

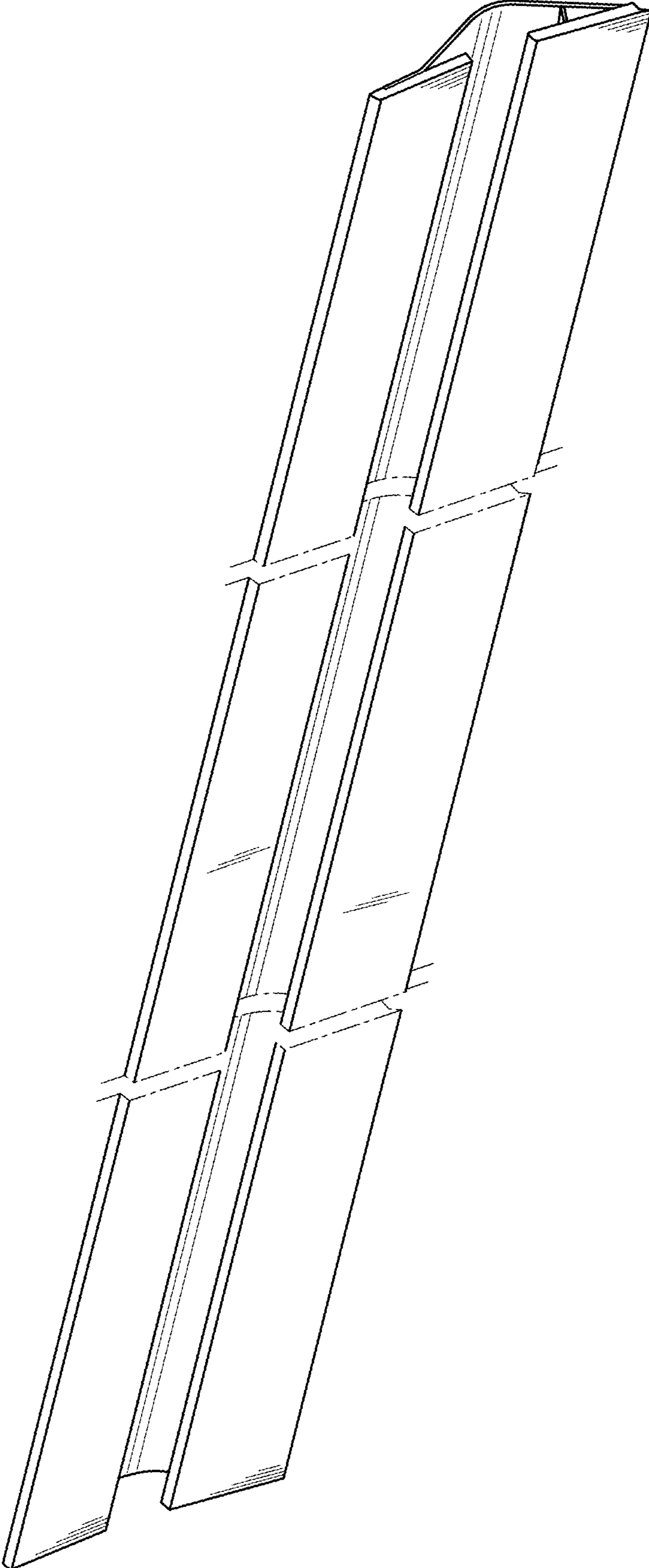

FIG. 3

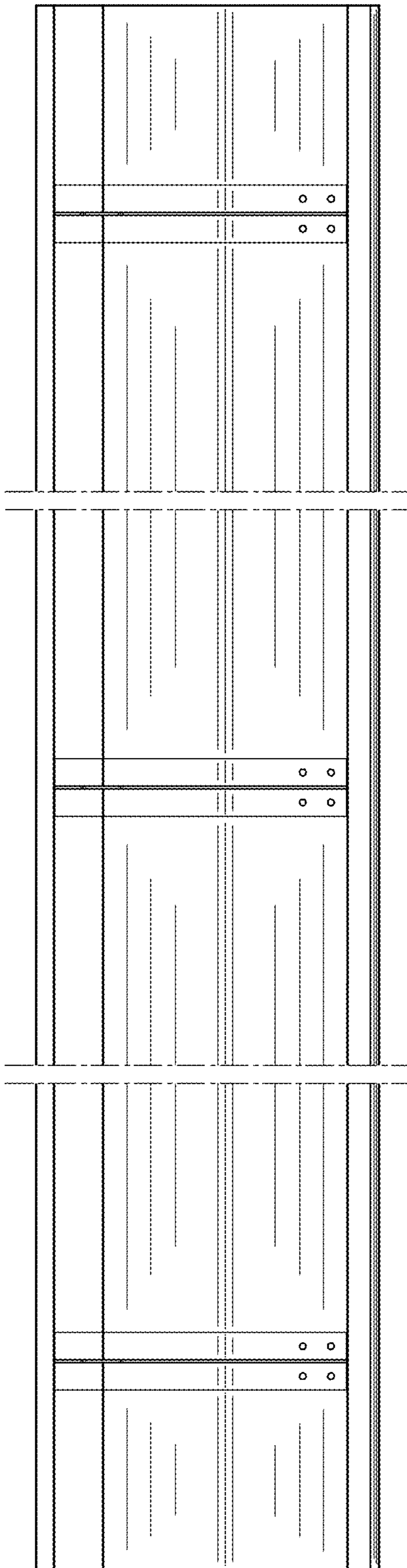

FIG. 4

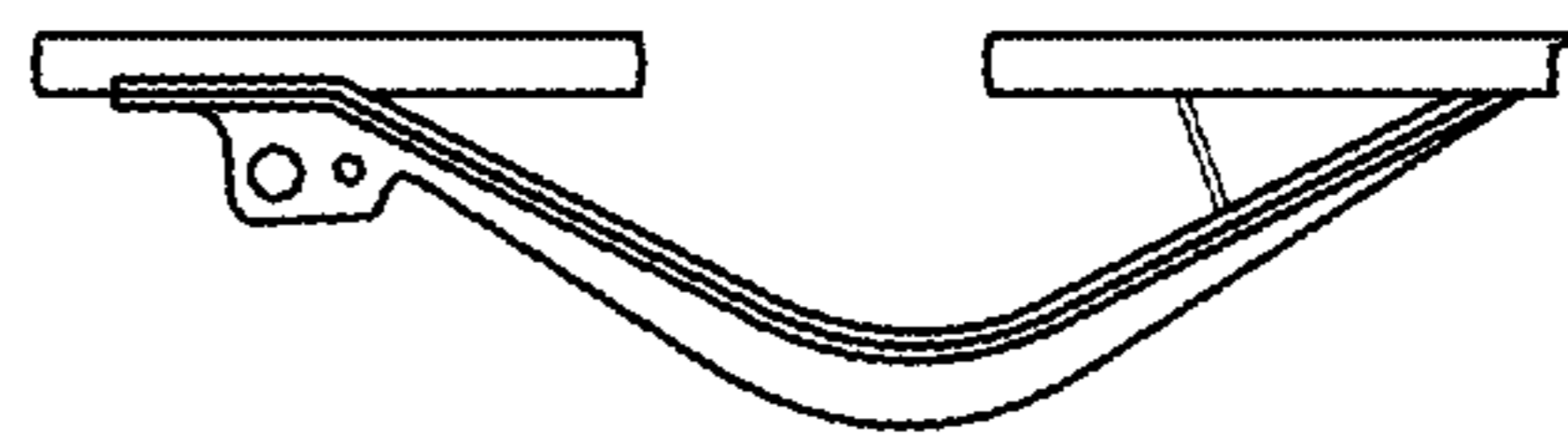

FIG. 5

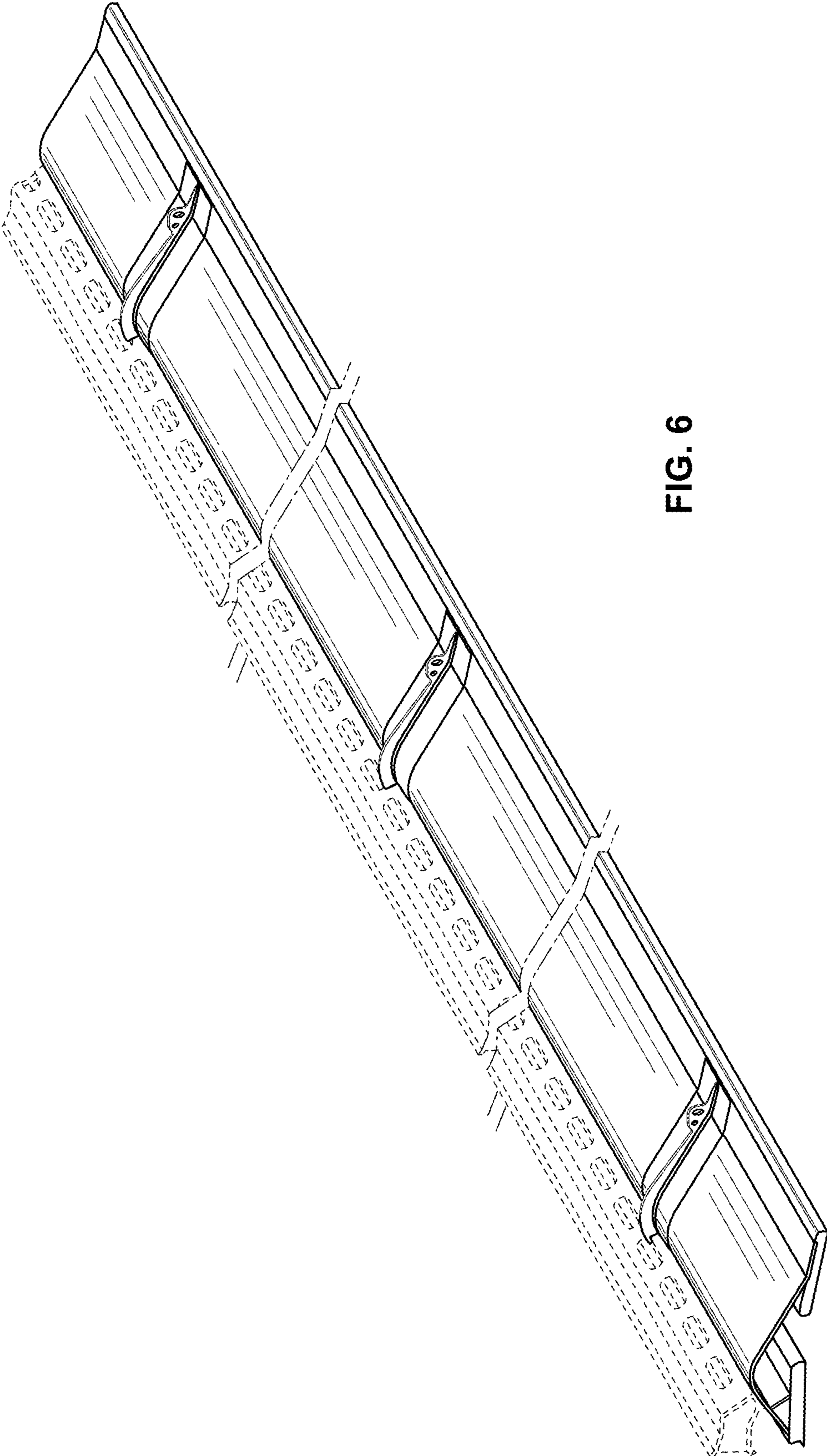

FIG. 6

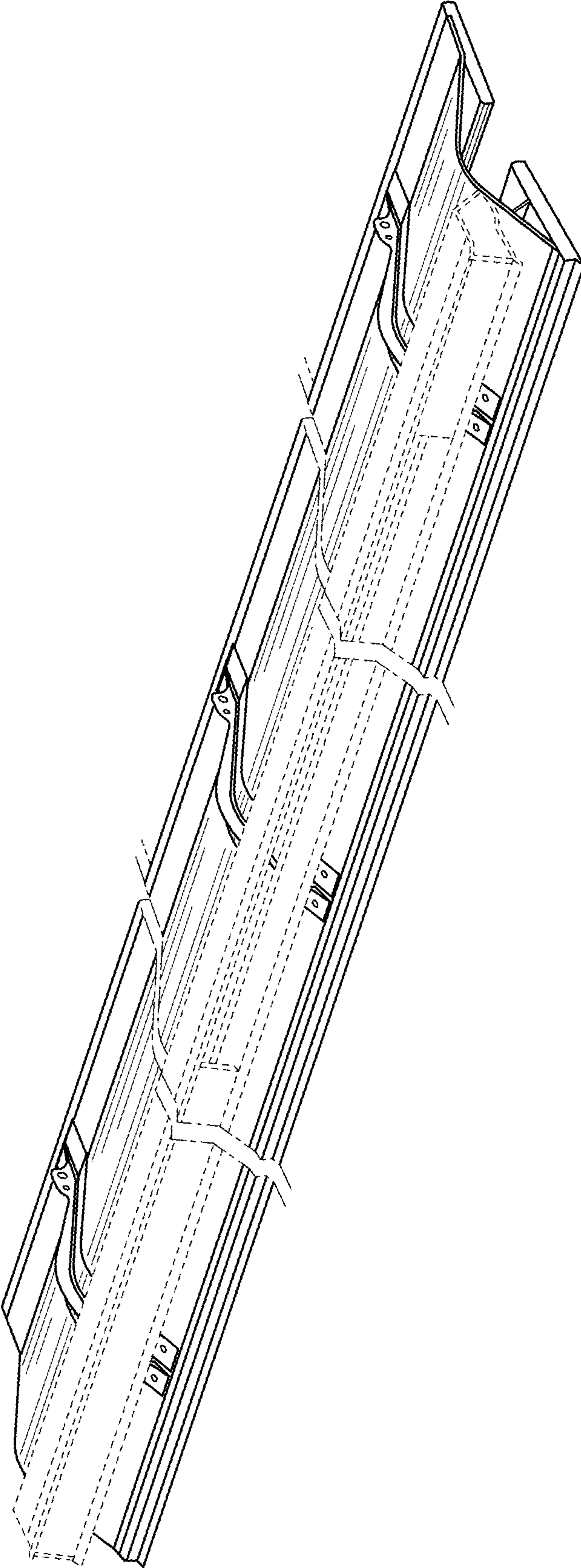

FIG. 7



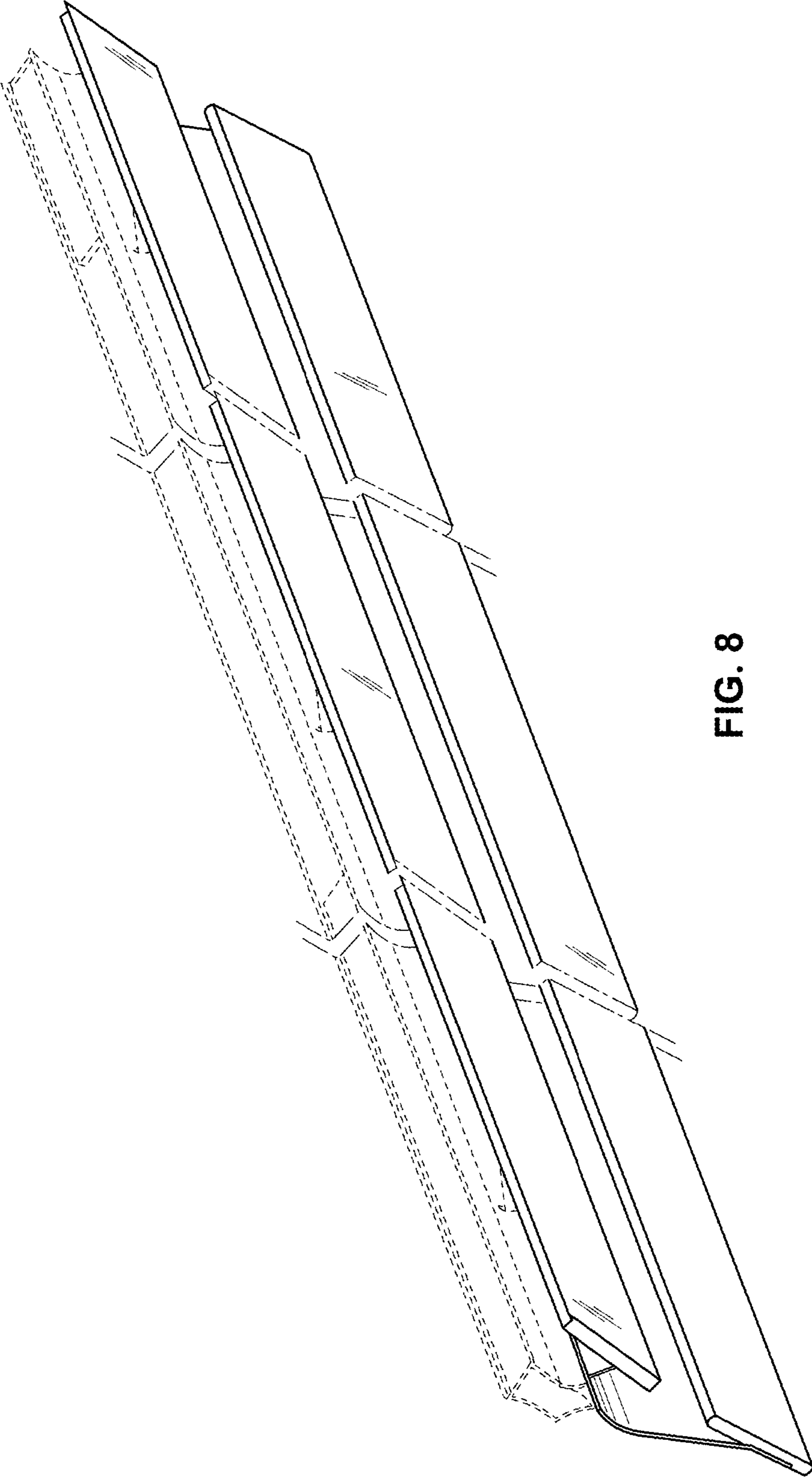

FIG. 8

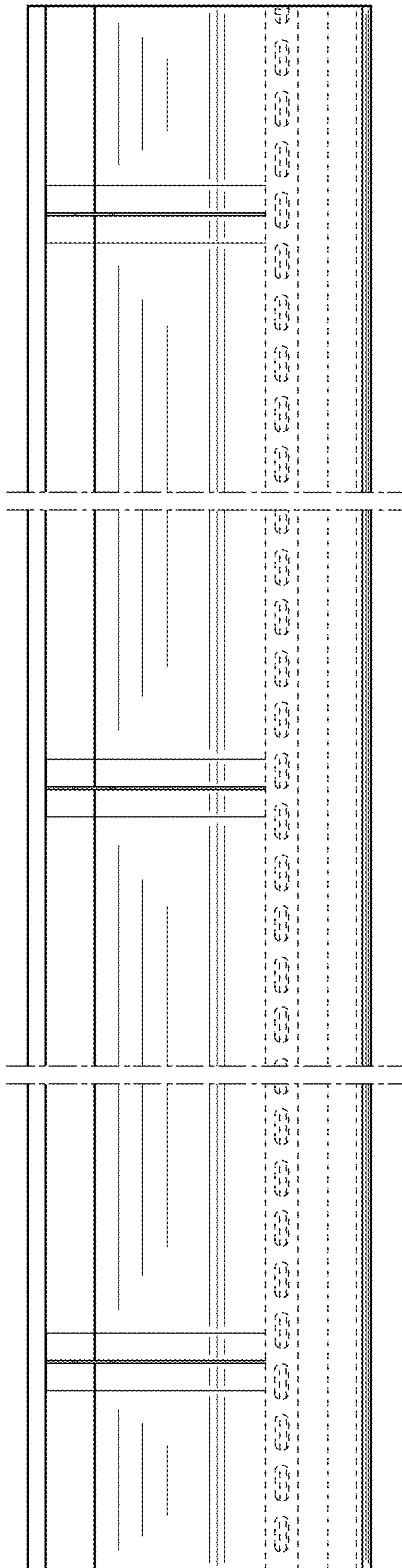

FIG. 9

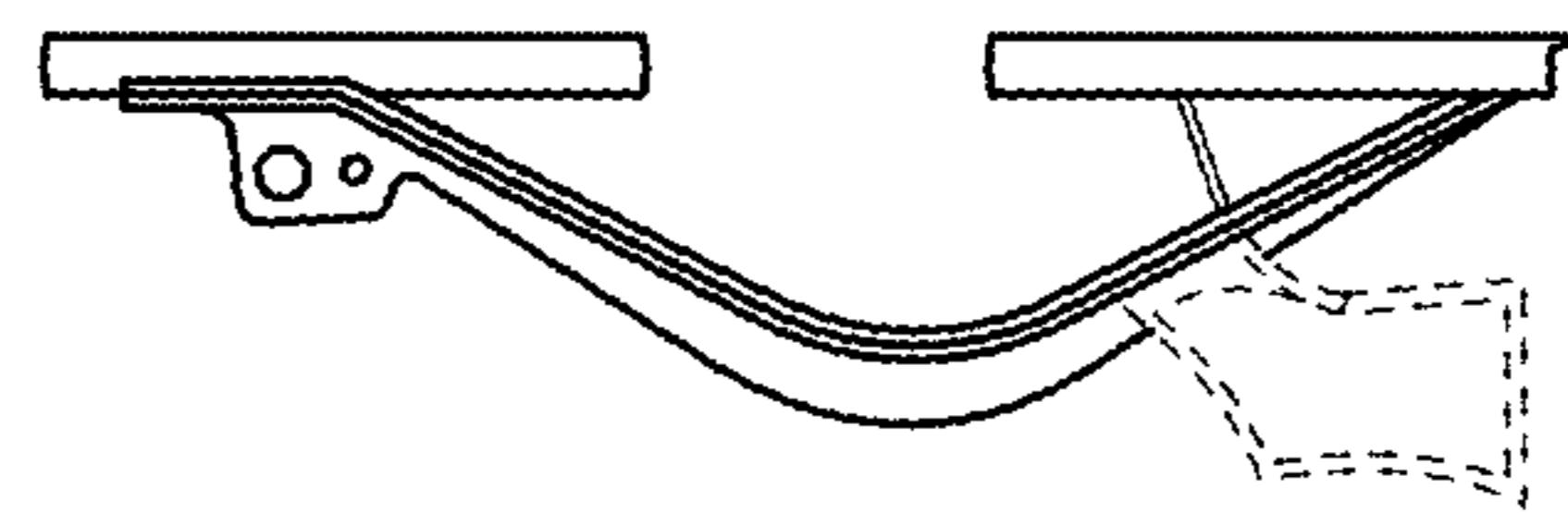

FIG. 10