



US00D770348S

(12) **United States Design Patent** (10) **Patent No.:** **US D770,348 S**
Shimizu et al. (45) **Date of Patent:** **** Nov. 1, 2016**

(54) **INSTRUMENT PANEL FOR AUTOMOBILE**

(71) Applicant: **Honda Motor Co., Ltd.**, Tokyo (JP)

(72) Inventors: **Yosuke Shimizu**, Wako (JP); **Yuta Nakai**, Wako (JP)

(73) Assignee: **Honda Motor Co., Ltd.**, Tokyo (JP)

(**) Term: **14 Years**

(21) Appl. No.: **29/521,063**

(22) Filed: **Mar. 19, 2015**

(30) **Foreign Application Priority Data**

Sep. 24, 2014 (JP) 2014-021118

(51) **LOC (10) Cl.** **12-16**

(52) **U.S. Cl.**
USPC **D12/192**

(58) **Field of Classification Search**
USPC D12/192, 415-426.1
CPC F16M 11/12; F16M 11/10
See application file for complete search history.

(56) **References Cited**

U.S. PATENT DOCUMENTS

D470,809 S * 2/2003 Asahi D12/192
D489,660 S * 5/2004 Okumura D12/192
D493,756 S * 8/2004 Yamamoto D12/192

D512,006 S * 11/2005 Sims D12/192
D515,487 S * 2/2006 Tanaka D12/192
D756,279 S * 5/2016 Shouno D12/192
2014/0077481 A1* 3/2014 Matsumoto B60R 21/2165
280/728.3
2015/0321560 A1* 11/2015 Webb B60K 37/00
296/70
2016/0129871 A1* 5/2016 Knauf B60K 35/00
280/730.1

* cited by examiner

Primary Examiner — Katrina A Betton

(74) *Attorney, Agent, or Firm* — Plumsea Law Group, LLC

(57) **CLAIM**

The ornamental design for an instrument panel for automobile, as shown and described.

DESCRIPTION

FIG. 1 is a perspective view from the front left side of an instrument panel for automobile.

FIG. 2 is a perspective view from the front right side thereof.

FIG. 3 is a front elevation view thereof.

FIG. 4 is a top plan view thereof.

FIG. 5 is a right side elevation view thereof; and,

FIG. 6 is a left side elevation view thereof.

The broken lines shown in the drawings illustrate portions of the instrument panel for automobile that form no part of claimed design.

1 Claim, 6 Drawing Sheets

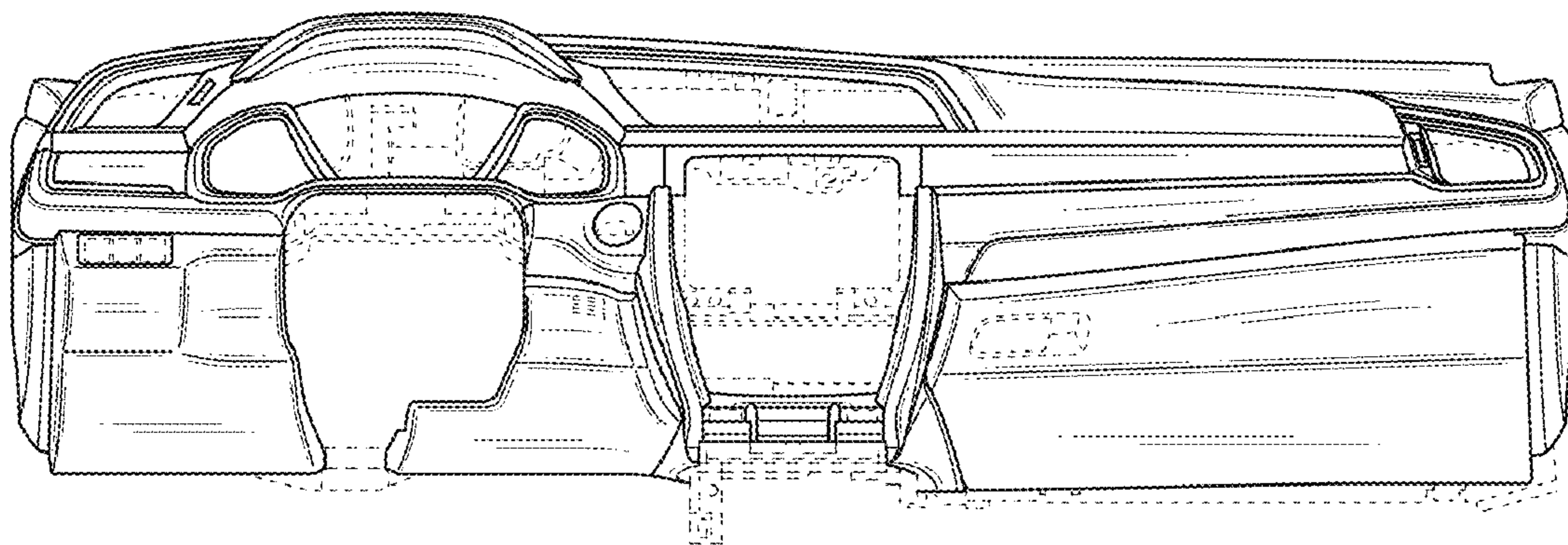

FIG. 1

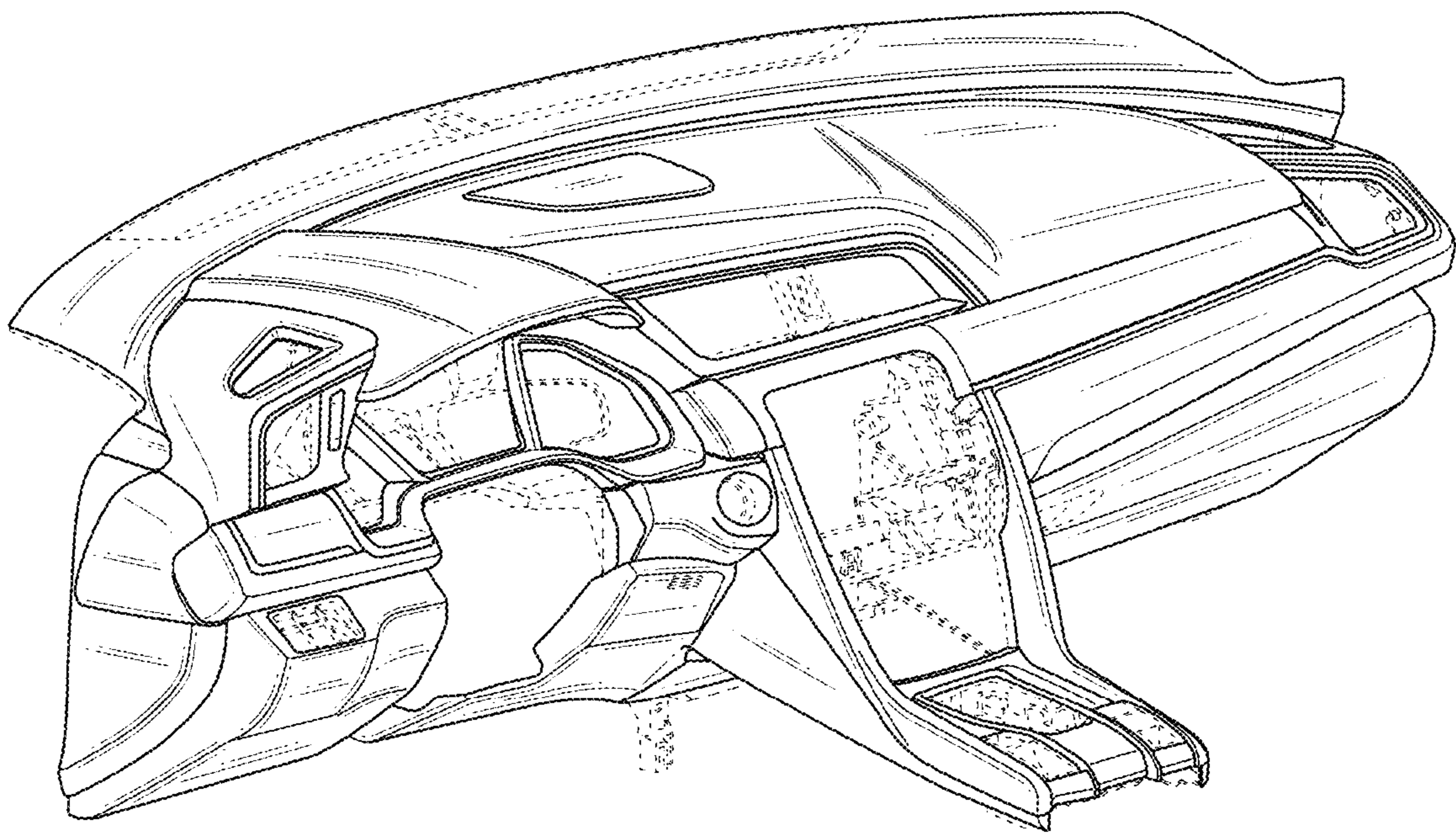

FIG. 2

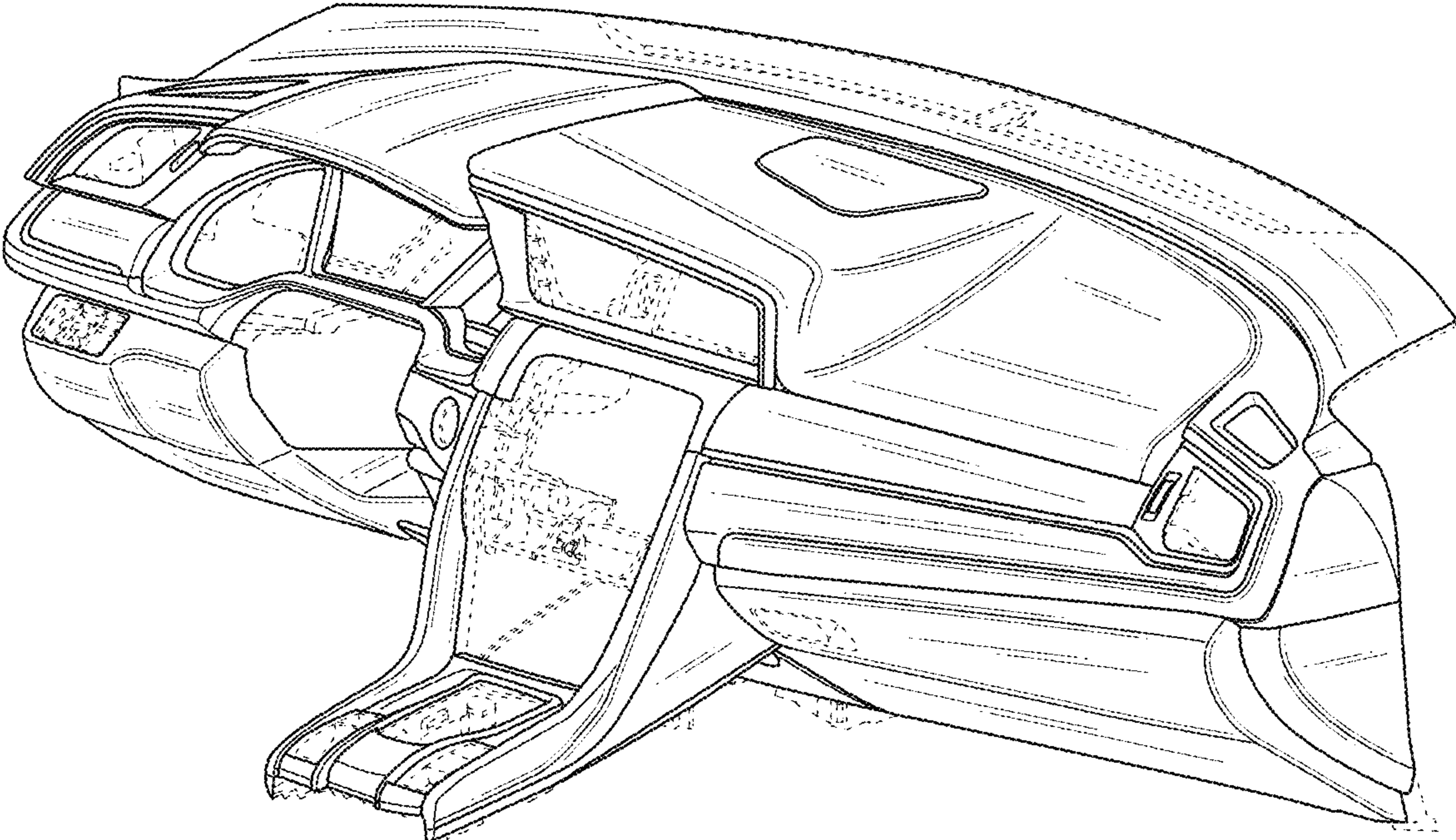

FIG. 3

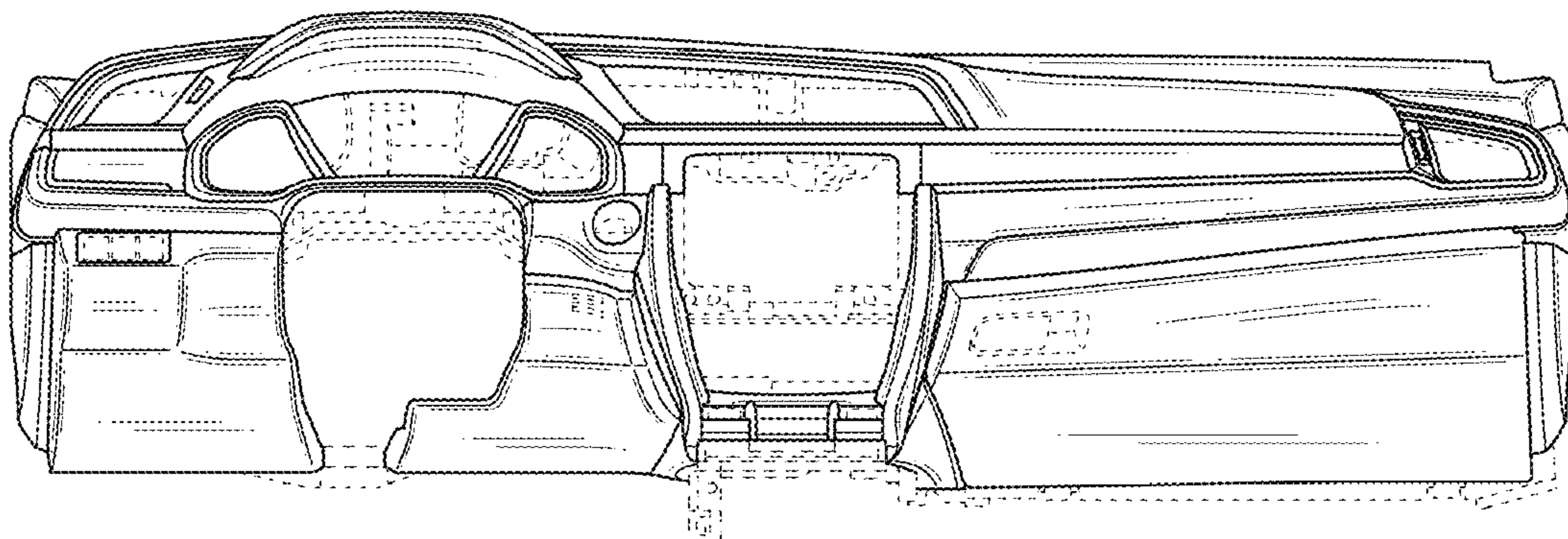

FIG. 4

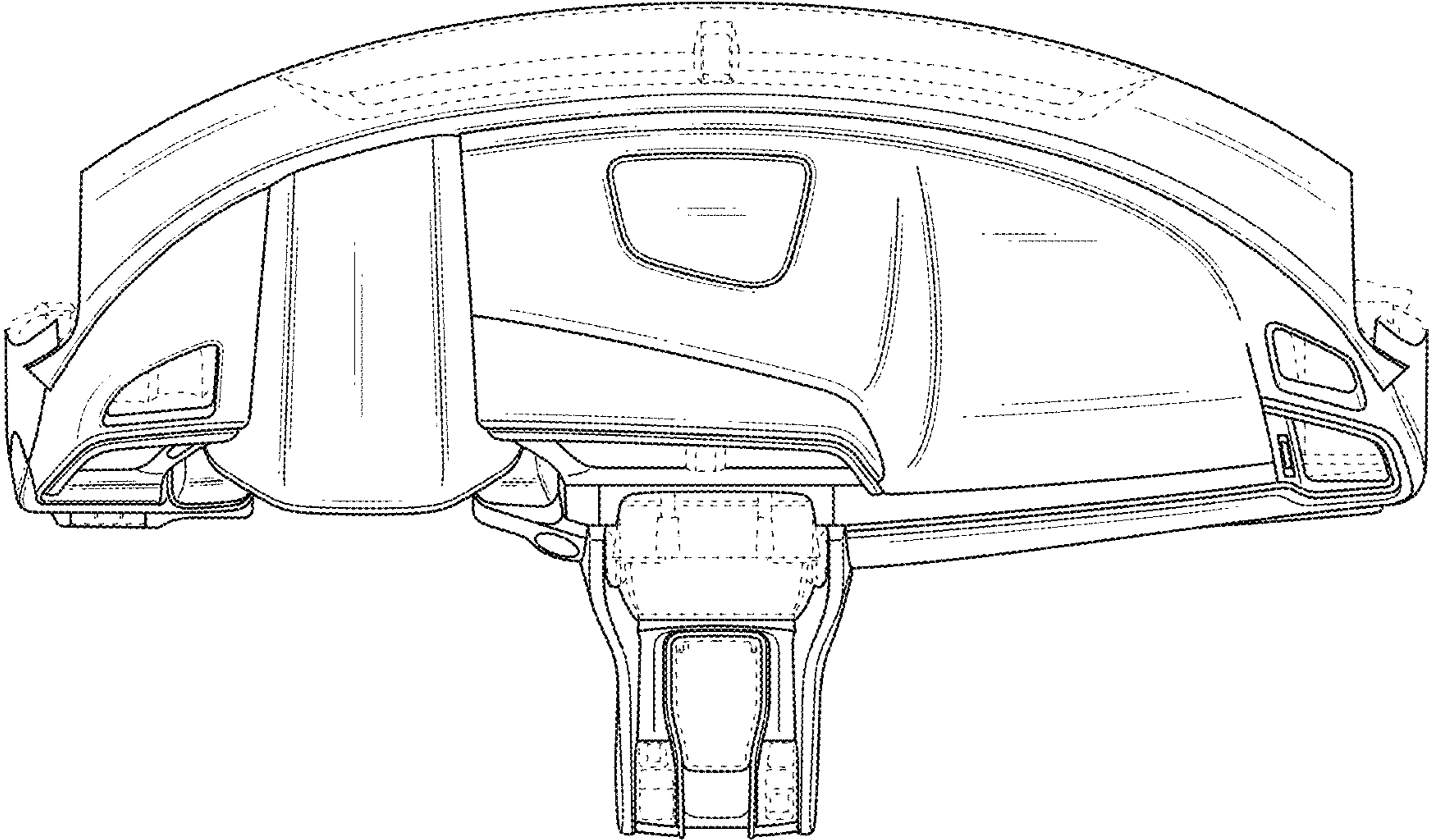

FIG. 5

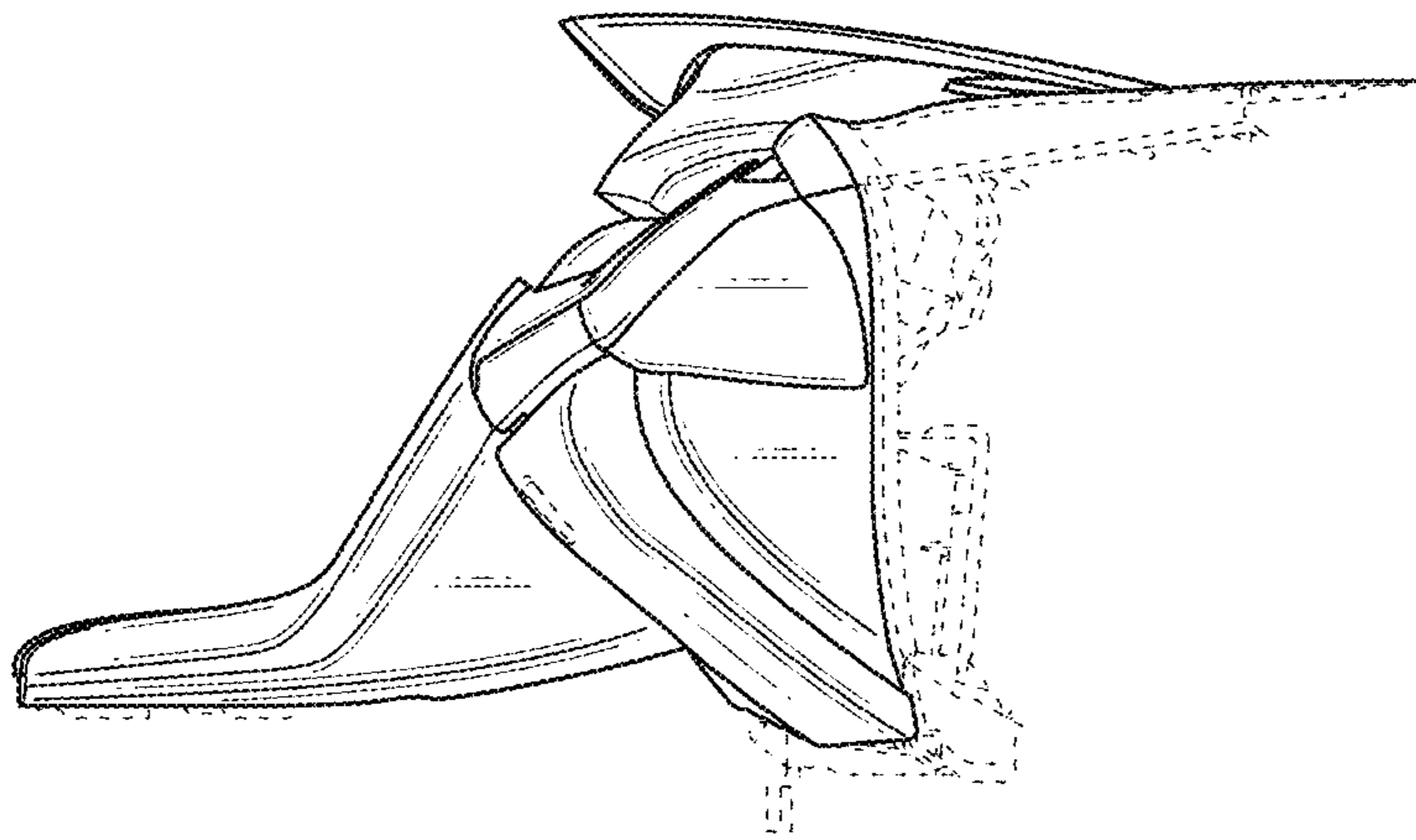

FIG. 6

