



US00D770069S

(12) **United States Design Patent** (10) **Patent No.:** **US D770,069 S**  
**Goltche** (45) **Date of Patent:** **\*\* Oct. 25, 2016**

(54) **SURFACE MOUNTING LIGHT FOR A VEHICLE**

(71) Applicant: **Yehuda Goltche**, Great Neck, NY (US)

(72) Inventor: **Yehuda Goltche**, Great Neck, NY (US)

(\*\*) Term: **15 Years**

(21) Appl. No.: **29/539,643**

(22) Filed: **Sep. 16, 2015**

(51) **LOC (10) Cl.** ..... **26-06**

(52) **U.S. Cl.**  
USPC ..... **D26/28**

(58) **Field of Classification Search**

USPC ..... D26/28-36; 362/61, 80-83, 267-269,  
362/459-468, 475-478, 485-487

CPC ..... F21S 48/00; F21S 48/10; F21S 48/115;  
F21S 48/225; F21S 48/1233; F21S 48/1266;  
F21S 48/1388; F21S 48/2268; F21V 5/00

See application file for complete search history.

(56) **References Cited**

**U.S. PATENT DOCUMENTS**

D507,670 S *	7/2005	Huang	.....	D26/28
D561,360 S *	2/2008	Wang	.....	D26/28
D564,108 S *	3/2008	Lassen	.....	D26/28
D578,684 S *	10/2008	Marquardt	.....	D26/28
D722,187 S *	2/2015	Gerardo	.....	D26/28
D733,946 S *	7/2015	Chen	.....	D26/28

\* cited by examiner

*Primary Examiner* — Marcus Jackson

(74) *Attorney, Agent, or Firm* — Dunlap Bennett & Ludwig PLLC

(57) **CLAIM**

The ornamental design for a surface mounting light for a vehicle, as shown and described.

**DESCRIPTION**

FIG. 1 is an isometric view of a surface mounting light for a vehicle, shown in use;

FIG. 2 is an isometric view thereof;

FIG. 3 is a front elevation view thereof, the rear elevation view being a mirror image thereof;

FIG. 4 is a left side elevation view thereof, the right side elevation view being a mirror image thereof;

FIG. 5 is a top plan view thereof; and,

FIG. 6 is a bottom plan view thereof.

The broken lines shown in the drawings illustrate portions of the surface mounting light for a vehicle that form no part of the claimed design.

The cutaway symbols illustrated in break lines in the drawings indicate a symbolic break in the length of the design for the surface mounting light for a vehicle indicating an indeterminate length. The appearance of any portion of the article between the break lines forms no part of the claimed design.

**1 Claim, 3 Drawing Sheets**

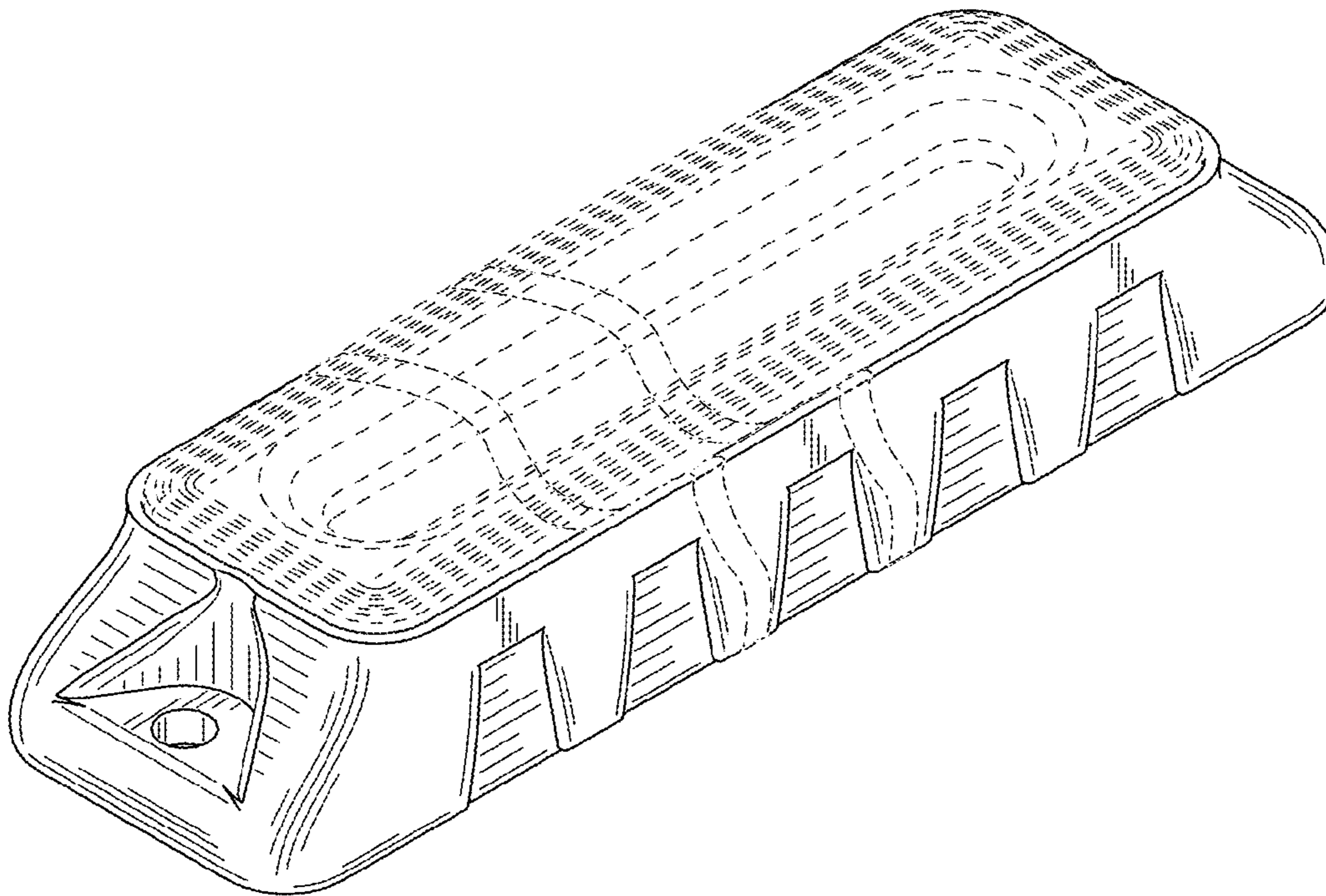

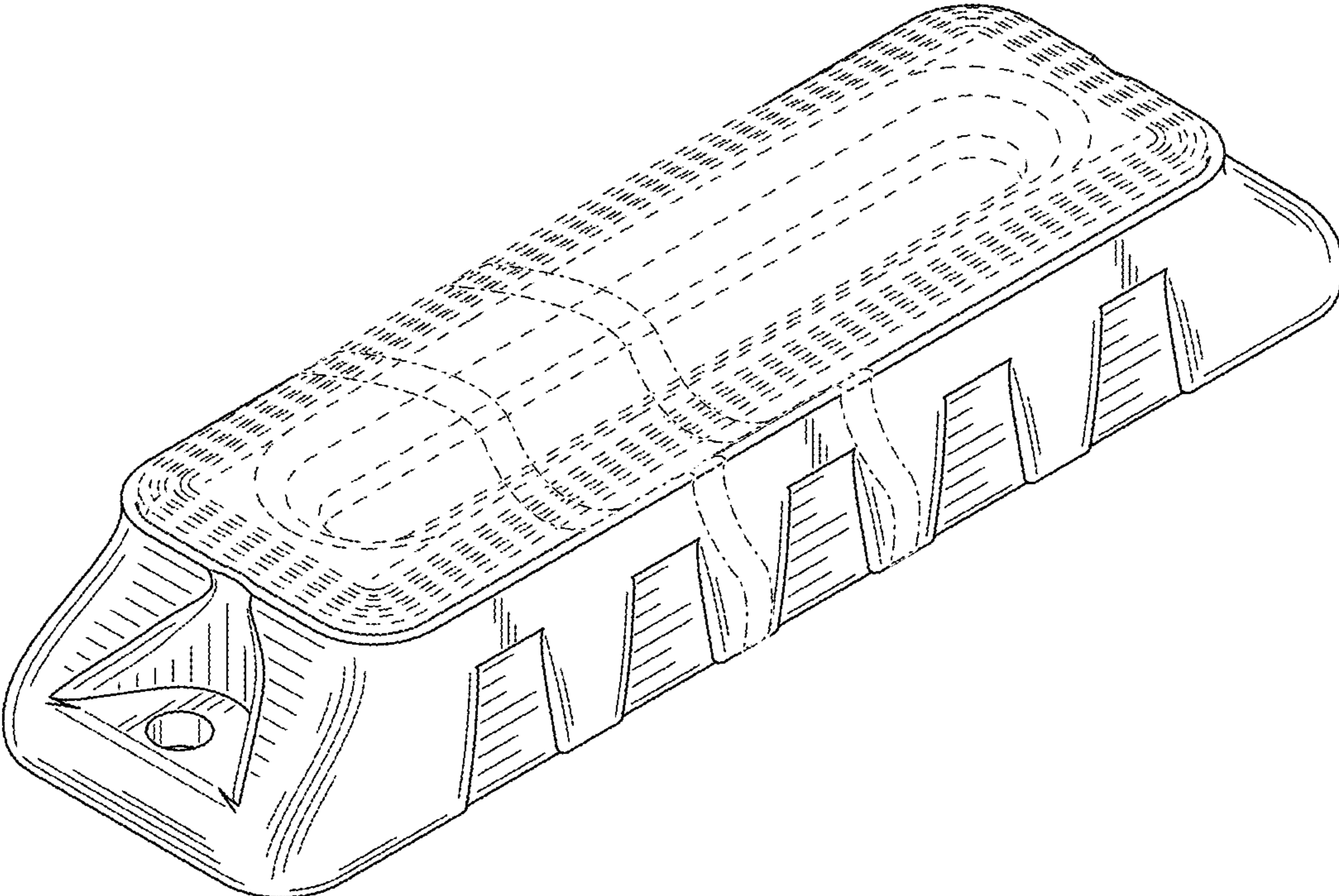

FIG. 1

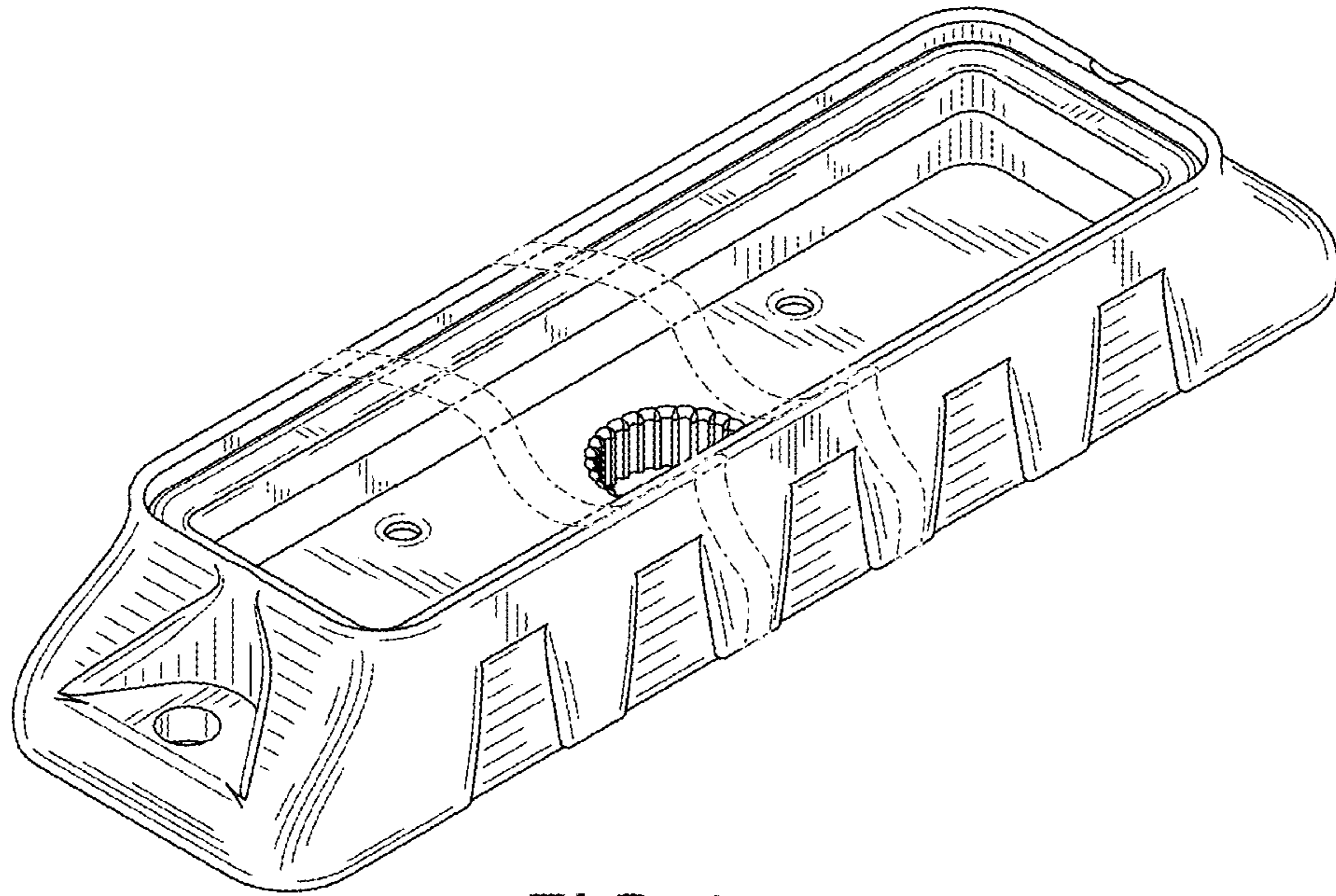

FIG. 2

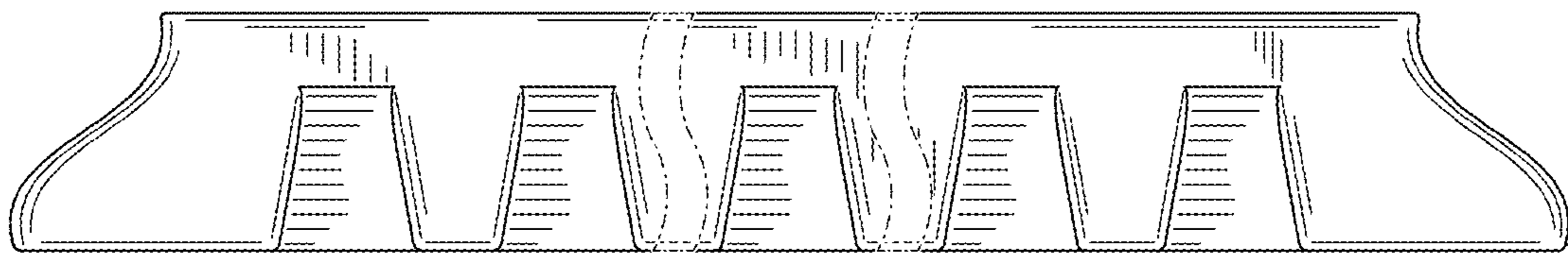

FIG. 3



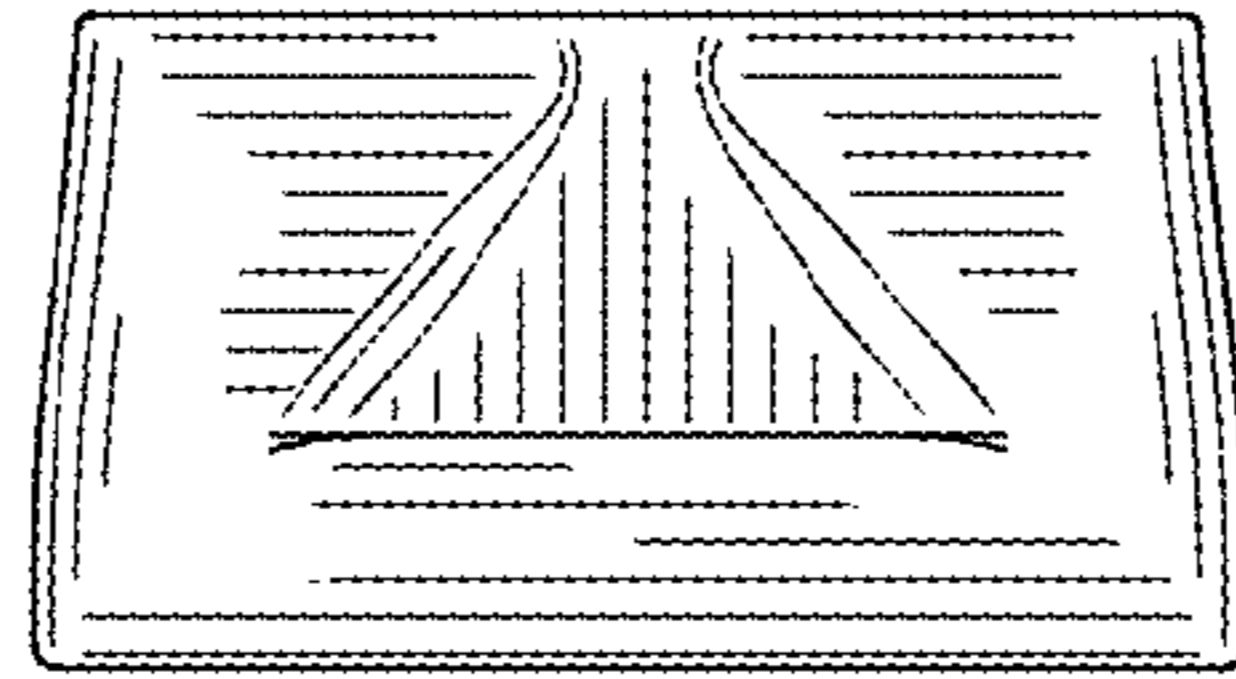

FIG. 4

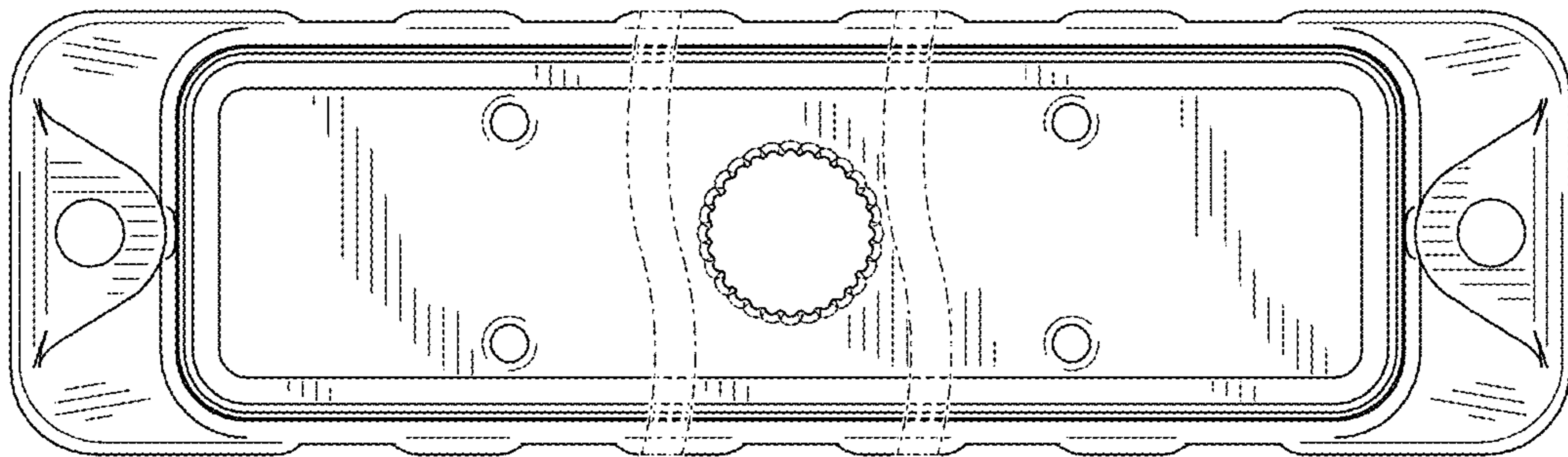

FIG. 5

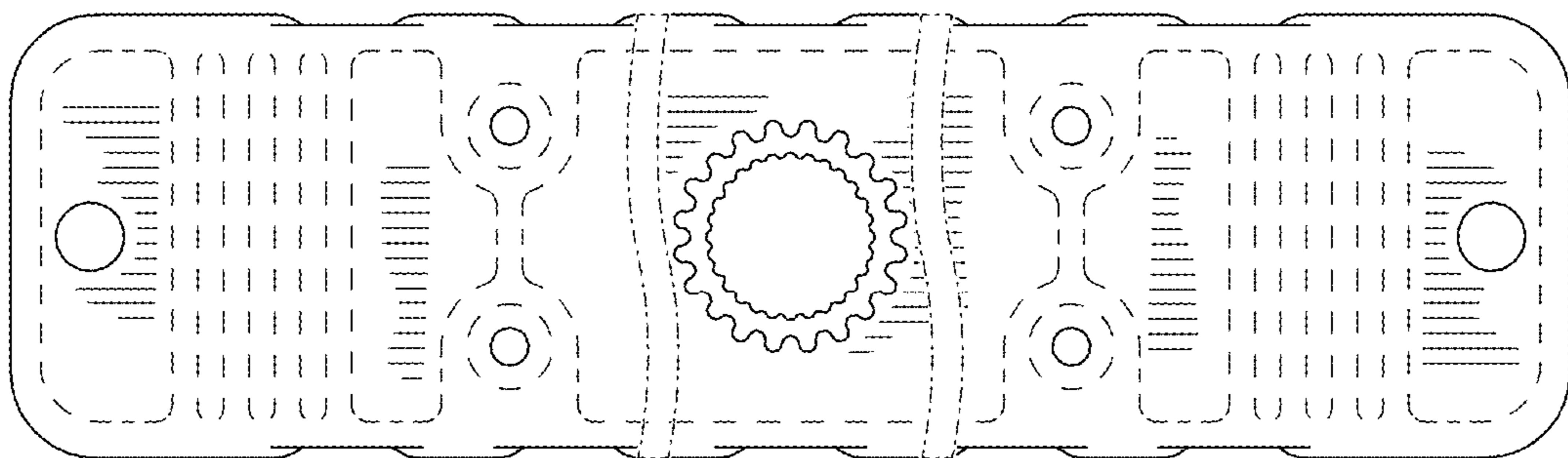

FIG. 6