



US00D770049S

(12) **United States Design Patent**
Yanagihara

(10) **Patent No.:** **US D770,049 S**
(45) **Date of Patent:** **** Oct. 25, 2016**

(54) **BED FOR MAGNETIC RESONANCE IMAGING APPARATUS**

(71) Applicant: **General Electric Company**,
Schenectady, NY (US)

(72) Inventor: **Koji Yanagihara**, Tokyo (JP)

(73) Assignee: **General Electric Company**,
Schenectady, NY (US)

(**) Term: **15 Years**

(21) Appl. No.: **29/534,419**

(22) Filed: **Jul. 28, 2015**

(30) **Foreign Application Priority Data**

Jan. 28, 2015 (JP) 2015-001515

(51) **LOC (10) Cl.** **24-01**

(52) **U.S. Cl.**
USPC **D24/159; D24/183**

(58) **Field of Classification Search**

USPC D24/158-161, 185, 186, 107, 183, 184
CPC .. A61B 6/035; A61B 6/4405; A61B 6/4411;
A61B 6/4429; A61B 6/4435; A61B 6/4441;
A61B 6/4447; A61B 6/484; A61B 6/0407;
A61B 6/0428; A61G 2210/50

See application file for complete search history.

(56) **References Cited**

U.S. PATENT DOCUMENTS

D681,208 S *	4/2013	Ninomiya	D24/159
D726,319 S *	4/2015	Sul	D24/159
D727,509 S *	4/2015	Tan	D24/159
D736,934 S *	8/2015	Kim	D24/183
D748,804 S *	2/2016	Eenboom	D24/183
D752,757 S *	3/2016	Li	D24/159
2009/0306494 A1 *	12/2009	Scarth	A61B 5/0035 600/411

* cited by examiner

Primary Examiner — Anhdao Doan

(74) *Attorney, Agent, or Firm* — Alleman Hall McCoy
Russell & Tuttle LLP

(57) **CLAIM**

The ornamental design for a bed for magnetic resonance imaging apparatus, as shown and described.

DESCRIPTION

FIG. 1 is a front perspective view of a design for a bed for magnetic resonance imaging apparatus in a raised position. The bed for magnetic resonance imaging apparatus includes a removable compartment on a rear portion of the bed surface, a sliding compartment on a front portion of the bed surface, a flip-up compartment on the front side of the bed and a drawer on each side of the bed.

FIG. 2 is a top view of the bed for magnetic resonance imaging apparatus of FIG. 1 with both the removable compartment and the sliding compartment in closed positions.

FIG. 3 is a left side view of the bed for magnetic resonance imaging apparatus of FIG. 1.

FIG. 4 is a right side view of the bed for magnetic resonance imaging apparatus of FIG. 1.

FIG. 5 is a front view of the bed for magnetic resonance imaging apparatus of FIG. 1 with the flip-up compartment in a closed position.

FIG. 6 is a back view of the bed for magnetic resonance imaging apparatus of FIG. 1.

FIG. 7 is bottom view of the bed for magnetic resonance imaging apparatus of FIG. 1.

FIG. 8 is a front perspective view of the bed for magnetic resonance imaging apparatus of FIG. 1 in a lowered position. The removable compartment, sliding compartment and flip-up compartment are in closed positions.

FIG. 9 is a top view of the bed for magnetic resonance imaging apparatus of FIG. 1 with the removable compartment in an open position where a cover has been removed, and where the sliding compartment is in an open position.

FIG. 10 is an enlarged partial top view of the bed for magnetic resonance imaging apparatus of FIG. 9 with the sliding compartment in an open position; and,

FIG. 11 is an enlarged perspective view of the front portion of the bed for magnetic resonance imaging apparatus of FIG. 1 with the flip-up compartment in an open position where the cover extending over the front side of the bed has been flipped up to the top surface. The top surface of the bed for magnetic resonance imaging apparatus has been slid forward exposing a lower opening.

The broken lines illustrate portions of the bed that form no part of the claimed design. The wavy break line shown in FIGS. 10 and 11 indicate the point at which the enlarged view is cut off.

1 Claim, 9 Drawing Sheets

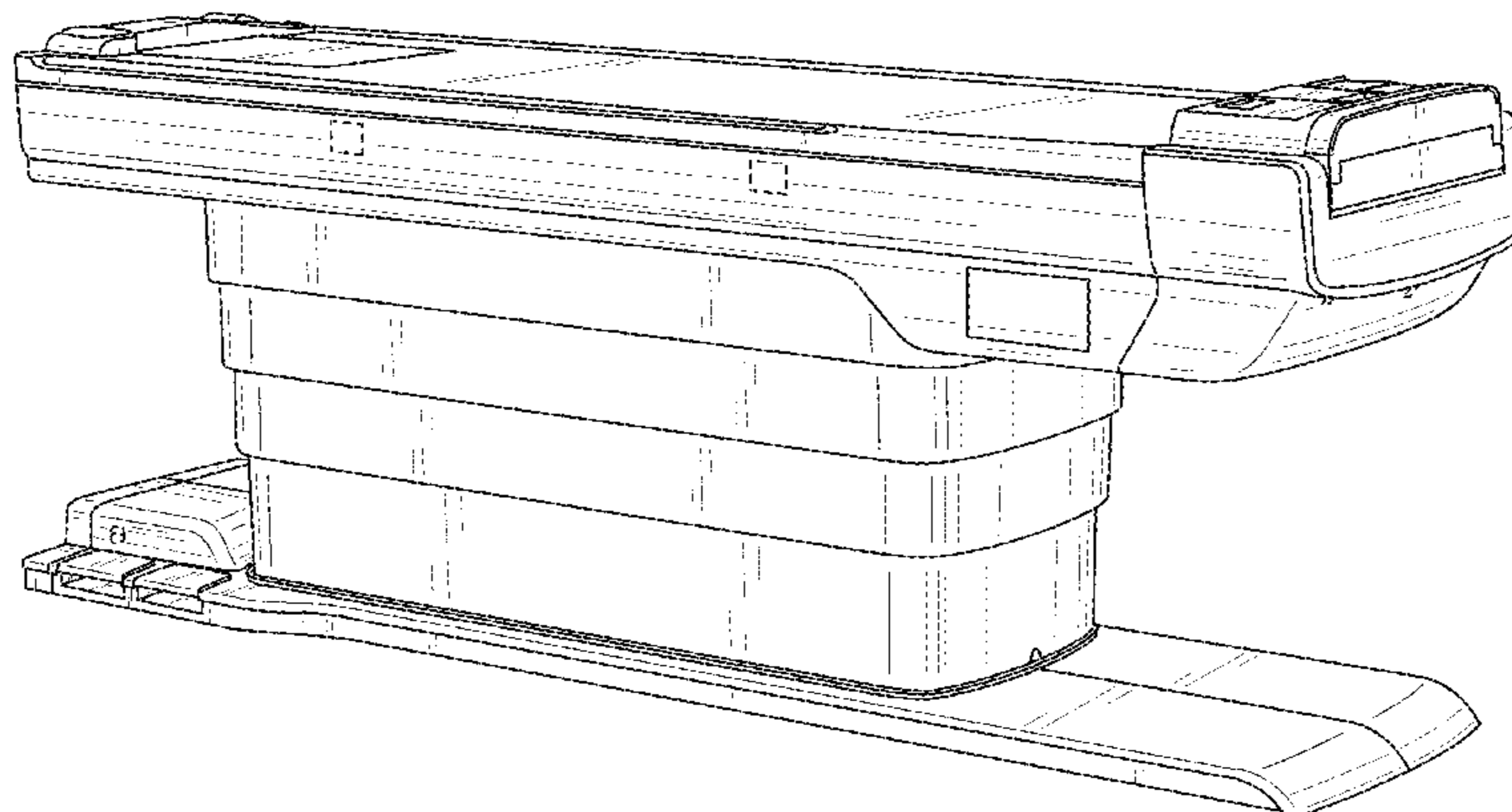

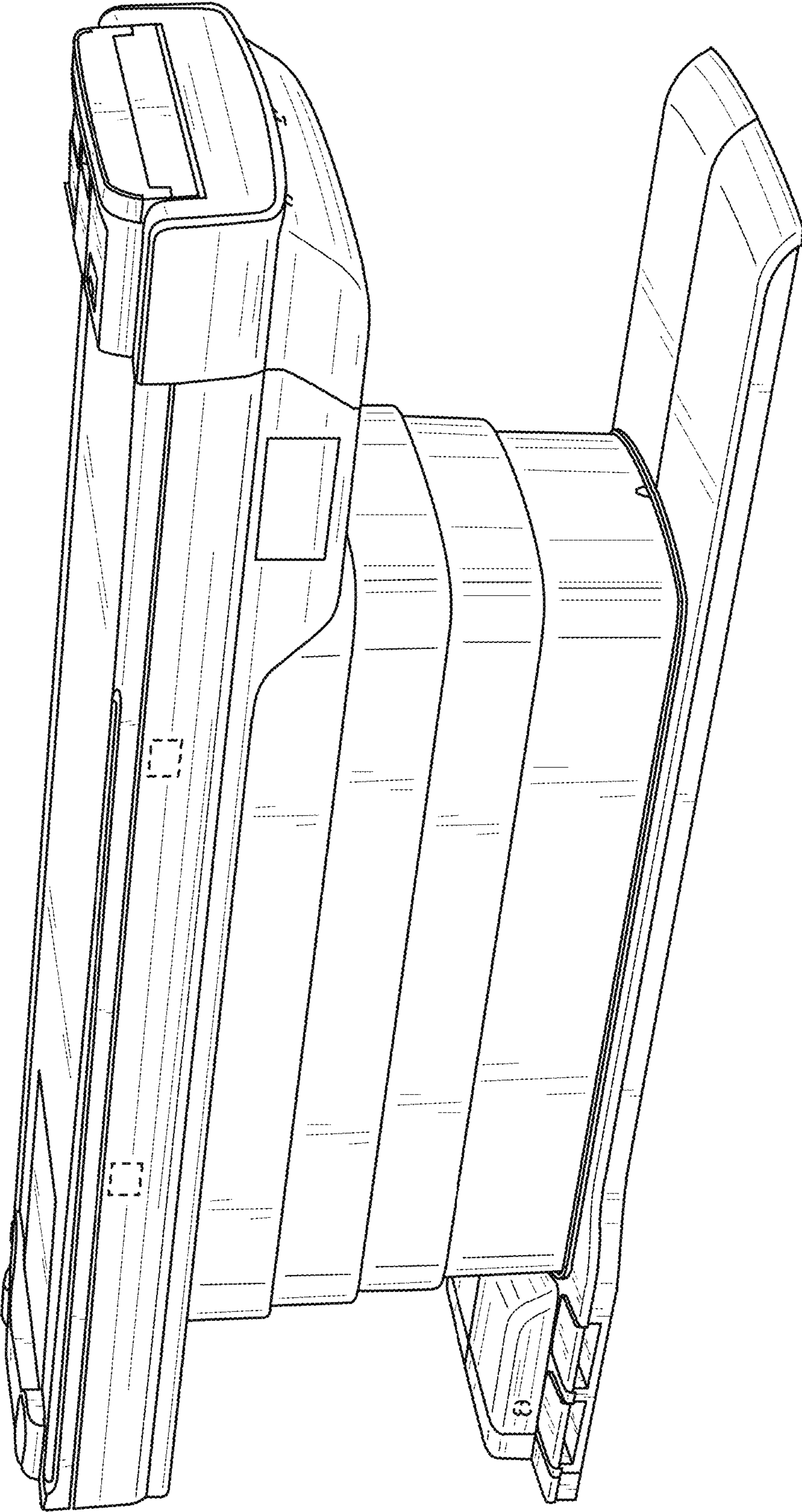

FIG. 1

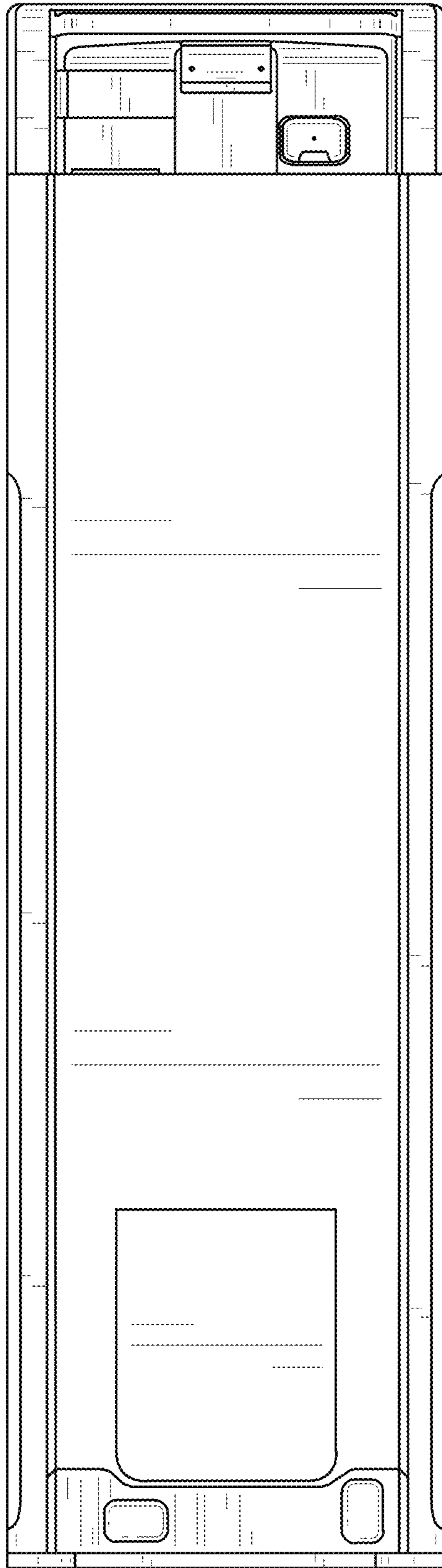

FIG. 2

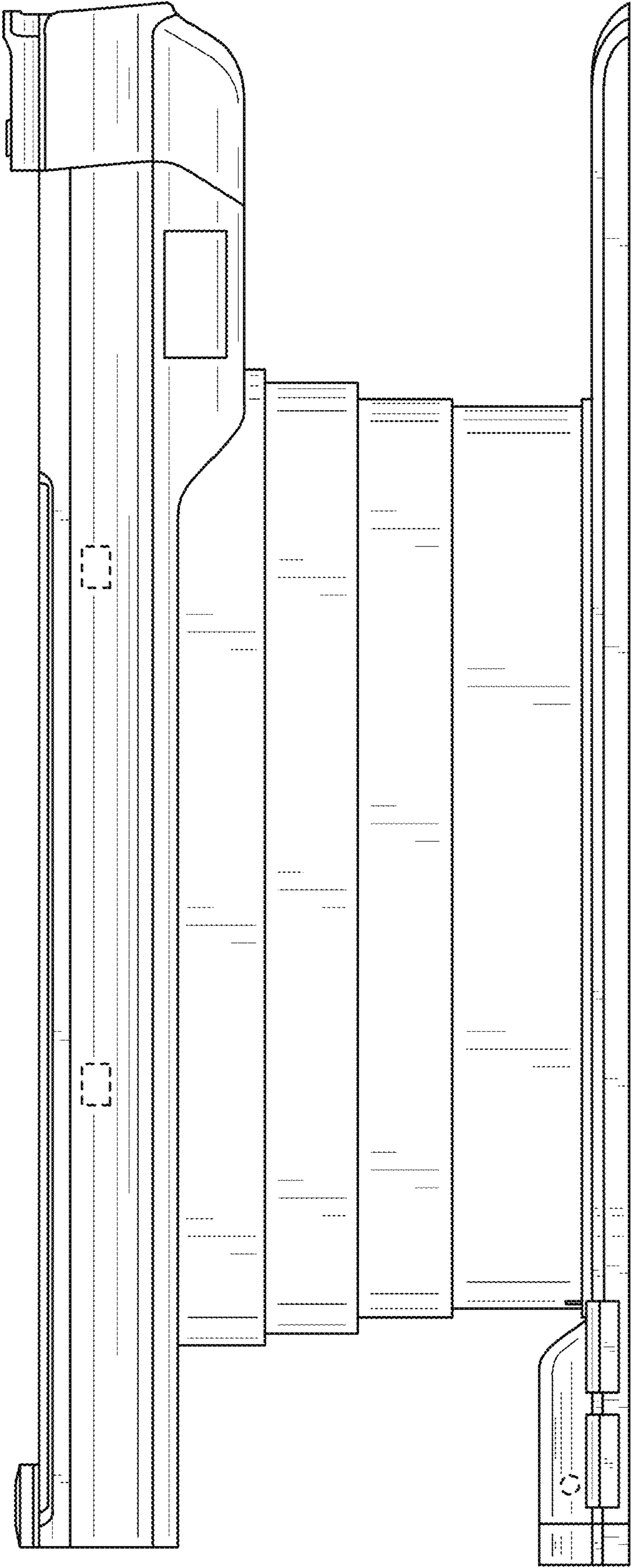

FIG. 3

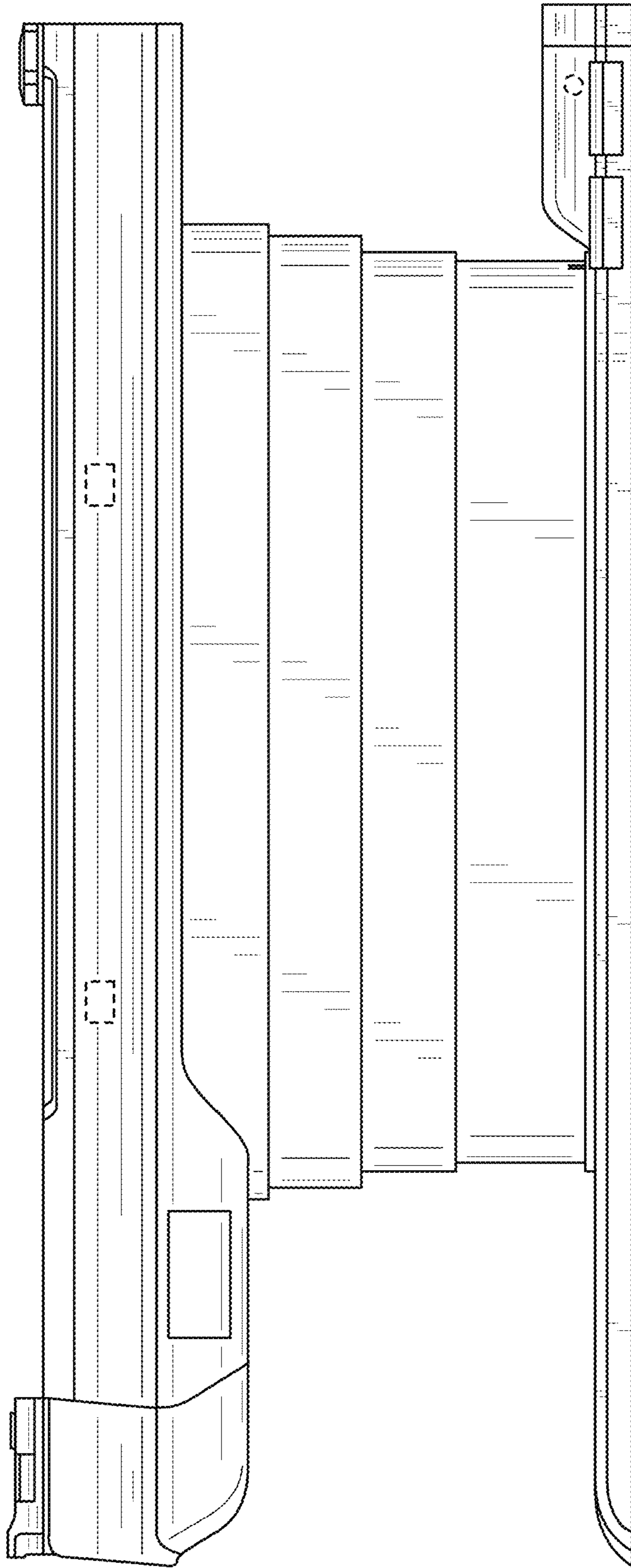

FIG. 4

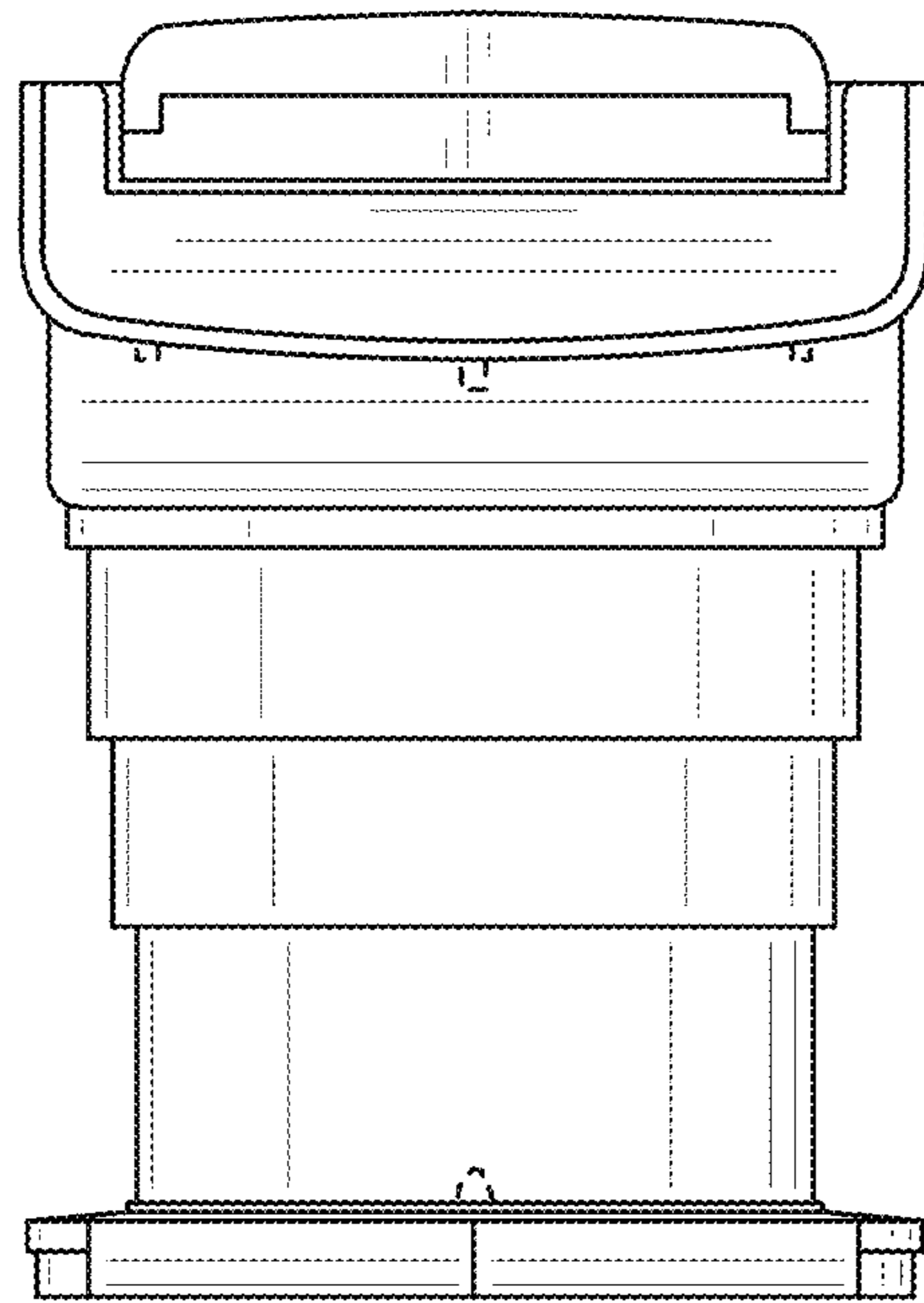

FIG. 5

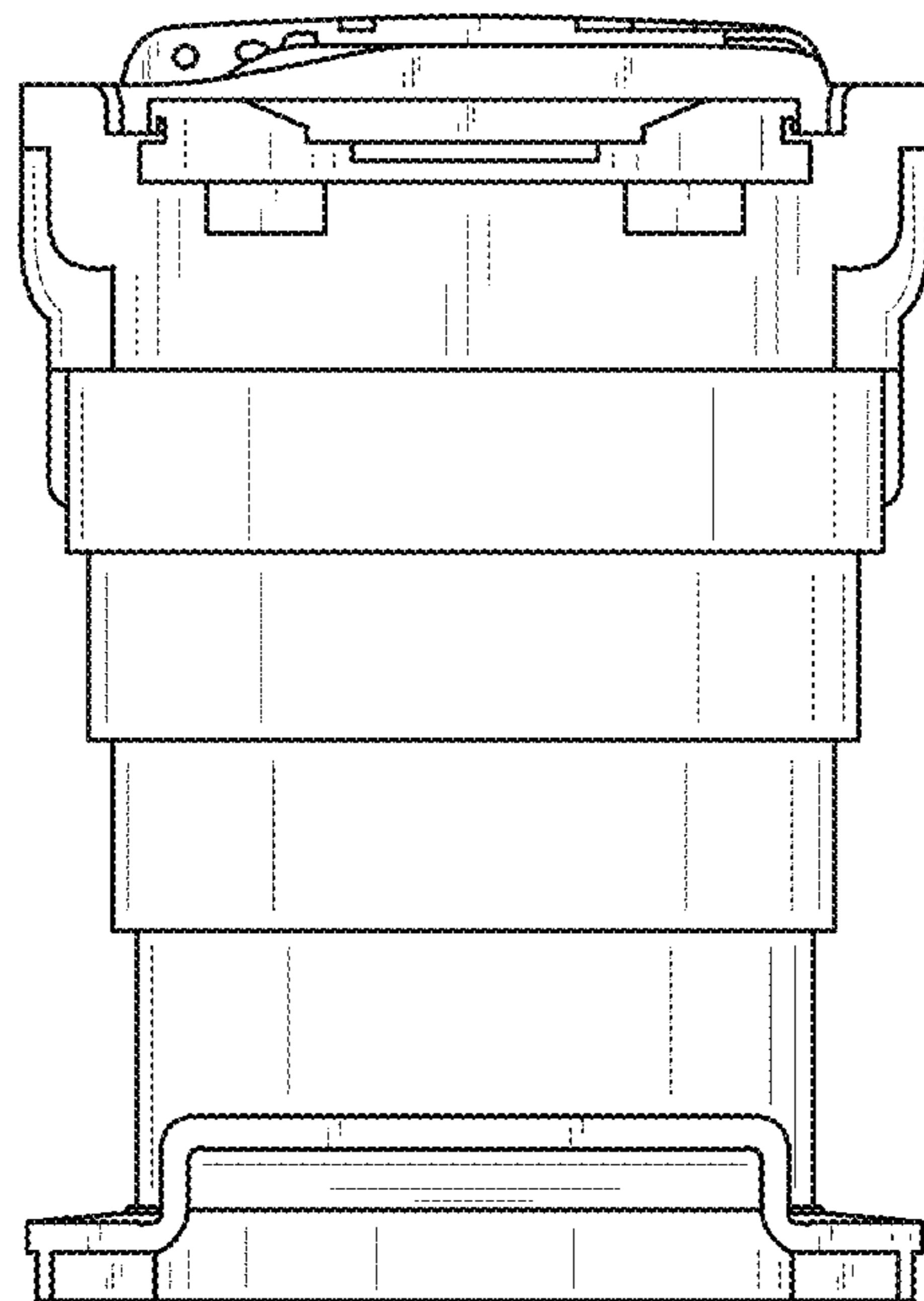

FIG. 6

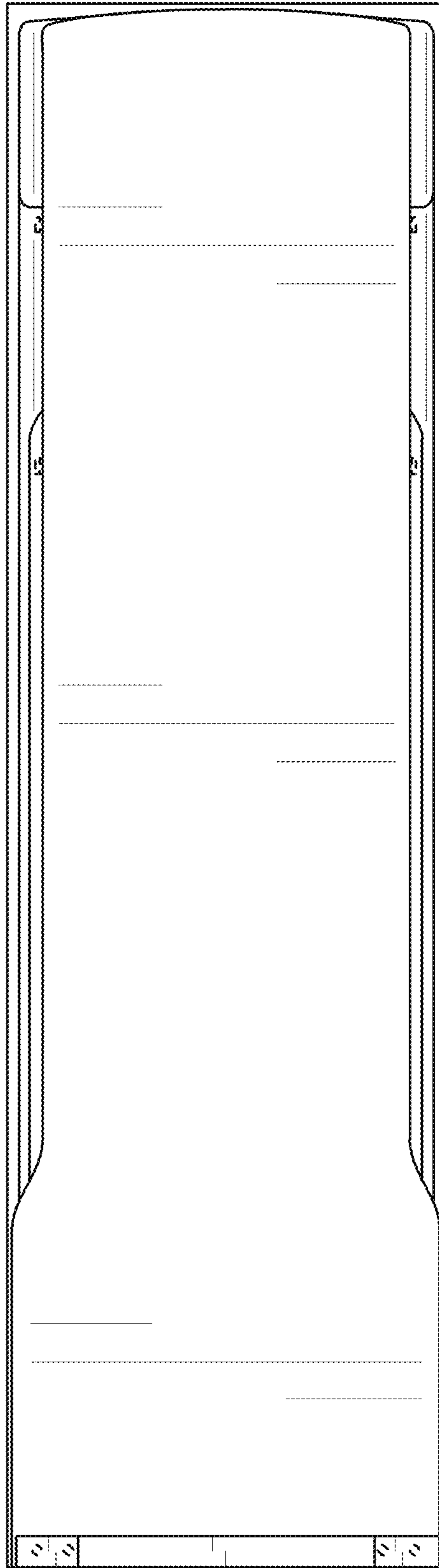

FIG. 7

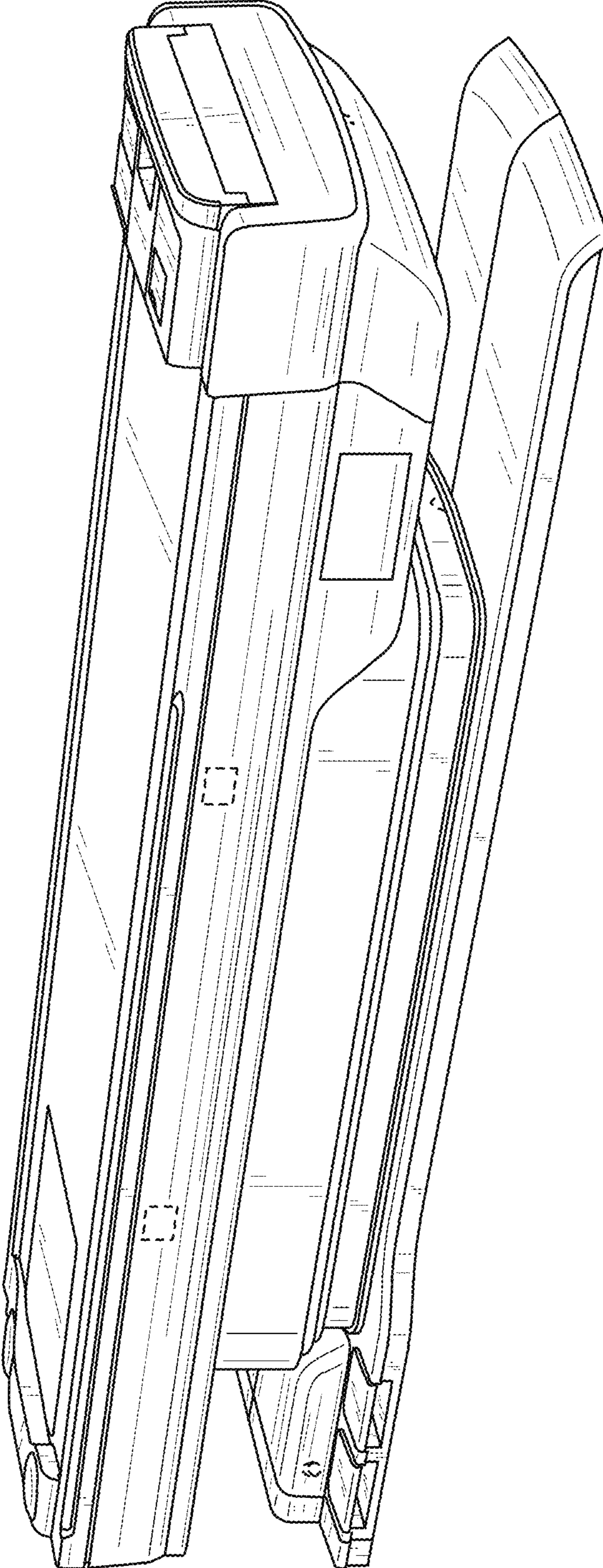

FIG. 8

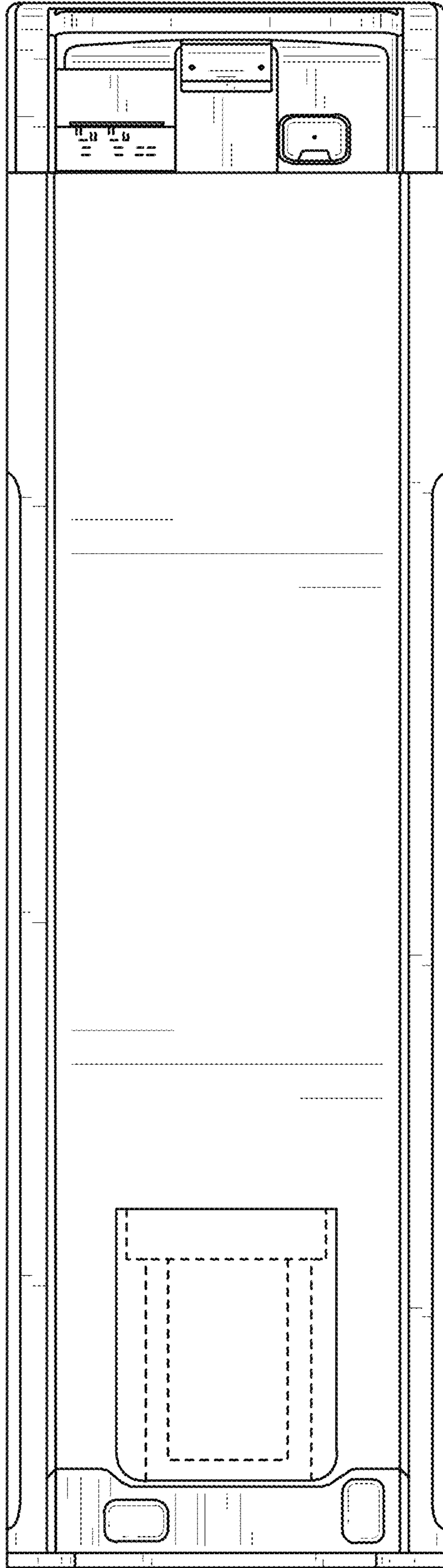

FIG. 9

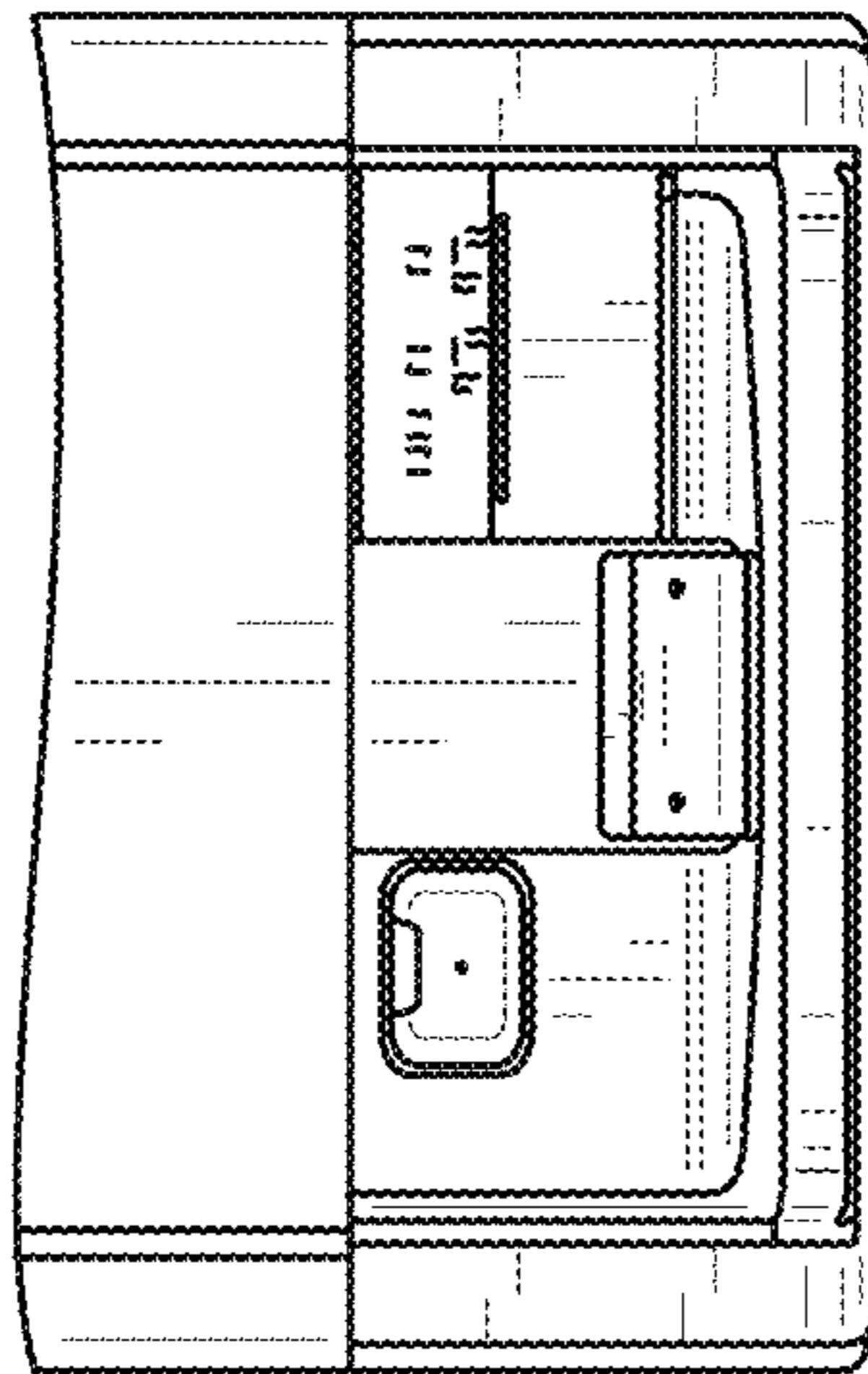

FIG. 10

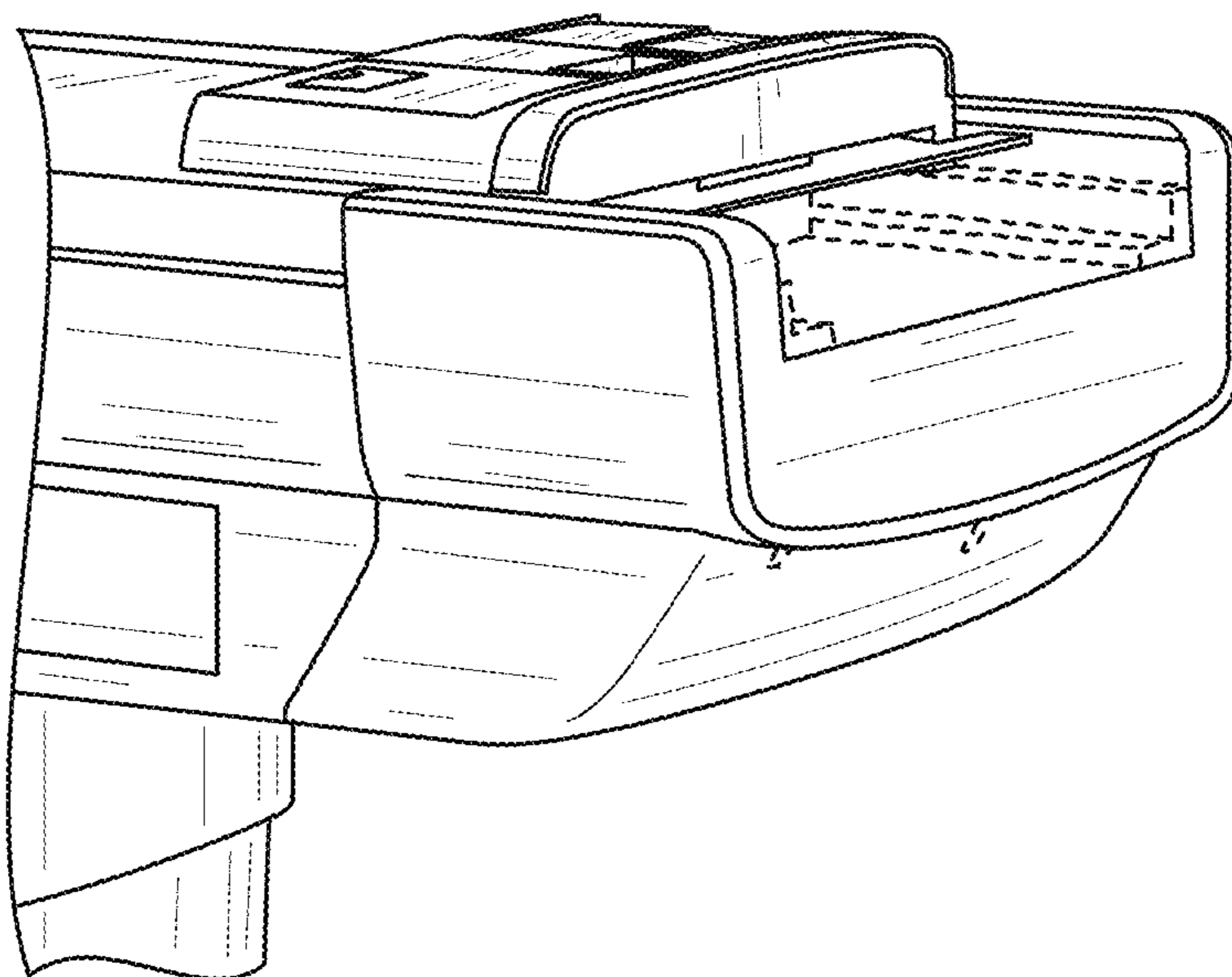

FIG. 11