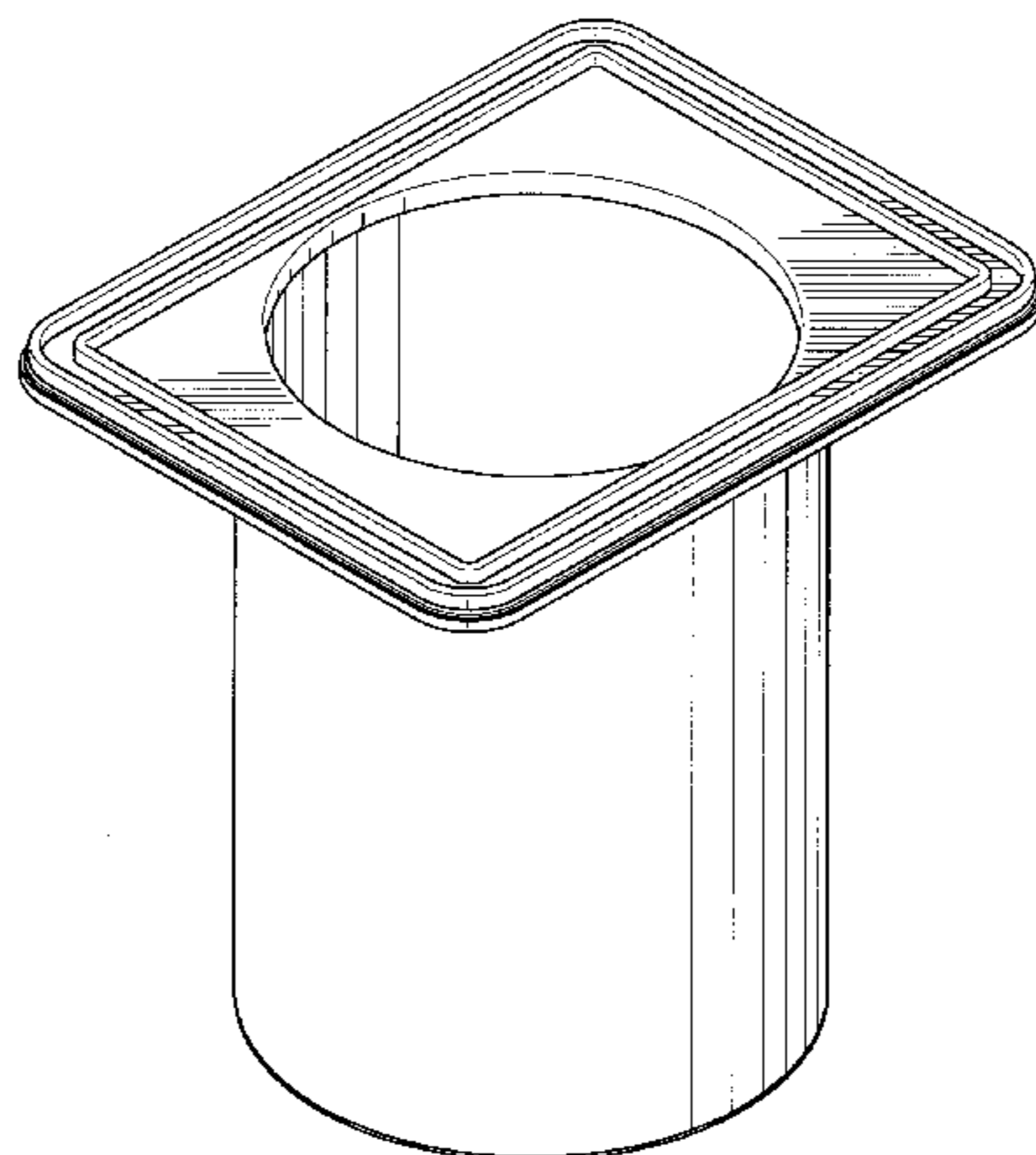




US00D770026S

(12) **United States Design Patent** (10) **Patent No.:** **US D770,026 S**  
**Morgan et al.** (45) **Date of Patent:** **\*\* Oct. 25, 2016**

(54) <b>FILTER</b>	3,912,473 A *	10/1975	Wilkins .....	B01D 46/10 126/299 D
(71) Applicant: <b>CAMFIL USA, INC.</b> , Riverdale, NJ (US)	3,951,626 A *	4/1976	Carey .....	B01D 46/0005 55/480
(72) Inventors: <b>Lee Pendleton Morgan</b> , Jonesboro, AR (US); <b>Tim Hudson</b> , Jonesboro, AR (US)	4,088,463 A 4,138,234 A 4,187,091 A 4,213,771 A 4,322,231 A 4,704,144 A	5/1978 2/1979 2/1980 7/1980 3/1982 11/1987	Smith Kubesa Durre et al. Guibet Hilzendeger et al. LeBlanc et al.	
(73) Assignee: <b>CAMFIL USA, INC.</b> , Riverdale, NJ (US)	D294,167 S * 4,725,292 A *	2/1988 2/1988	Meissner .....	D23/209 B01D 29/007 55/290
(**) Term: <b>15 Years</b>	4,738,697 A 4,746,339 A 4,900,342 A *	4/1988 5/1988 2/1990	Westergren Millard Spengler .....	B01D 46/10 415/119
(21) Appl. No.: <b>29/558,399</b>	5,013,333 A	5/1991	Beaufoy et al.	
(22) Filed: <b>Mar. 17, 2016</b>	5,156,660 A 5,290,441 A D353,649 S 5,688,298 A D390,910 S * 5,746,792 A 5,746,796 A D398,046 S * 5,803,954 A D403,418 S * 5,855,634 A *	10/1992 3/1994 12/1994 11/1997 2/1998 5/1998 5/1998 9/1998 9/1998 12/1998 1/1999	Wilson Griffin et al. Willinger et al. Bosses Sundquist .....	D23/209 D23/365
<b>Related U.S. Application Data</b>				
(63) Continuation of application No. 14/874,050, filed on Oct. 2, 2015, which is a continuation of application No. 14/187,258, filed on Feb. 22, 2014, now Pat. No. 9,174,155, which is a continuation of application No. 13/275,832, filed on Oct. 18, 2011, now Pat. No. 8,673,037.				
(51) <b>LOC (10) Cl.</b> .....	<b>28-99</b>			
(52) <b>U.S. Cl.</b> USPC .....	<b>D23/365</b>			
(58) <b>Field of Classification Search</b> USPC .....	D23/355-365, 386-388, 314, 325, 302, D23/283, 493, 502; 55/478, 482, 483, 490, 55/497, 498, 520, 521, 529, 508, 511; 95/273, 278, 279, 280			
CPC ..	B01D 46/00; B01D 46/0004; B01D 27/04; B01D 27/06; B01D 39/00			
See application file for complete search history.				
(56) <b>References Cited</b>				
U.S. PATENT DOCUMENTS				
2,352,503 A	6/1944	Walton		
3,334,752 A	8/1967	Matravers et al.		
3,508,383 A *	4/1970	Buonpastore .....	B01D 46/2411 210/304	
3,680,286 A	8/1972	Nostrand et al.		
	D476,725 S *	7/2003	Dushek .....	D23/365
	6,613,115 B2	9/2003	Moore	
	6,660,053 B2 *	12/2003	Oh .....	A47L 9/1666 55/337
	6,676,721 B1	1/2004	Gillingham et al.	



6,757,933	B2 *	7/2004	Oh	.....	A47L 9/1691 15/347
6,808,547	B2	10/2004	Ota et al.		
7,135,051	B2 *	11/2006	Baldinger	.....	A47L 5/24 15/347
D535,373	S	1/2007	Chung		
7,186,333	B2	3/2007	Kluge		
D545,955	S *	7/2007	Arias	.....	D23/365
7,247,183	B2	7/2007	Connor et al.		
7,323,029	B2	1/2008	Engelland et al.		
7,332,005	B2	2/2008	Wegelin		
7,341,613	B2	3/2008	Kirsch		
7,374,595	B2 *	5/2008	Gierer	.....	A47L 9/127 55/498
7,448,112	B2	11/2008	Li		
7,524,349	B2	4/2009	Schrage et al.		
7,662,200	B2	2/2010	Knuth et al.		
D621,915	S *	8/2010	Fima	.....	D23/261
D646,369	S	10/2011	Nelson et al.		
8,157,878	B2	4/2012	Weber et al.		
D690,408	S *	9/2013	Williams	.....	D23/365
D692,543	S	10/2013	Gorman et al.		
D694,871	S *	12/2013	Maholick	.....	D23/365
8,673,037	B2 *	3/2014	Morgan	.....	B01D 46/0005 55/341.1
D716,429	S *	10/2014	Carter	.....	D23/365
D716,430	S *	10/2014	Carter	.....	D23/365
D716,431	S *	10/2014	Carter	.....	D23/365
D717,420	S *	11/2014	Von Seggern	.....	D23/365
D717,933	S *	11/2014	McClelland	.....	D23/365
D739,513	S *	9/2015	Williams	.....	D23/365
9,174,155	B2	11/2015	Morgan et al.		
D751,185	S *	3/2016	Harris	.....	D23/386
D751,686	S *	3/2016	Harris	.....	D23/386
2002/0020160	A1	2/2002	Moore		
2005/0126137	A1	6/2005	Wang		
2007/0084170	A1	4/2007	Ehrenberg		
2007/0175191	A1 *	8/2007	Ziebold	.....	B01D 46/0031 55/482
2008/0092501	A1	4/2008	Sporre et al.		
2008/0127825	A1	6/2008	Raether		
2010/0037570	A1	2/2010	Osendorf et al.		
2010/0263344	A1	10/2010	Haynam et al.		
2011/0185689	A1	8/2011	Raether et al.		
2015/0314227	A1 *	11/2015	Williams	.....	B01D 46/0082 95/281
2016/0045848	A1 *	2/2016	Campbell	.....	B01D 46/525 55/357
2016/0059169	A1 *	3/2016	Cheng	.....	B01D 46/0004 55/482
2016/0059174	A1 *	3/2016	Hasenfratz	.....	B01D 46/2414 55/482

FOREIGN PATENT DOCUMENTS

CH	621712	A5	2/1981
DE	9405637	U1	5/1994
EP	1889648	A2	2/2008
EP	2918939	A1	9/2015
GB	1516721	A	7/1978
WO	WO-2009/061998	A1	5/2009
WO	2011/069508	A1	6/2011

OTHER PUBLICATIONS

HemiPleat.TM. Tenkay.RTM. Cartridge for Tenkay Mark III and IV Collectors Data Sheet—FARR Air Pollution Control, FARR APC, Dec. 2005.  
 Partial Supplemental European Search Report, EP Application No. 12842366.2, Publication 2768599, May 8, 2015.  
 PCT international search report and written opinion of PCT/US2012/051584 dated Jan. 22, 2013.  
 Prosecution history of U.S. Appl. No. 13/275,832 as of Mar. 10, 2014.  
 Office Action with Search Report, CN Application No. 201280062561.3, Feb. 2, 2015.  
 Extended European Search Report, EP Application No. 12842366.2, dated Nov. 12, 2015 (10 pgs.).

*Clark Filter, Inc. v. Camfil USA, Inc., d/b/a Camfil Air Pollution Control*, IPR 2016-00982, filed Apr. 29, 2016.

*Clark Filter, Inc. v. Camfil USA, Inc., d/b/a Camfil Air Pollution Control*, IPR 2016-00987, filed Apr. 29, 2016.

\* cited by examiner

Primary Examiner — Sandra Snapp

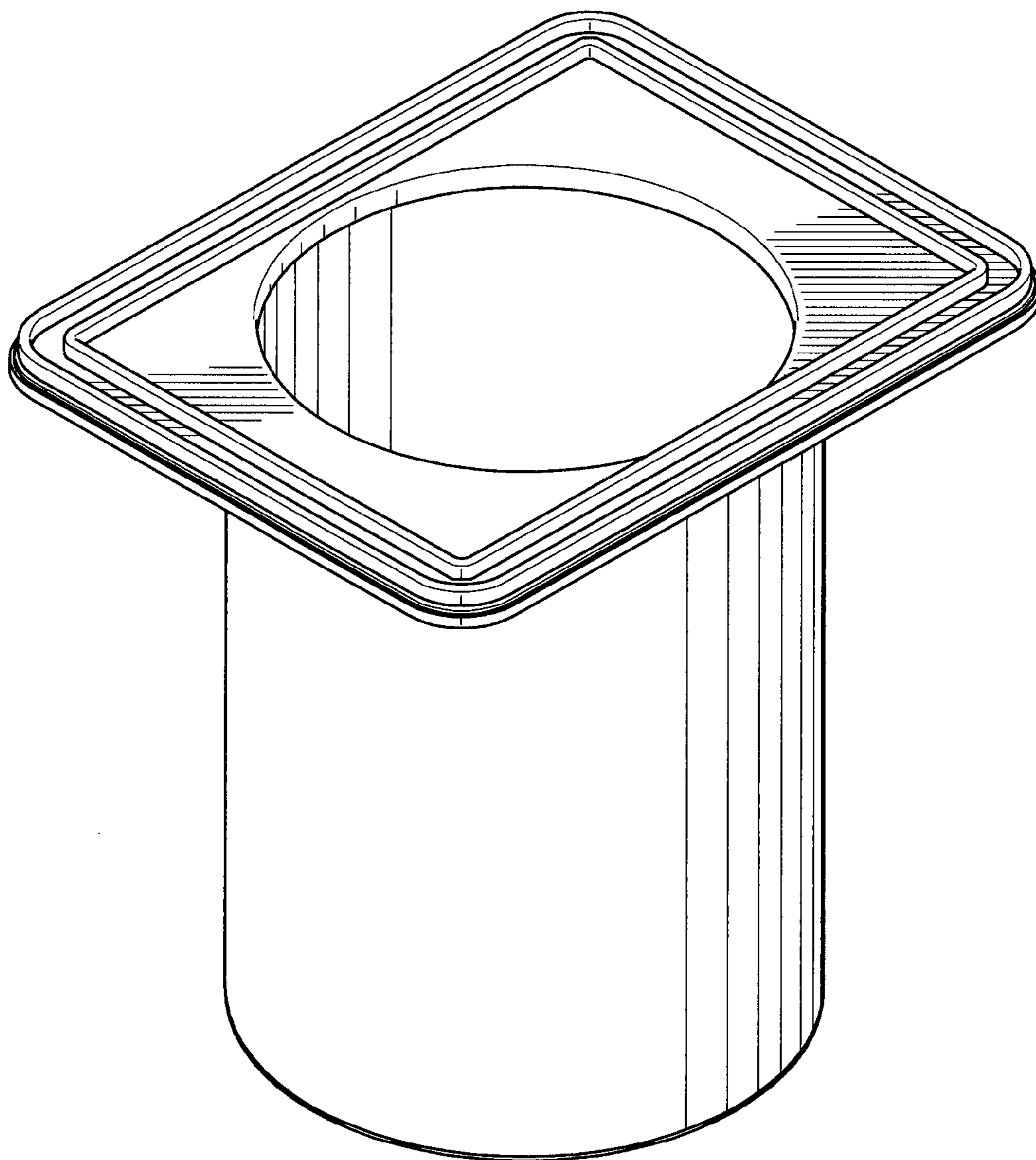
(74) Attorney, Agent, or Firm — Patterson + Sheridan, LLP

(57) CLAIM

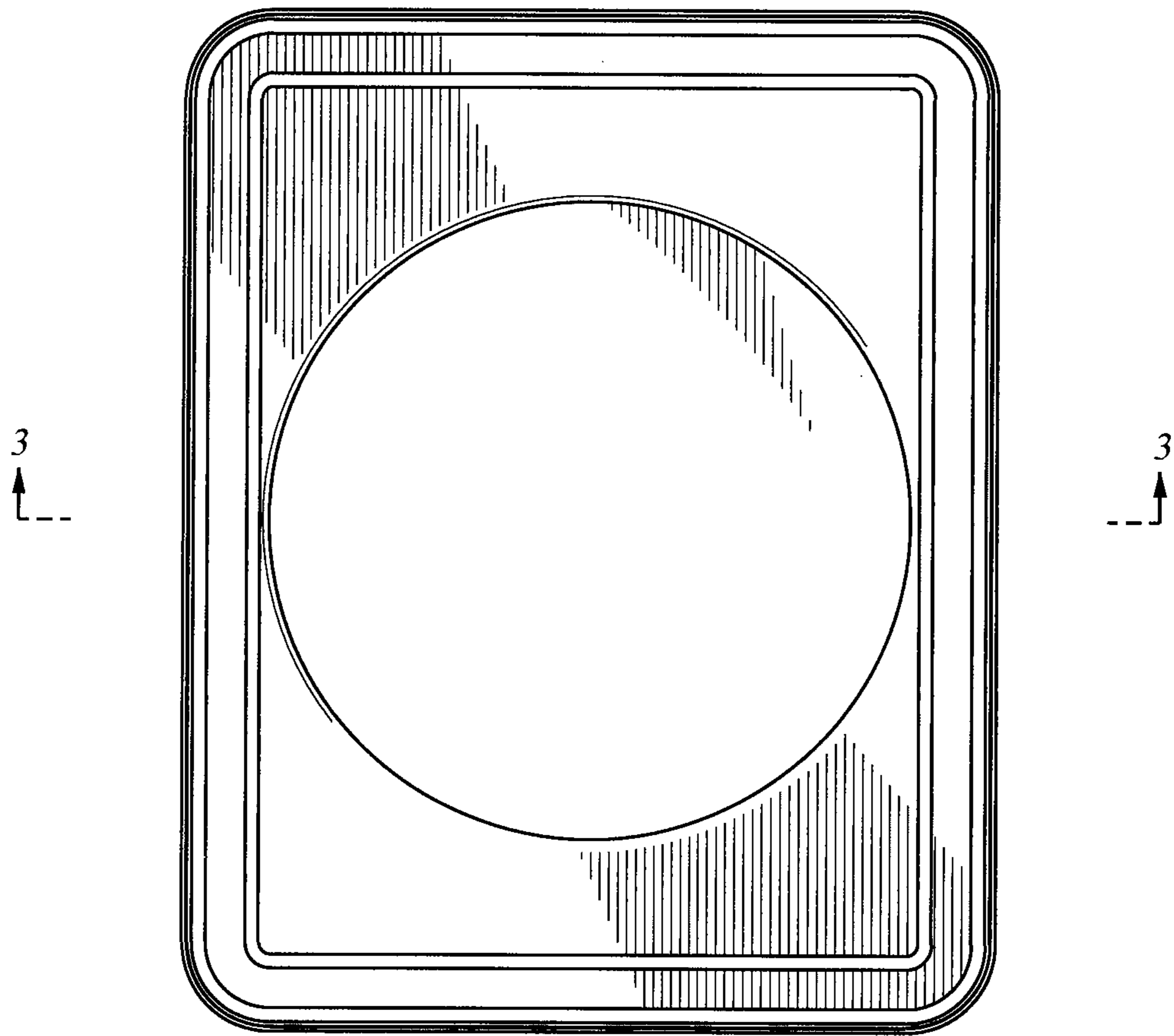
The ornamental design for a filter, as shown and described.

DESCRIPTION

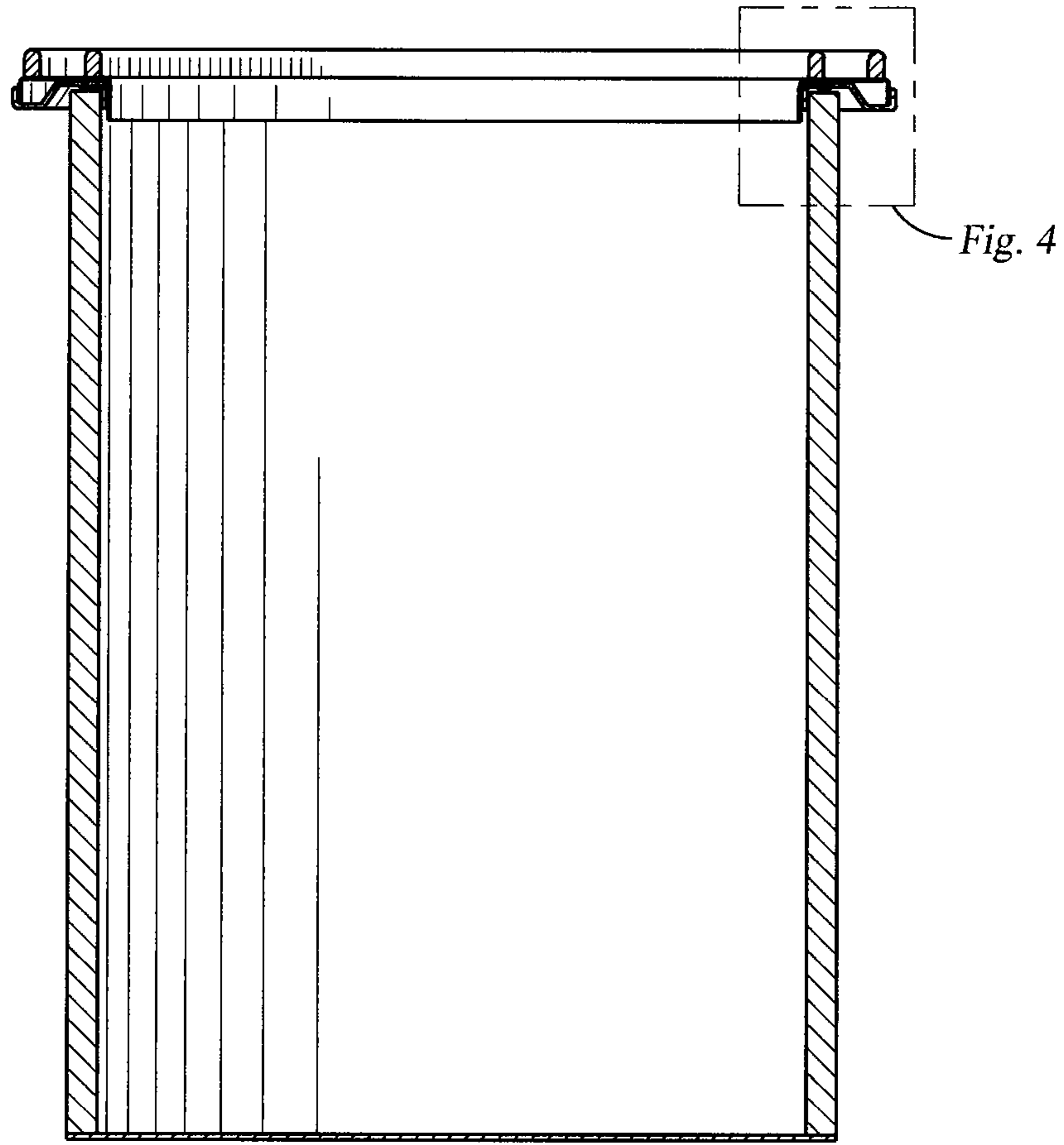
FIG. 1 is a top front perspective view of a filter, according to a first embodiment, showing our new design;  
 FIG. 2 is a top plan view thereof;  
 FIG. 3 is a cross-sectional view thereof taken across line 3-3 of FIG. 2;  
 FIG. 4 is an enlarged portion of the cross-sectional view of FIG. 3;  
 FIG. 5 is a top front perspective view of a filter, according to a second embodiment, showing our new design;  
 FIG. 6 is a top plan view thereof;  
 FIG. 7 is a cross-sectional view thereof taken across line 7-7 of FIG. 6;  
 FIG. 8 is an enlarged portion of the cross-sectional view of FIG. 7;  
 FIG. 9 is a top front perspective view of a filter, according to a third embodiment, showing our new design;  
 FIG. 10 is a top plan view thereof;  
 FIG. 11 is a cross-sectional view thereof taken across line 11-11 of FIG. 10;  
 FIG. 12 is an enlarged portion of the cross-sectional view of FIG. 11;  
 FIG. 13 is a top front perspective view of a filter, according to a fourth embodiment, showing our new design;  
 FIG. 14 is a top plan view thereof;  
 FIG. 15 is a cross-sectional view thereof taken across line 15-15 of FIG. 14;  
 FIG. 16 is an enlarged portion of the cross-sectional view of FIG. 15;  
 FIG. 17 is a top front perspective view of a filter, according to a fifth embodiment, showing our new design;  
 FIG. 18 is a top plan view thereof;  
 FIG. 19 is a cross-sectional view thereof taken across line 19-19 of FIG. 18;  
 FIG. 20 is an enlarged portion of the cross-sectional view of FIG. 19;  
 FIG. 21 is a top front perspective view of a filter, according to a sixth embodiment, showing our new design;  
 FIG. 22 is a top plan view thereof;  
 FIG. 23 is a cross-sectional view thereof taken across line 23-23 of FIG. 22; and,  
 FIG. 24 is an enlarged portion of the cross-sectional view of FIG. 23.  
 The portions illustrated in broken lines form no part of the claimed design.



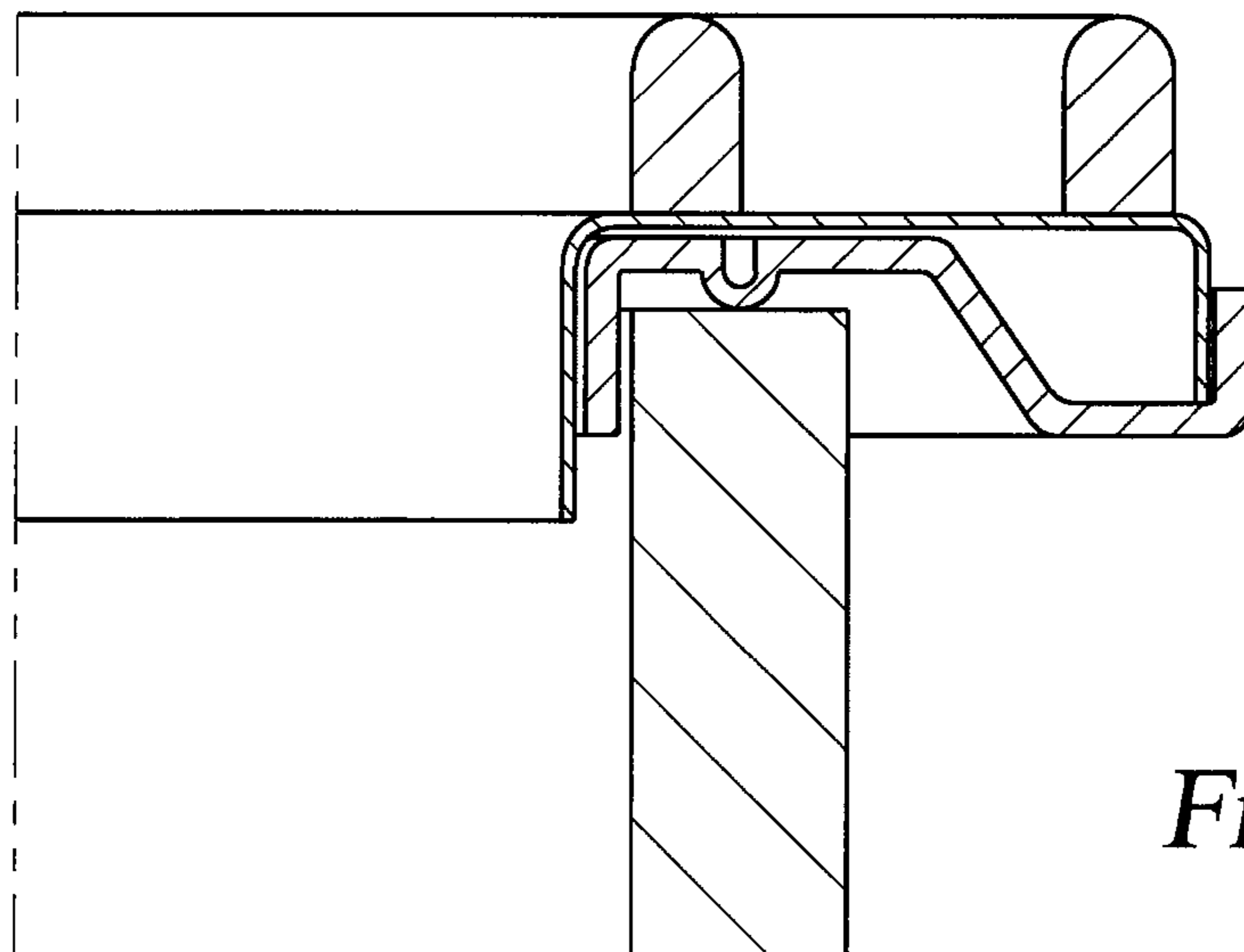
*Fig. 1*



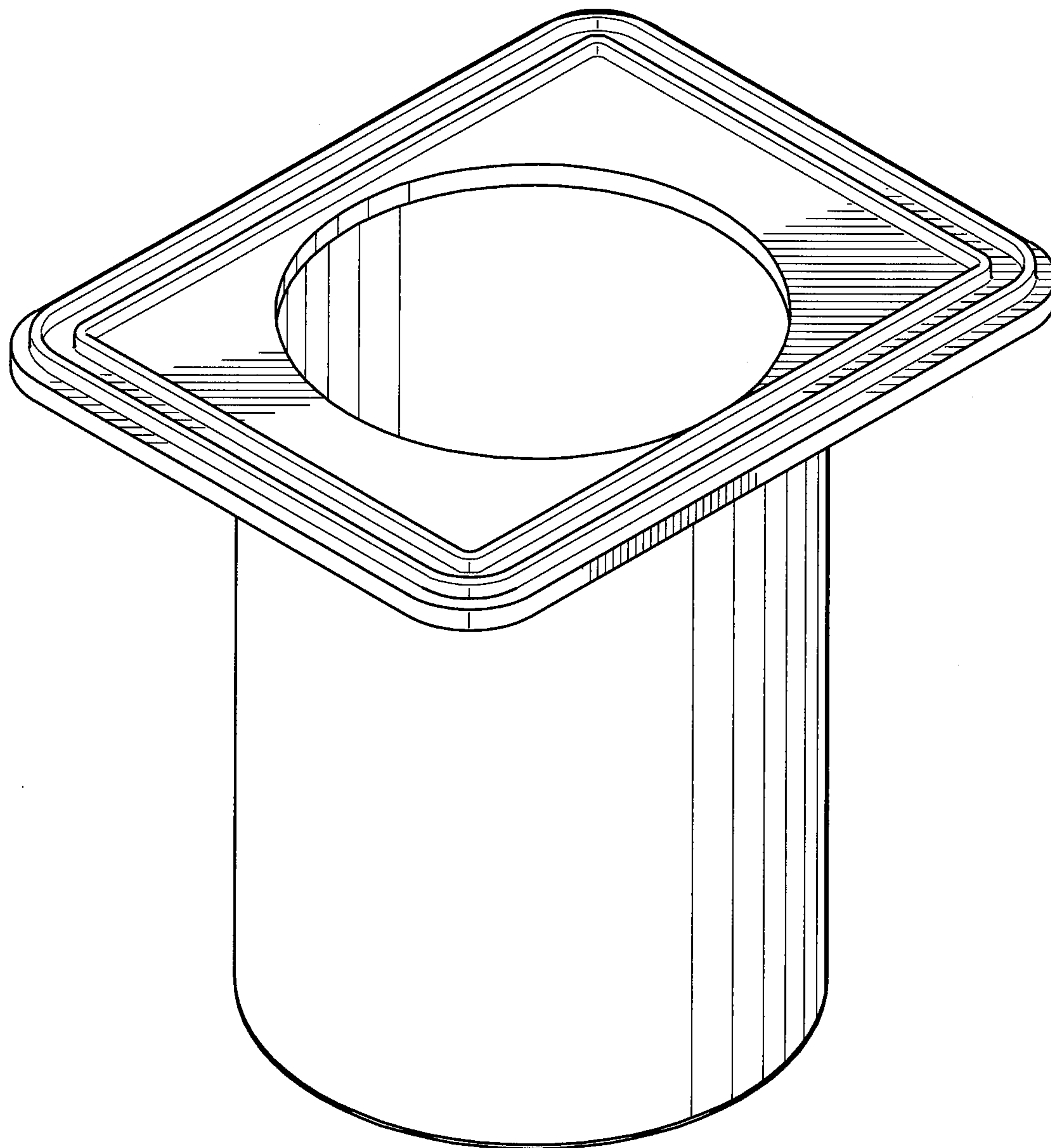
*Fig. 2*



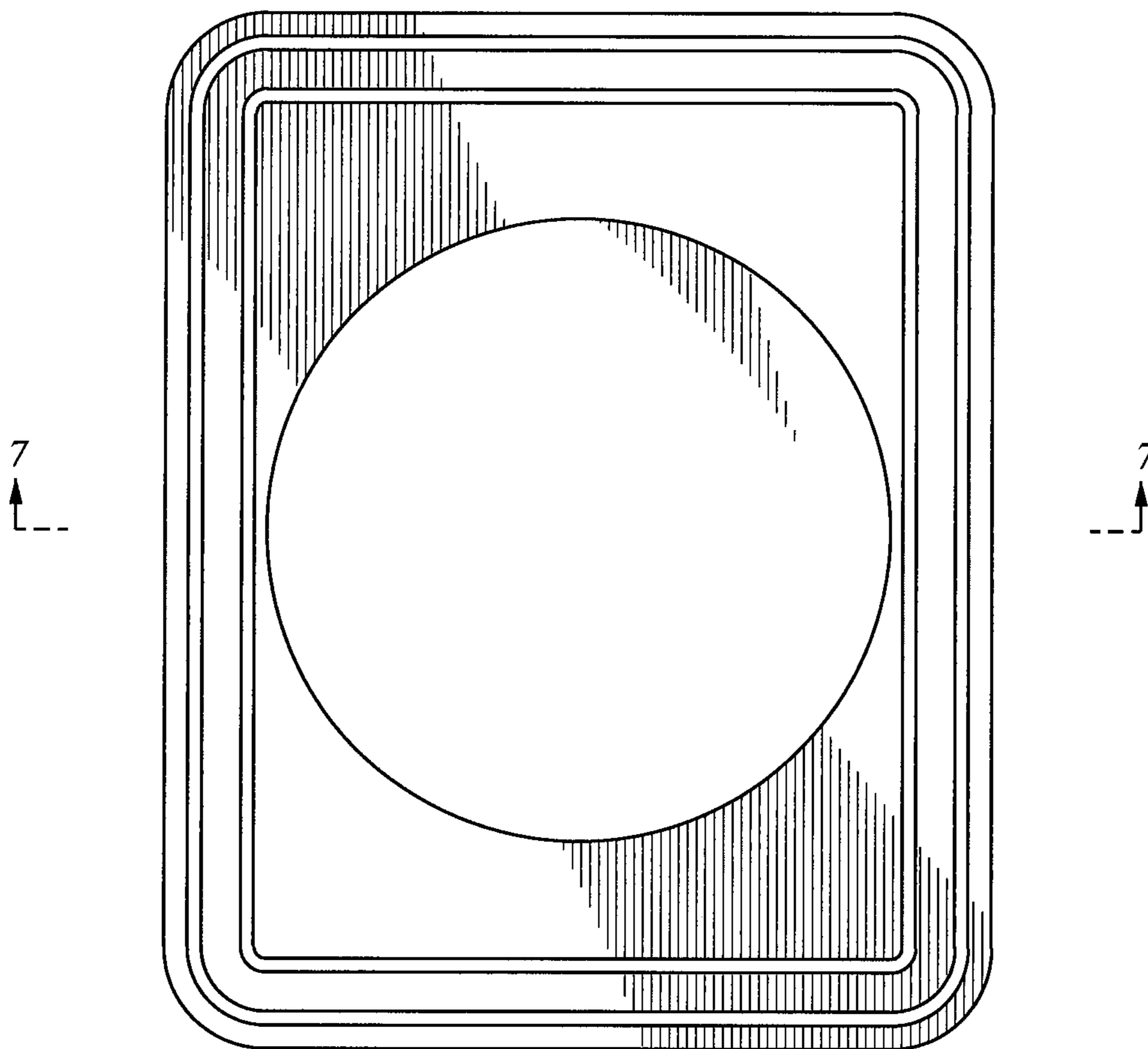
*Fig. 3*



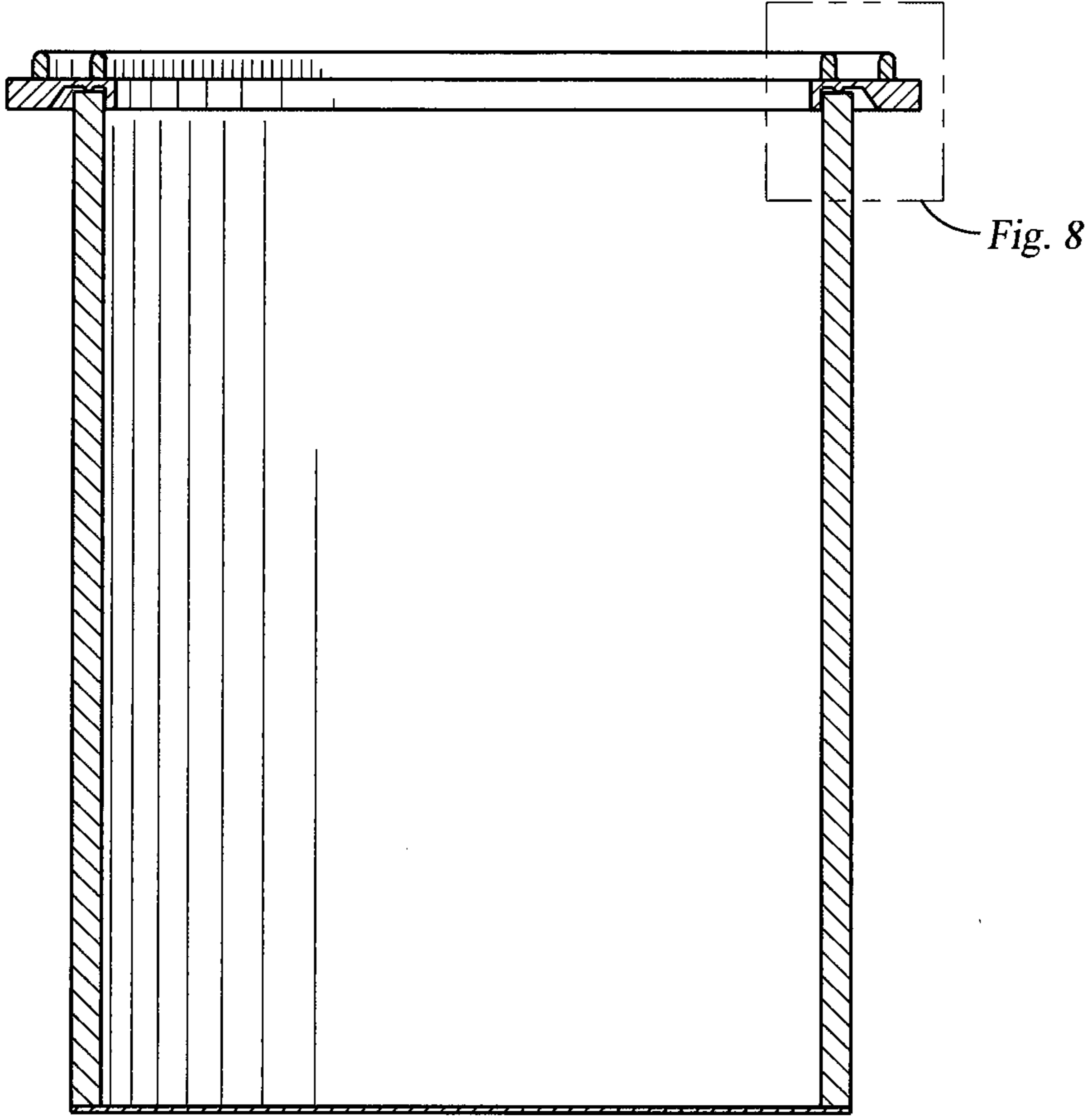
*Fig. 4*



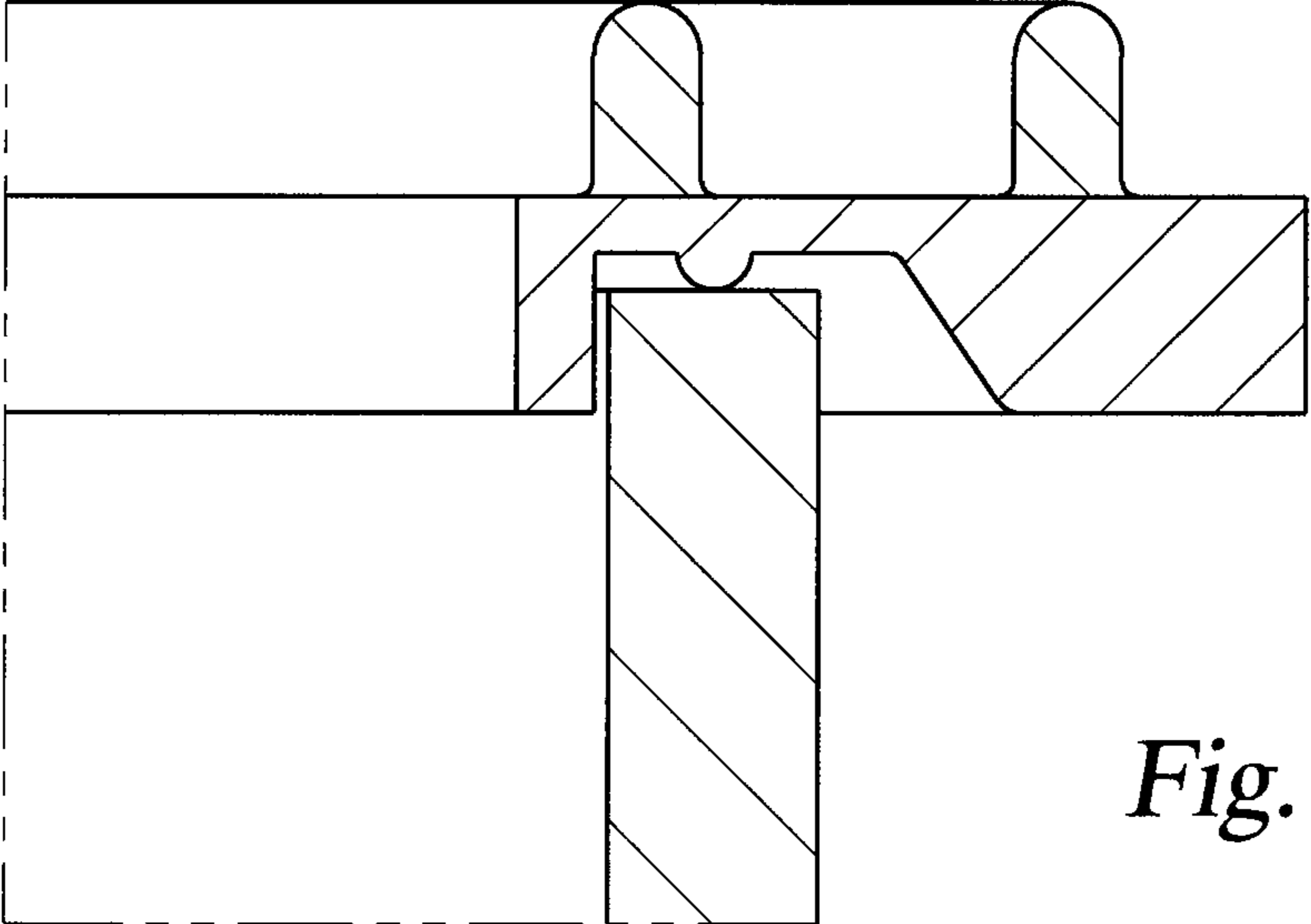
*Fig. 5*



*Fig. 6*

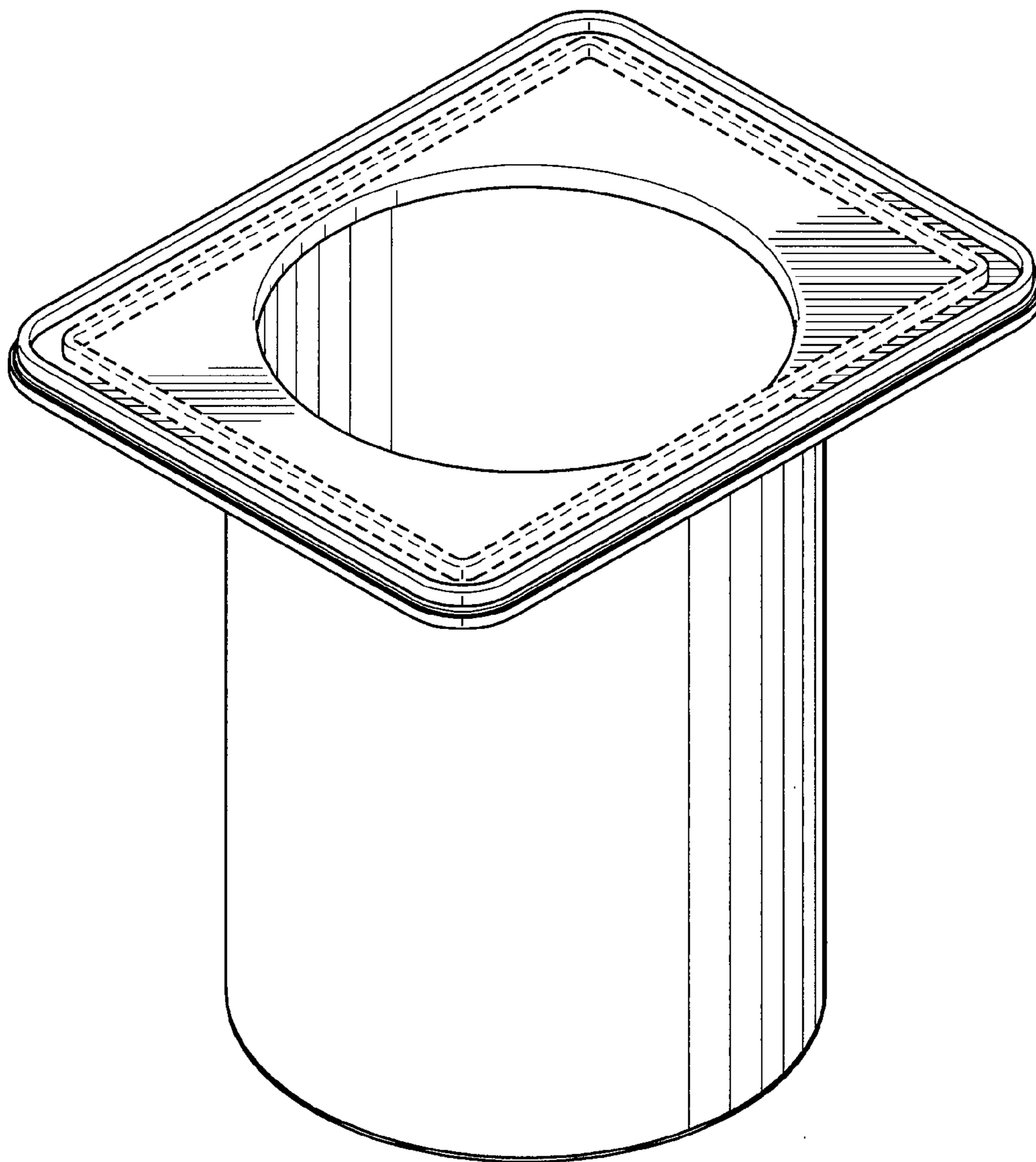


*Fig. 7*

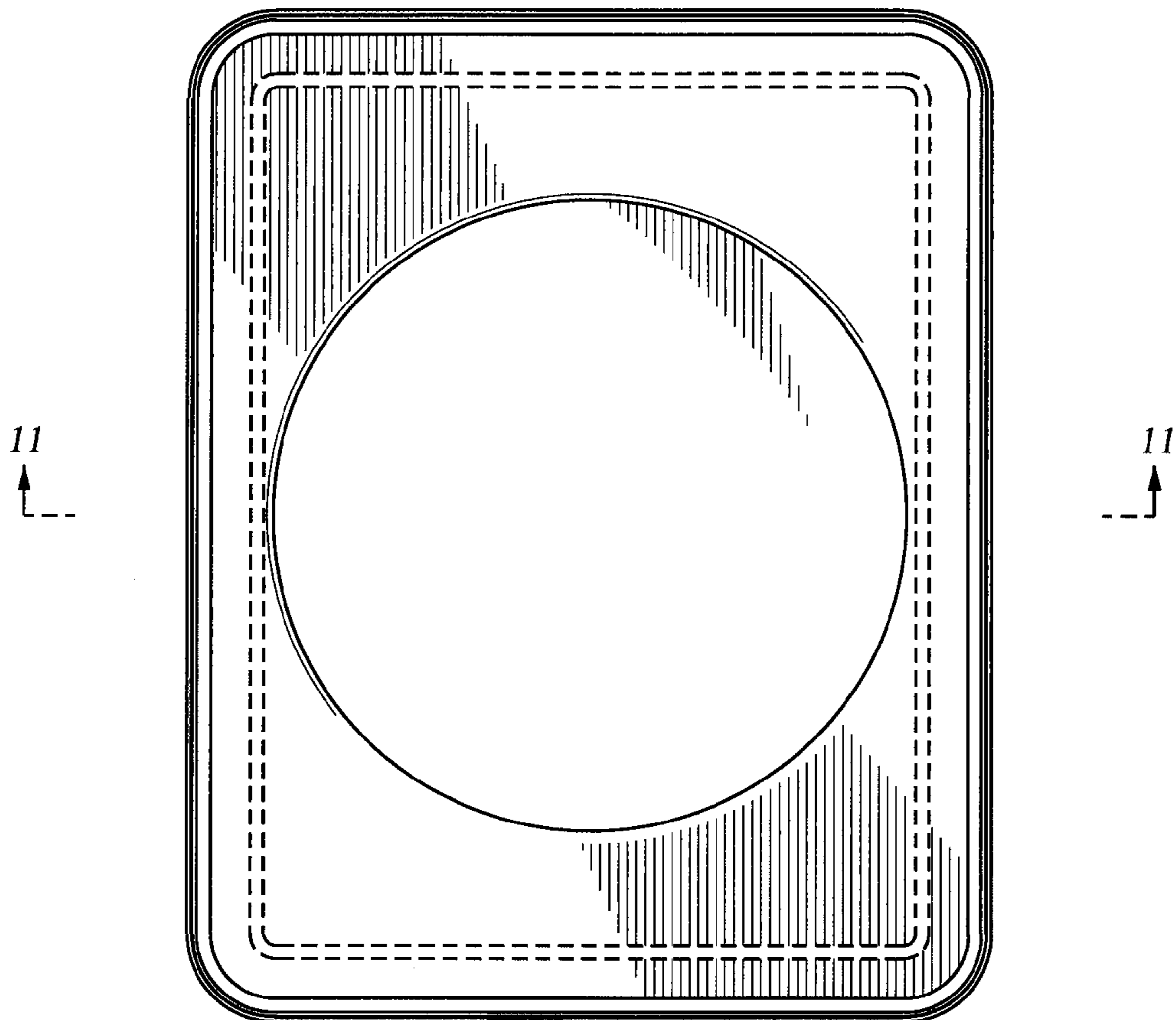


*Fig. 8*

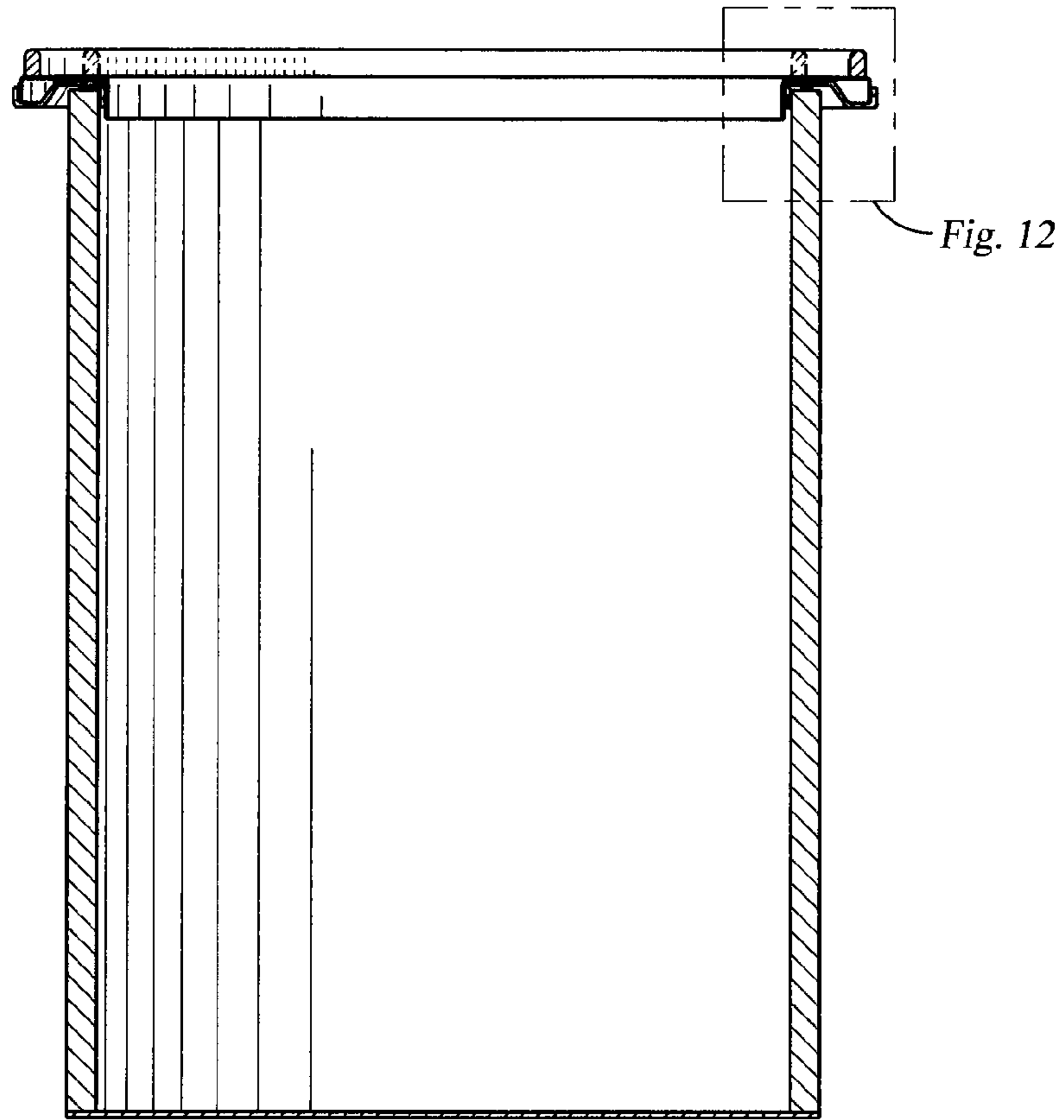




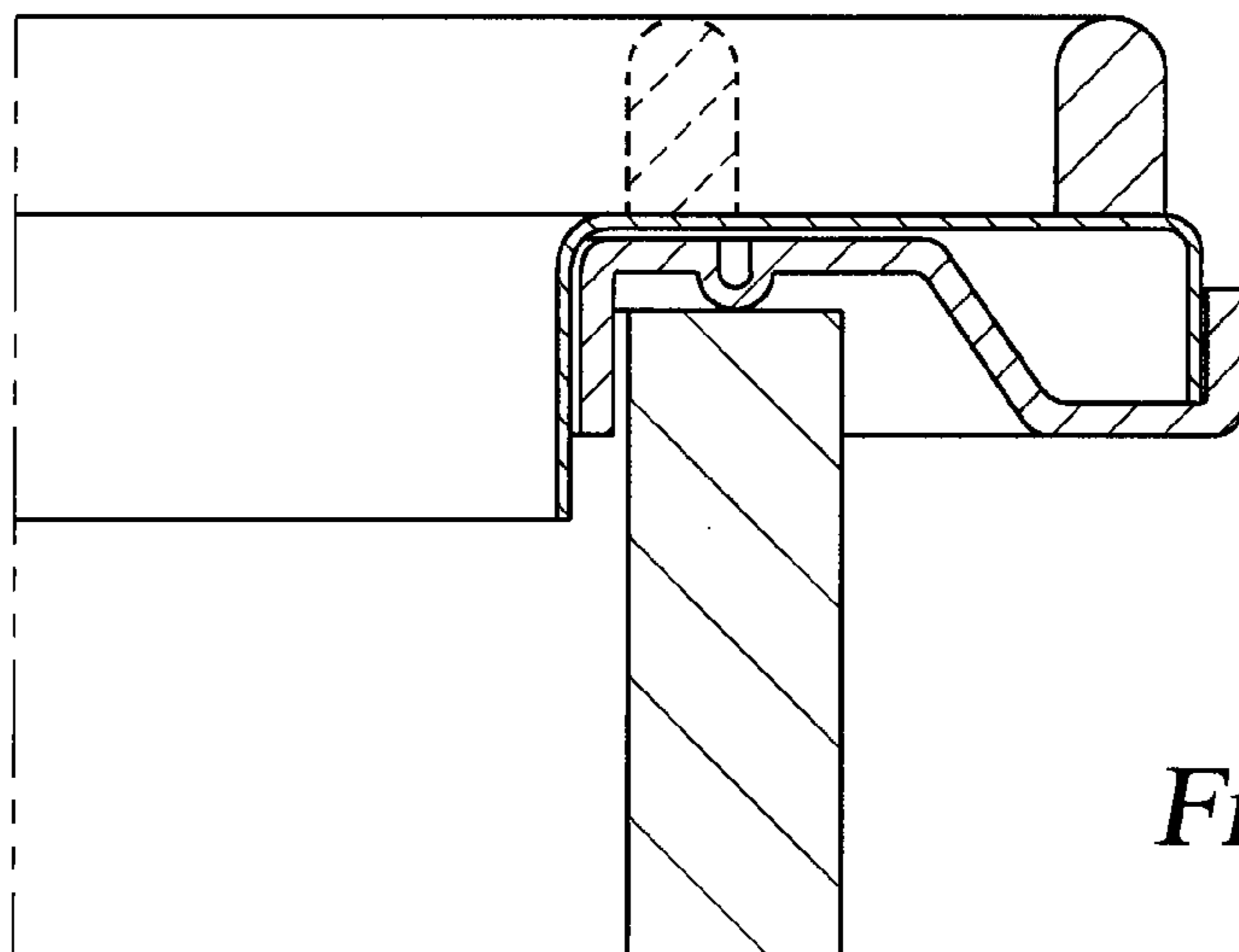
*Fig. 9*



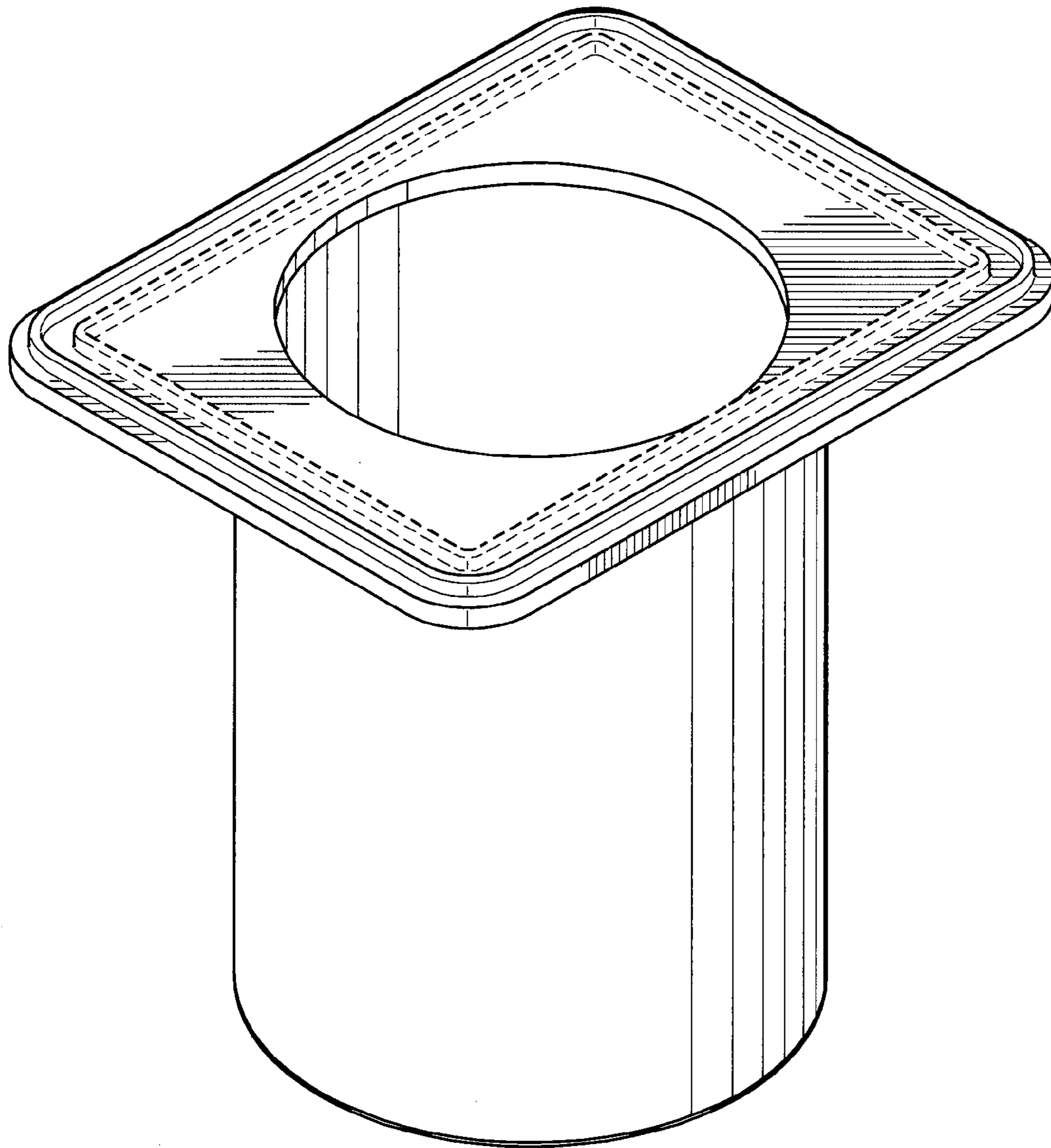
*Fig. 10*



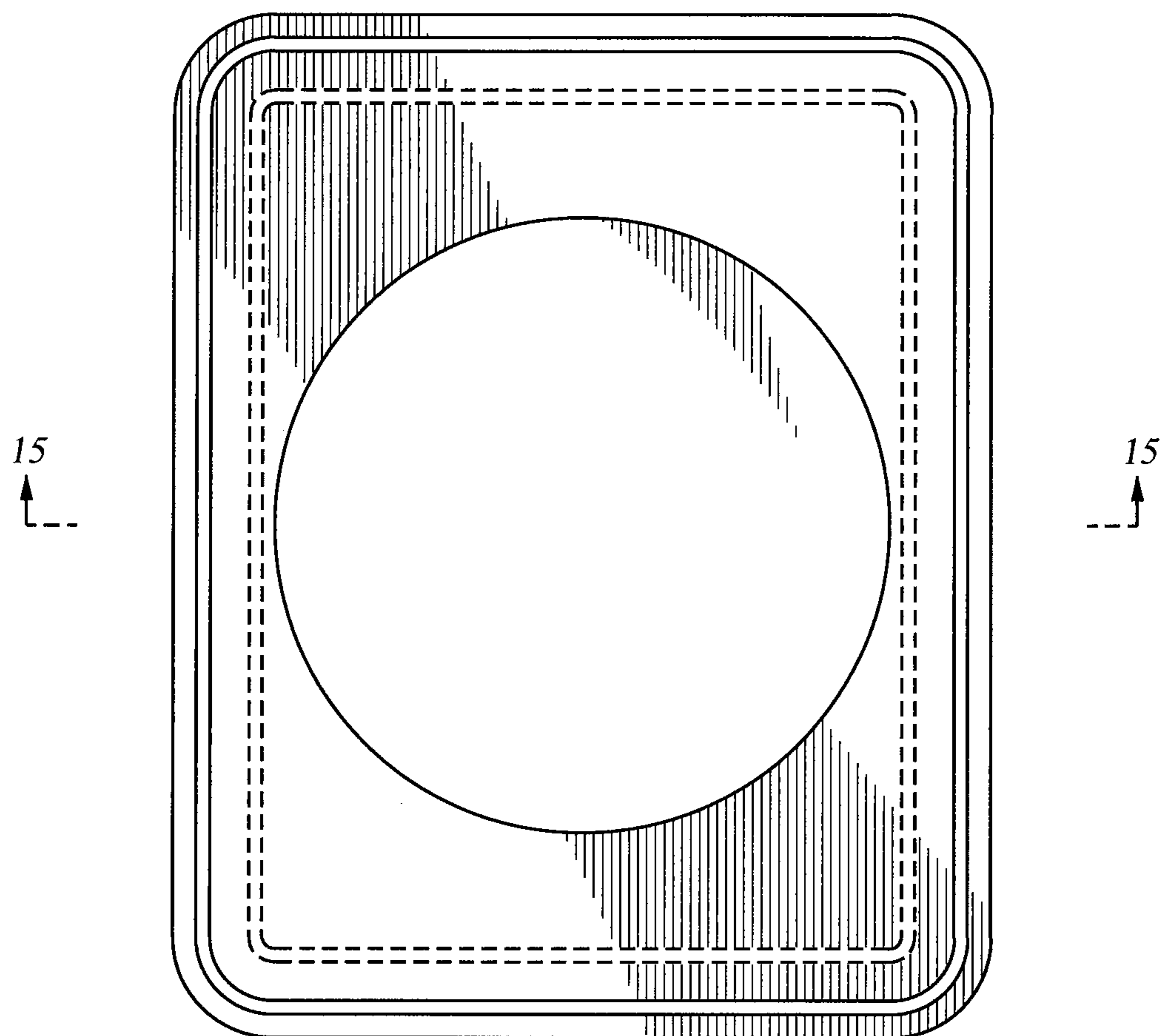
*Fig. 11*



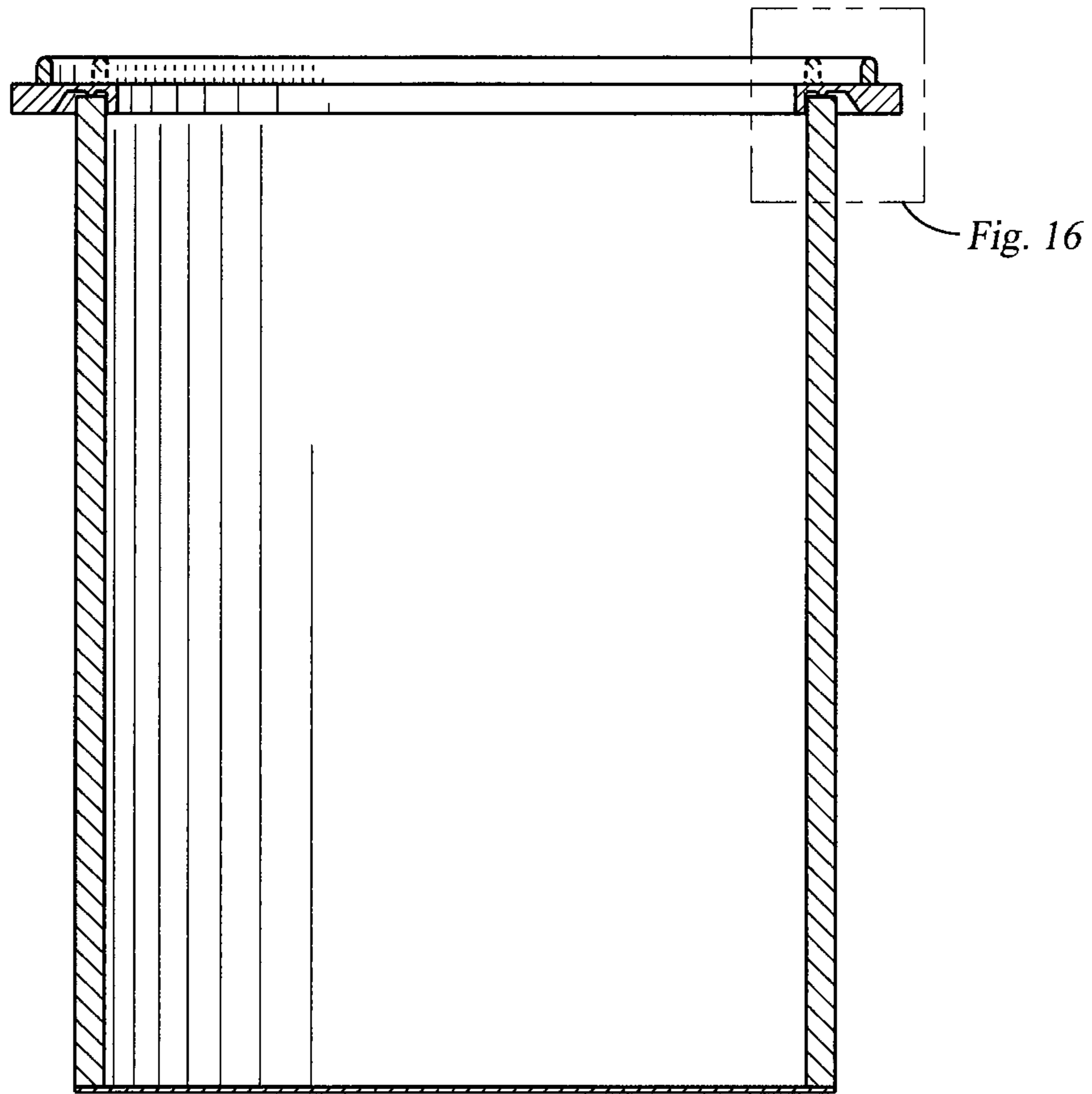
*Fig. 12*



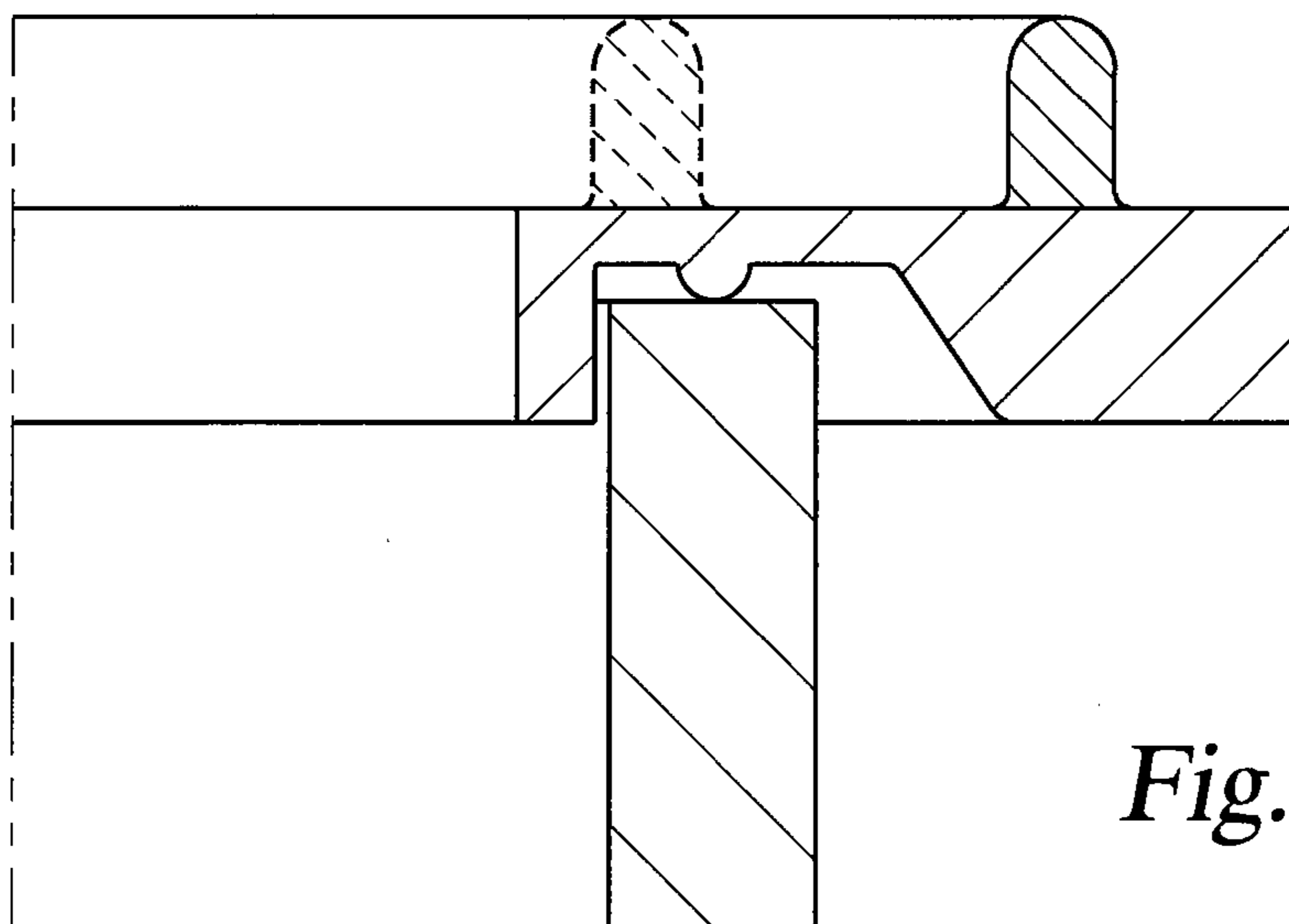
*Fig. 13*



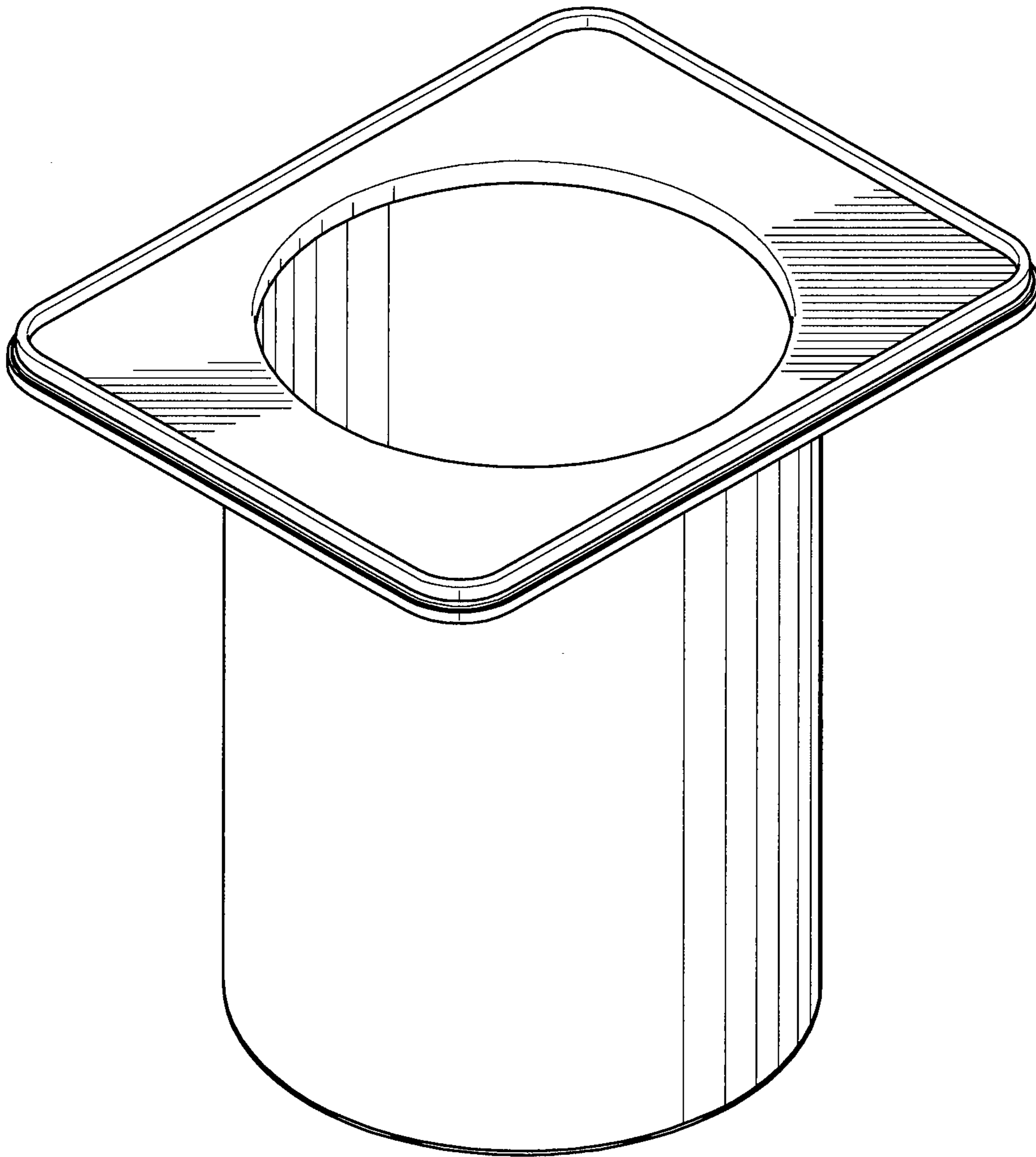
*Fig. 14*



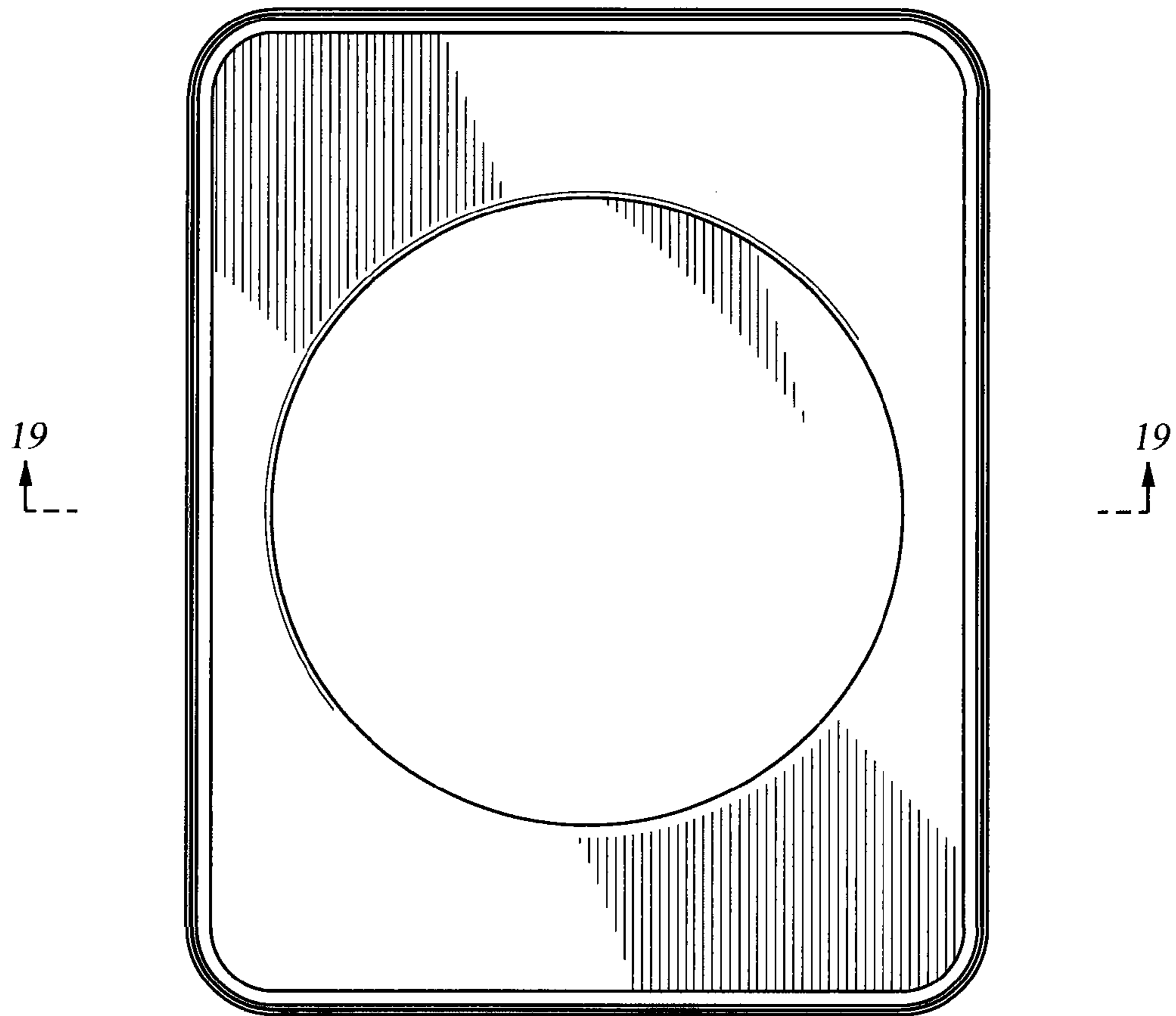
*Fig. 15*



*Fig. 16*

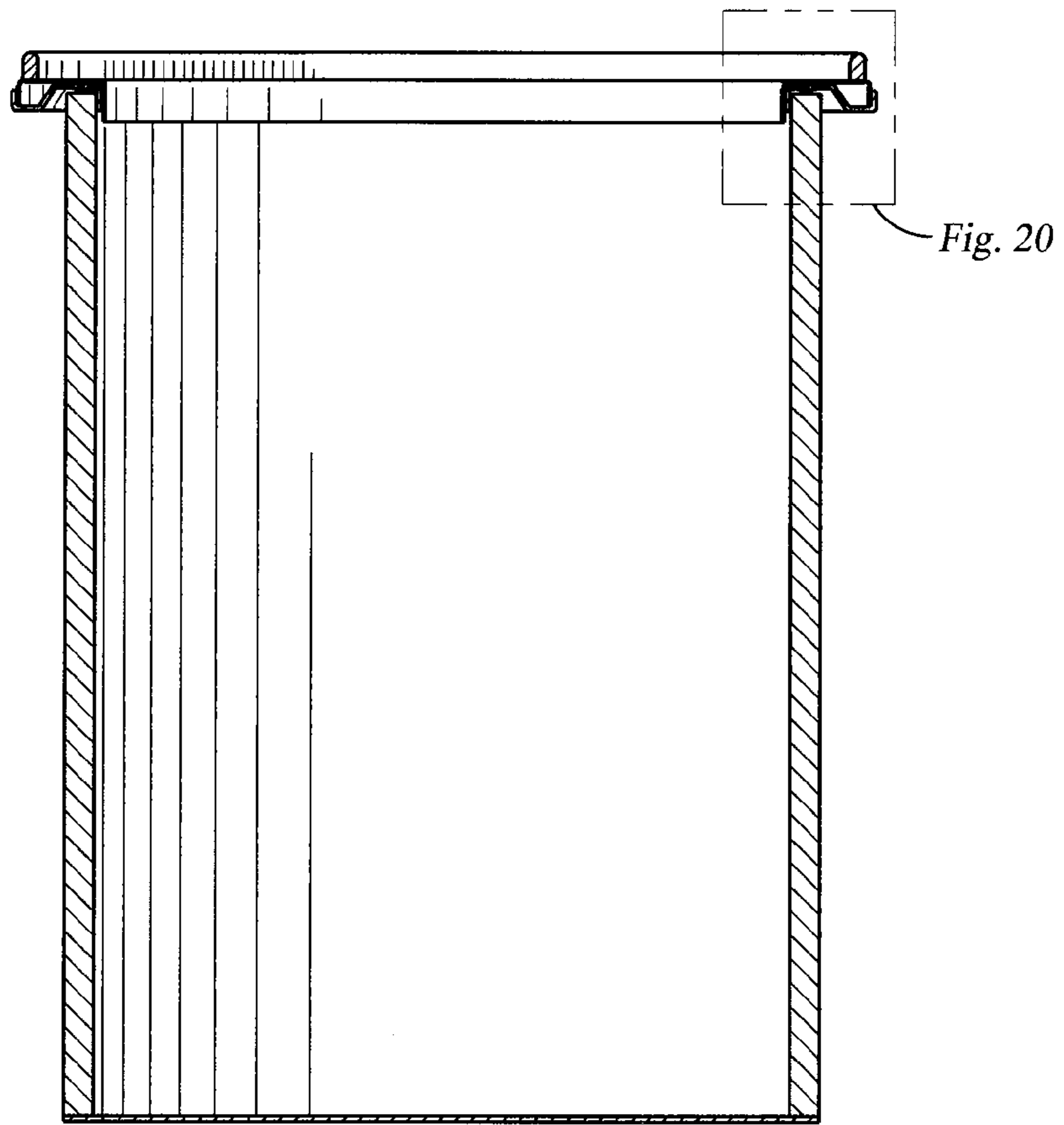


*Fig. 17*

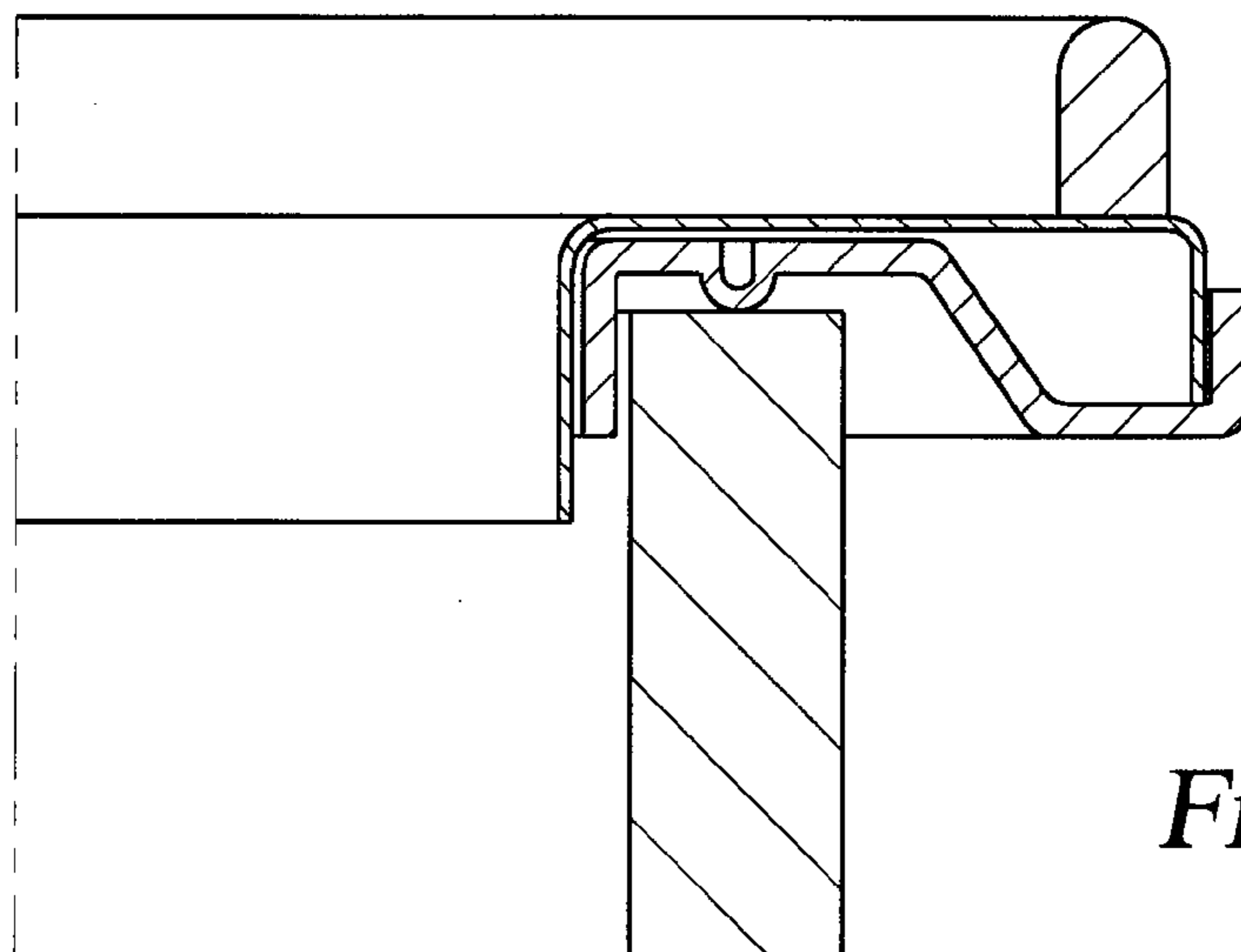


*Fig. 18*

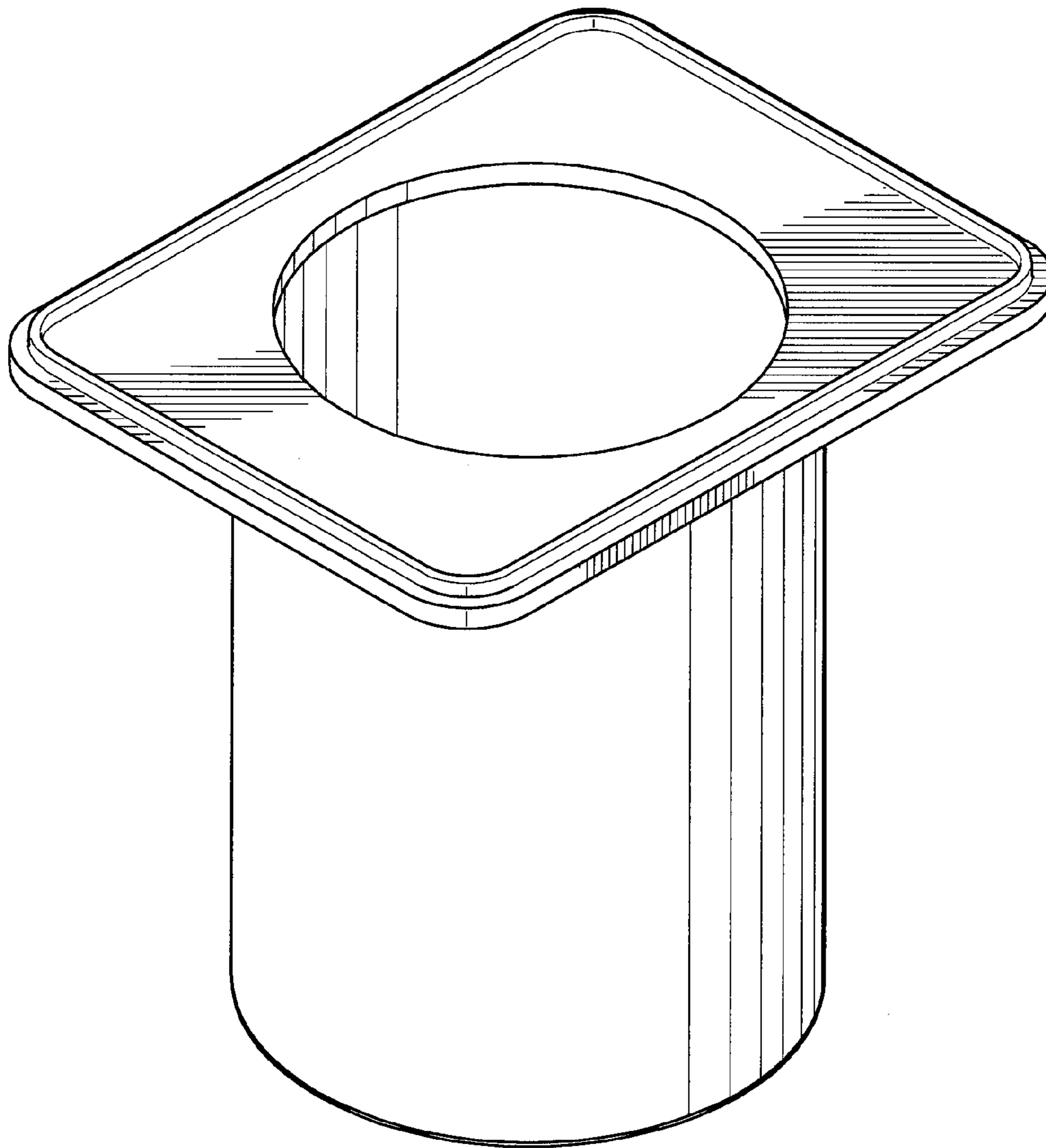




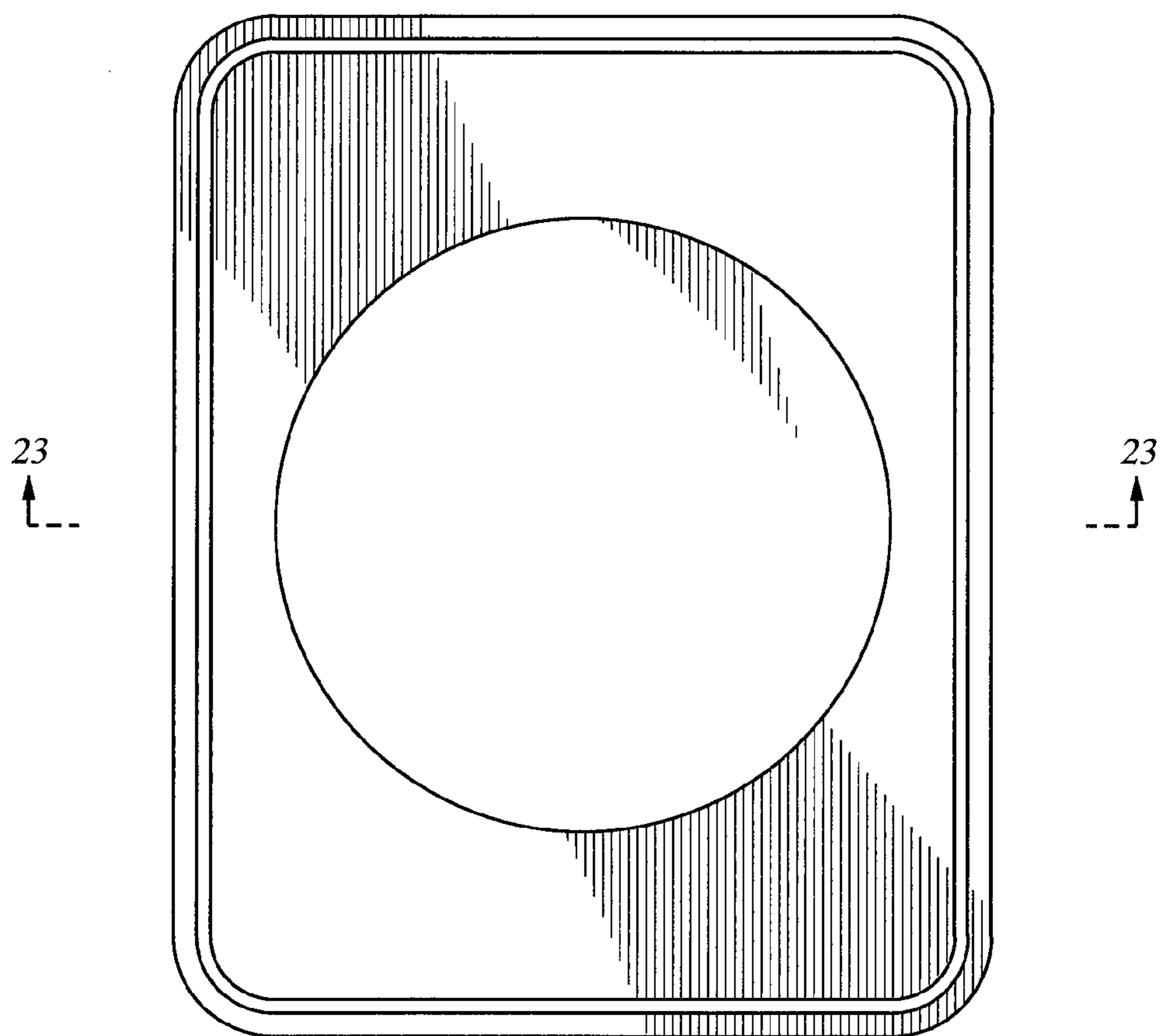
*Fig. 19*



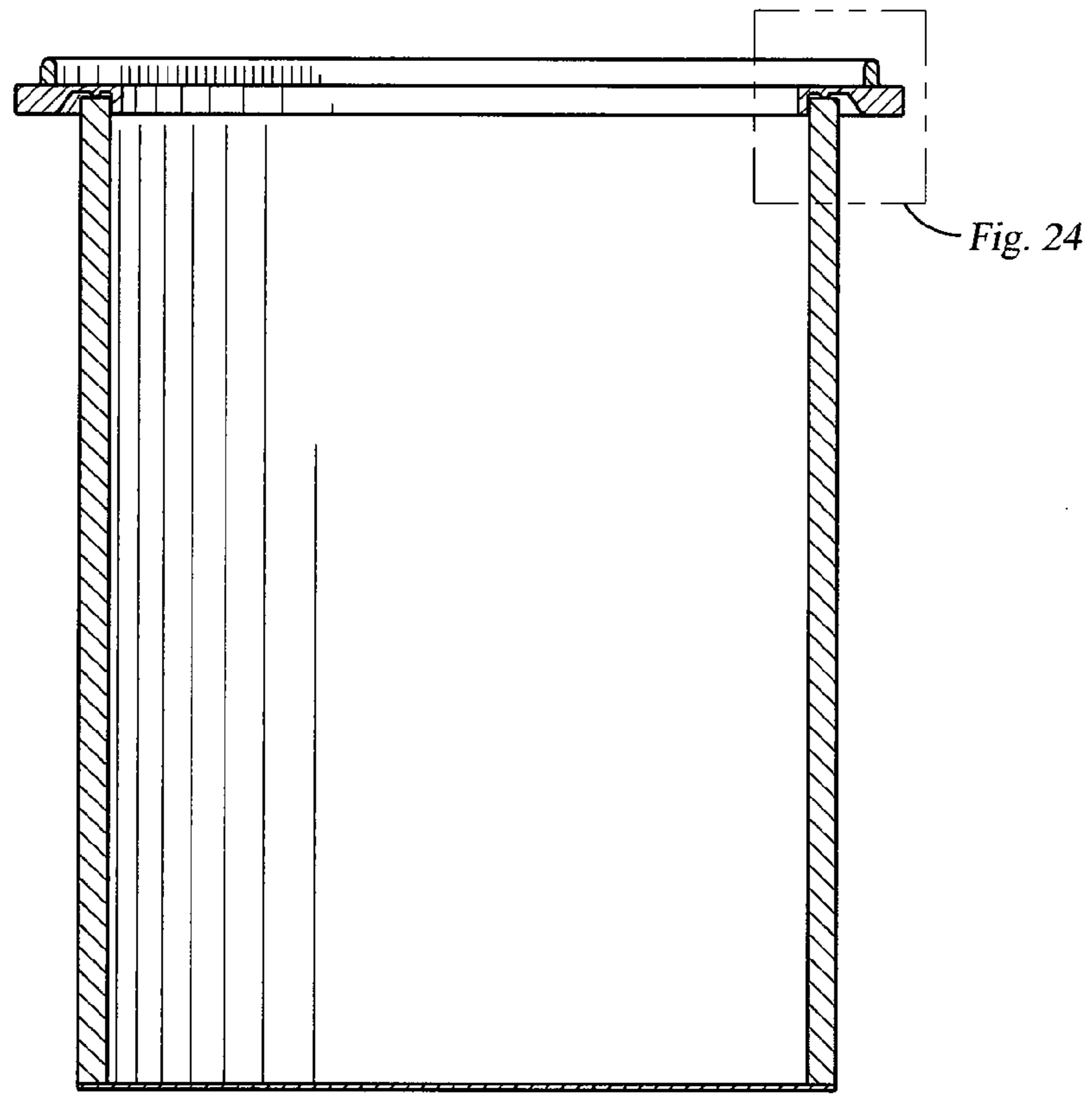
*Fig. 20*



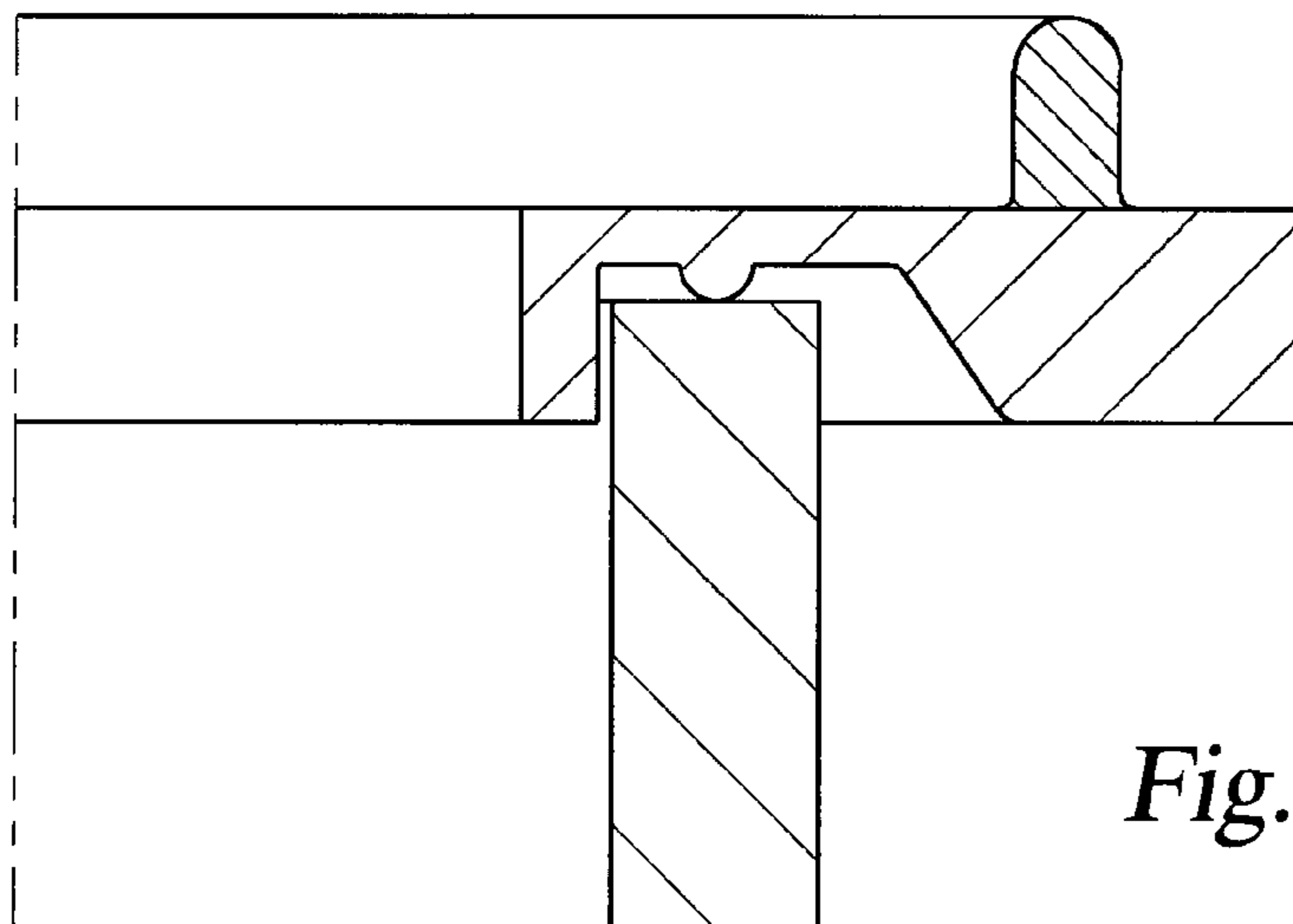
*Fig. 21*



*Fig. 22*



*Fig. 23*



*Fig. 24*