



US00D769779S

(12) **United States Design Patent** (10) **Patent No.:** **US D769,779 S**
Woodhouse et al. (45) **Date of Patent:** **** Oct. 25, 2016**

(54) **VEHICLE FRONT UPPER GRILLE**

(56) **References Cited**

(71) Applicant: **Ford Motor Company**, Dearborn, MI (US)

U.S. PATENT DOCUMENTS

(72) Inventors: **David Woodhouse**, Troy, MI (US);
Shawn Wehrly, West Bloomfield, MI (US); **Moray S Callum**, Ann Arbor, MI (US); **Max Wolff**, Birmingham, MI (US); **Kemal Curic**, West Bloomfield, MI (US)

D708,991 S * 7/2014 Matsuno D12/163
D721,019 S * 1/2015 Pevovar D12/163
D725,555 S * 3/2015 Wolff D12/163

* cited by examiner

(73) Assignee: **Ford Motor Company**, Dearborn, MI (US)

Primary Examiner — Melody N Brown

(74) *Attorney, Agent, or Firm* — Damian Porcari

(**) Term: **14 Years**

(57) **CLAIM**

The ornamental design for a vehicle front upper grille, as shown and described.

(21) Appl. No.: **29/522,298**

DESCRIPTION

(22) Filed: **Mar. 30, 2015**

(51) **LOC (10) Cl.** **12-16**

(52) **U.S. Cl.**
USPC **D12/163**

(58) **Field of Classification Search**
USPC D12/169, 163, 196, 171, 90-92, 216;
293/102, 113, 115, 117, 120;
296/180.1, 180.2; 180/68.1, 68.6
CPC .. B60R 19/52; B60R 2019/25; B62D 25/084
See application file for complete search history.

FIG. 1 is a left perspective view of a vehicle front upper grille;
FIG. 2 is a right perspective view thereof;
FIG. 3 is a rear left perspective view thereof;
FIG. 4 is a front elevational view thereof;
FIG. 5 is a rear elevational view thereof;
FIG. 6 is a left side elevational view thereof;
FIG. 7 is a right side elevational view thereof;
FIG. 8 is a top plan view thereof; and,
FIG. 9 is a bottom plan view thereof.

1 Claim, 9 Drawing Sheets

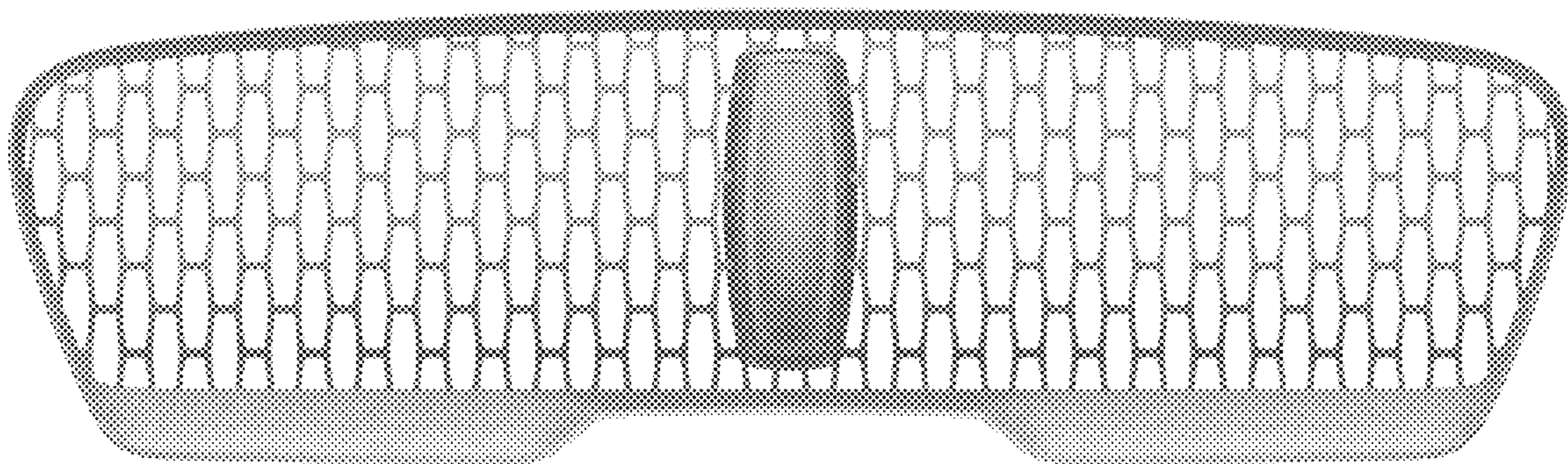

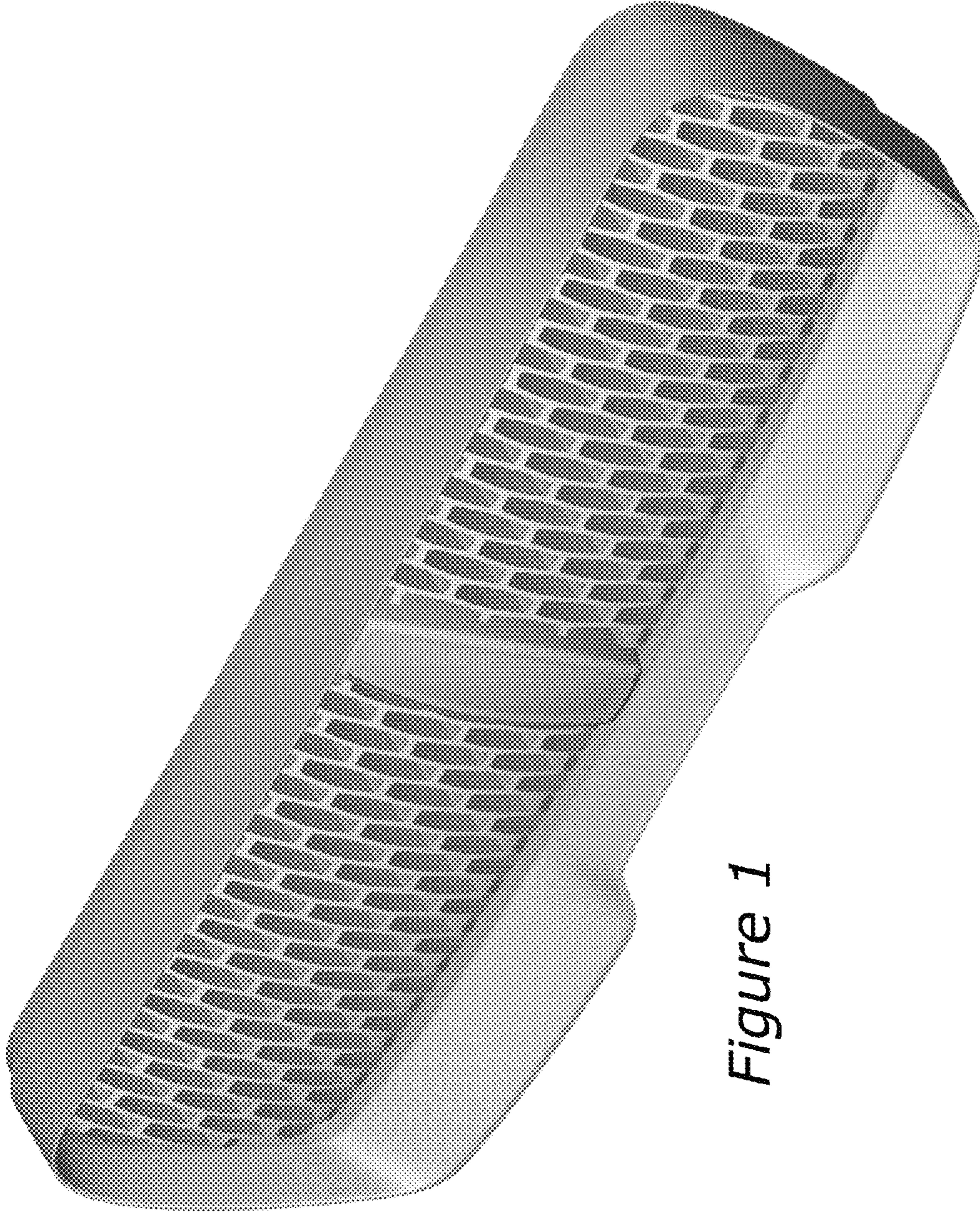

Figure 1

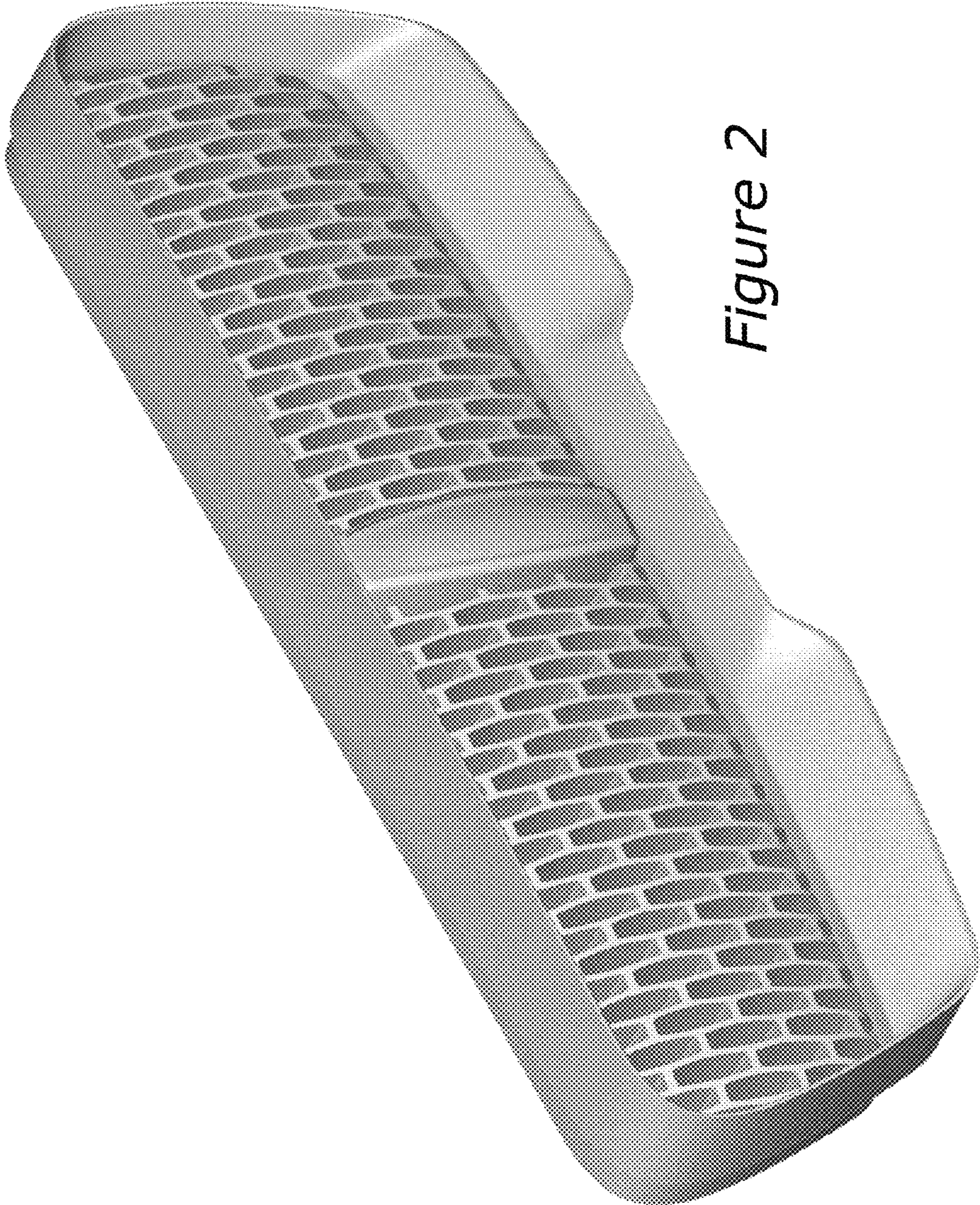

Figure 2

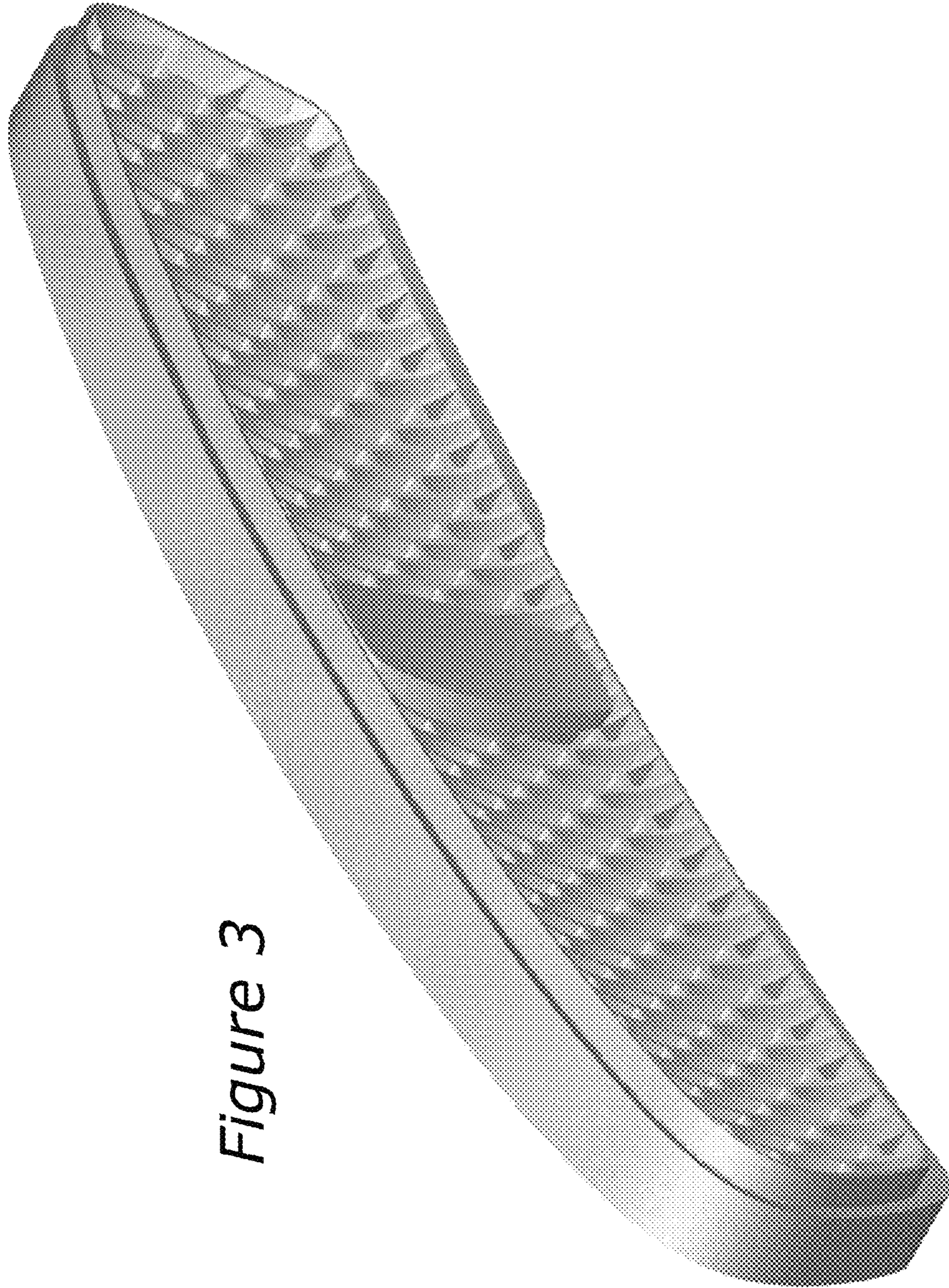

Figure 3

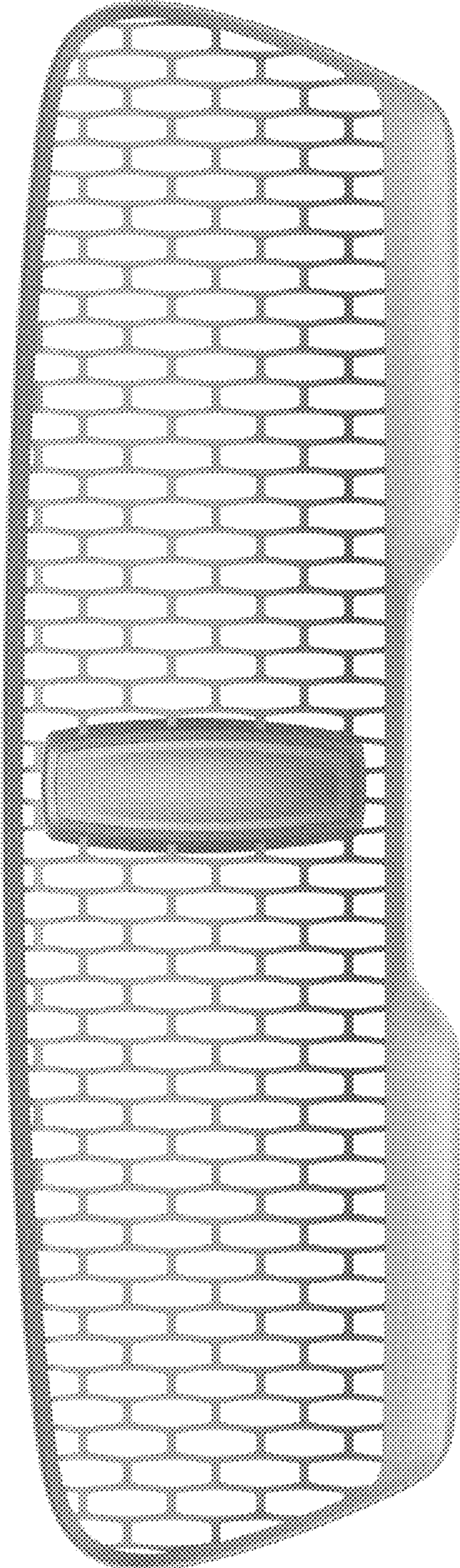

Figure 4

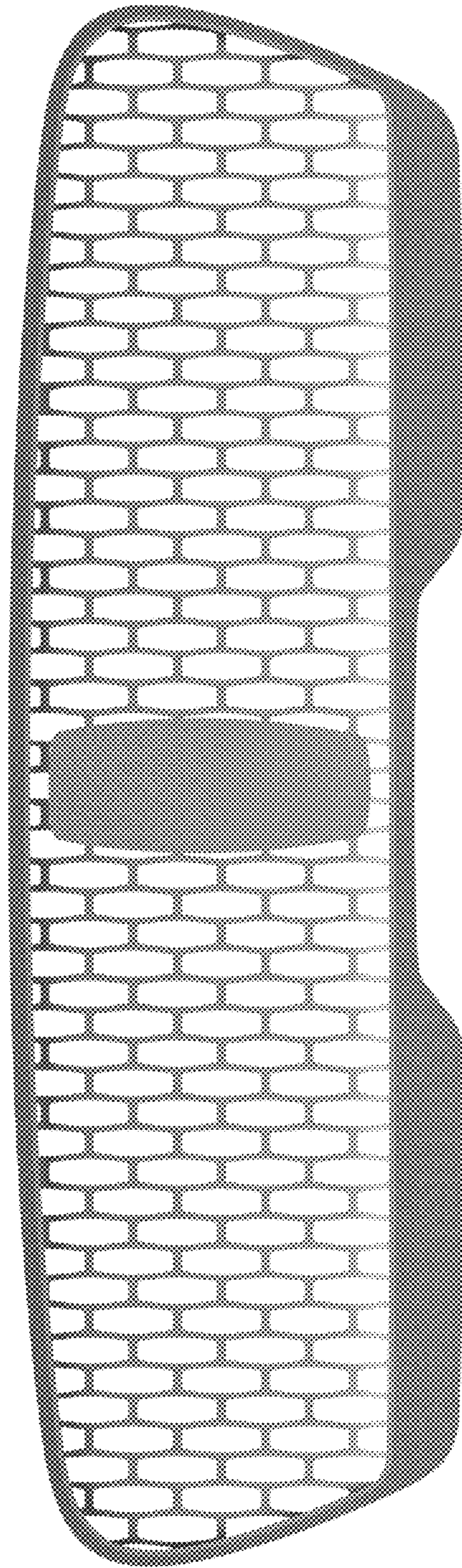

Figure 5

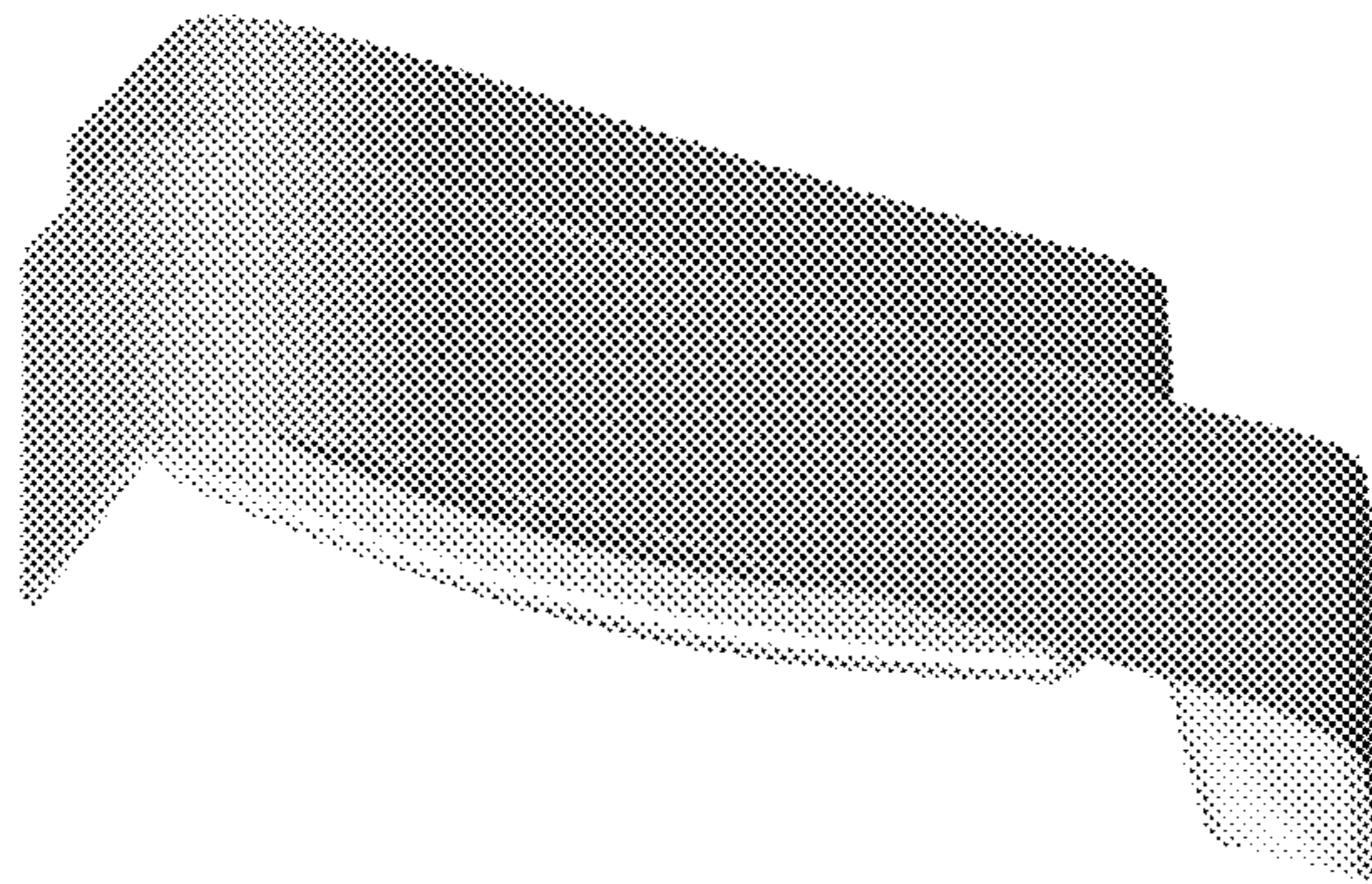

Figure 6

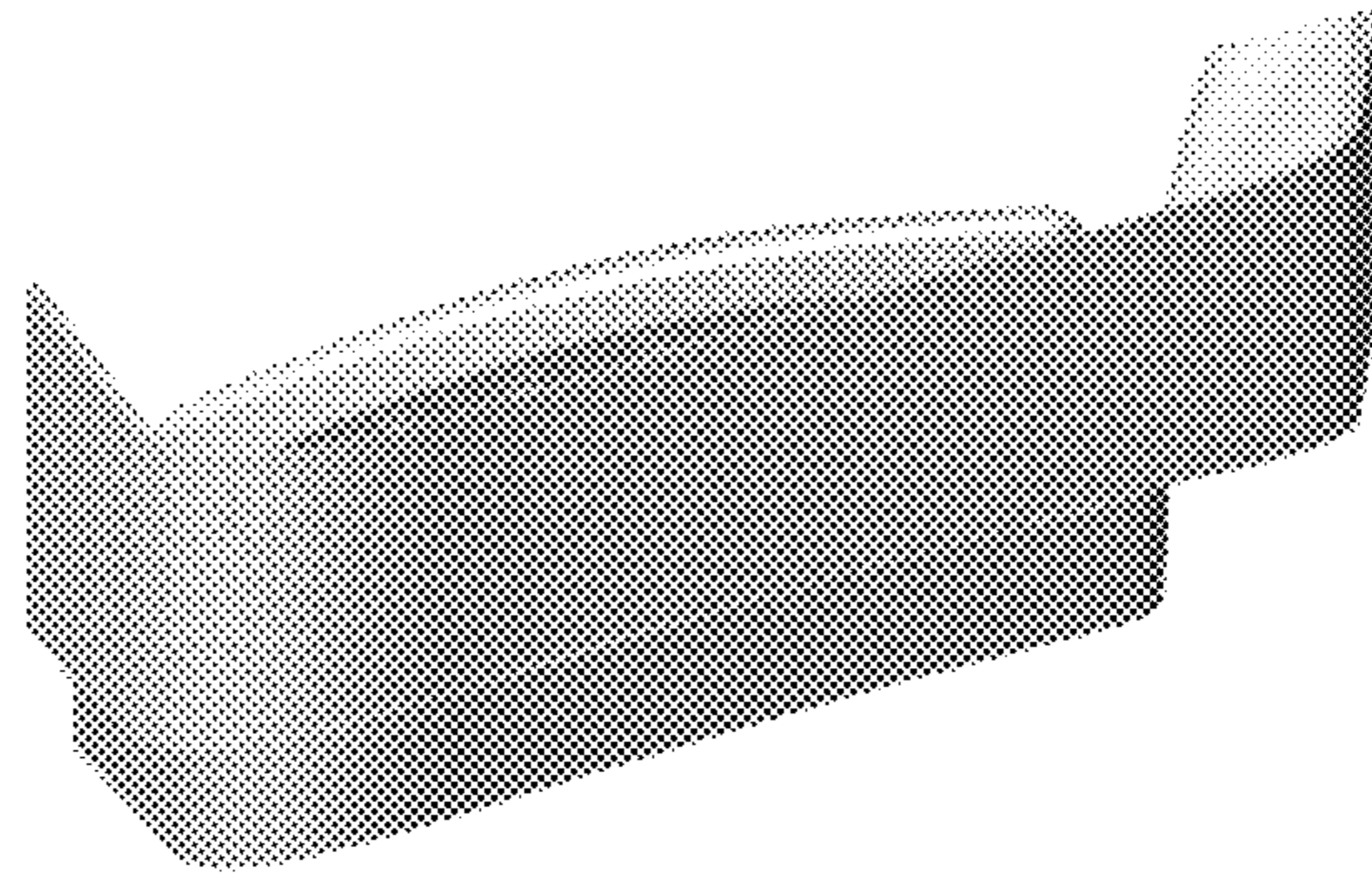

Figure 7

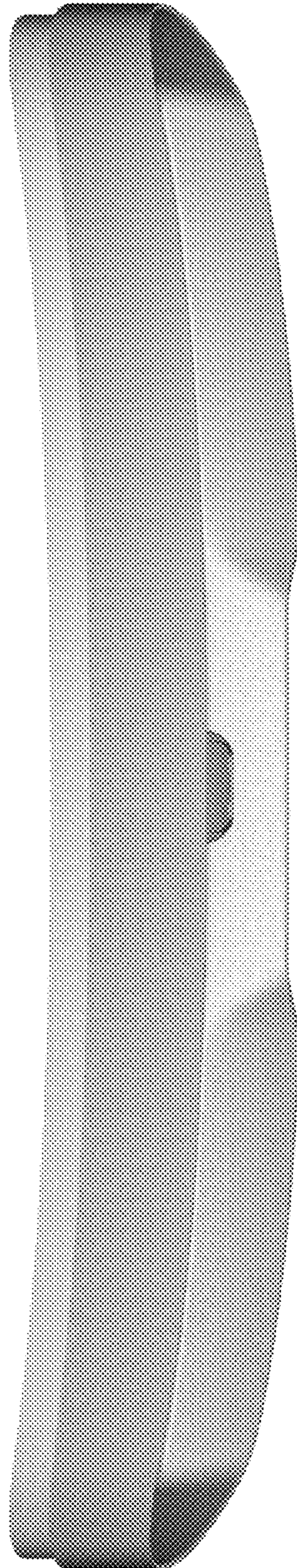

Figure 8

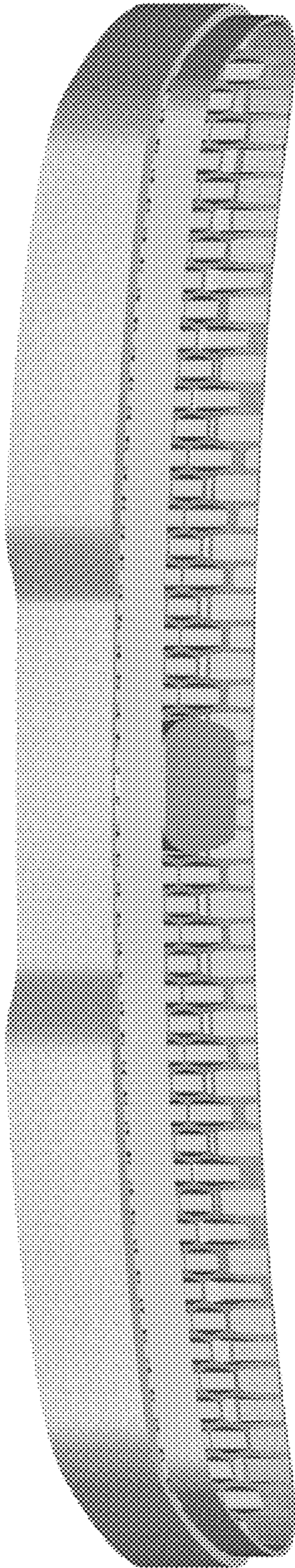

Figure 9