



US00D769725S

(12) **United States Design Patent**
Citterio

(10) **Patent No.:** **US D769,725 S**

(45) **Date of Patent:** **** Oct. 25, 2016**

(54) **BOTTLE**

(71) Applicant: **ITF S.p.A.**, Milan (IT)

(72) Inventor: **Antonio Citterio**, Milan (IT)

(73) Assignee: **ITF S.P.A.**, Milan (IT)

(**) Term: **14 Years**

(21) Appl. No.: **29/467,040**

(22) Filed: **Sep. 13, 2013**

(30) **Foreign Application Priority Data**

Mar. 18, 2013 (EM) 002204172-0001

(51) **LOC (10) Cl.** **09-01**

(52) **U.S. Cl.**
USPC **D9/564**; D9/444; D9/574

(58) **Field of Classification Search**
USPC D9/434-435, 439, 444-445, 516, 544,
D9/546, 564, 572-574, 682, 686-687, 694,
D9/715, 719; D7/300, 300.1, 316, 598;
D28/91.1

CPC B65D 1/00; B65D 1/02; B65D 1/0223;
B65D 23/00; B65D 83/00; B65D 83/14;
B65D 83/20; B65D 83/38; B65D 2501/00;
B65D 2501/0009; B65D 2501/0081; B05B
11/0037

See application file for complete search history.

(56) **References Cited**

U.S. PATENT DOCUMENTS

D112,782 S * 1/1939 McIntosh D9/564
D156,089 S * 11/1949 Fuerst D9/564

D279,079 S * 6/1985 Pourtout D9/553
D363,226 S * 10/1995 Trussardi D9/544
D375,675 S * 11/1996 Luzzi et al. D9/689
D379,311 S * 5/1997 Crawford D9/542
D380,390 S * 7/1997 Varlet D9/558
D398,242 S * 9/1998 Fling et al. D9/545
D434,645 S * 12/2000 Adachi et al. D9/694
D573,479 S * 7/2008 Varlet D9/544
D575,163 S * 8/2008 Venturini Fendi D9/636
D600,133 S * 9/2009 Friedman et al. D9/560
D606,415 S * 12/2009 Lavigne et al. D9/546
D696,080 S * 12/2013 Joy D7/629

* cited by examiner

Primary Examiner — Dana L Meyrow

(74) *Attorney, Agent, or Firm* — Hedman & Costigan,
P.C.; James V. Costigan; Kathleen A. Costigan

(57) **CLAIM**

The ornamental design for a bottle, as shown and described.

DESCRIPTION

FIG. 1 is a front, right side perspective view of my design;
FIG. 2 is a front view thereof;
FIG. 3 is a back view thereof;
FIG. 4 is a left side view thereof;
FIG. 5 is a right side view thereof;
FIG. 6 is a top view thereof; and,
FIG. 7 is a bottom view thereof.

The broken lines in the drawings and the unshaded areas within the broken lines illustrate portions of the bottle that form no part of the claimed design.

1 Claim, 7 Drawing Sheets

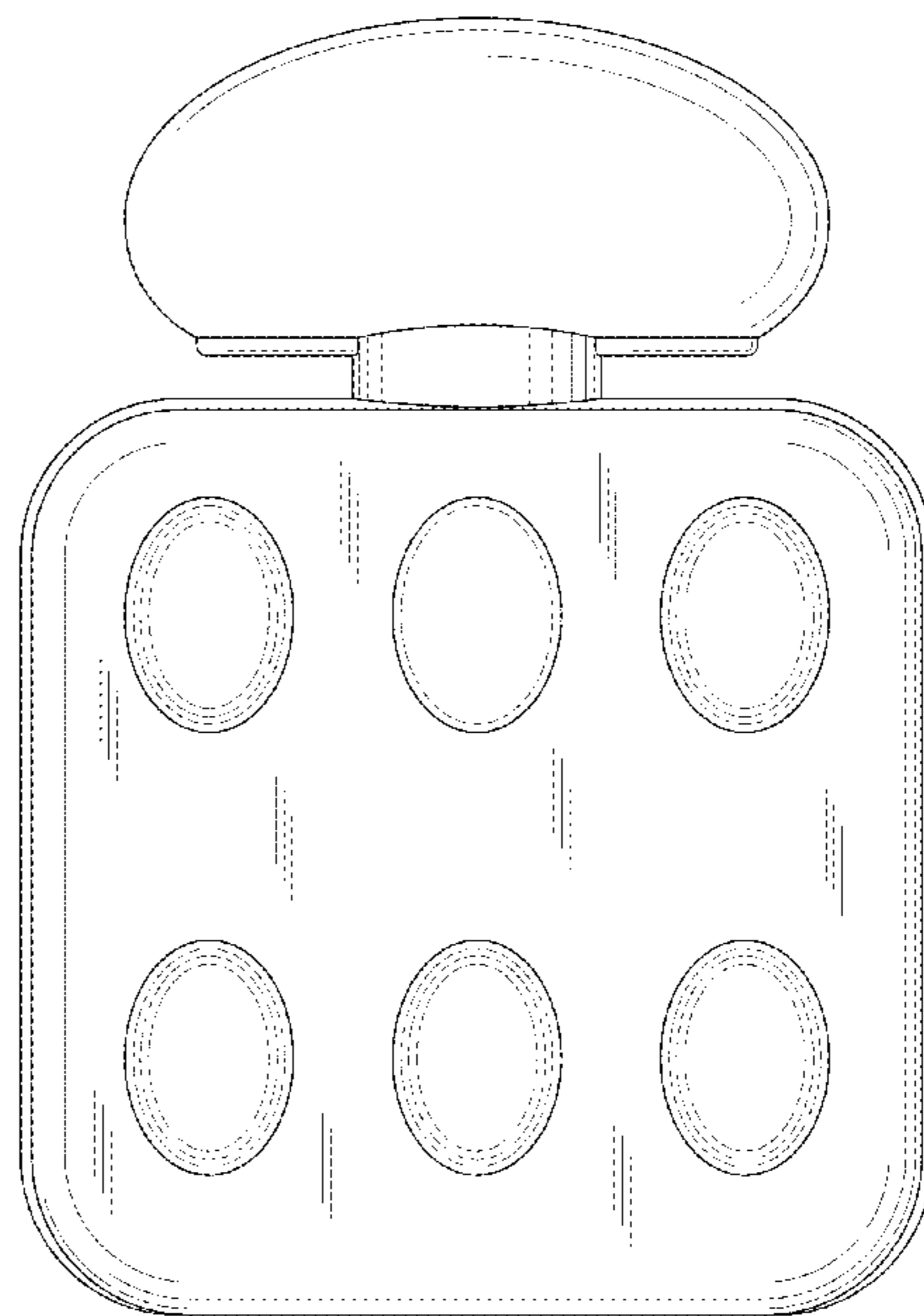
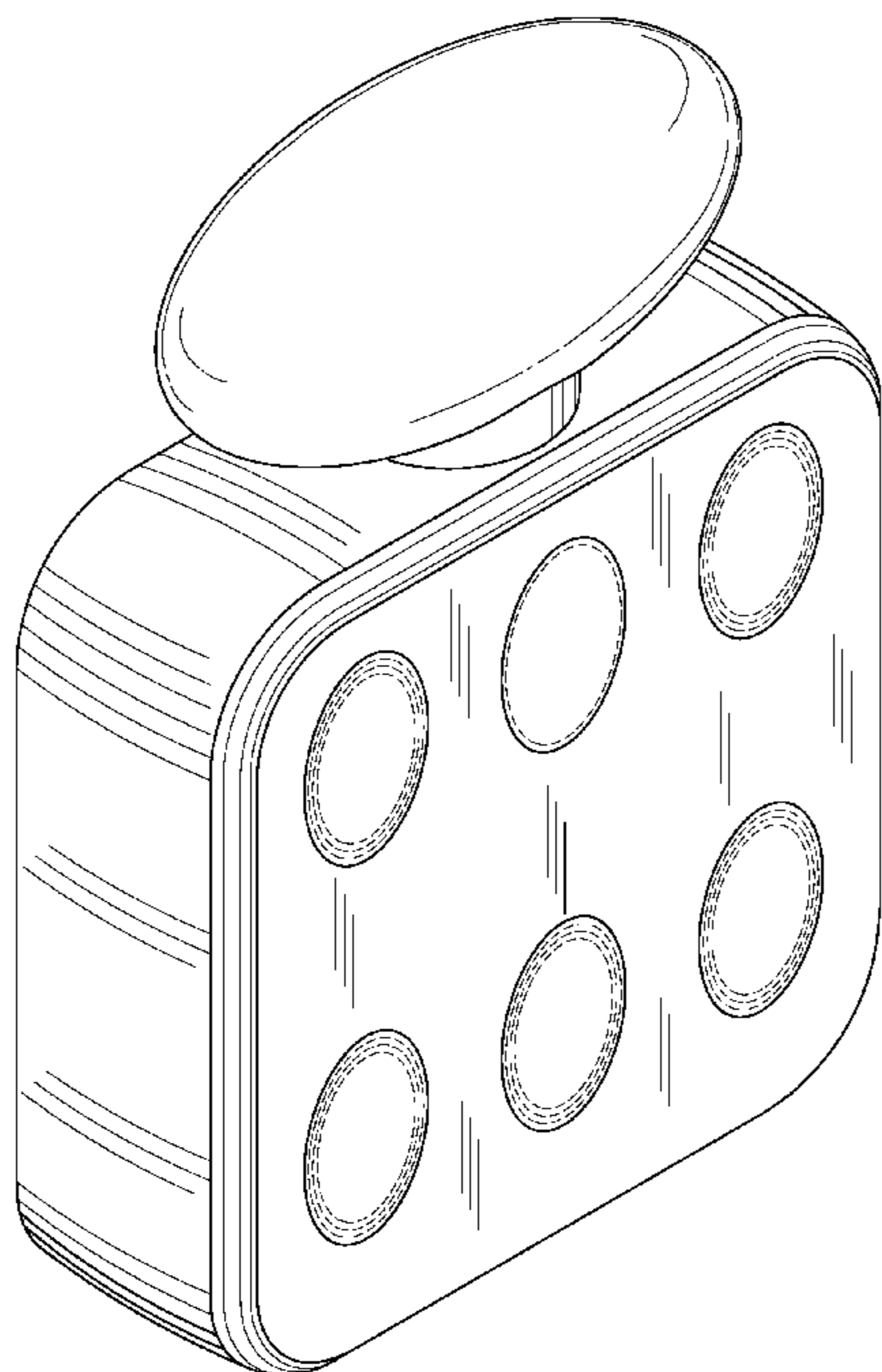

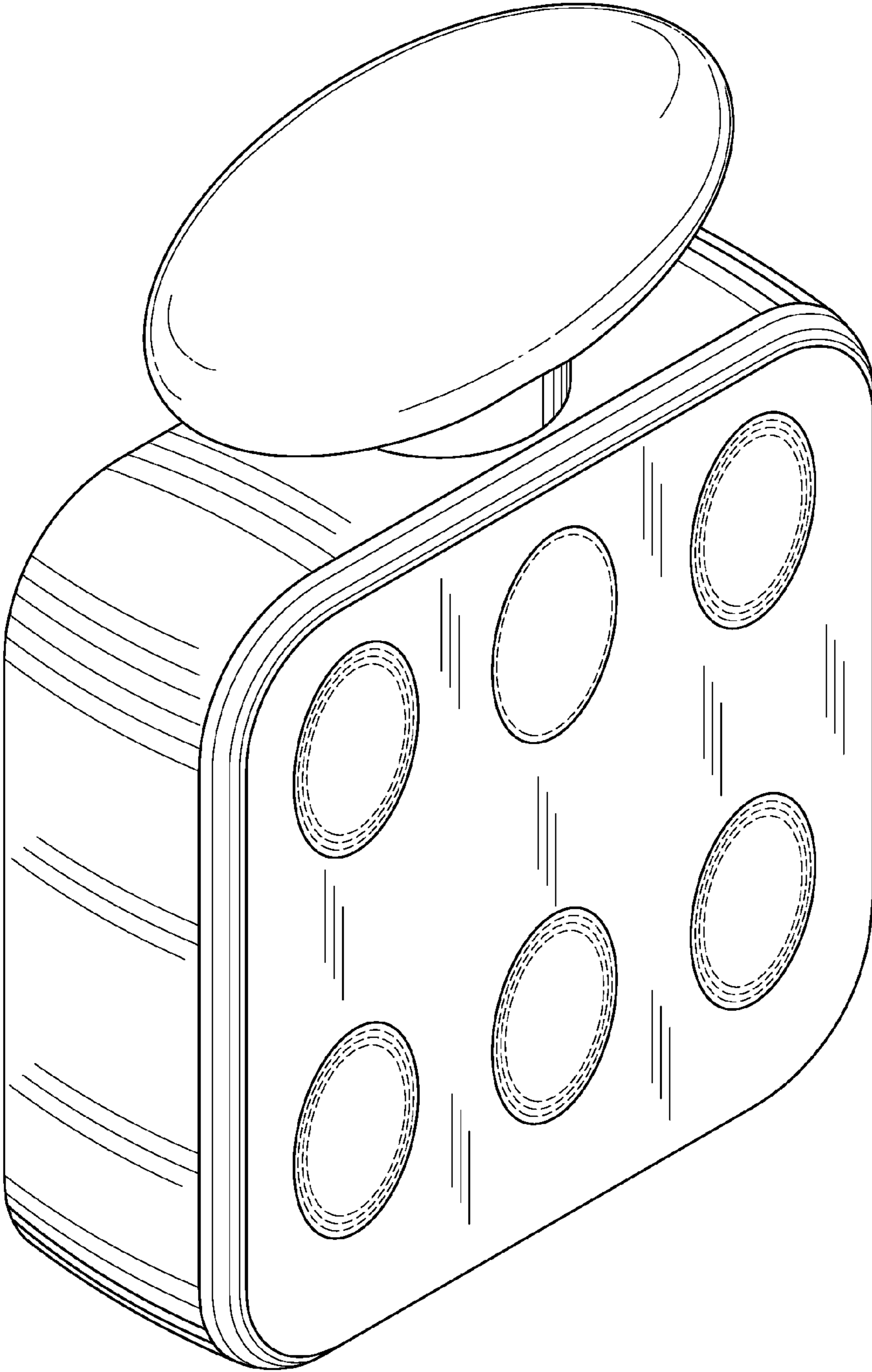

FIG. 1

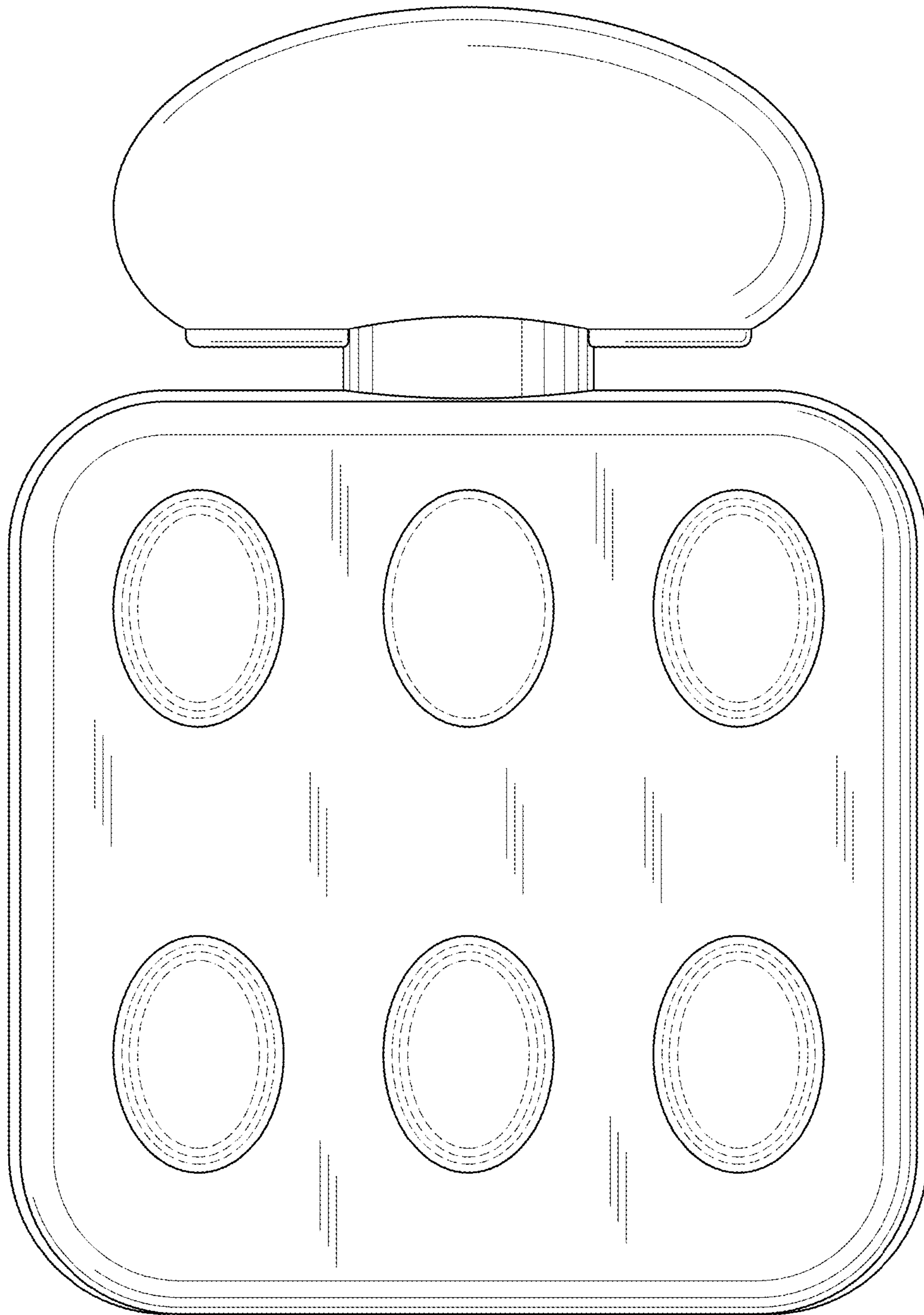

FIG. 2

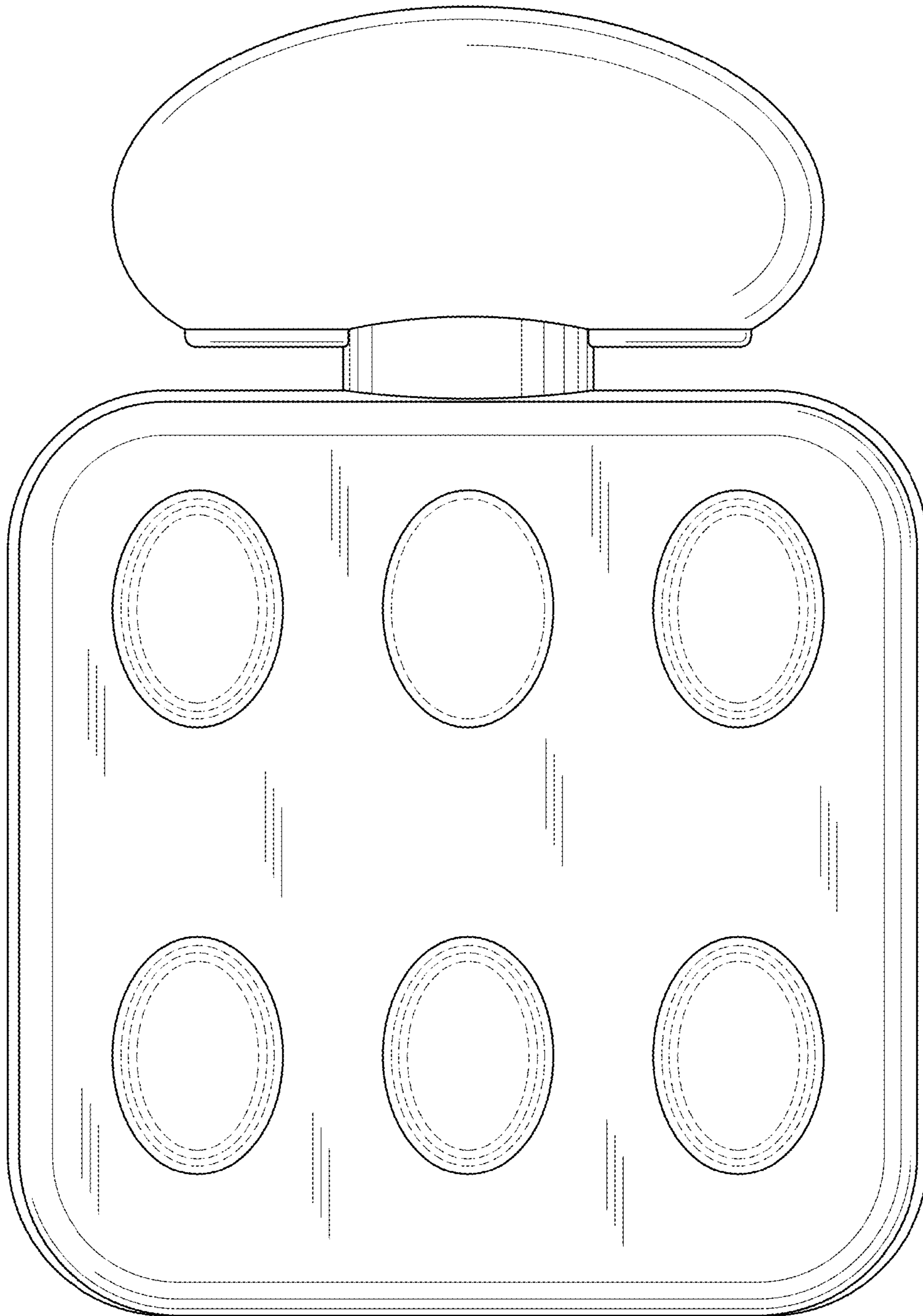

FIG. 3

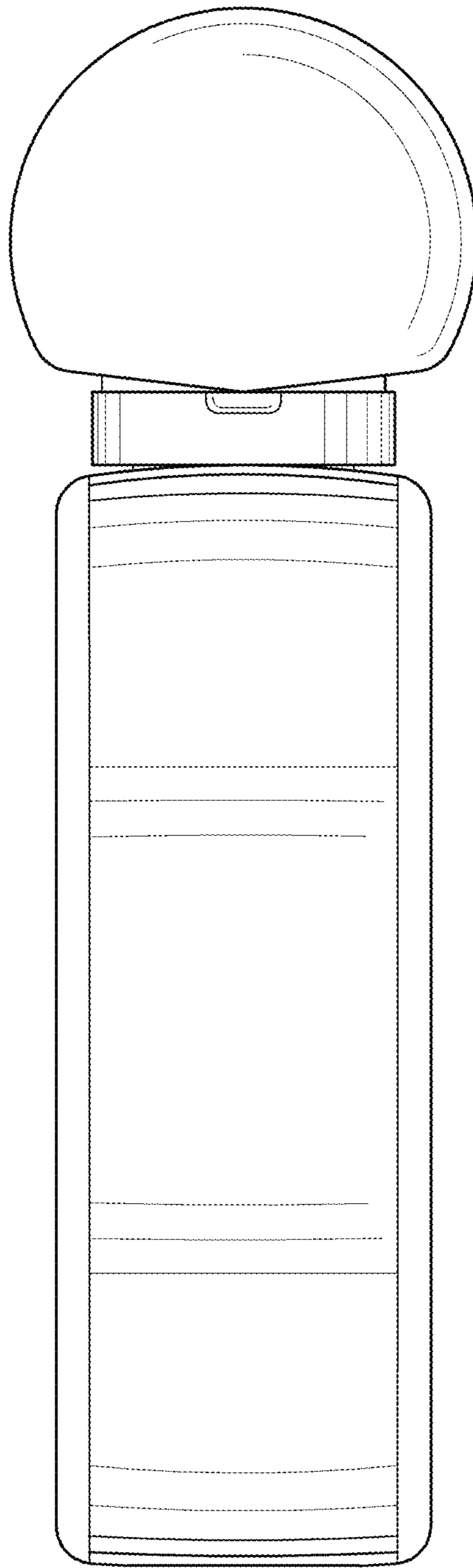

FIG.4

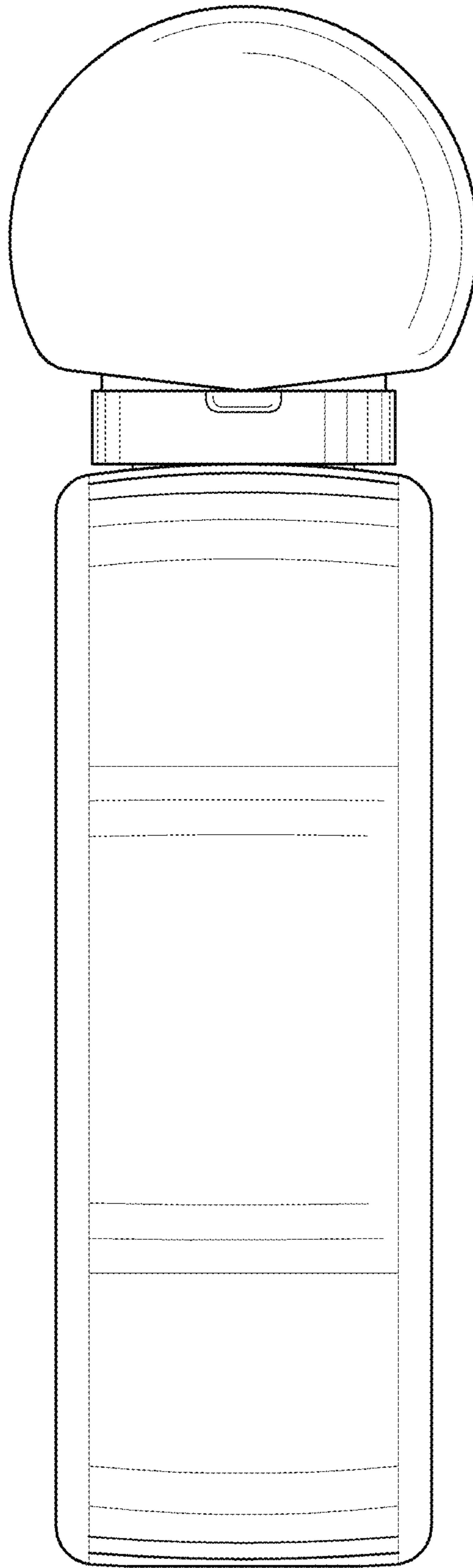

FIG. 5

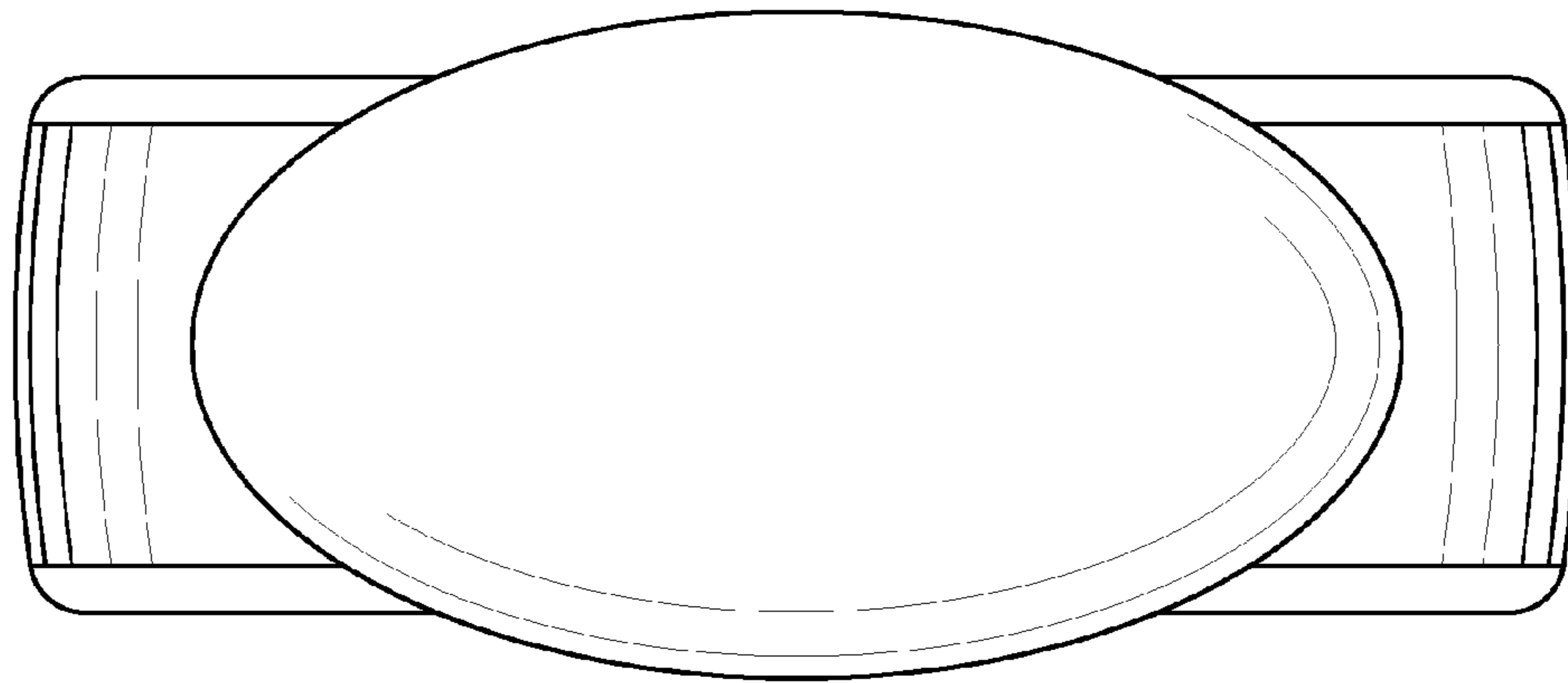

FIG.6

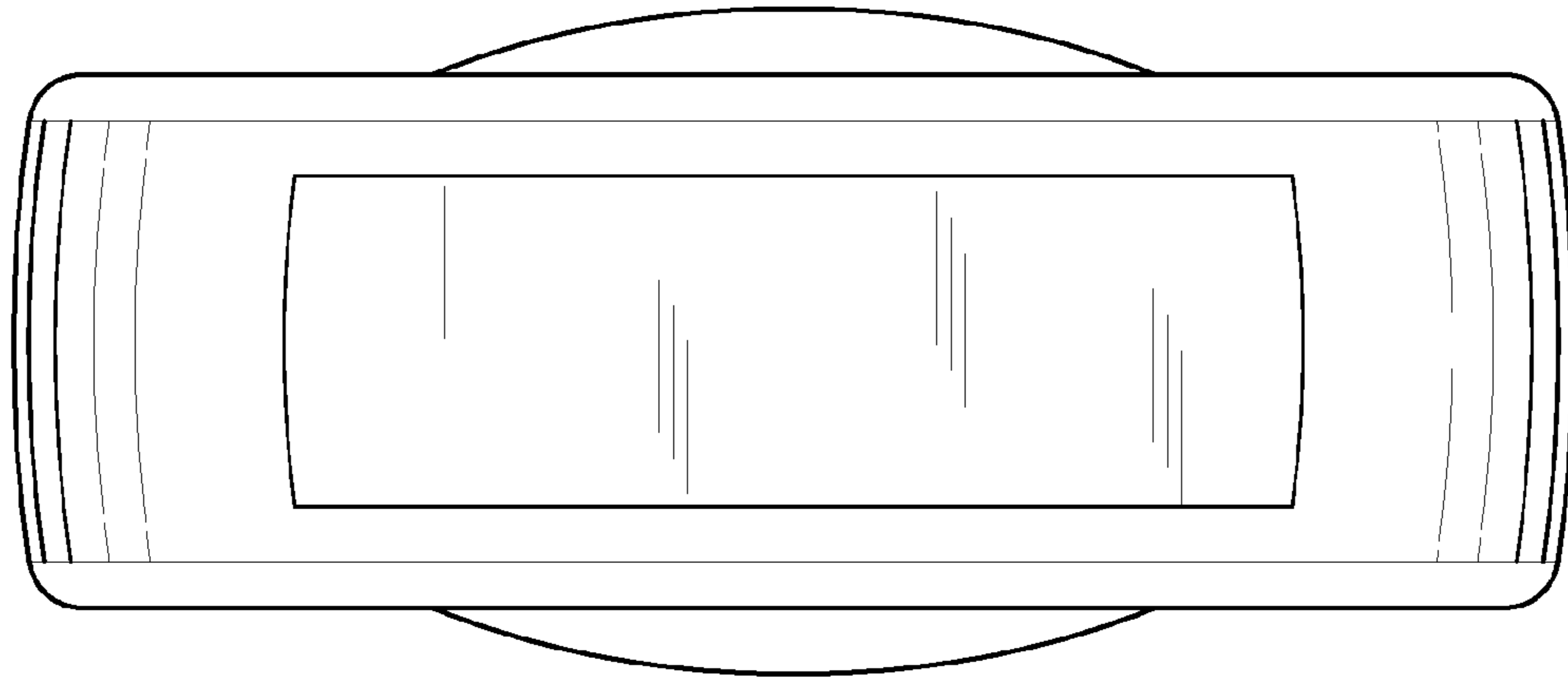

FIG.7