



US00D769468S

(12) **United States Design Patent** (10) **Patent No.:** **US D769,468 S**
Pope (45) **Date of Patent:** **** Oct. 18, 2016**

- (54) **TWO WING DIAMOND FOUNDATION**
- (71) Applicant: **New Generation Steel Foundations, LLC, Carnegie, PA (US)**
- (72) Inventor: **Michael M. Pope, Carnegie, PA (US)**
- (73) Assignee: **New Generation Steel Foundations, LLC, Carnegie, PA (US)**
- (**) Term: **15 Years**
- (21) Appl. No.: **29/548,795**
- (22) Filed: **Dec. 16, 2015**

Related U.S. Application Data

- (63) Continuation-in-part of application No. 14/683,479, filed on Apr. 10, 2015.
- (51) **LOC (10) Cl.** **25-01**
- (52) **U.S. Cl.**
USPC **D25/128**
- (58) **Field of Classification Search**
USPC D25/126-135; 52/25, 29, 51, 167.4,
52/169.8, 169.9, 274
See application file for complete search history.

References Cited

U.S. PATENT DOCUMENTS

D26,842 S *	3/1897	Hwaler	D25/128
D195,831 S *	8/1963	Waldman	D25/128
D218,582 S *	9/1970	Kiester	135/118
D223,395 S *	4/1972	Selden	D25/128
D233,671 S *	11/1974	Gay	D25/126
D259,443 S *	6/1981	James	D25/128
D282,104 S *	1/1986	Taylor	D25/131
D394,564 S *	5/1998	Haney	D25/126
D454,403 S *	3/2002	Naccarato	D25/128
D504,183 S *	4/2005	McCracken	D25/126
D600,366 S *	9/2009	Boardman	D25/133
D616,115 S *	5/2010	Clayton	D25/126

D695,424 S * 12/2013 Dionne D25/126

* cited by examiner

Primary Examiner — Garth Rademaker

Assistant Examiner — Samantha Q Lawrence

(74) *Attorney, Agent, or Firm* — H.C. Park & Associates, PLC

(57) **CLAIM**

The ornamental design for a two wing diamond foundation, as shown and described.

DESCRIPTION

FIG. 1 is a front perspective view of a two wing diamond foundation according to an exemplary embodiment of the present invention.

FIG. 2 is a rear perspective view of the two wing diamond foundation of FIG. 1.

FIG. 3 is a front view thereof.

FIG. 4 is a rear view thereof.

FIG. 5 is a left side view thereof.

FIG. 6 is a right side view thereof.

FIG. 7 is a top plan view thereof.

FIG. 8 is a bottom plan view thereof.

FIG. 9 is a front perspective view of a two wing diamond foundation according to a second exemplary embodiment of the present invention.

FIG. 10 is a rear perspective view of the two wing diamond foundation of FIG. 9.

FIG. 11 is a front perspective view of a two wing diamond foundation according to a third exemplary embodiment of the present invention; and,

FIG. 12 is a rear perspective view of the two wing diamond foundation of FIG. 11.

The broken lines shown in FIGS. 9-12 illustrate portions of the two wing diamond foundation that form no part of the claimed design.

1 Claim, 6 Drawing Sheets

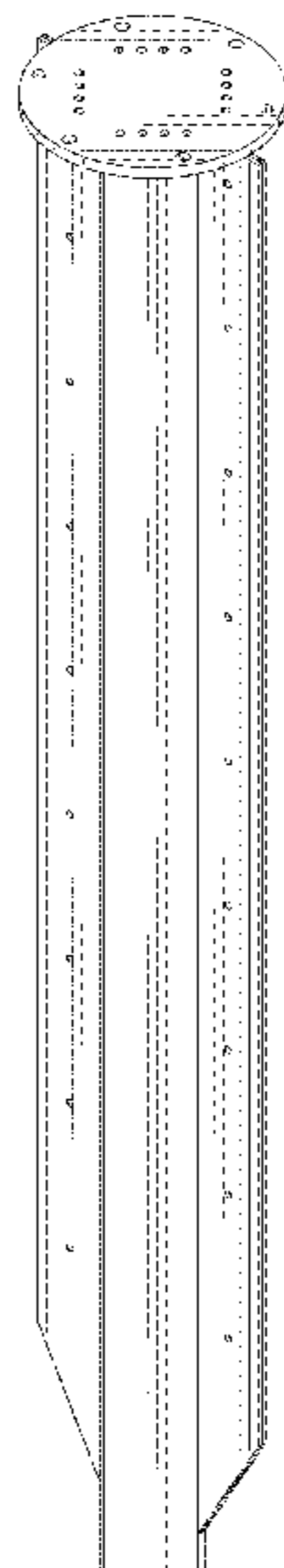

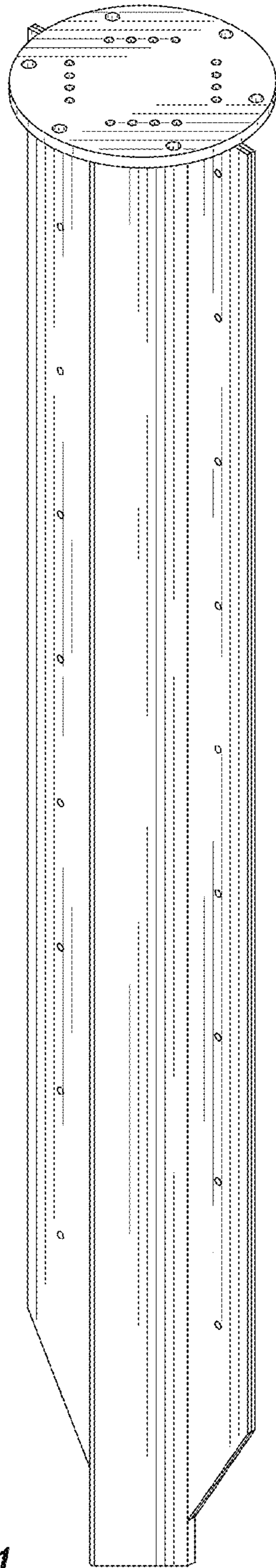

FIG. 1

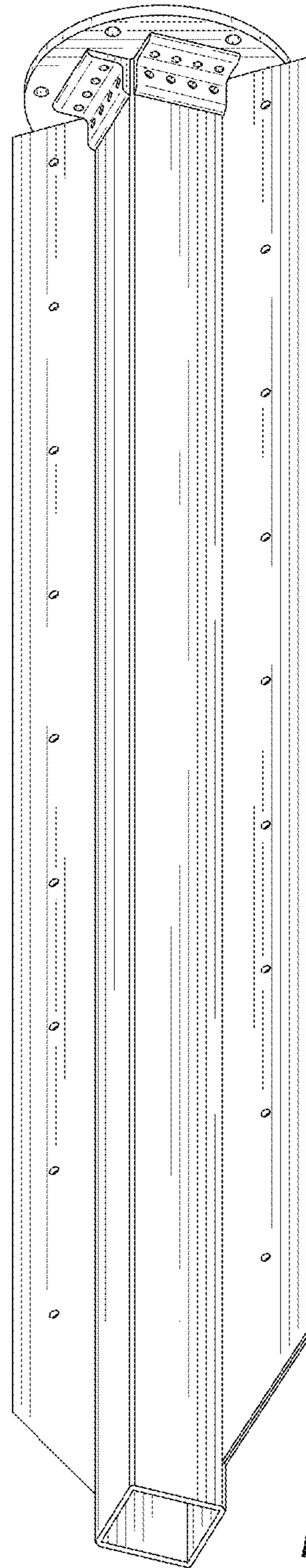

FIG. 2

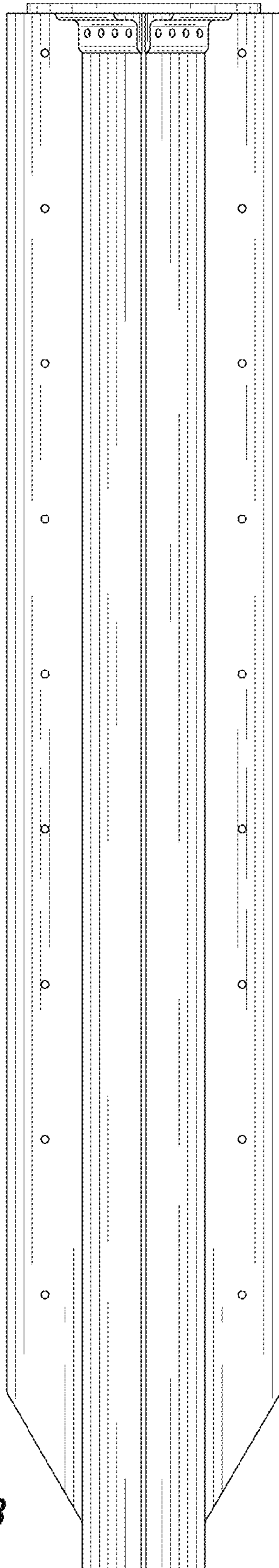

FIG. 3

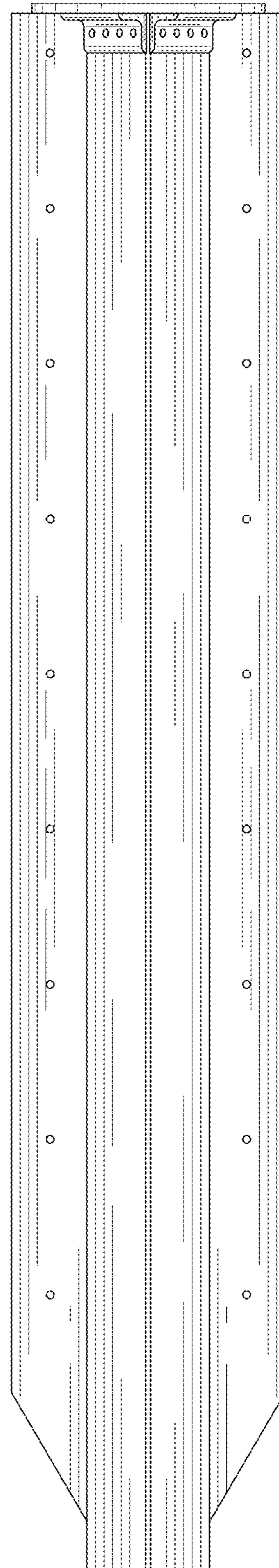

FIG. 4

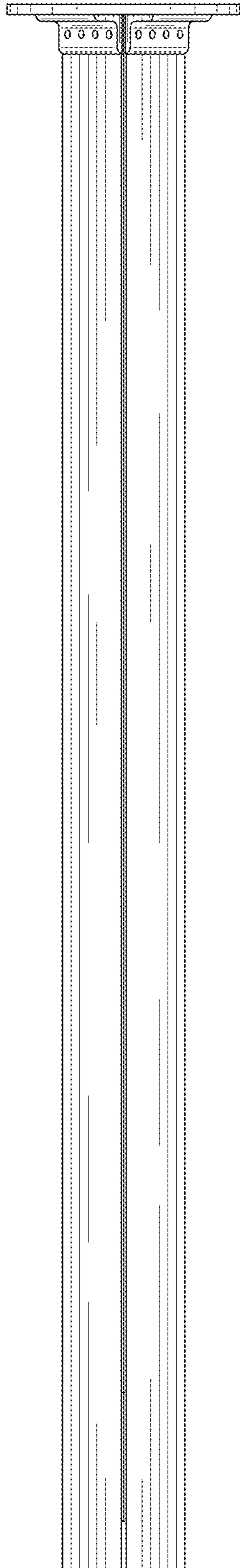

FIG. 5

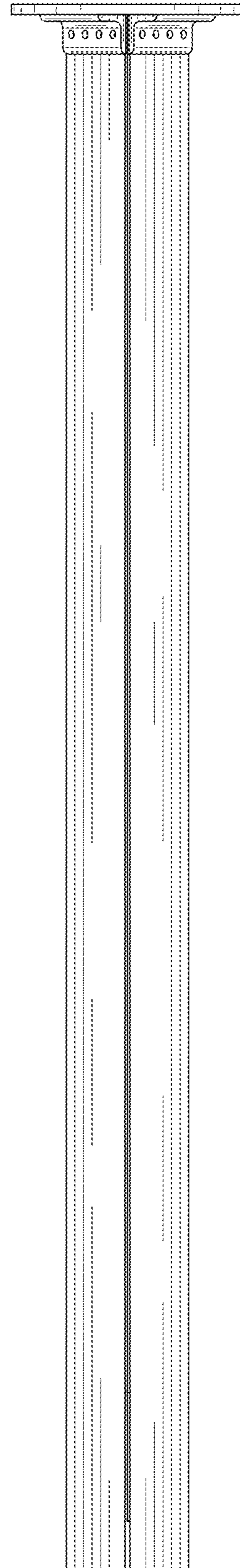

FIG. 6

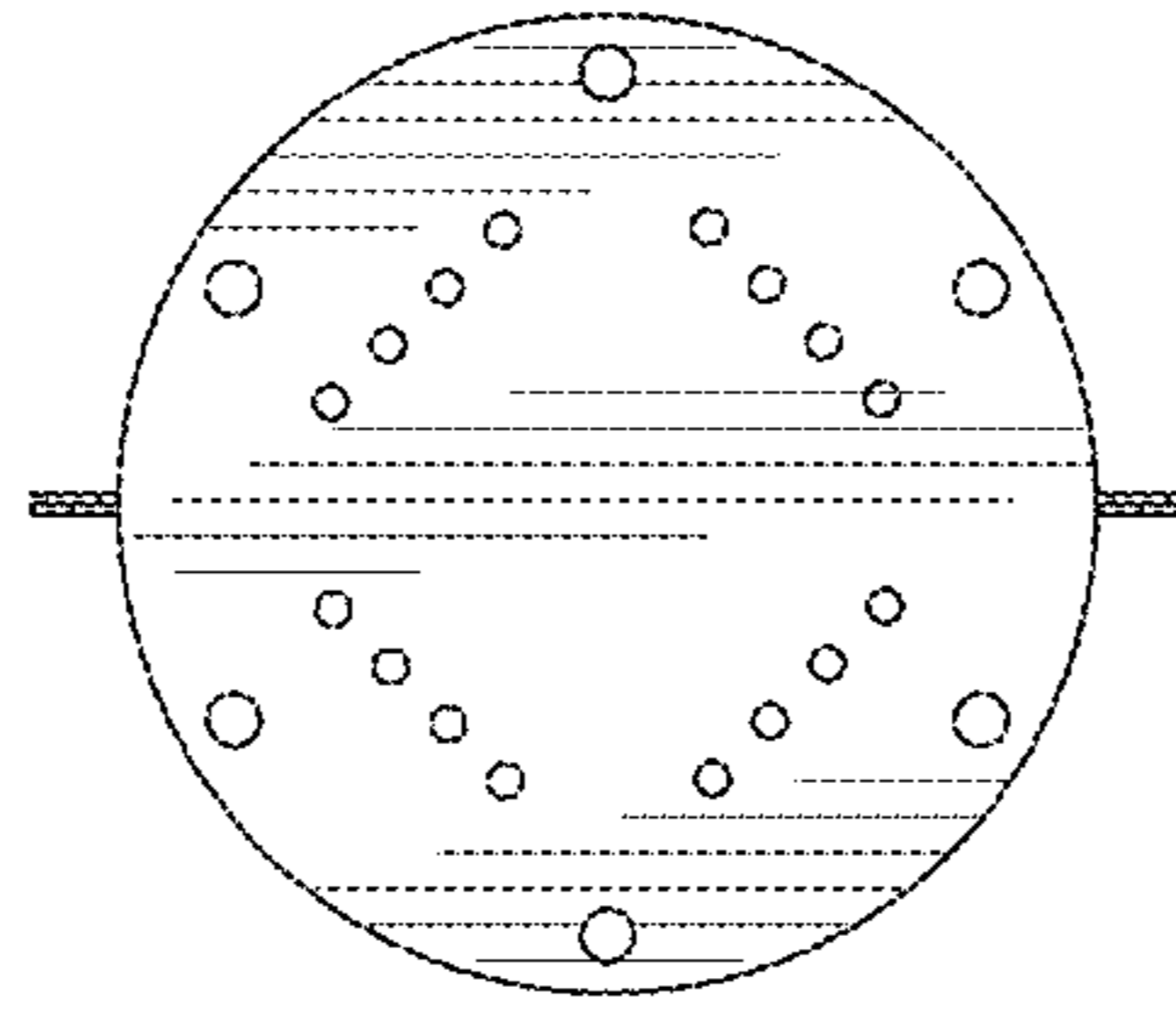

FIG. 7

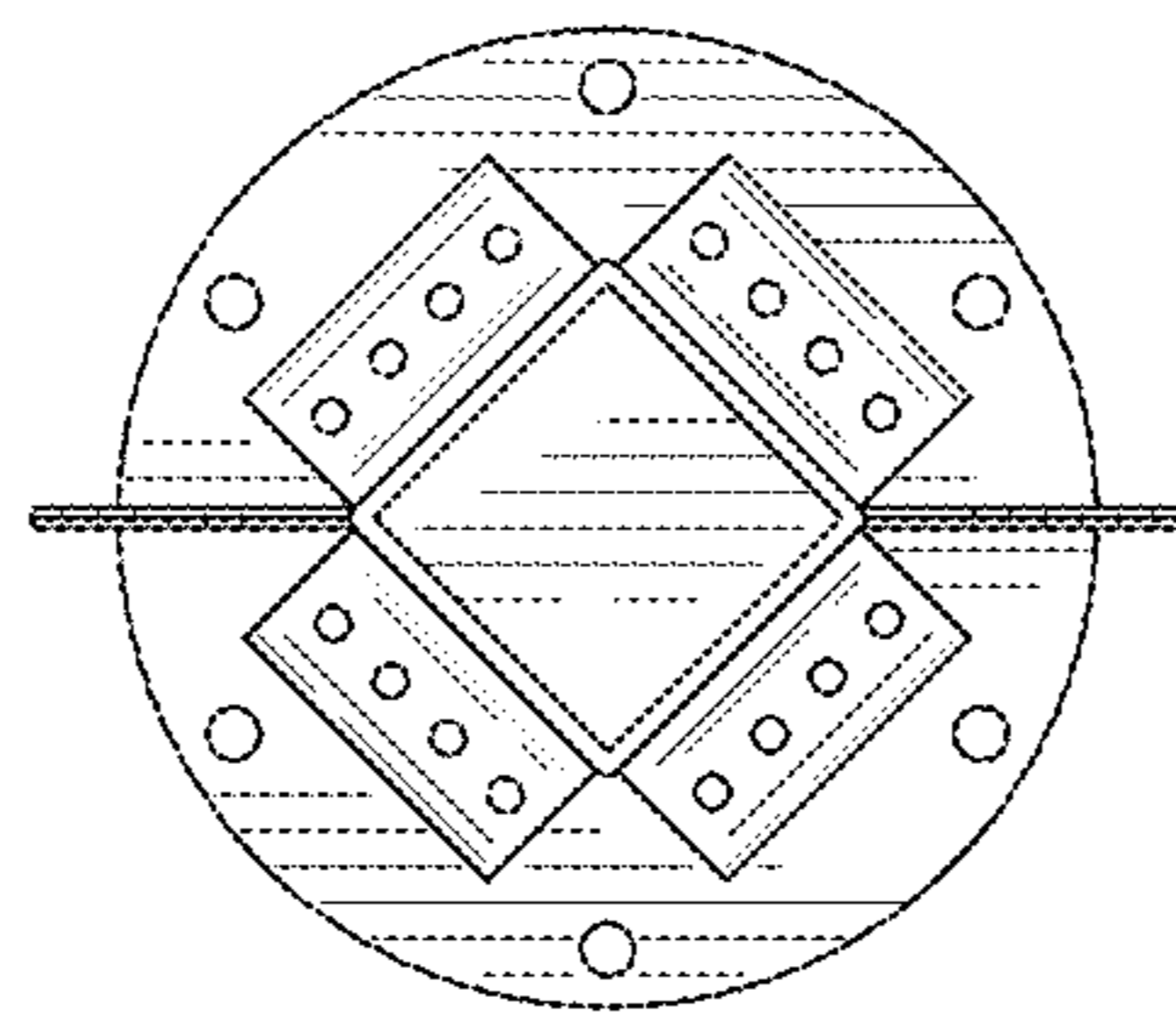

FIG. 8

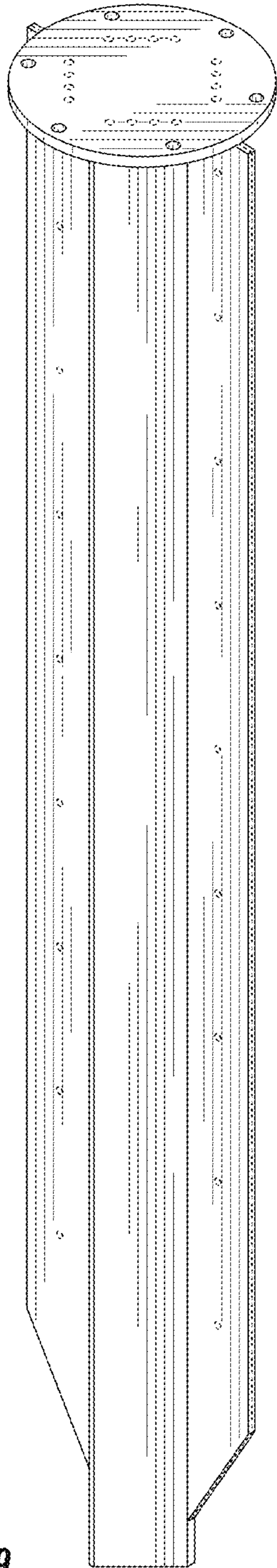

FIG. 9

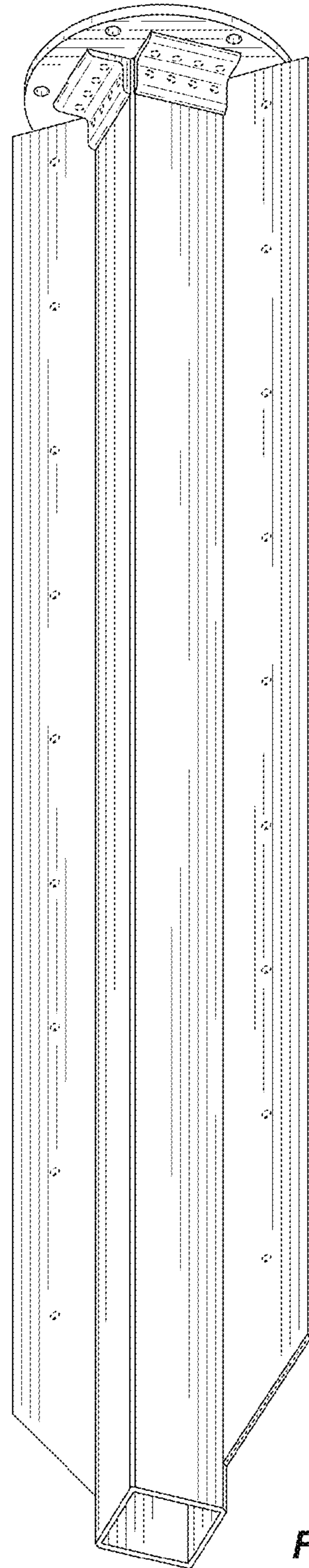

FIG. 10

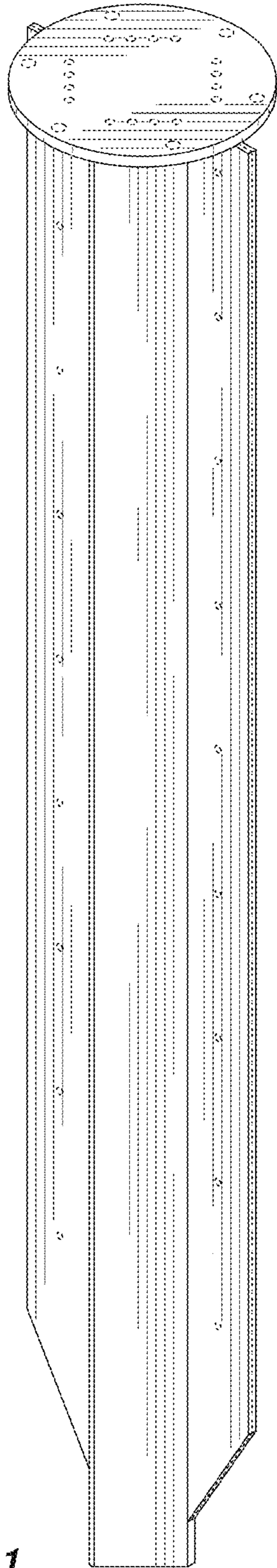

FIG. 11

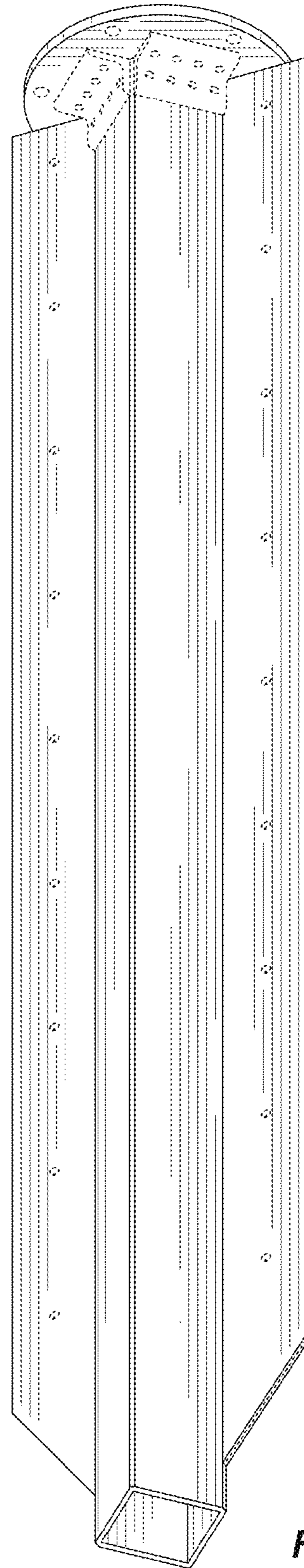

FIG. 12