

US00D769444S

(12) **United States Design Patent** (10) **Patent No.:** **US D769,444 S**
Mosler et al. (45) **Date of Patent:** **** Oct. 18, 2016**

(54) **ADAPTER DEVICE**
(75) Inventors: **Theodore J. Mosler**, Raleigh, NC
(US); **David L. Foshee**, Apex, NC (US)

5,211,638 A 5/1993 Dudar et al.
5,232,029 A 8/1993 Knox et al.
5,257,650 A 11/1993 Fisk et al.

(Continued)

(73) Assignee: **YUKON MEDICAL, LLC**, Durham,
NC (US)

FOREIGN PATENT DOCUMENTS

EP 0 570 939 B1 11/1993
EP 0 521 460 B1 9/1995

(Continued)

(**) Term: **14 Years**

(21) Appl. No.: **29/425,955**

(22) Filed: **Jun. 28, 2012**

(51) **LOC (10) Cl.** **24-02**

(52) **U.S. Cl.**
USPC **D24/130**

(58) **Field of Classification Search**
USPC D24/112, 129, 130, 224, 231, 108;
604/412, 406, 411, 405, 414, 519, 520,
604/410, 87; 141/329, 330, 383, 386
CPC A61J 1/2096; A61J 2001/201; A61J
2001/2075; A61J 2001/2082; A61J
2001/2055; A61M 5/162
See application file for complete search history.

OTHER PUBLICATIONS

The International Bureau of WIPO, International Preliminary report
on Patentability and Writing Opinion for International Application
No. PCT/US2009/039215, dated Oct. 5, 2010.

(Continued)

Primary Examiner — Ian Simmons
Assistant Examiner — Ieisha Price
(74) *Attorney, Agent, or Firm* — Christopher J. Knors;
Moore & Van Allen PLLC

(57) **CLAIM**

The ornamental design for an adapter device, as shown and
described.

(56) **References Cited**

U.S. PATENT DOCUMENTS

2,584,397 A 2/1952 Pitman
4,175,559 A 11/1979 Kreb
4,328,802 A 5/1982 Curley et al.
D270,568 S 9/1983 Armstrong
4,729,401 A 3/1988 Raines
D296,592 S 7/1988 Wellenstam
4,759,756 A 7/1988 Forman et al.
D302,729 S 8/1989 Stephens et al.
4,863,454 A 9/1989 LaBove
4,921,490 A 5/1990 Spier et al.
4,994,029 A 2/1991 Rohrbough
4,997,430 A 3/1991 Van Der Heiden et al.
5,088,996 A 2/1992 Kopfer et al.
5,152,965 A 10/1992 Fisk et al.

DESCRIPTION

FIG. 1 is a first side view showing an adapter device in
accordance with our new design;
FIG. 2 is a second side view thereof, the view rotated 90
degrees relative to the first side view;
FIG. 3 is a third side view thereof, the view rotated 180
degrees relative to the first side view;
FIG. 4 is a fourth side view thereof, the view rotated 270
degrees relative to the first side view;
FIG. 5 is a top plan view thereof; and,
FIG. 6 is a bottom plan view thereof.
The broken lines in the drawings illustrate portions of the
adapter device and form no part of the claimed design.

1 Claim, 6 Drawing Sheets

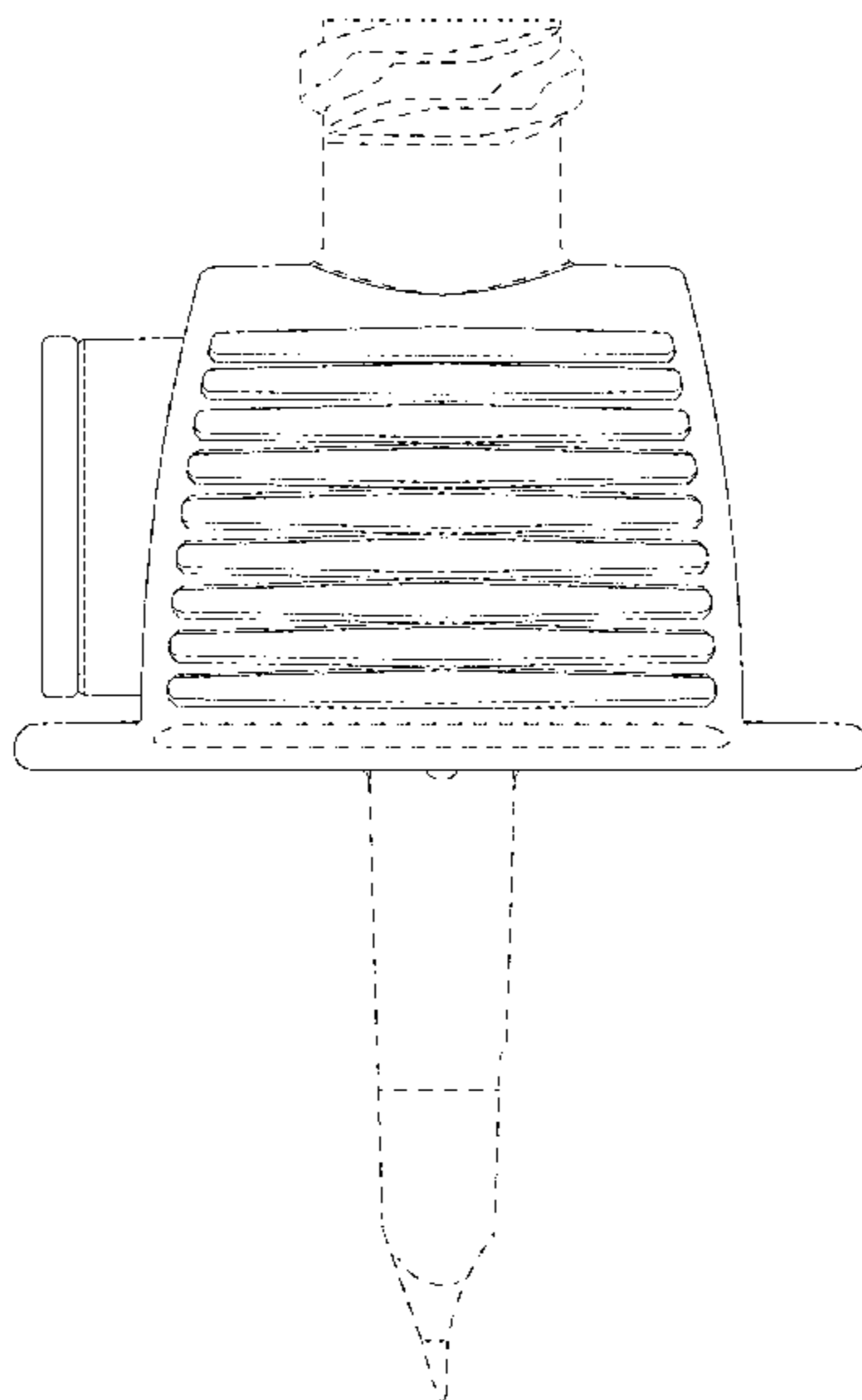

(56)

References Cited

U.S. PATENT DOCUMENTS

5,279,576 A	1/1994	Loo et al.	6,610,040 B1	8/2003	Fowles et al.
5,297,433 A	3/1994	Elgas	D481,125 S	10/2003	Hayamizu
5,304,163 A	4/1994	Bonnici et al.	6,638,244 B1	10/2003	Reynolds
5,304,165 A	4/1994	Haber et al.	6,645,171 B1	11/2003	Robinson et al.
5,329,976 A	7/1994	Haber et al.	6,645,179 B1	11/2003	Ishikawa et al.
5,334,163 A	8/1994	Sinnett	6,656,433 B2	12/2003	Sasso
5,352,191 A	10/1994	Sunago et al.	6,663,593 B2	12/2003	Ito
5,423,753 A	6/1995	Fowles et al.	6,666,852 B2	12/2003	Niedospial
D360,030 S	7/1995	Michels et al.	6,699,229 B2	3/2004	Zinger et al.
5,445,631 A	8/1995	Uchida	6,719,719 B2	4/2004	Carmel et al.
D363,541 S	10/1995	Cottone et al.	6,752,180 B2	6/2004	Delay
5,464,123 A	11/1995	Scarrow	6,817,987 B2	11/2004	Vetter et al.
5,466,220 A	11/1995	Brenneman	6,832,994 B2	12/2004	Niedospial et al.
5,520,659 A	5/1996	Hedges	6,852,103 B2	2/2005	Fuller et al.
5,522,804 A	6/1996	Lynn	6,875,203 B1	4/2005	Fowles et al.
5,526,853 A	6/1996	McPhee et al.	6,875,205 B2	4/2005	Leinsing
5,527,306 A	6/1996	Haining	6,890,328 B2	5/2005	Fowles et al.
5,554,128 A	9/1996	Hedges	D506,256 S	6/2005	Miyoshi et al.
5,599,302 A	2/1997	Lilley et al.	6,901,975 B2	6/2005	Aramata et al.
5,623,969 A *	4/1997	Raines 137/854	6,948,522 B2	9/2005	Newbrough et al.
5,636,660 A	6/1997	Pfleiderer et al.	6,994,315 B2	2/2006	Ryan et al.
5,641,010 A	6/1997	Maier	6,997,917 B2	2/2006	Niedospial et al.
5,685,845 A	11/1997	Grimard	D523,956 S *	6/2006	Guala D24/108
D393,722 S *	4/1998	Fangrow et al. D24/112	7,074,216 B2	7/2006	Fowles et al.
5,743,312 A	4/1998	Pfeifer et al.	7,077,835 B2	7/2006	Robinson et al.
5,766,147 A	6/1998	Sancoff et al.	7,140,401 B2	11/2006	Wilcox et al.
5,776,124 A	7/1998	Wald	7,261,698 B2	8/2007	Sampson et al.
5,785,701 A	7/1998	Sams et al.	7,294,122 B2	11/2007	Kubo et al.
5,833,213 A	11/1998	Ryan	D561,348 S	2/2008	Zinger et al.
5,833,674 A	11/1998	Turnbull et al.	7,326,194 B2	2/2008	Zinger et al.
5,846,233 A	12/1998	Lilley et al.	7,358,505 B2	4/2008	Woodworth et al.
5,873,872 A	2/1999	Thibault et al.	D570,477 S	6/2008	Gallogly et al.
5,879,337 A	3/1999	Kuracina et al.	D571,006 S	6/2008	Baxter et al.
5,890,610 A	4/1999	Jansen et al.	D571,464 S	6/2008	Baxter et al.
5,989,237 A	11/1999	Fowles et al.	D572,820 S	7/2008	Gallogly et al.
6,019,750 A	2/2000	Fowles et al.	D574,491 S	8/2008	Baxter et al.
6,021,824 A	2/2000	Larsen et al.	D577,438 S	9/2008	Gallogly et al.
6,022,339 A	2/2000	Fowles et al.	D577,822 S	9/2008	Gallogly et al.
6,063,068 A	5/2000	Fowles et al.	7,425,209 B2	9/2008	Fowles et al.
D427,308 S	6/2000	Zinger	7,442,189 B2	10/2008	Curutcharry
6,071,270 A	6/2000	Fowles et al.	D582,033 S	12/2008	Baxter et al.
6,090,092 A	7/2000	Fowles et al.	D582,550 S	12/2008	Baxter et al.
6,113,571 A	9/2000	Zinger et al.	7,491,197 B2	2/2009	Jansen et al.
6,113,583 A	9/2000	Fowles et al.	7,507,227 B2	3/2009	Fangrow
6,139,534 A	10/2000	Niedospial et al.	7,510,548 B2	3/2009	Fangrow
6,146,362 A	11/2000	Turnbull et al.	D594,981 S *	6/2009	Bierman et al. D24/130
6,149,623 A	11/2000	Reynolds	7,632,261 B2	12/2009	Zinger et al.
6,159,192 A	12/2000	Fowles et al.	D616,984 S	6/2010	Gilboa
D437,052 S	1/2001	Newsom	7,743,799 B2	6/2010	Mosler et al.
6,168,037 B1	1/2001	Grimard	D620,591 S *	7/2010	Young D24/130
6,209,738 B1	4/2001	Jansen et al.	D630,732 S	1/2011	Lev et al.
6,237,649 B1	5/2001	Moisio et al.	D655,017 S	2/2012	Mosler et al.
6,238,372 B1	5/2001	Zinger et al.	2001/0021820 A1	9/2001	Lynn
D445,501 S	7/2001	Niedospial	2002/0066715 A1	6/2002	Niedospial
6,269,976 B1	8/2001	DeJonge	2002/0087118 A1	7/2002	Reynolds et al.
6,343,629 B1	2/2002	Wessman et al.	2002/0087144 A1	7/2002	Zinger et al.
6,355,023 B1	3/2002	Roth et al.	2002/0095121 A1	7/2002	Norton et al.
6,364,865 B1	4/2002	Lavi et al.	2002/0115980 A1	8/2002	Niedospial et al.
6,379,340 B1	4/2002	Zinger et al.	2002/0124905 A1	9/2002	Draughn et al.
6,409,708 B1	6/2002	Wessman	2003/0032935 A1	2/2003	Damiano et al.
6,453,956 B2	9/2002	Safabash	2003/0153895 A1	8/2003	Leinsing
6,474,375 B2	11/2002	Spero et al.	2003/0199846 A1	10/2003	Fowles et al.
6,475,183 B1	11/2002	Epstein et al.	2004/0024354 A1	2/2004	Reynolds
D468,015 S	12/2002	Horppu	2004/0044327 A1 *	3/2004	Hasegawa 604/414
D468,016 S	12/2002	Mosler et al.	2004/0073189 A1	4/2004	Wyatt et al.
6,503,240 B1	1/2003	Niedospial et al.	2004/0112457 A1	6/2004	Norton et al.
D472,316 S	3/2003	Douglas et al.	2004/0115099 A1	6/2004	Smith
D472,630 S	4/2003	Douglas et al.	2004/0199139 A1	10/2004	Fowles et al.
D473,305 S	4/2003	Halseth	2004/0210207 A1	10/2004	Amisar et al.
6,544,246 B1	4/2003	Niedospial	2004/0249341 A1	12/2004	Newbrough et al.
6,551,299 B2	4/2003	Miyoshi et al.	2005/0124964 A1	6/2005	Niedospial et al.
6,558,365 B2	5/2003	Zinger et al.	2005/0137523 A1	6/2005	Wyatt et al.
6,571,837 B2	6/2003	Jansen et al.	2005/0137566 A1	6/2005	Fowles et al.
6,582,415 B1	6/2003	Fowles et al.	2005/0148994 A1	7/2005	Leinsing
6,598,765 B2	7/2003	Pagel et al.	2005/0151105 A1	7/2005	Ryan et al.
			2006/0025747 A1	2/2006	Sullivan et al.
			2006/0026482 A1	2/2006	Fujisaki
			2006/0030832 A1	2/2006	Niedospial et al.
			2006/0040340 A1	2/2006	Greene

(56)

References Cited

U.S. PATENT DOCUMENTS

2006/0089594 A1 4/2006 Landau
 2006/0155257 A1 7/2006 Reynolds
 2006/0184103 A1 8/2006 Paproski et al.
 2007/0032775 A1 2/2007 Niedoşpial et al.
 2007/0060904 A1 3/2007 Vedrine et al.
 2007/0079894 A1 4/2007 Kraus et al.
 2007/0088252 A1 4/2007 Pestotnik et al.
 2007/0088313 A1 4/2007 Zinger et al.
 2007/0156112 A1 7/2007 Walsh
 2007/0167904 A1 7/2007 Zinger et al.
 2007/0270778 A9 11/2007 Zinger et al.
 2008/0009789 A1 1/2008 Zinger et al.
 2008/0021381 A1 1/2008 Lurvey et al.
 2008/0132851 A1 6/2008 Shaw et al.
 2008/0140021 A1 6/2008 Richmond
 2008/0172024 A1 7/2008 Yow
 2008/0249479 A1 10/2008 Zinger et al.
 2008/0283741 A1 11/2008 Mukaibatake
 2009/0024096 A1 1/2009 Hai et al.
 2009/0054834 A1 2/2009 Zinger et al.
 2009/0062732 A1 3/2009 Radmer
 2009/0082734 A1 3/2009 Walters et al.
 2009/0082750 A1 3/2009 Denenburg et al.
 2009/0099547 A1 4/2009 Radmer
 2009/0177177 A1 7/2009 Zinger et al.
 2009/0198217 A1 8/2009 Thorne et al.
 2009/0204066 A1 8/2009 Radmer et al.
 2009/0216184 A1 8/2009 Radmer et al.

2009/0216212 A1* 8/2009 Fangrow, Jr. 604/406
 2009/0275895 A1 11/2009 Sie et al.
 2009/0299288 A1 12/2009 Sie et al.
 2010/0168664 A1 7/2010 Zinger et al.
 2010/0179506 A1 7/2010 Shemesh et al.
 2010/0198148 A1 8/2010 Zinger et al.
 2010/0228220 A1 9/2010 Zinger et al.
 2010/0241088 A1 9/2010 Ranalletta et al.
 2011/0022006 A1 1/2011 Walters et al.
 2012/0179129 A1* 7/2012 Imai 604/414
 2012/0220977 A1* 8/2012 Yow 604/405

FOREIGN PATENT DOCUMENTS

EP 0 814 866 B1 6/2001
 EP 1 192 966 B1 4/2002
 EP 0 737 484 B1 8/2002
 EP 0 815 886 B1 10/2003
 EP 1 145 702 B1 5/2010
 WO WO 96/29113 9/1996
 WO WO 97/20536 6/1997
 WO WO 01/49361 7/2001
 WO WO 2011/004360 1/2011

OTHER PUBLICATIONS

Japanese Intellectual Property Office, Japanese Office Action for Japanese Design Application No. 2012-002325 dated Jul. 20, 2012 (translation attached).

* cited by examiner

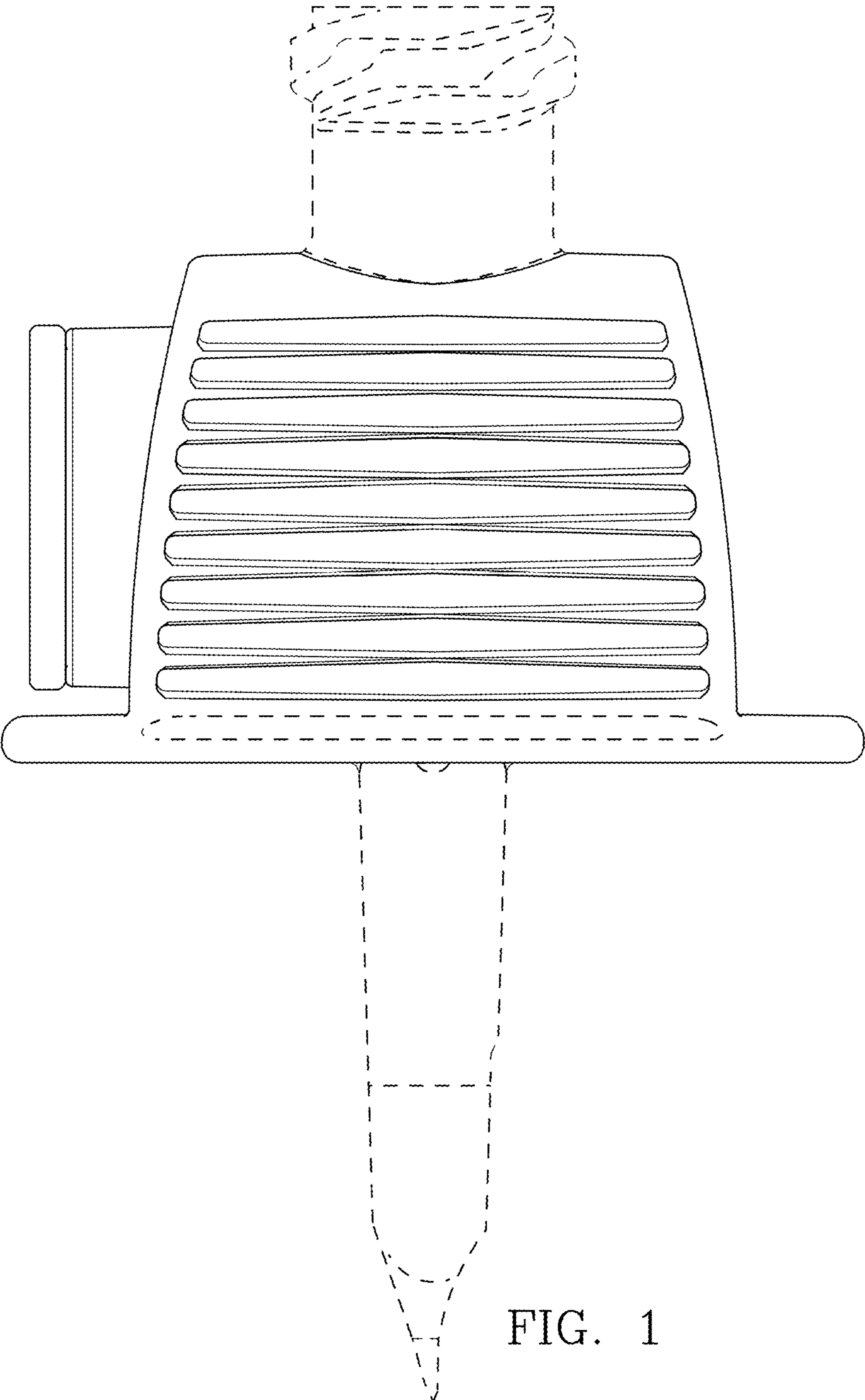

FIG. 1

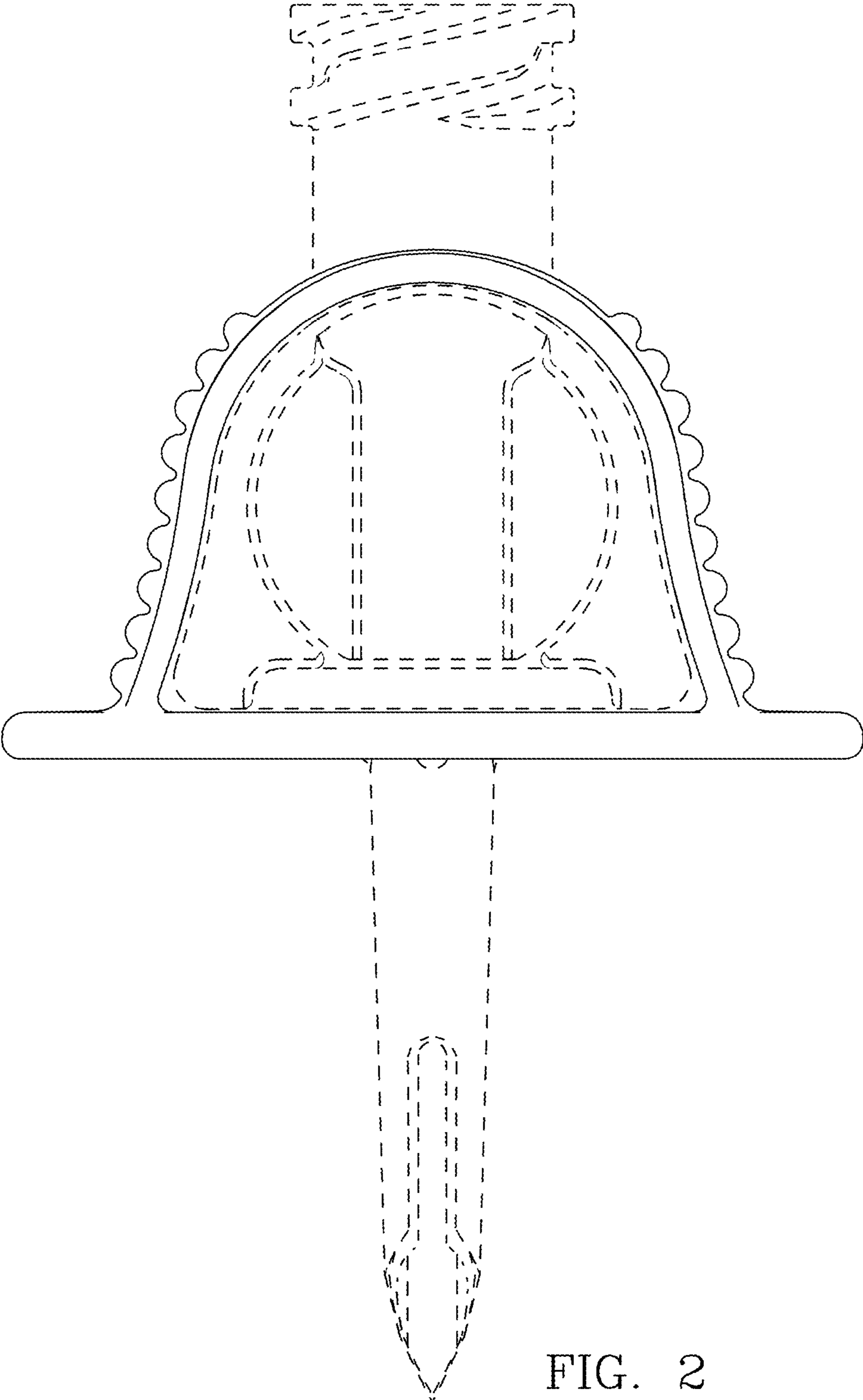

FIG. 2

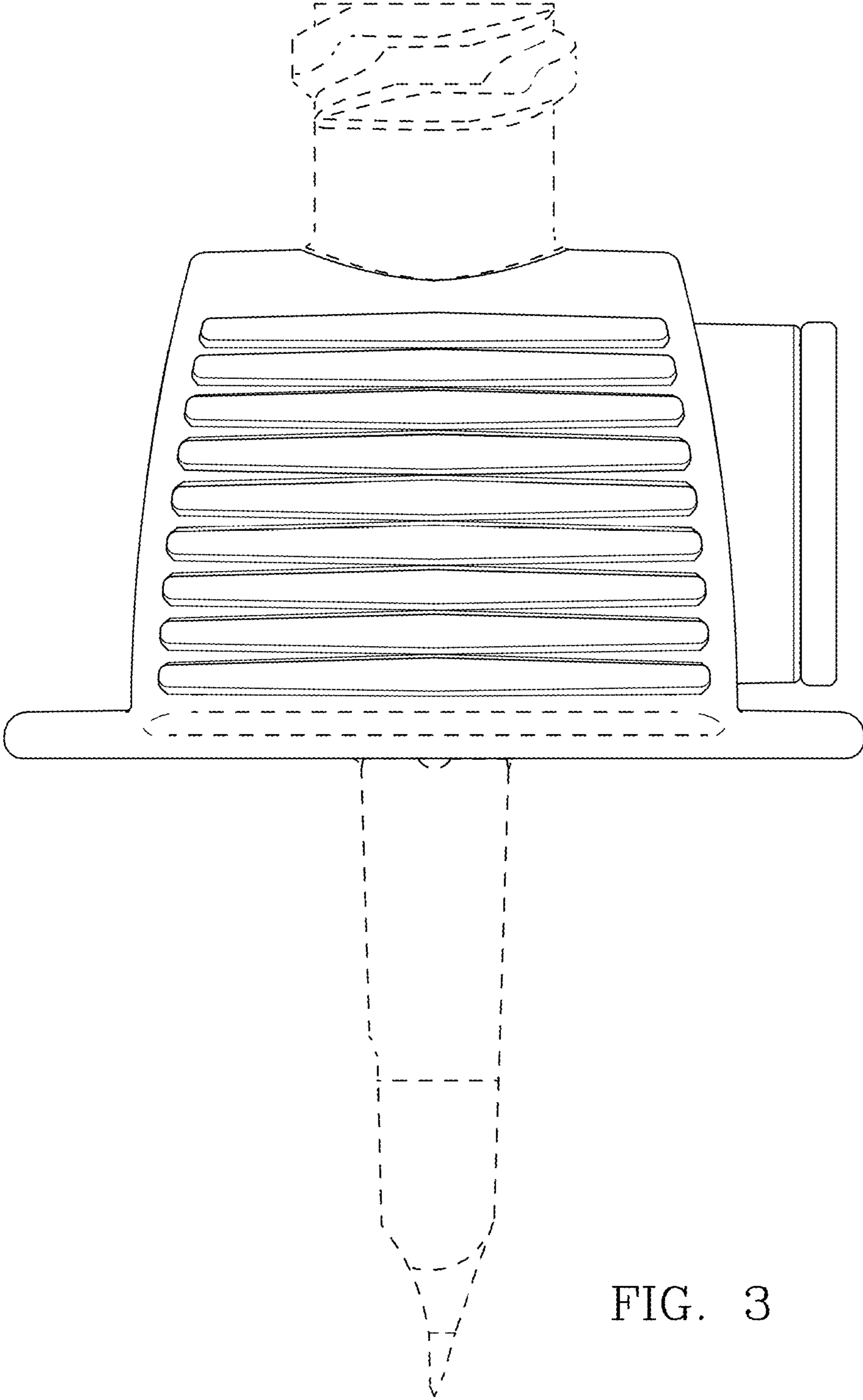

FIG. 3

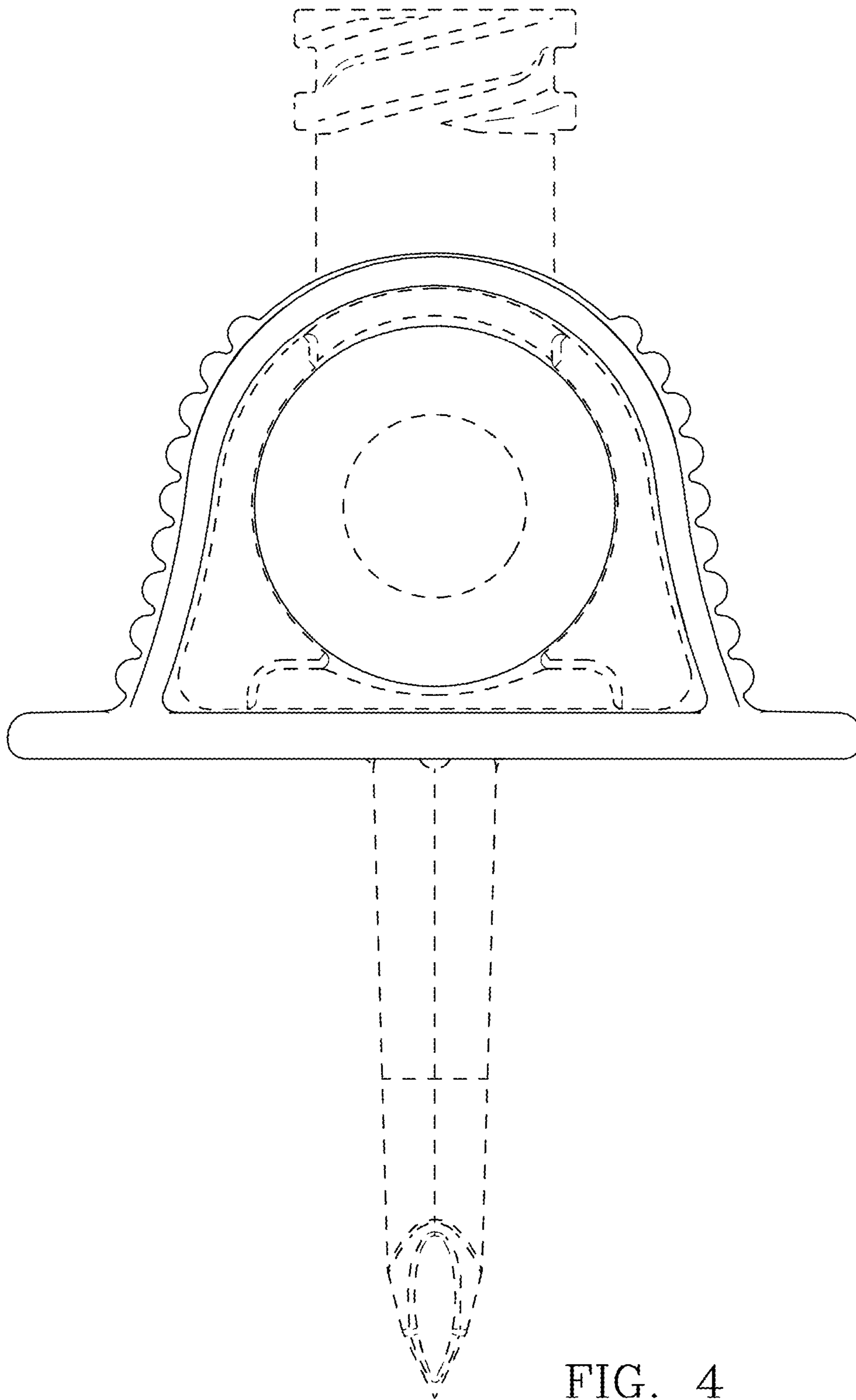

FIG. 4

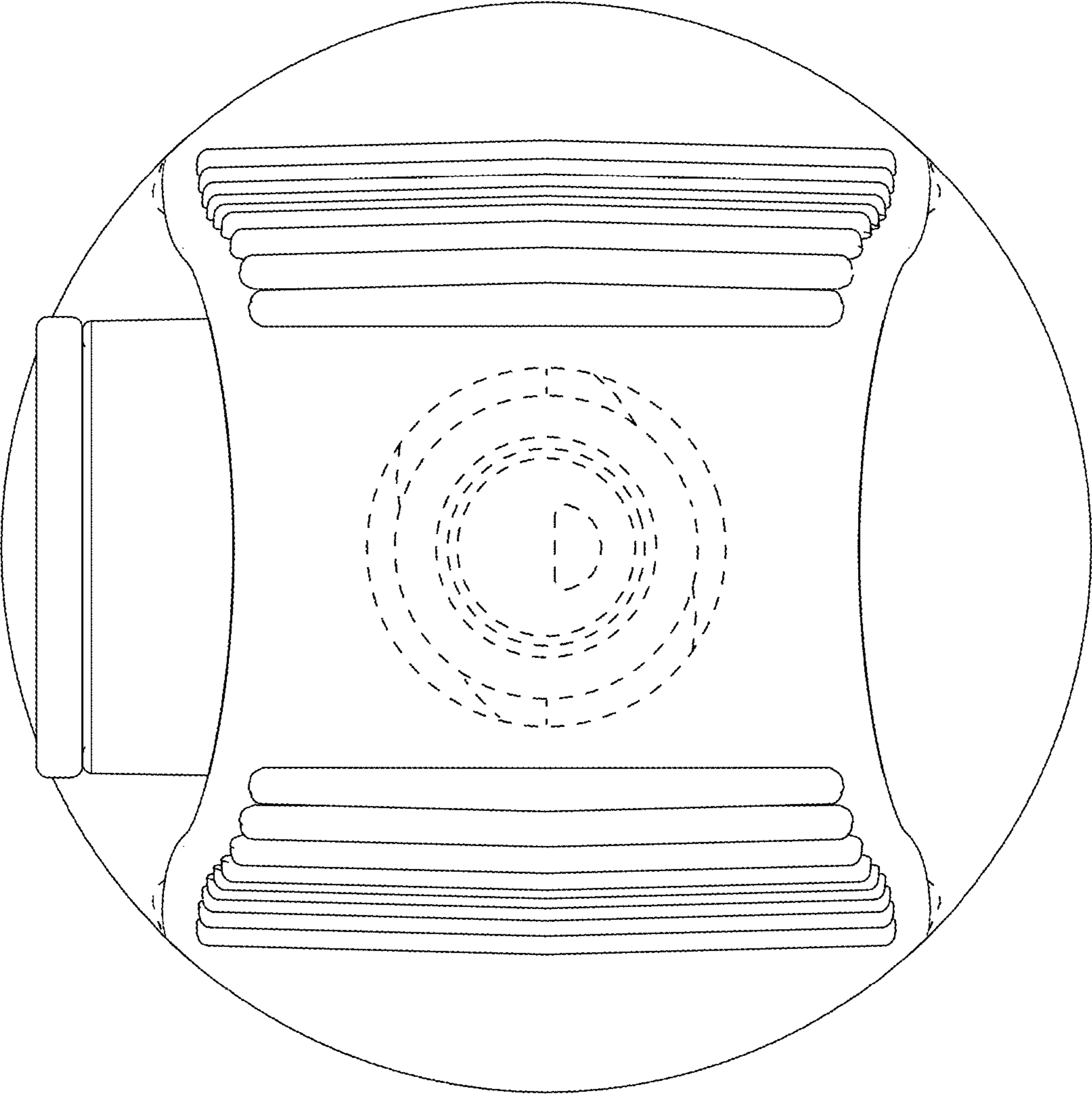

FIG. 5

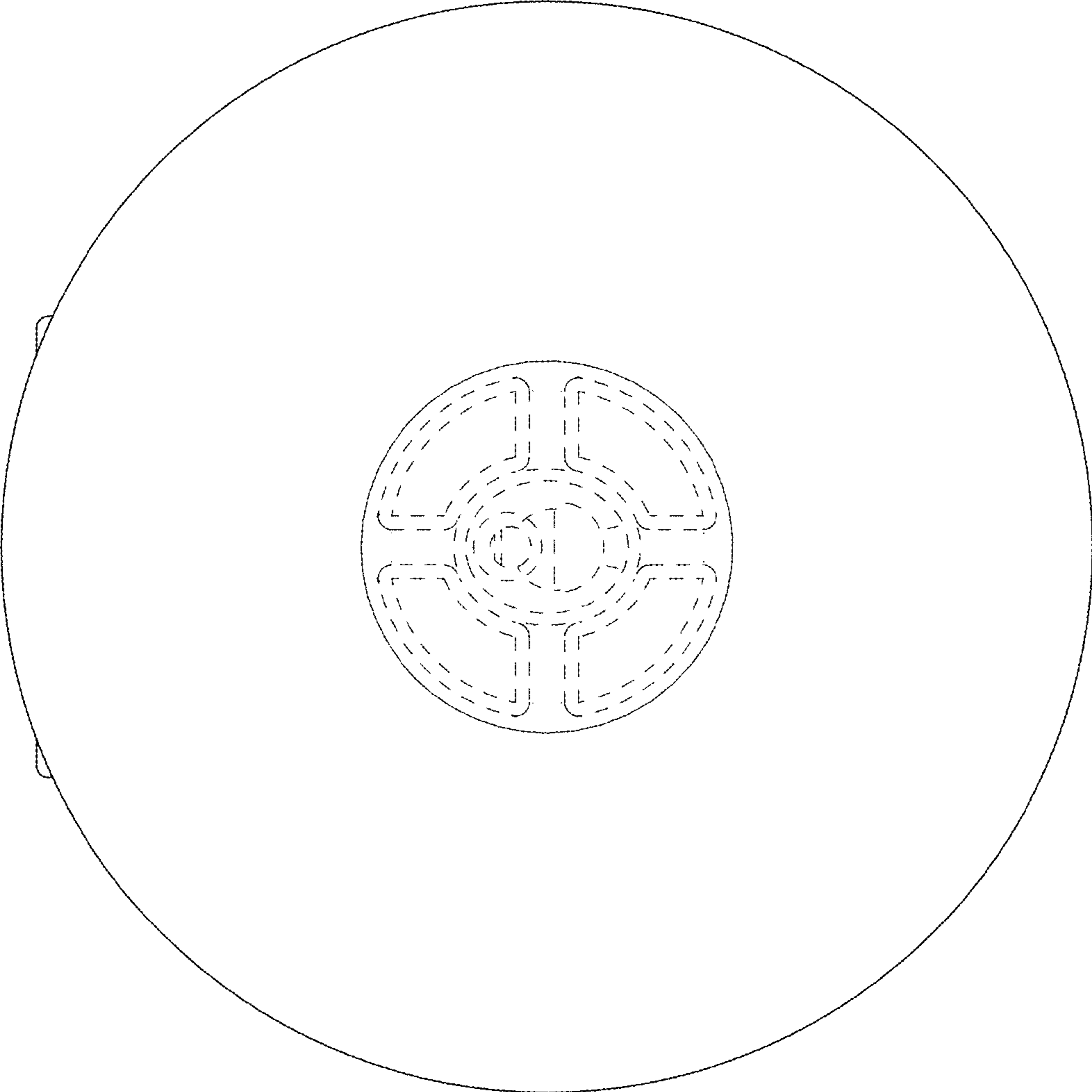

FIG. 6