

US00D769171S

(12) **United States Design Patent**  
**Johnson**

(10) **Patent No.:** **US D769,171 S**

(45) **Date of Patent:** **\*\* Oct. 18, 2016**

(54) **AUTOMOTIVE WHEEL**

(71) Applicant: **Kelly R. Johnson**, City of Industry, CA (US)

(72) Inventor: **Kelly R. Johnson**, City of Industry, CA (US)

(73) Assignee: **THE WHEEL GROUP**, City of Industry, CA (US)

(\*\*) Term: **15 Years**

(21) Appl. No.: **29/533,334**

(22) Filed: **Jul. 16, 2015**

(51) **LOC (10) Cl.** ..... **12-16**

(52) **U.S. Cl.**  
USPC ..... **D12/211**

(58) **Field of Classification Search**  
USPC ..... D12/204–213

CPC ..... B60B 7/00; B60B 7/02; B60B 7/04;  
B60B 7/01; B60B 7/06; B60B 3/02; B60B 3/04;  
B60B 3/06; B60B 3/10; B60B 1/00;  
B60B 1/08; B60B 1/10; B60B 1/12  
See application file for complete search history.

(56) **References Cited**

**U.S. PATENT DOCUMENTS**

D521,438 S \* 5/2006 Nordmann ..... D12/211  
D558,118 S \* 12/2007 Hueller ..... D12/211

D589,428 S \* 3/2009 Scheu ..... D12/211  
D625,675 S \* 10/2010 Juergens ..... D12/209  
D639,716 S \* 6/2011 Juergens ..... D12/211  
D659,068 S \* 5/2012 Johnson ..... D12/211  
D684,519 S \* 6/2013 Garbas ..... D12/211  
D689,421 S \* 9/2013 Wachter ..... D12/211  
D726,626 S \* 4/2015 Mays ..... D12/211  
D731,389 S \* 6/2015 Gotschke ..... D12/211  
D746,756 S \* 1/2016 George ..... D12/211  
D748,034 S \* 1/2016 Hall ..... D12/211  
D753,570 S \* 4/2016 Garbas ..... D12/211  
D760,143 S \* 6/2016 Gallert ..... D12/211

\* cited by examiner

*Primary Examiner* — Stacia Cadmus

(57) **CLAIM**

The ornamental design for an automotive wheel, as show and described.

**DESCRIPTION**

FIG. 1 is a perspective view of an automotive wheel showing my new design; and, FIG. 2 is a front elevational view thereof. The broken line showing of the rear portion of the rim is included for the purpose of illustrating environment and forms no part of the claimed design.

**1 Claim, 2 Drawing Sheets**

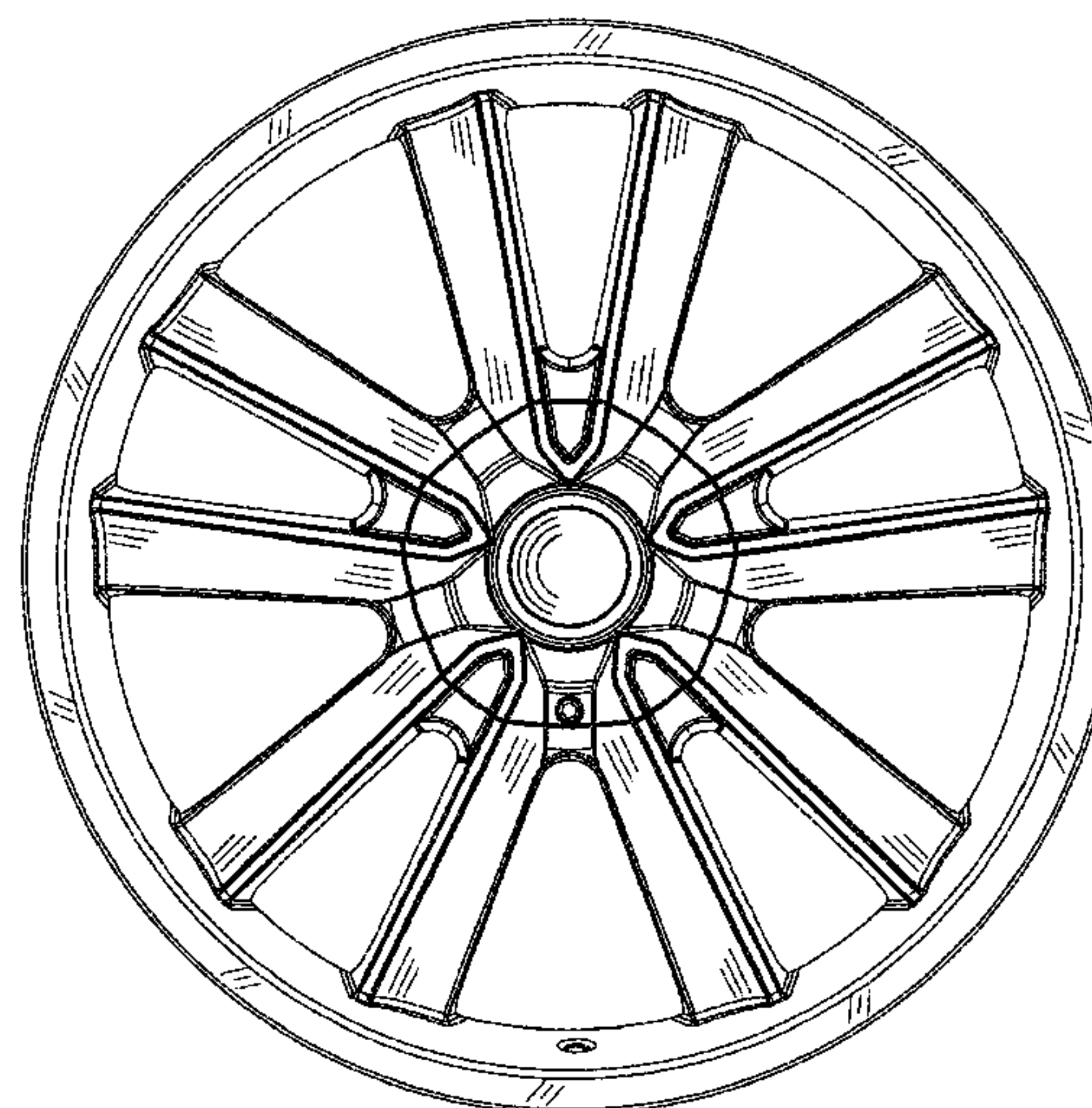
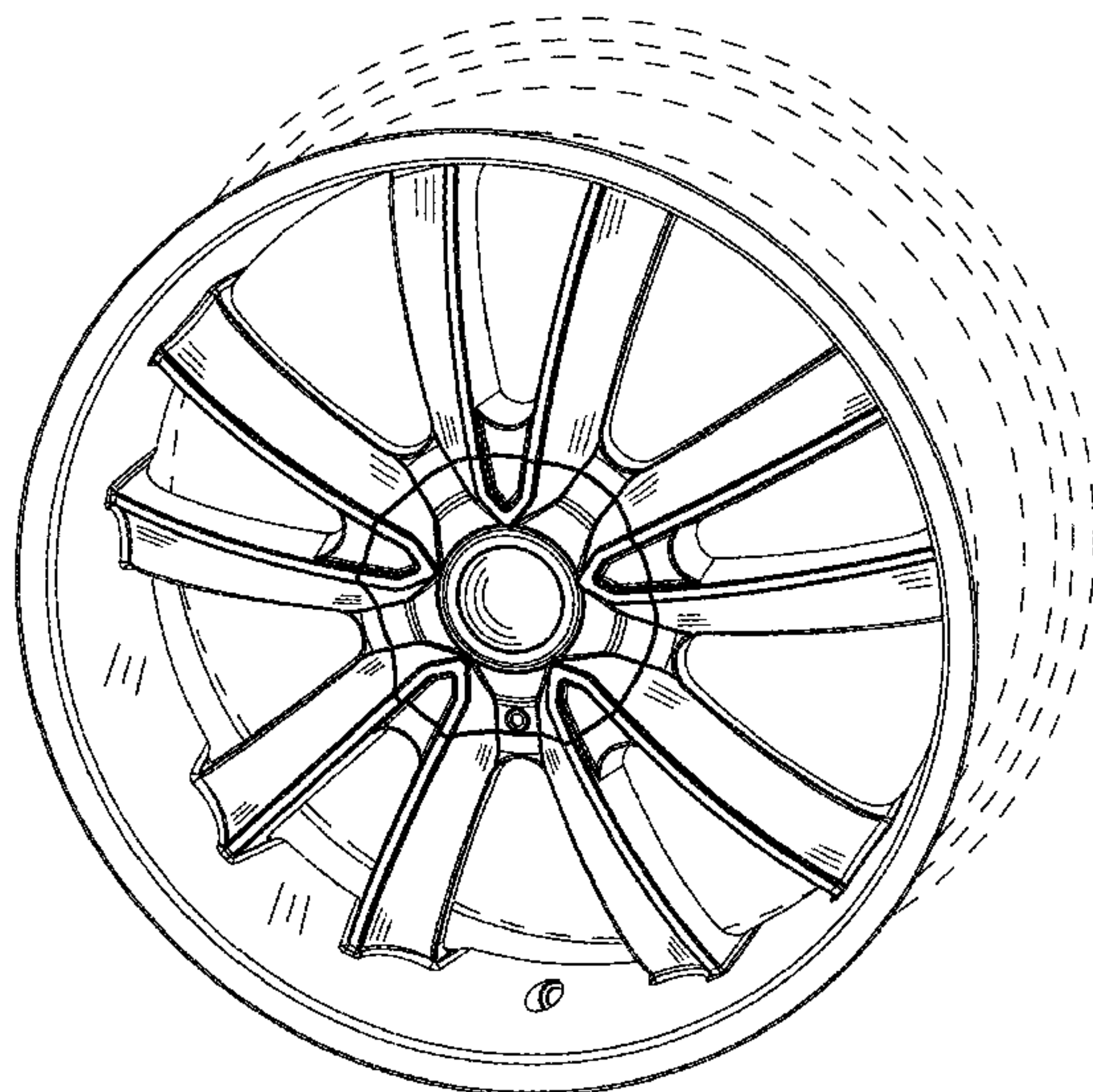

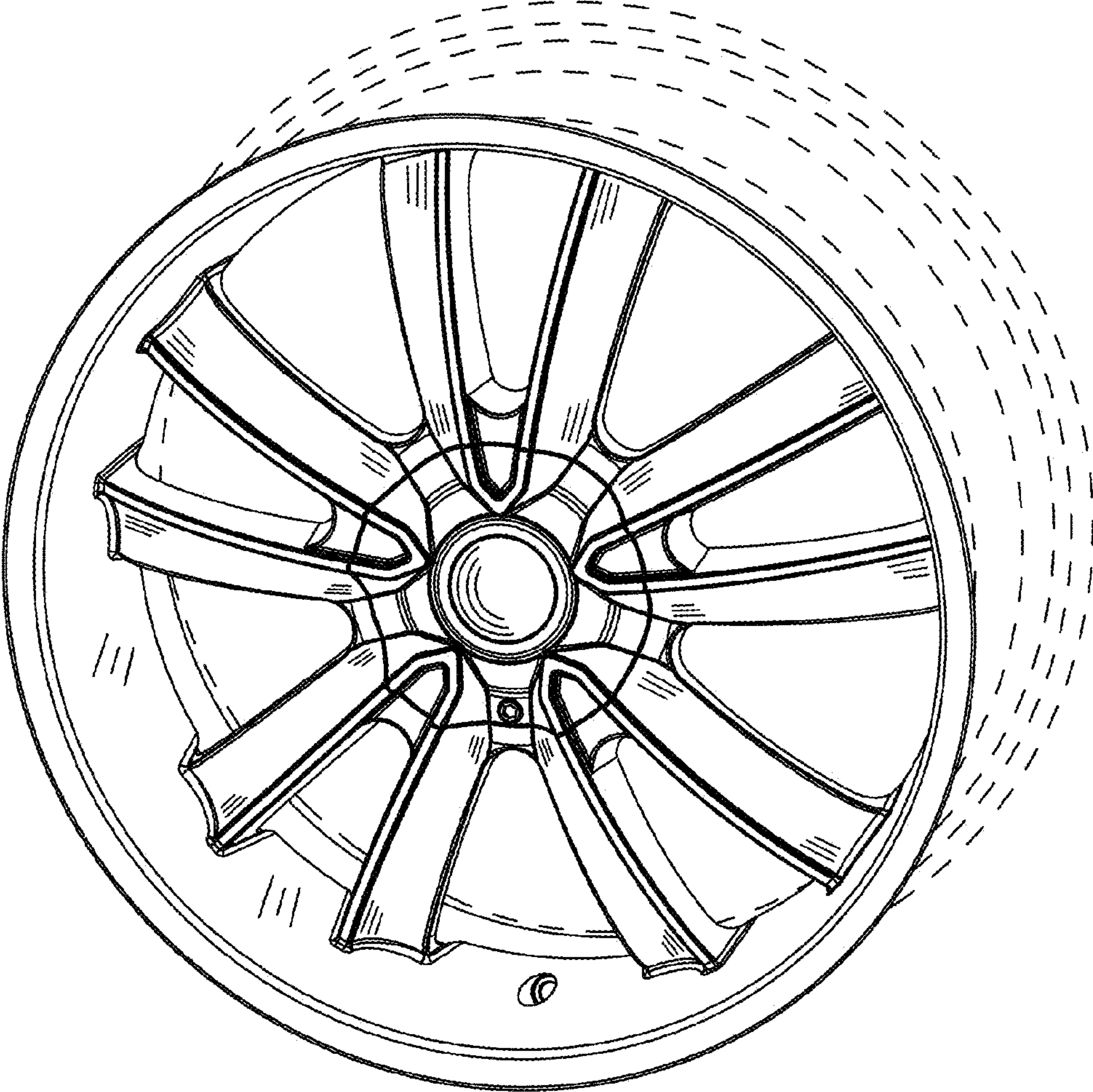

FIG.1



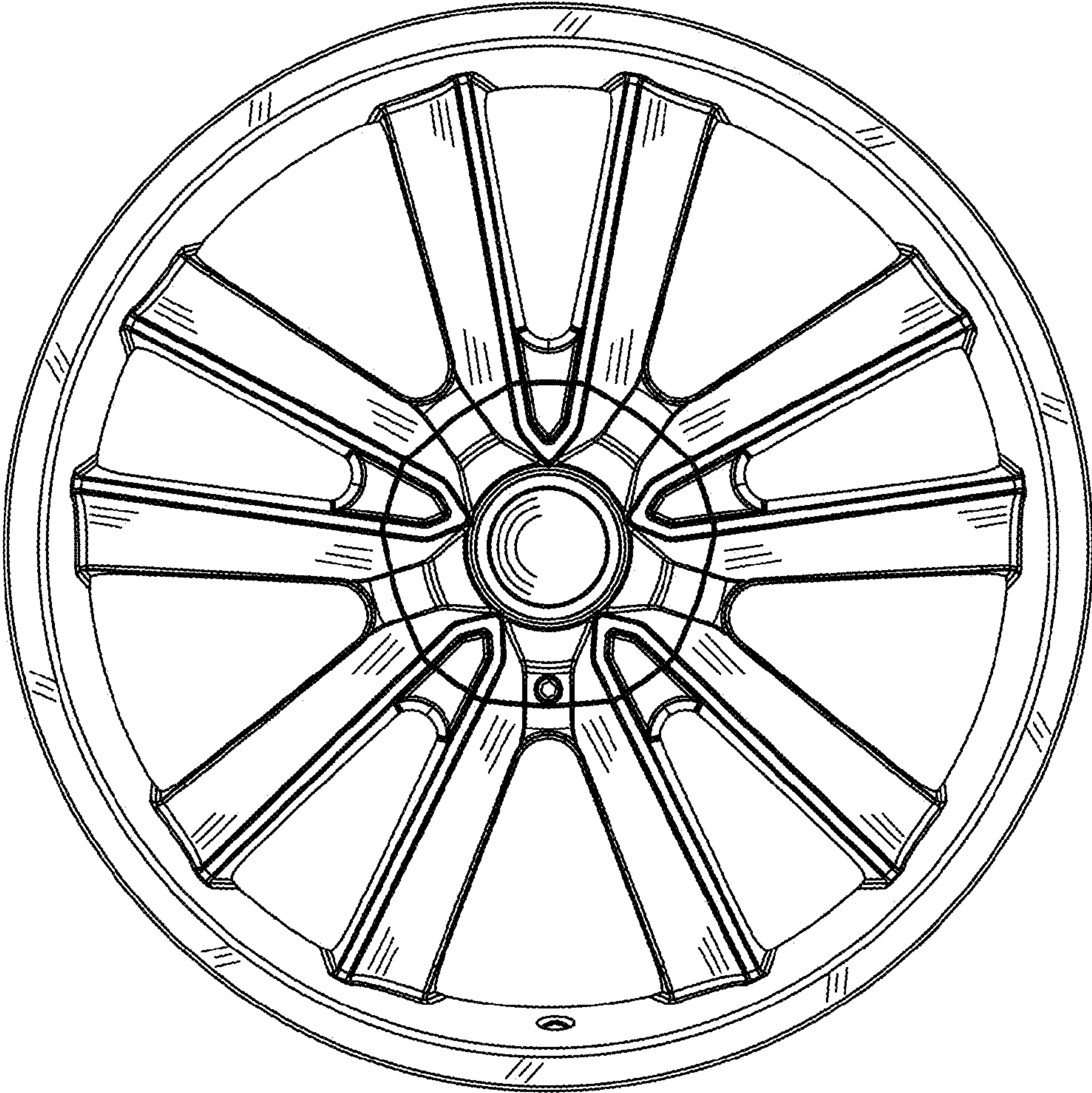

FIG. 2