



US00D768998S

(12) **United States Design Patent** (10) **Patent No.:** **US D768,998 S**
Kim et al. (45) **Date of Patent:** **** Oct. 18, 2016**

(54) **PORTION OF A MAKE-UP BRUSH**
(71) Applicants: **Edward Kim**, Cerritos, CA (US);
Guang Zhen Liu, Yingkou (CN)
(72) Inventors: **Edward Kim**, Cerritos, CA (US);
Guang Zhen Liu, Yingkou (CN)
(73) Assignee: **Nexagen Corp.**, Cerritos, CA (US)
(**) Term: **15 Years**
(21) Appl. No.: **29/528,407**
(22) Filed: **May 28, 2015**
(51) **LOC (10) Cl.** **04-02**
(52) **U.S. Cl.**
USPC **D4/127**
(58) **Field of Classification Search**
USPC D4/100, 102, 127-135, 138, 199;
D7/393; D8/47, 75, 82, 83, 107, 300,
D8/307-313; D9/723-729; D19/100, 108,
D19/115, 125; D24/200, 211, 214
CPC A46B 5/00; A46B 5/02; A46B 5/021;
A46B 9/00; A46B 9/02; A46B 9/021; A46B
9/023; A46B 9/025; A46B 9/026; A46B
9/028; A46B 11/00; A46B 11/0006; A46B
11/001; A46B 13/00; A46B 13/001; A46B
13/02; A46B 13/023; A46B 15/0002; A46B
2200/10; A46B 2200/102; A46B 2200/1033;
A46B 2200/104; A46B 2200/1046; A46B
2200/30; A46B 2200/3006; A46B 2200/3013;
A46B 2200/3033; A46B 2200/3093
See application file for complete search history.

(56) **References Cited**
U.S. PATENT DOCUMENTS
D249,600 S * 9/1978 Bowman D4/135
D450,930 S * 11/2001 Mink D4/135
D450,931 S * 11/2001 Mink D4/135
D452,948 S * 1/2002 Mink D4/138
D528,304 S * 9/2006 Langer D4/116

D529,719 S * 10/2006 Langer D4/116
(Continued)

FOREIGN PATENT DOCUMENTS

WO WO 2010004207 A2 * 1/2010 A46B 9/021

OTHER PUBLICATIONS

BDHD, Maestro 988 BDHD Phase I Large Founigation/Powder
Brush, as posted at bdelliumtools [online], posting date not avail-
able [site visited Aug. 1, 2016]. Available from the Internet, <URL:
http://bdelliumtools.com/new-arrival/bdhd.html>.*
Zoeva, Rose Golden Brush Set, as posted at Beauty Bay [online],
first review posted Oct. 11, 2014 [site visited Apr. 29, 2016].
Available from the Internet, <URL: http://www.beautybay.com/
cosmetics/zoeva/rosegoldenbrushset/>.*

(Continued)

Primary Examiner — Catheri Oliver-Garcia
Assistant Examiner — Rebekah A Caruso
(74) *Attorney, Agent, or Firm* — Dunlap Bennett &
Ludwig PLLC

(57) **CLAIM**
The ornamental design for a portion of a make-up brush, as
shown and described.

DESCRIPTION

FIG. 1 is a front perspective view of a first embodiment of
a portion of a make-up brush;
FIG. 2 is a front elevation view of the first embodiment
thereof;
FIG. 3 is a rear elevation view of the first embodiment
thereof;
FIG. 4 is a left side elevation view of the first embodiment
thereof, the right side elevation view being a mirror image
thereof;
FIG. 5 is a top plan view of the first embodiment thereof;
and,
FIG. 6 is a bottom plan view of the first embodiment thereof.
The broken lines shown in the drawings illustrate portions of
the portion of a make-up brush that form no part of the
claimed design.

1 Claim, 3 Drawing Sheets

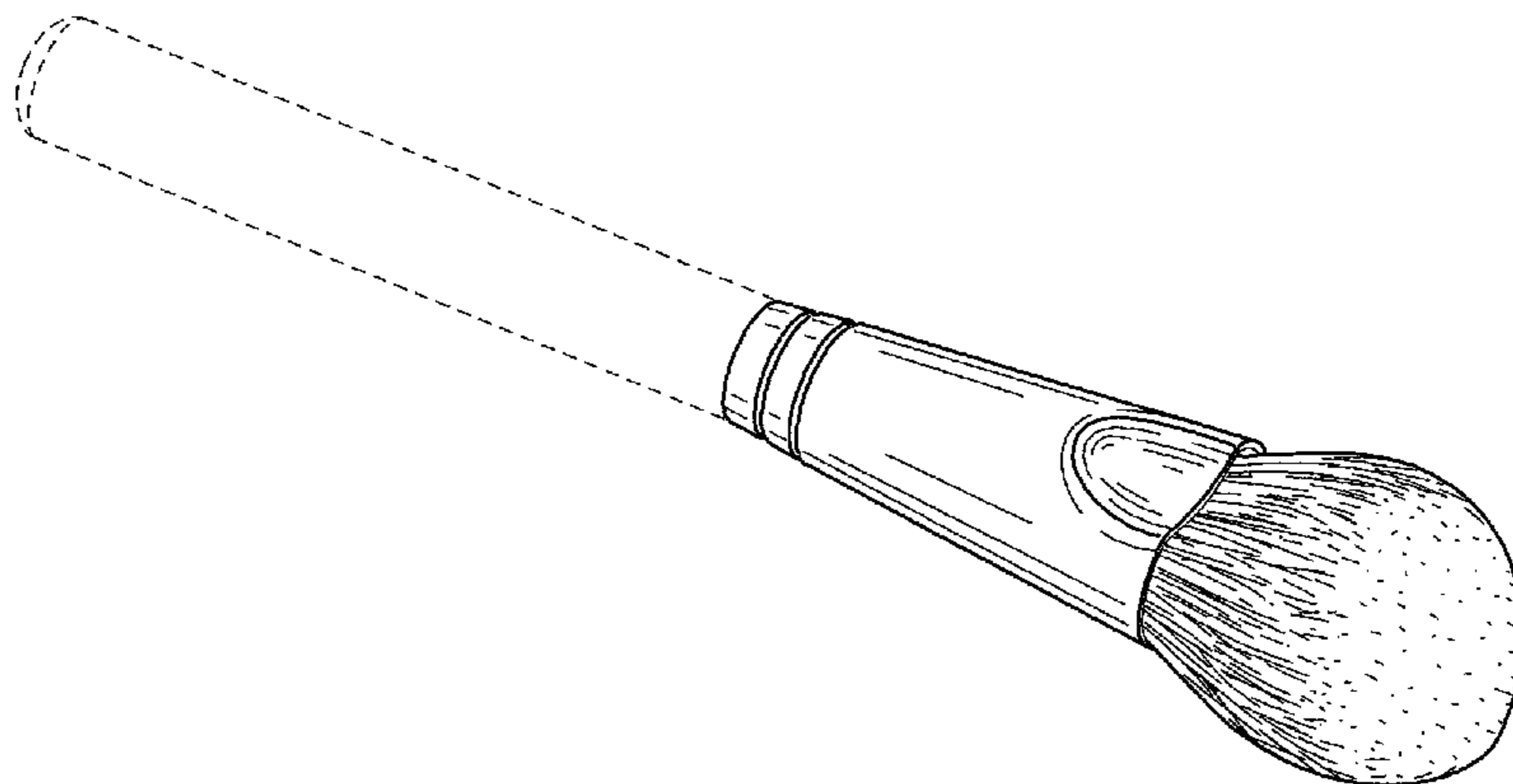

(56)

References Cited

U.S. PATENT DOCUMENTS

7,416,080 B1 * 8/2008 Langer A45D 33/00
206/15.2
D718,060 S * 11/2014 Filho D4/199
D749,858 S * 2/2016 Snook D4/135
D749,859 S * 2/2016 Snook D4/135
D756,127 S * 5/2016 Nicoline D28/7

OTHER PUBLICATIONS

Charlotte Tilbury, Magic Complexion Brush, posted at Bergdorf Goodman [online], date not available [site visited Apr. 29, 2016]. Available from the Internet, <URL: http://www.bergdorfgoodman.com/Beauty/Tools-Brushes-Bags/Makeup-Brushes/cat243414_cat243441_cat000005/c.cat?itemId=cat243414&pageSize=30&No=0&queryString=&N=&breadcrumb=true>.*

* cited by examiner

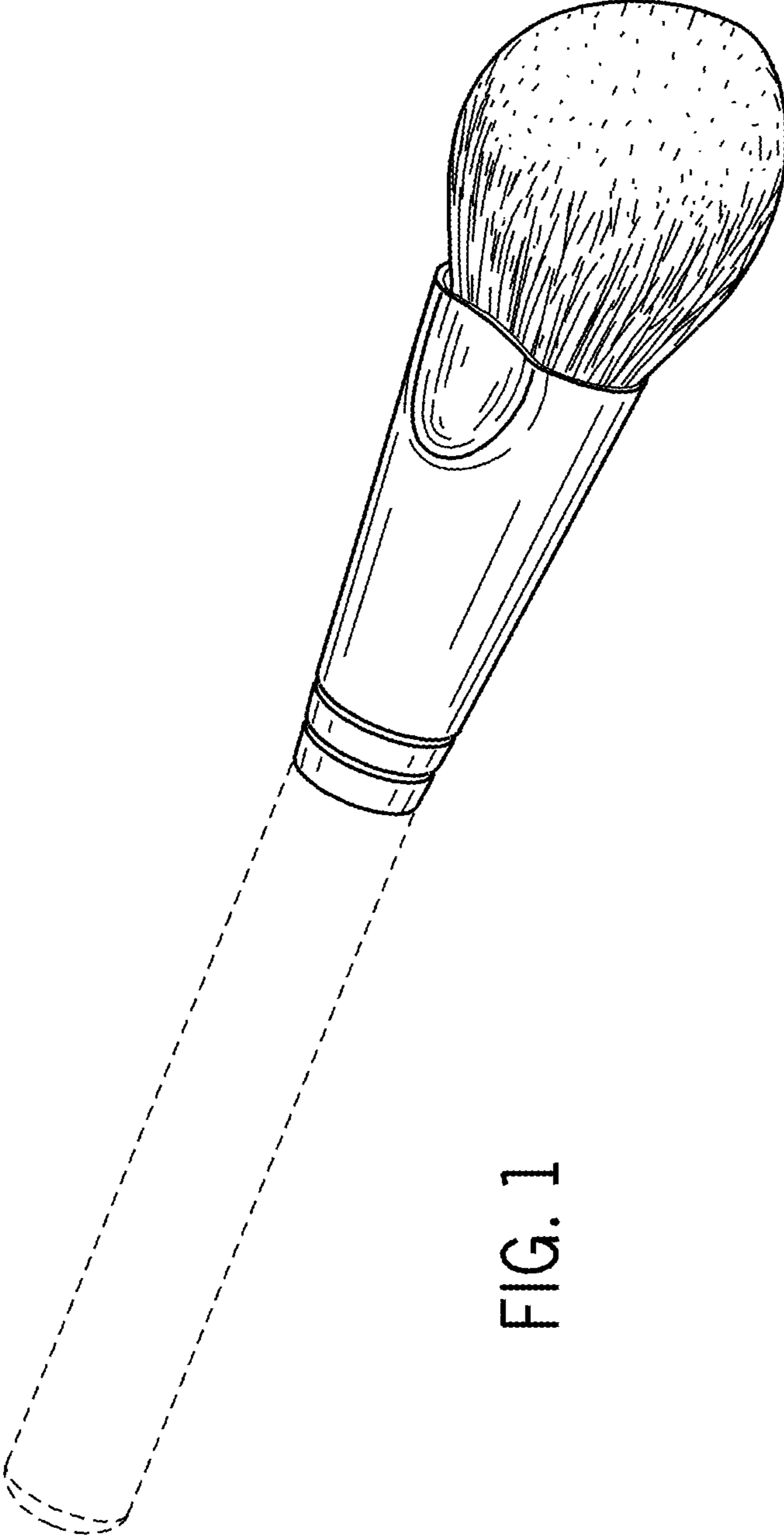

FIG. 1

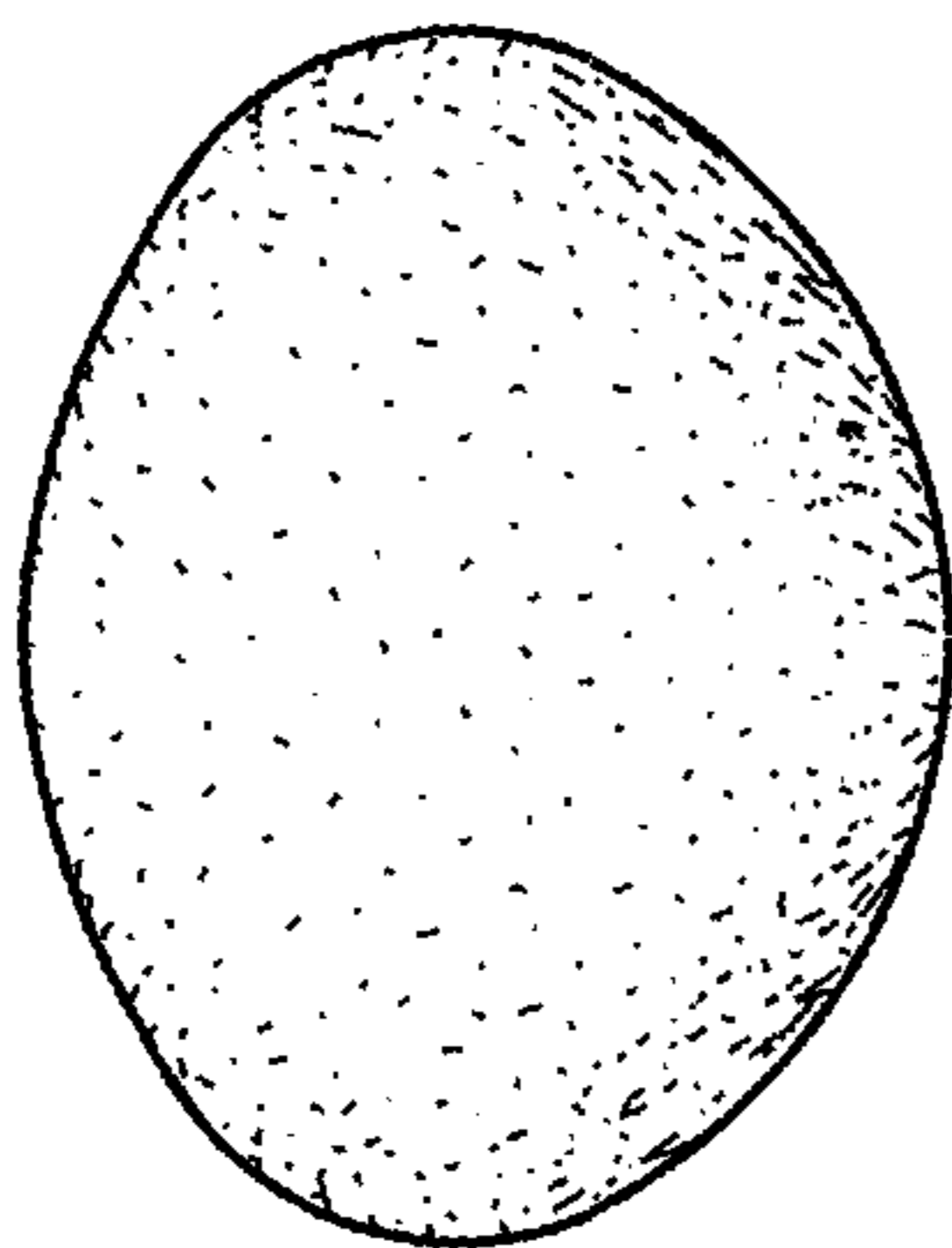

FIG. 2

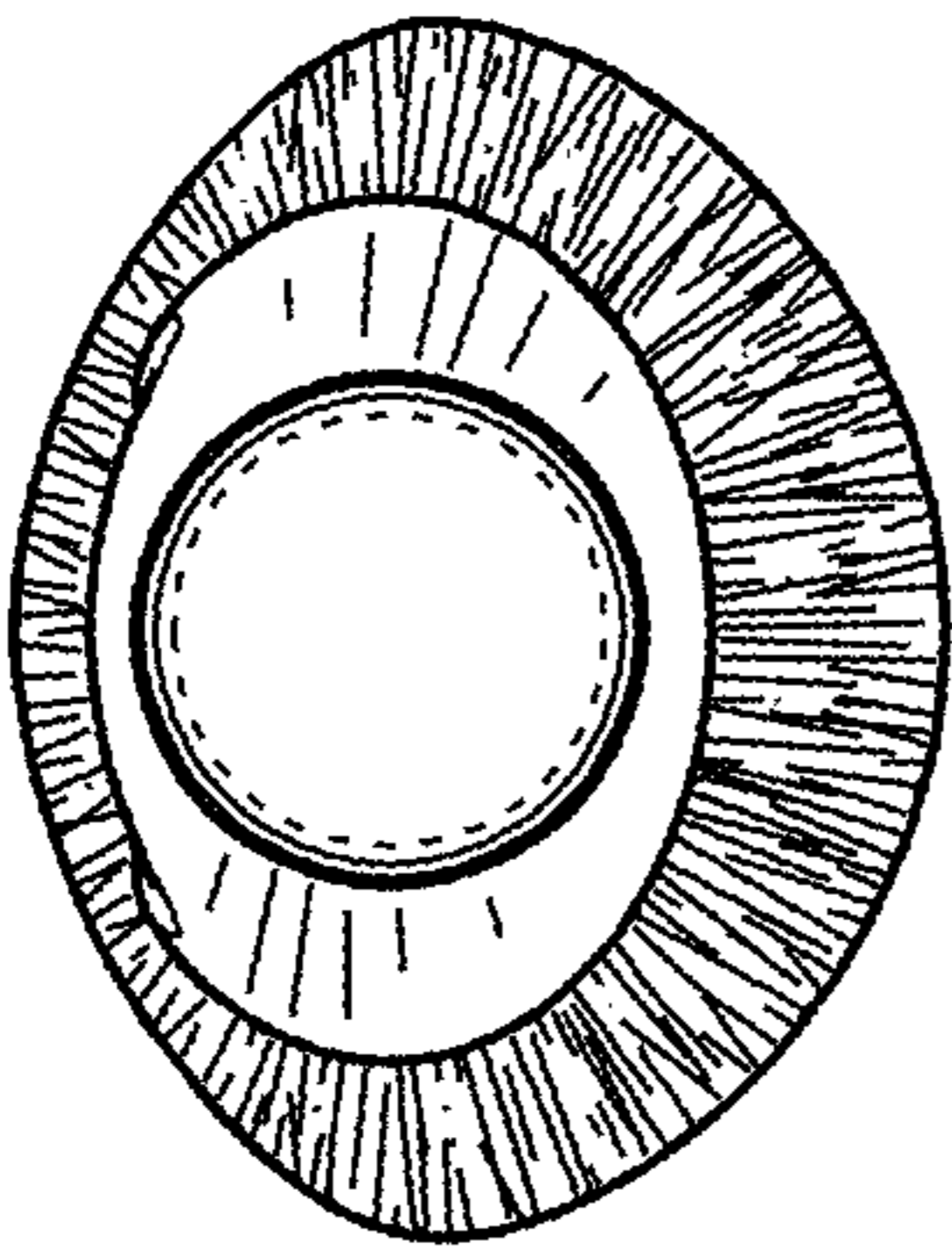

FIG. 3

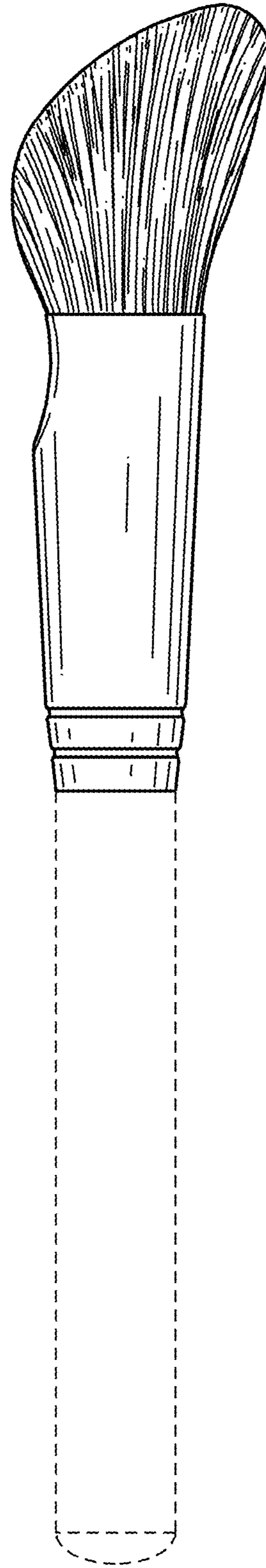

FIG. 4

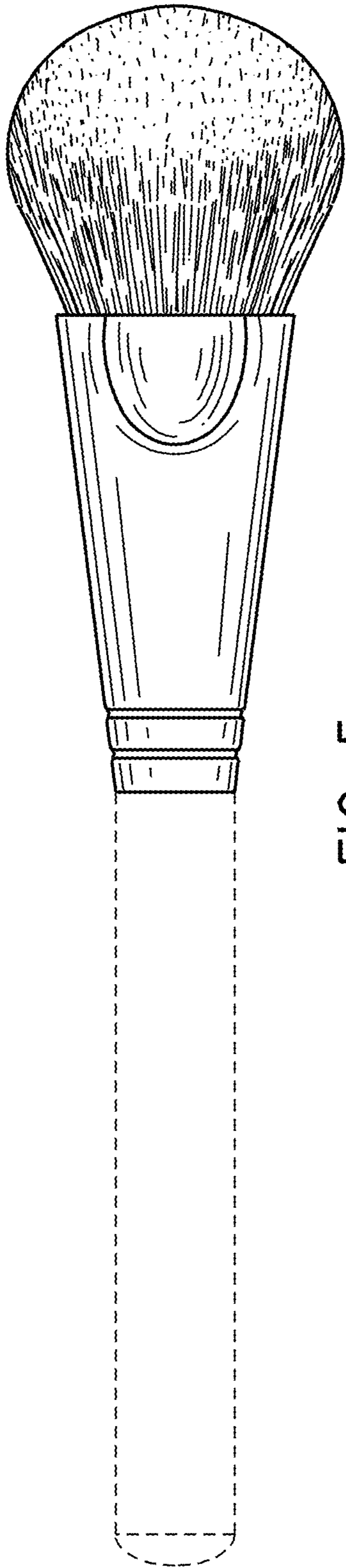

FIG. 5

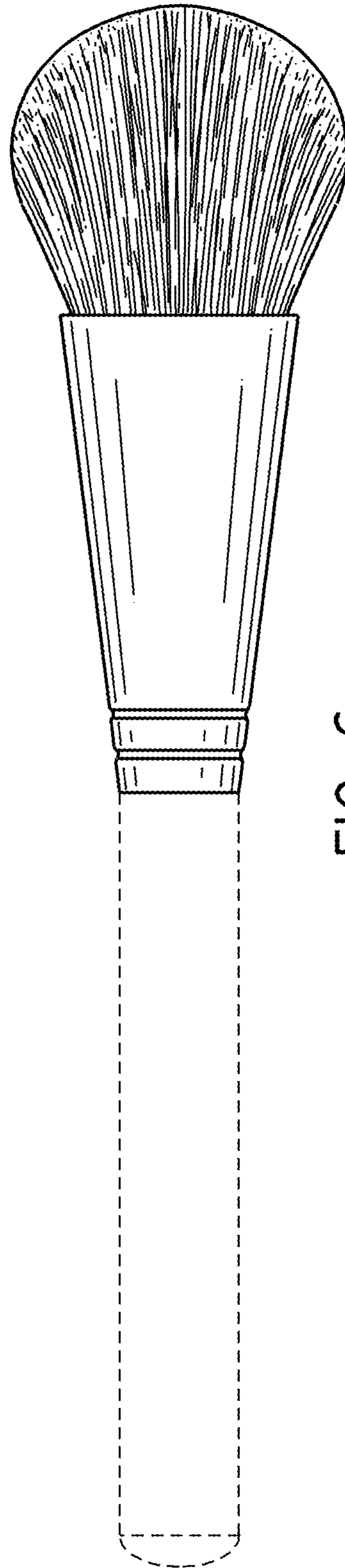

FIG. 6