



US00D768539S

(12) **United States Design Patent** (10) **Patent No.:** **US D768,539 S**
Lee (45) **Date of Patent:** **** Oct. 11, 2016**

(54) **AERIAL VEHICLE**
(71) Applicant: **GoPro, Inc.**, San Mateo, CA (US)
(72) Inventor: **Seung Heon Lee**, Cupertino, CA (US)
(73) Assignee: **GoPro, Inc.**, San Mateo, CA (US)
(**) Term: **15 Years**
(21) Appl. No.: **29/535,225**
(22) Filed: **Aug. 4, 2015**
(51) **LOC (10) Cl.** **12-07**
(52) **U.S. Cl.**
USPC **D12/16.1; D21/441**
(58) **Field of Classification Search**
USPC D12/16.1, 319-345; D21/436, 438,
D21/440, 442, 443, 446-451, 453, 441
CPC B64C 39/024; B64C 27/32; B64C
2201/024; B64C 27/12; B64C 39/00; B64C
27/08
See application file for complete search history.

2015/0051755 A1* 2/2015 Erhart A63H 27/12
701/2
2015/0060606 A1* 3/2015 Wang B64C 39/024
244/175
2015/0129711 A1* 5/2015 Caubel B64C 27/08
244/17.23
2015/0210388 A1* 7/2015 Criado B64C 39/10
701/3
2015/0259066 A1* 9/2015 Johannesson B64C 27/08
244/17.27
2015/0321755 A1* 11/2015 Martin B64C 27/50
244/17.23
2015/0336670 A1* 11/2015 Zhang B64C 1/00
244/119
2016/0001879 A1* 1/2016 Johannesson B64C 27/50
416/142
2016/0031275 A1* 2/2016 Monroe B60F 3/0007
244/2
2016/0068261 A1* 3/2016 Niederberger A47L 1/02
244/2

OTHER PUBLICATIONS

Drone by GoPro found online [Apr. 27, 2016] <http://dronegopro.org/>.*

* cited by examiner

Primary Examiner — Robert M Spear
Assistant Examiner — Marissa J Cash
(74) *Attorney, Agent, or Firm* — Fenwick & West LLP

(56) **References Cited**
U.S. PATENT DOCUMENTS
D189,462 S * 12/1960 Vogt D12/329
D197,038 S * 12/1963 Howard D12/329
D465,196 S * 11/2002 Dammar D12/328
D628,658 S * 12/2010 Wurm D21/442
D691,514 S * 10/2013 Wang D12/16.1
D710,452 S * 8/2014 Barajas D12/16.1
D710,453 S * 8/2014 Barajas D12/16.1
D710,454 S * 8/2014 Barajas D12/16.1
8,967,029 B1 * 3/2015 Calvert F41H 13/00
239/171
8,973,861 B2 * 3/2015 Zhou A63H 27/12
244/17.23
9,061,763 B1 * 6/2015 Christensen A63H 17/28
9,099,902 B2 * 8/2015 Chen H02K 5/225
D741,751 S * 10/2015 Klaptocz D12/16.1
D741,779 S * 10/2015 Hsiao D12/16.1
2014/0263823 A1 * 9/2014 Wang B64C 39/028
244/17.23
2014/0339355 A1 * 11/2014 Olm B64C 27/08
244/17.23

(57) **CLAIM**
The ornamental design for an aerial vehicle, as shown and described.

DESCRIPTION

FIG. 1 is a front, top and left side perspective view of a first embodiment of an aerial vehicle;
FIG. 2 is a rear, top and right side perspective view of the first embodiment of the aerial vehicle;
FIG. 3 is a front, bottom and right side perspective view of the first embodiment of the aerial vehicle;
FIG. 4 is a rear, bottom and left side perspective view of the first embodiment of the aerial vehicle;
FIG. 5 is a front elevational view of the first embodiment of the aerial vehicle;

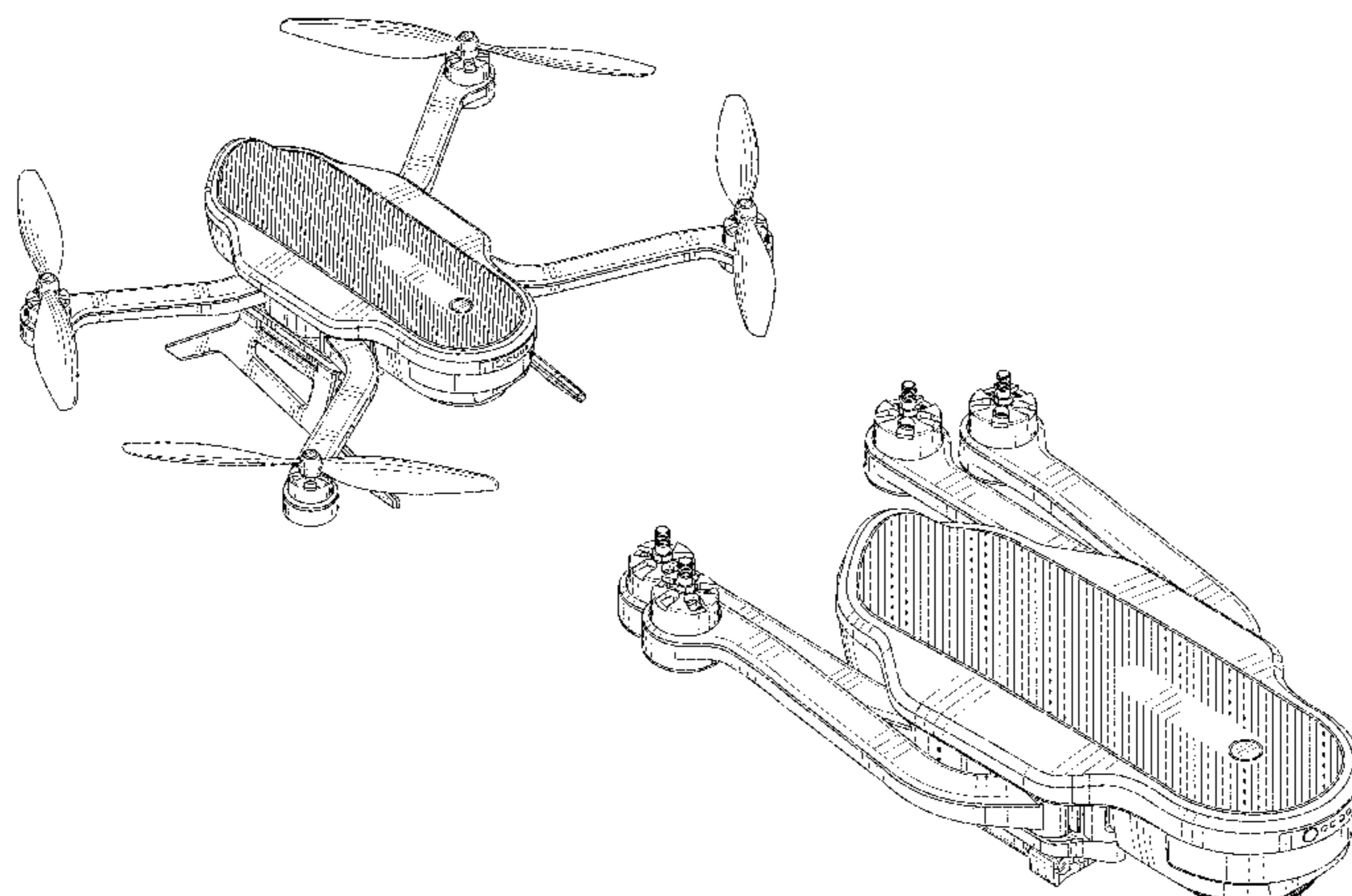

FIG. 6 is a rear elevational view of the first embodiment of the aerial vehicle;

FIG. 7 is a left side elevational view of the first embodiment of the aerial vehicle;

FIG. 8 is a right side elevational view of the first embodiment of the aerial vehicle;

FIG. 9 is a top plan view of the first embodiment of the aerial vehicle;

FIG. 10 is a bottom plan view of the first embodiment of the aerial vehicle;

FIG. 11 is a front, top and left side perspective view of the second embodiment of the aerial vehicle with folded propeller arms, folded landing gear, and without propellers;

FIG. 12 is a rear, top and right side perspective view of the second embodiment of the aerial vehicle with folded propeller arms, folded landing gear, and without propellers;

FIG. 13 is a front, bottom and right side perspective view of the second embodiment of the aerial vehicle with folded propeller arms, folded landing gear, and without propellers;

FIG. 14 is a rear, bottom and left side perspective view of the second embodiment of the aerial vehicle with folded propeller arms, folded landing gear, and without propellers;

FIG. 15 is a front elevational view of the second embodiment of the aerial vehicle with folded propeller arms, folded landing gear, and without propellers;

FIG. 16 is a rear elevational view of the second embodiment of the aerial vehicle with folded propeller arms, folded landing gear, and without propellers;

FIG. 17 is a left side elevational view of the second embodiment of the aerial vehicle with folded propeller arms, folded landing gear, and without propellers;

FIG. 18 is a right side elevational view of the second embodiment of the aerial vehicle with folded propeller arms, folded landing gear, and without propellers;

FIG. 19 is a top plan view of the second embodiment of the aerial vehicle with folded propeller arms, folded landing gear, and without propellers;

FIG. 20 is a bottom plan view of the second embodiment of the aerial vehicle with folded propeller arms, folded landing gear, and without propellers;

FIG. 21 is a front, top and left side perspective view of the third embodiment of an aerial vehicle;

FIG. 22 is a rear, top and right side perspective view of the third embodiment of the aerial vehicle;

FIG. 23 is a front, bottom and right side perspective view of the third embodiment of the aerial vehicle;

FIG. 24 is a rear, bottom and left side perspective view of the third embodiment of the aerial vehicle;

FIG. 25 is a front elevational view of the third embodiment of the aerial vehicle;

FIG. 26 is a rear elevational view of the third embodiment of the aerial vehicle;

FIG. 27 is a left side elevational view of the third embodiment of the aerial vehicle;

FIG. 28 is a right side elevational view of the third embodiment of the aerial vehicle;

FIG. 29 is a top plan view of the third embodiment of the aerial vehicle; and,

FIG. 30 is a bottom plan view of the third embodiment of the aerial vehicle.

The broken line showing of propellers depicts environment and forms no part of the claim.

1 Claim, 30 Drawing Sheets

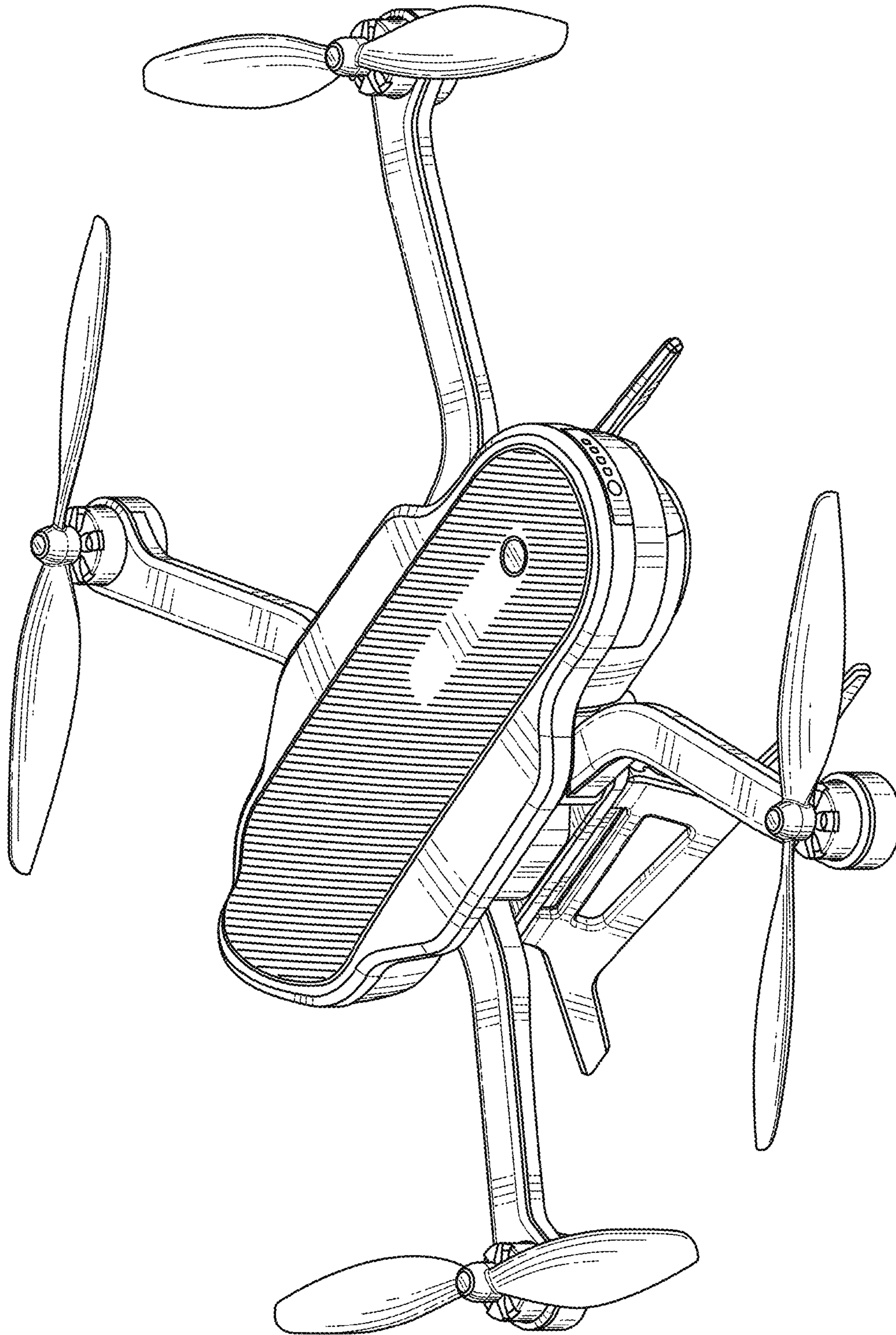

FIG. 1

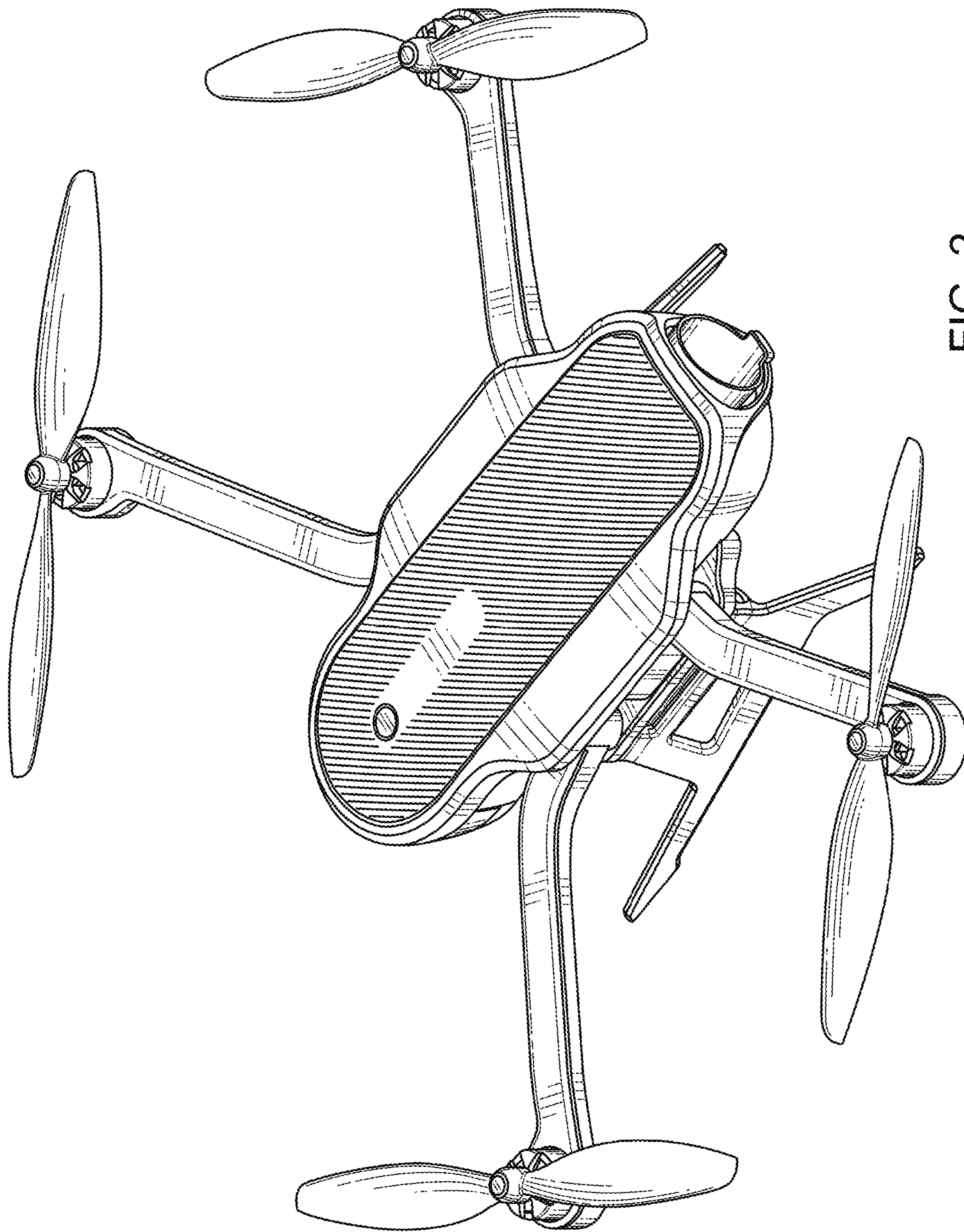

FIG. 2

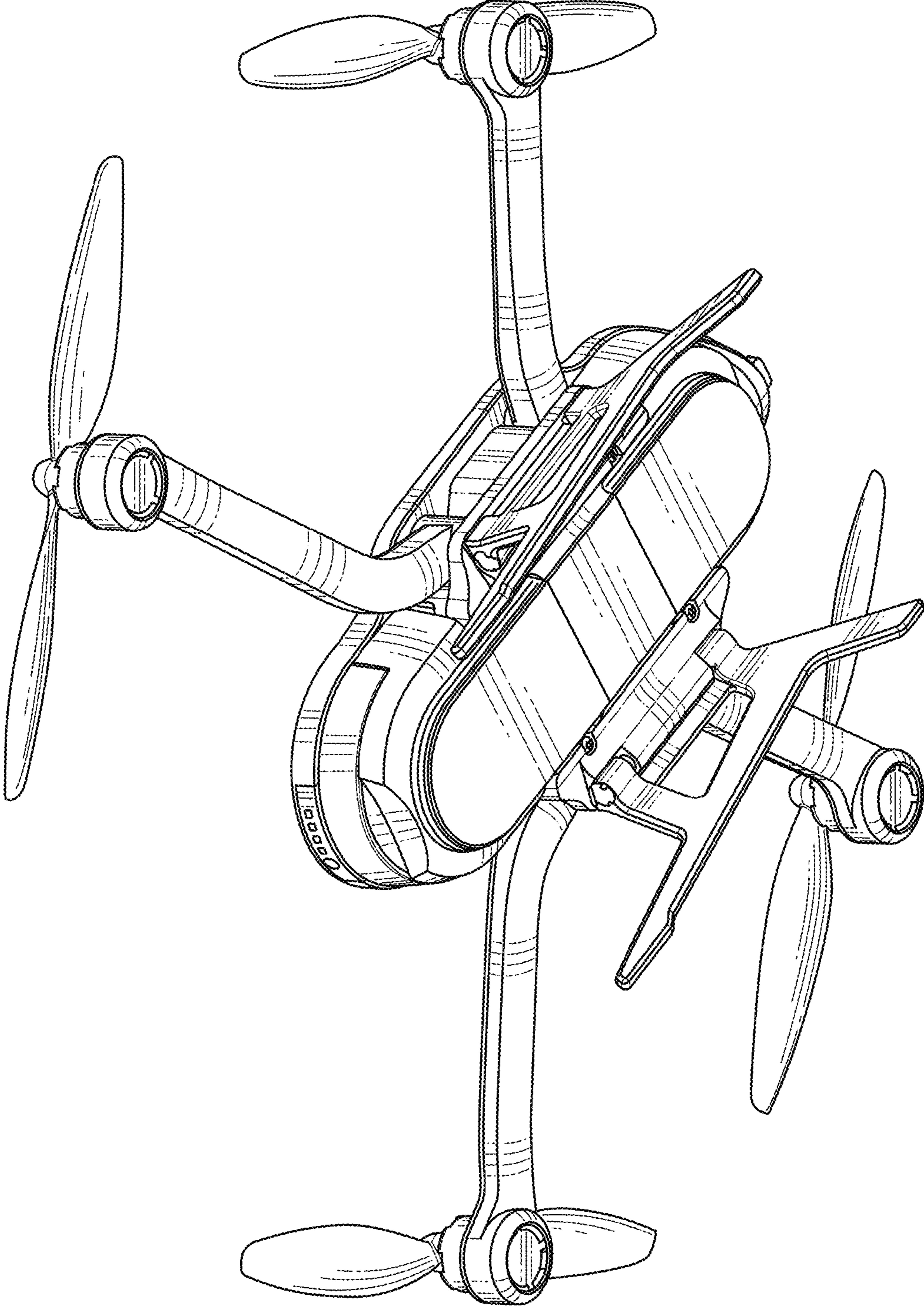

FIG. 3

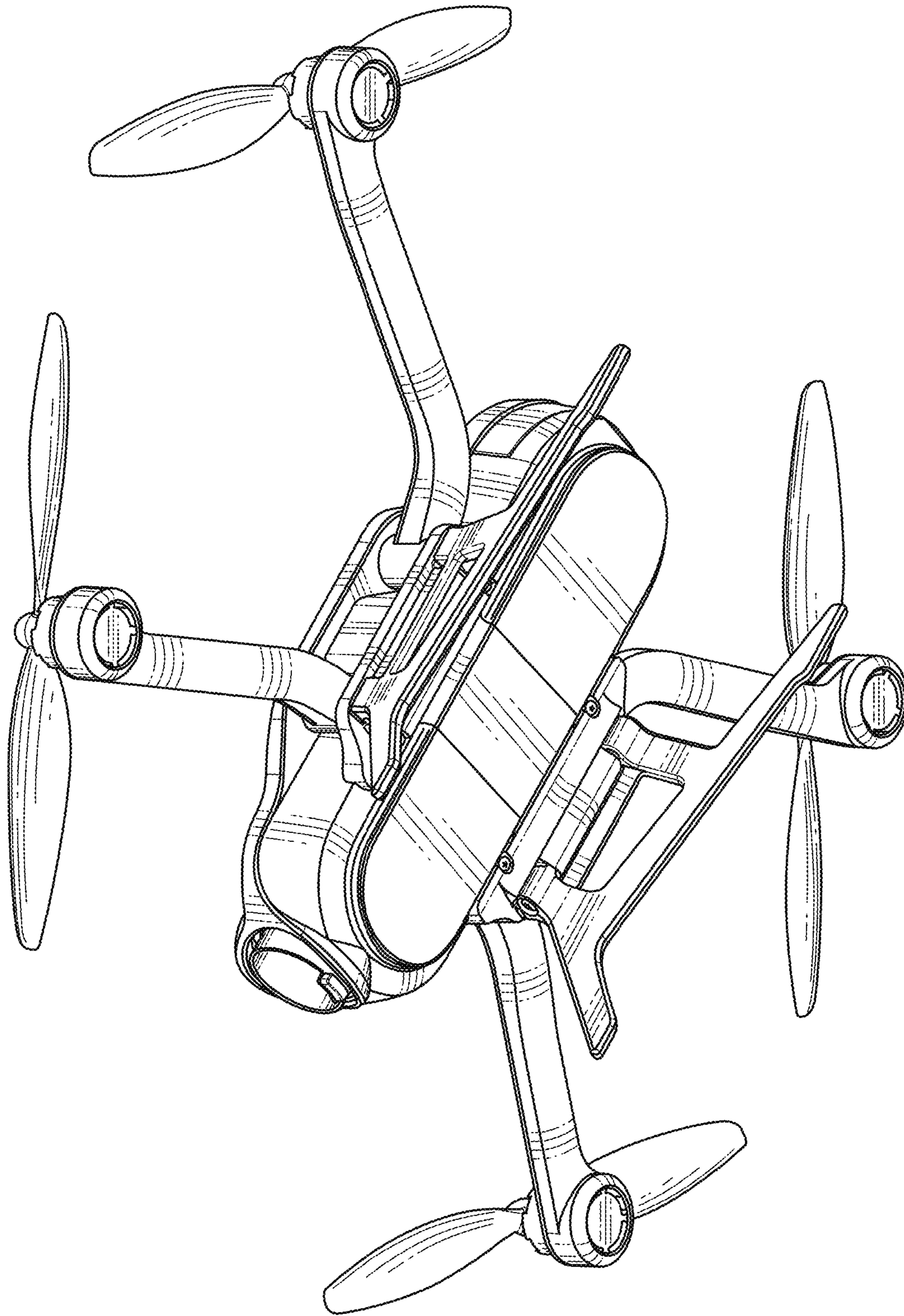

FIG. 4

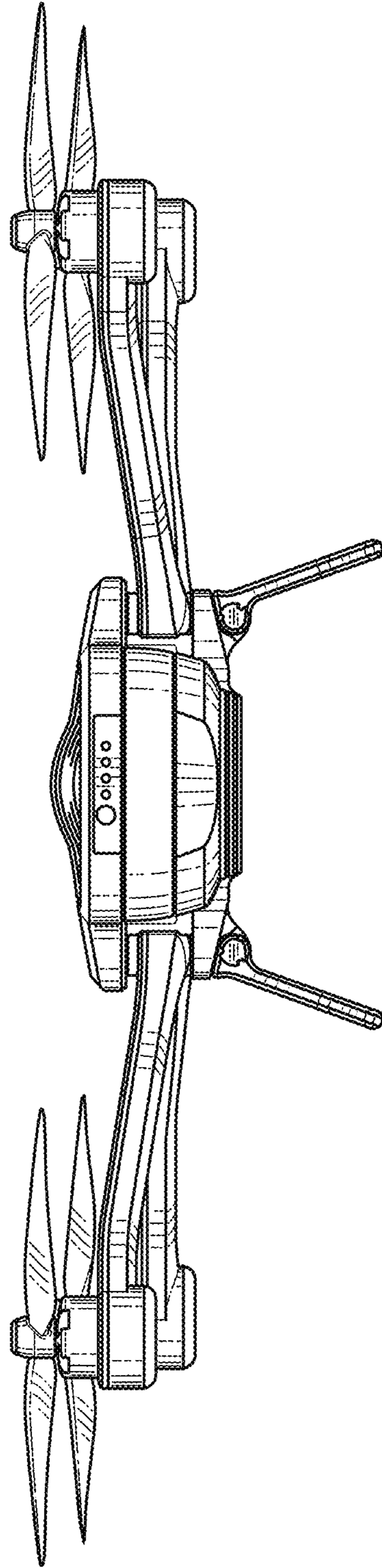

FIG. 5

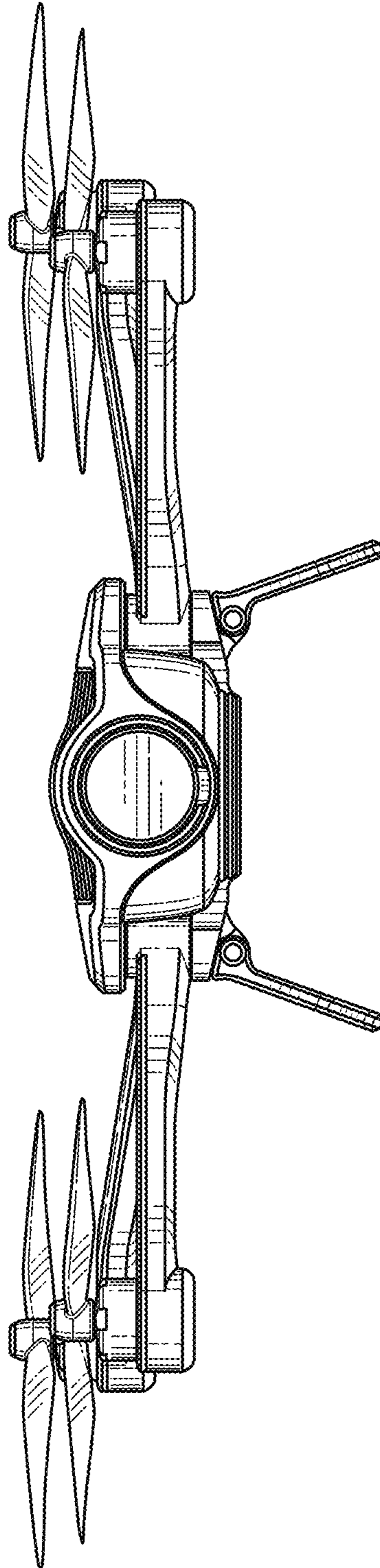

FIG. 6

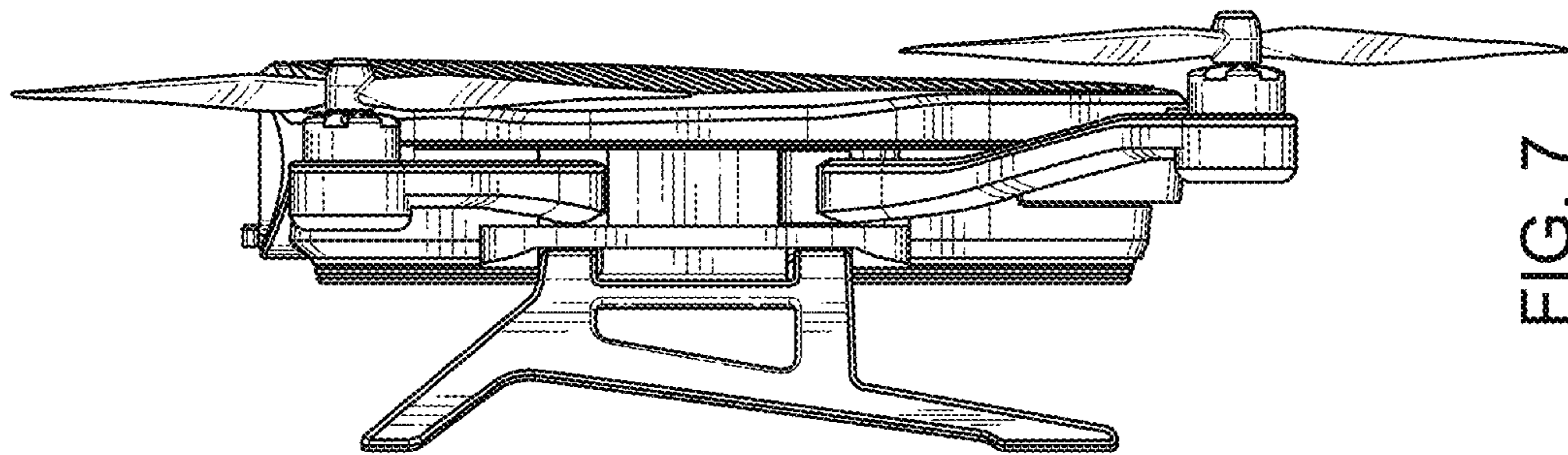

FIG. 7

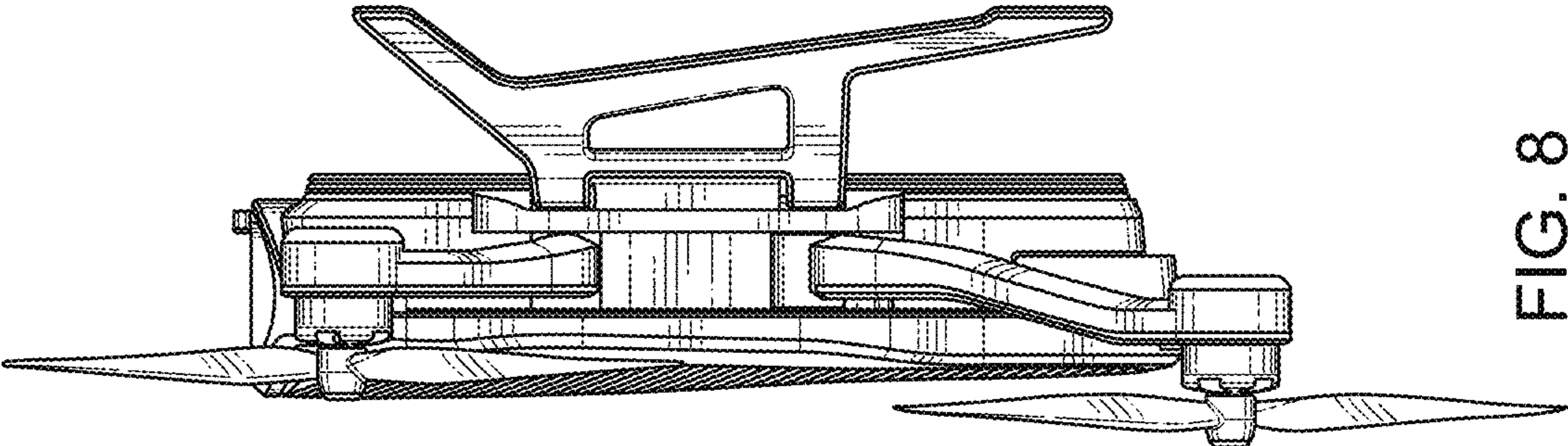

FIG. 8

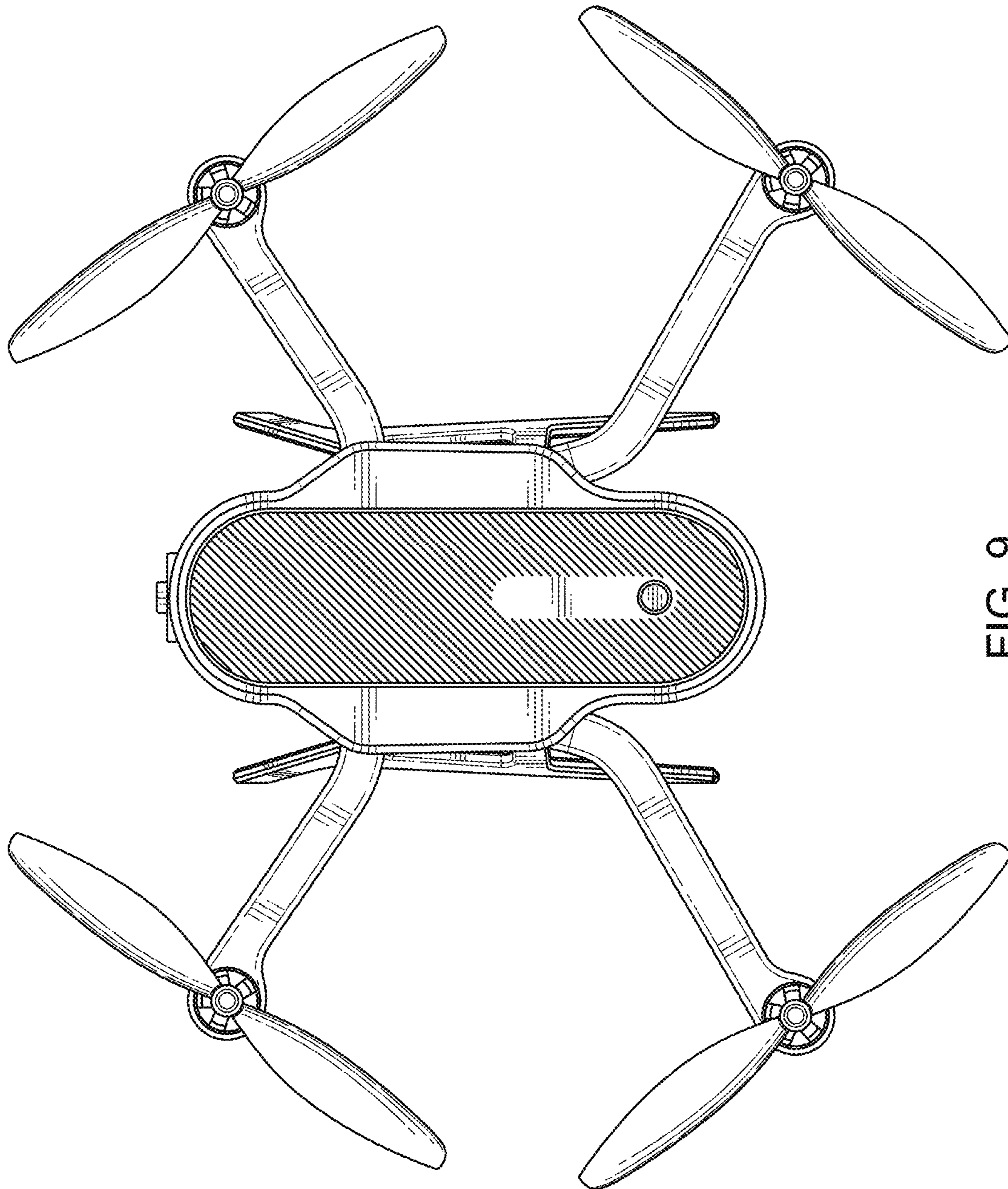

FIG. 9

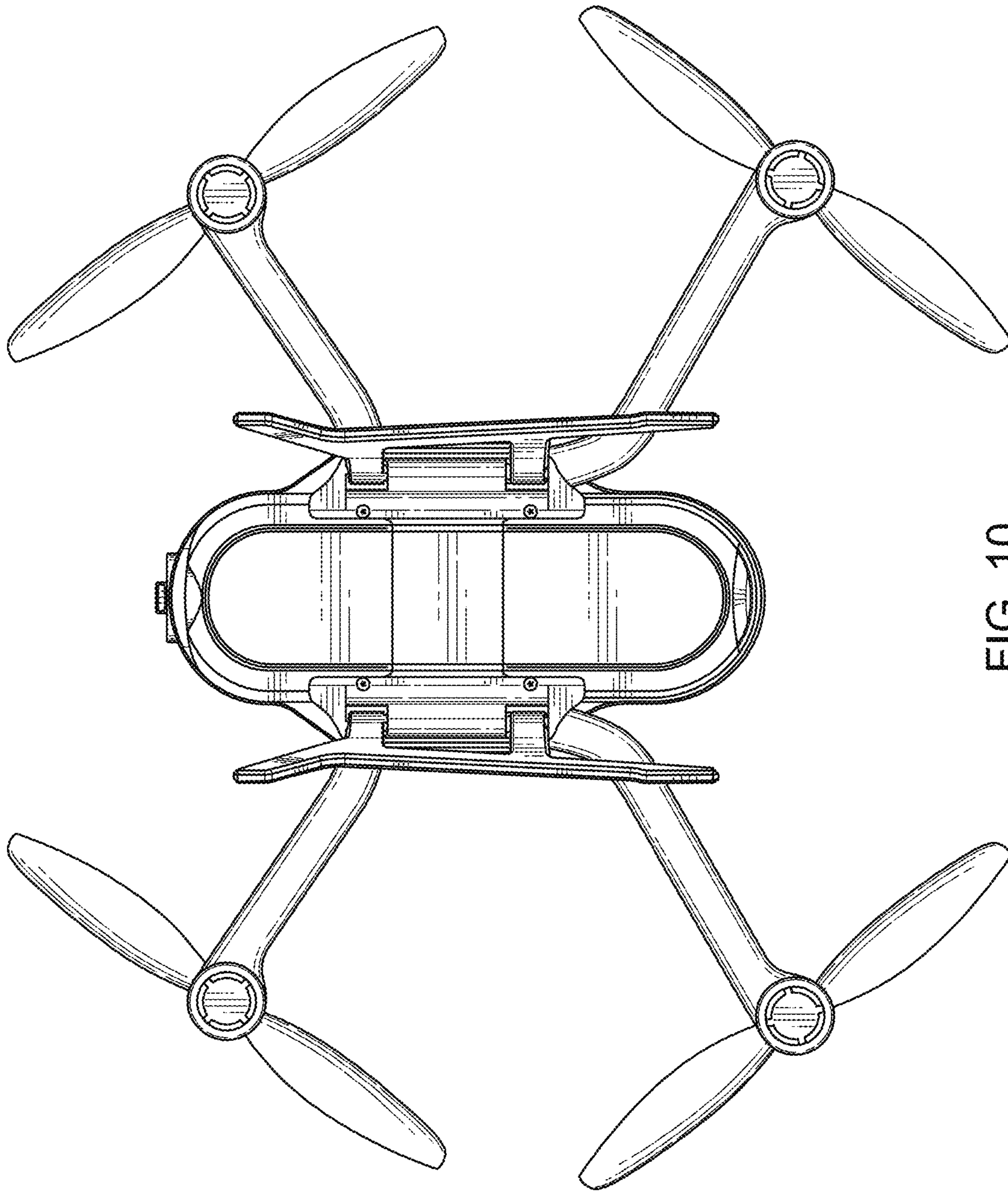

FIG. 10

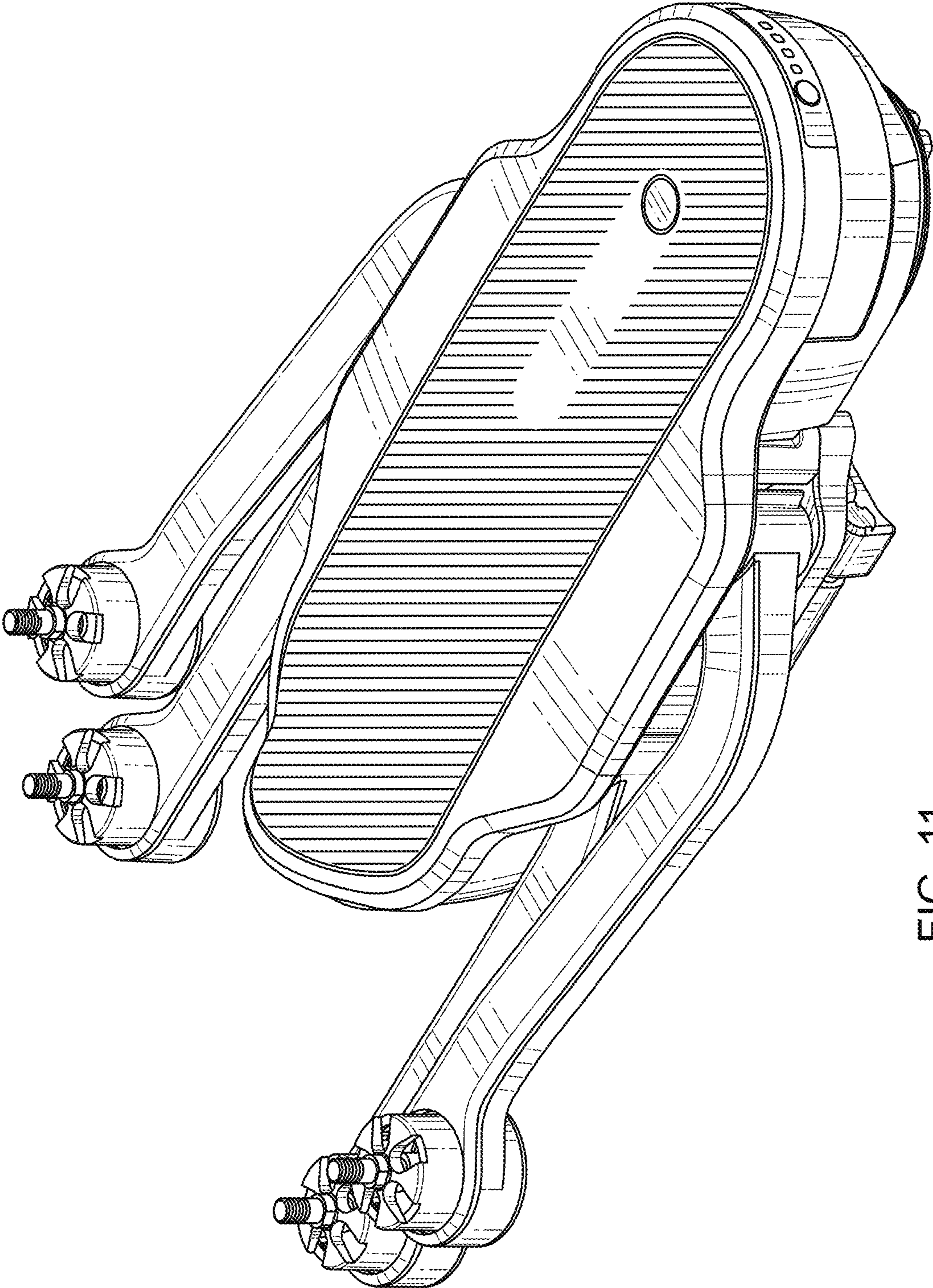

FIG. 11

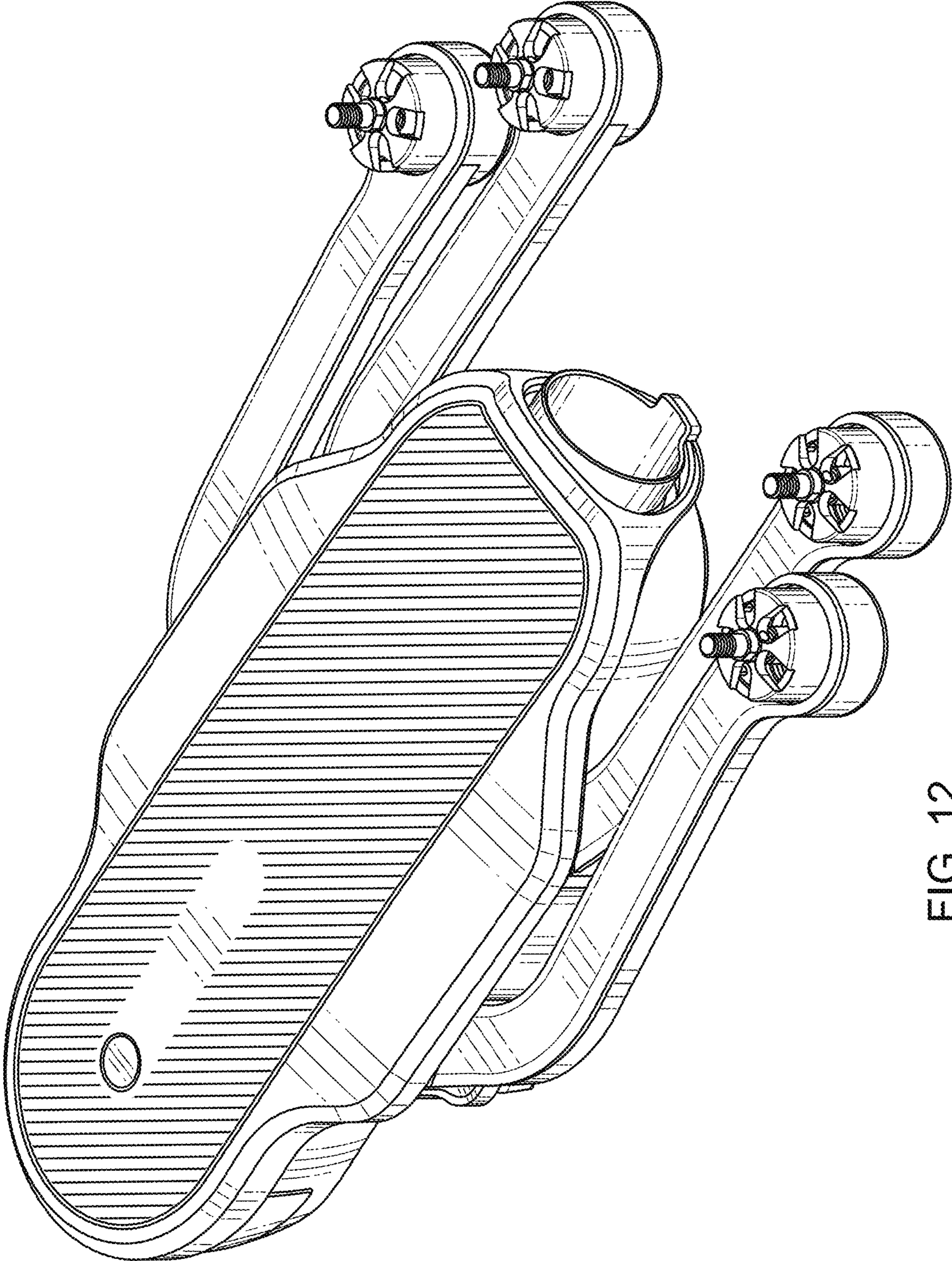

FIG. 12

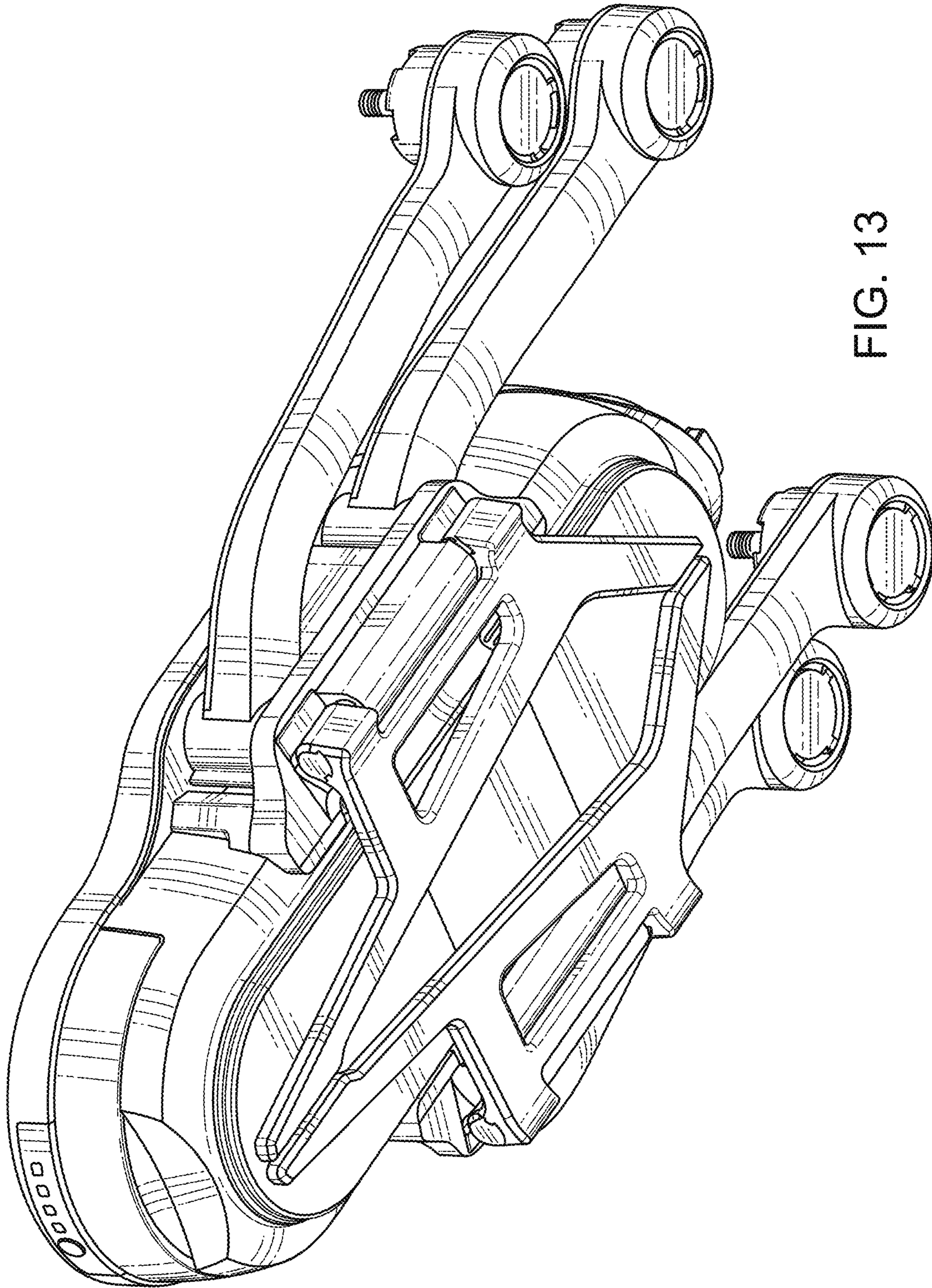

FIG. 13

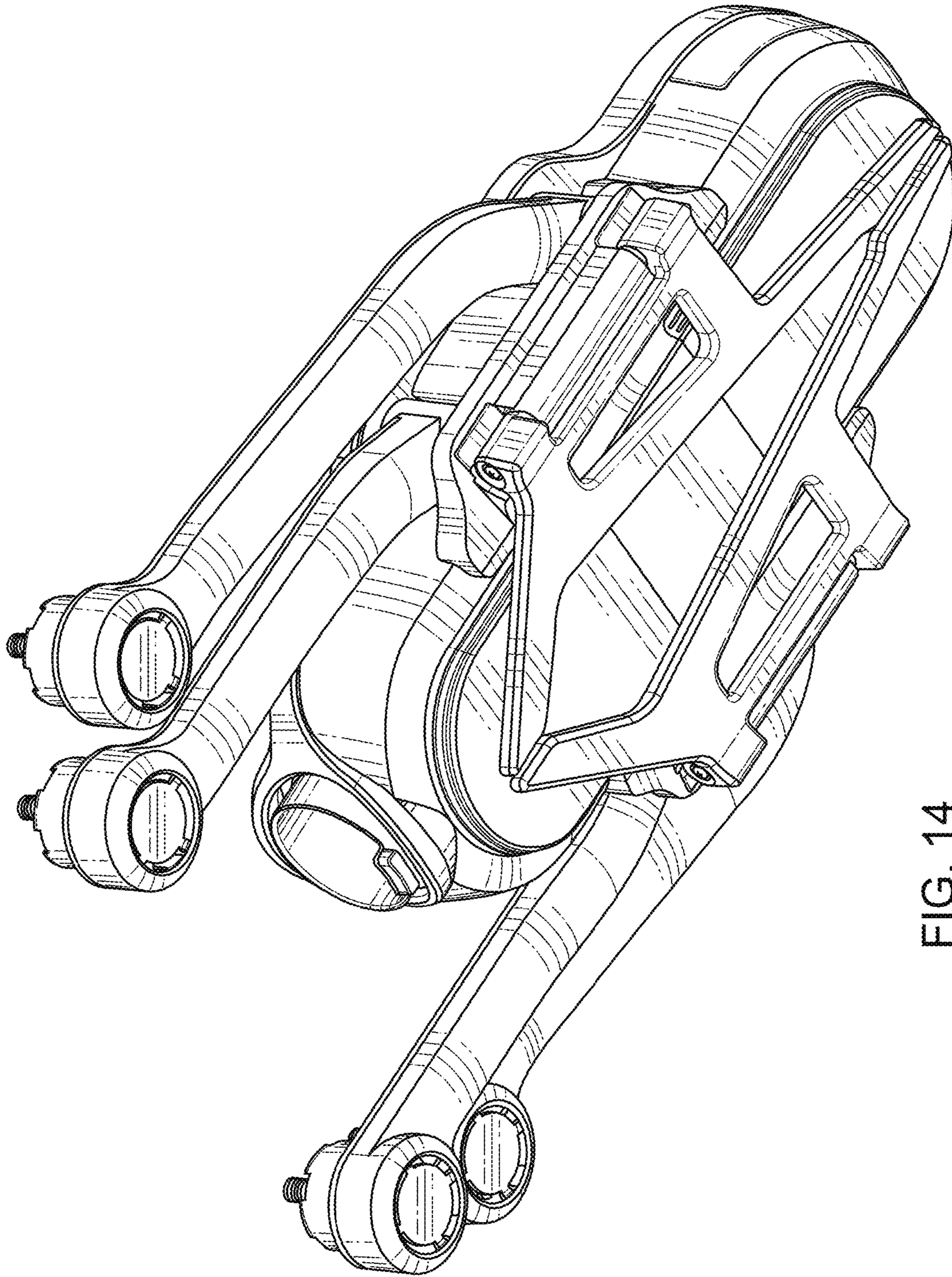

FIG. 14

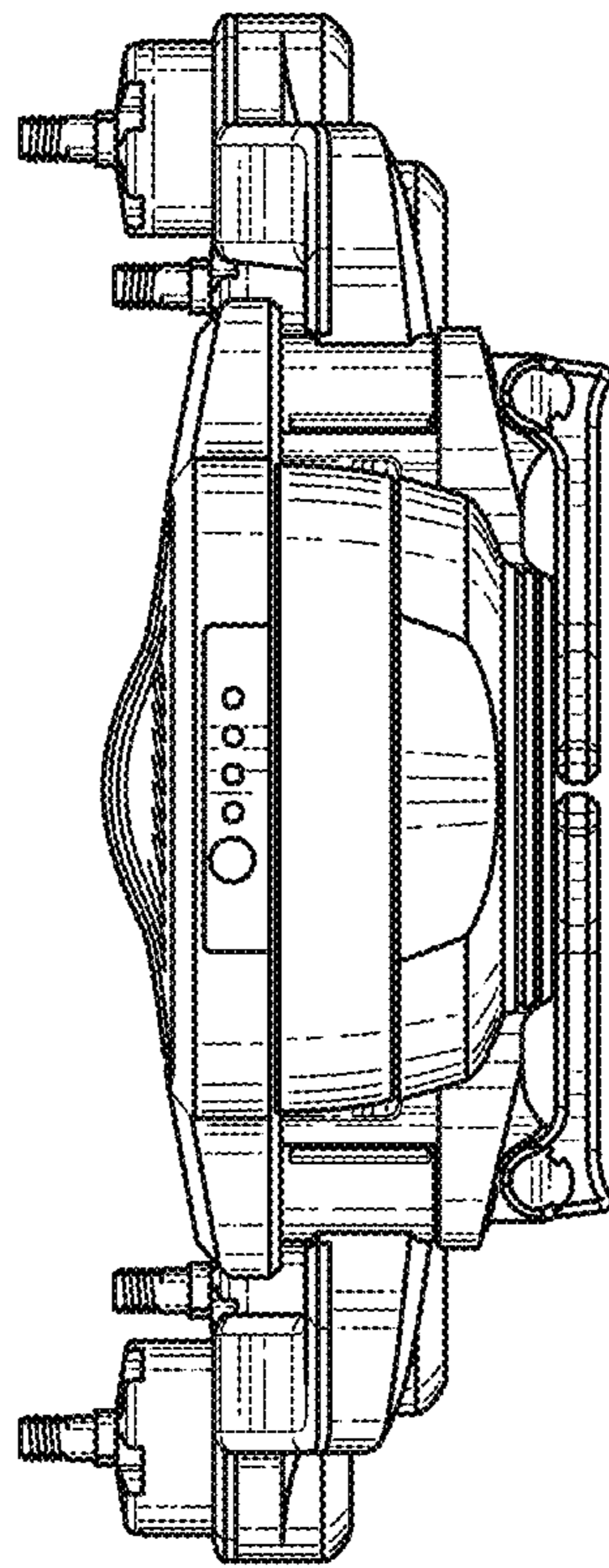

FIG. 15

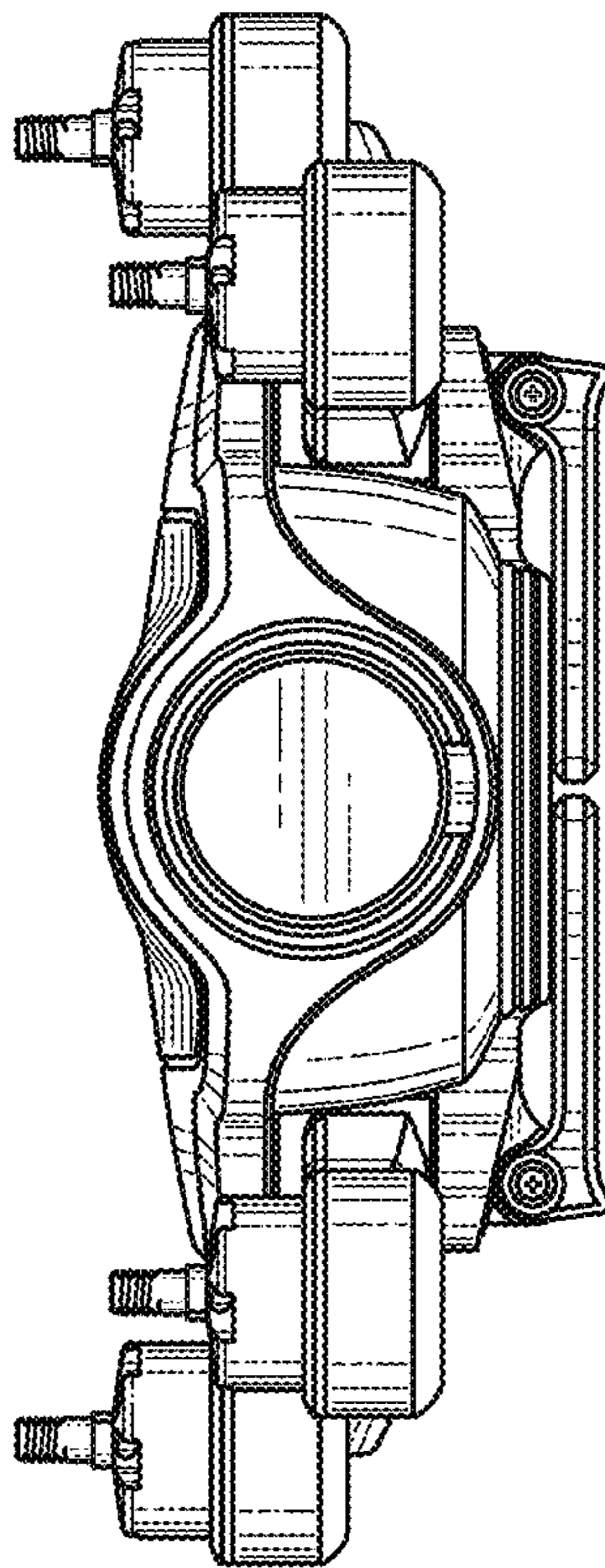

FIG. 16

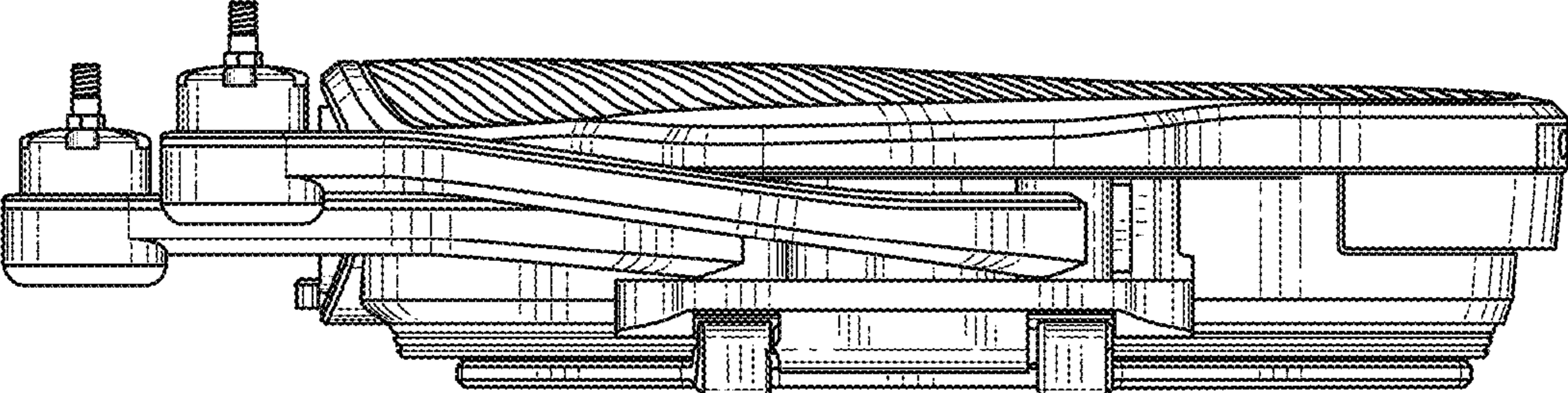

FIG. 17

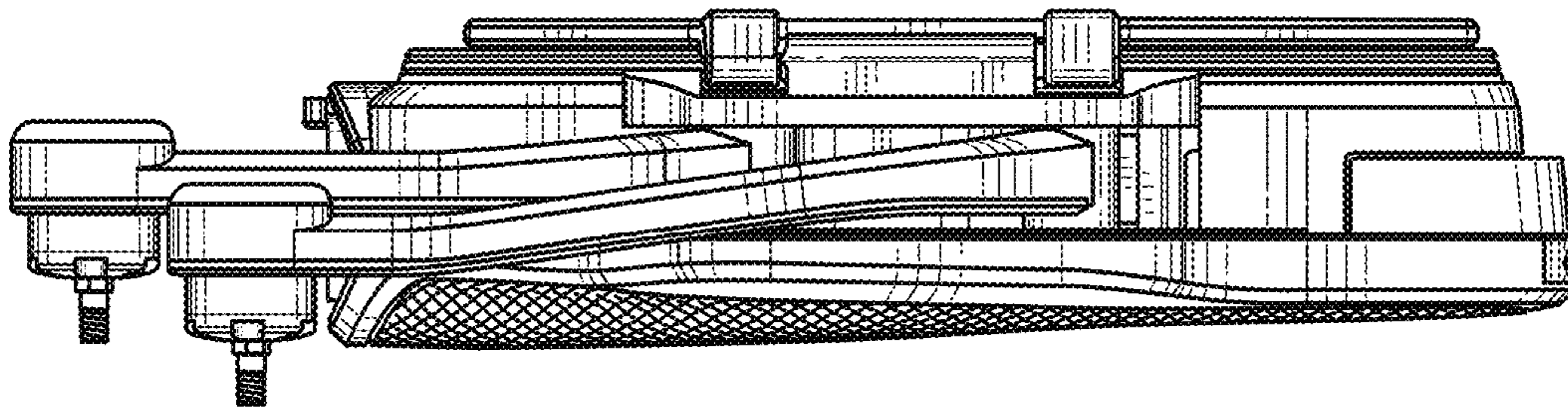

FIG. 18

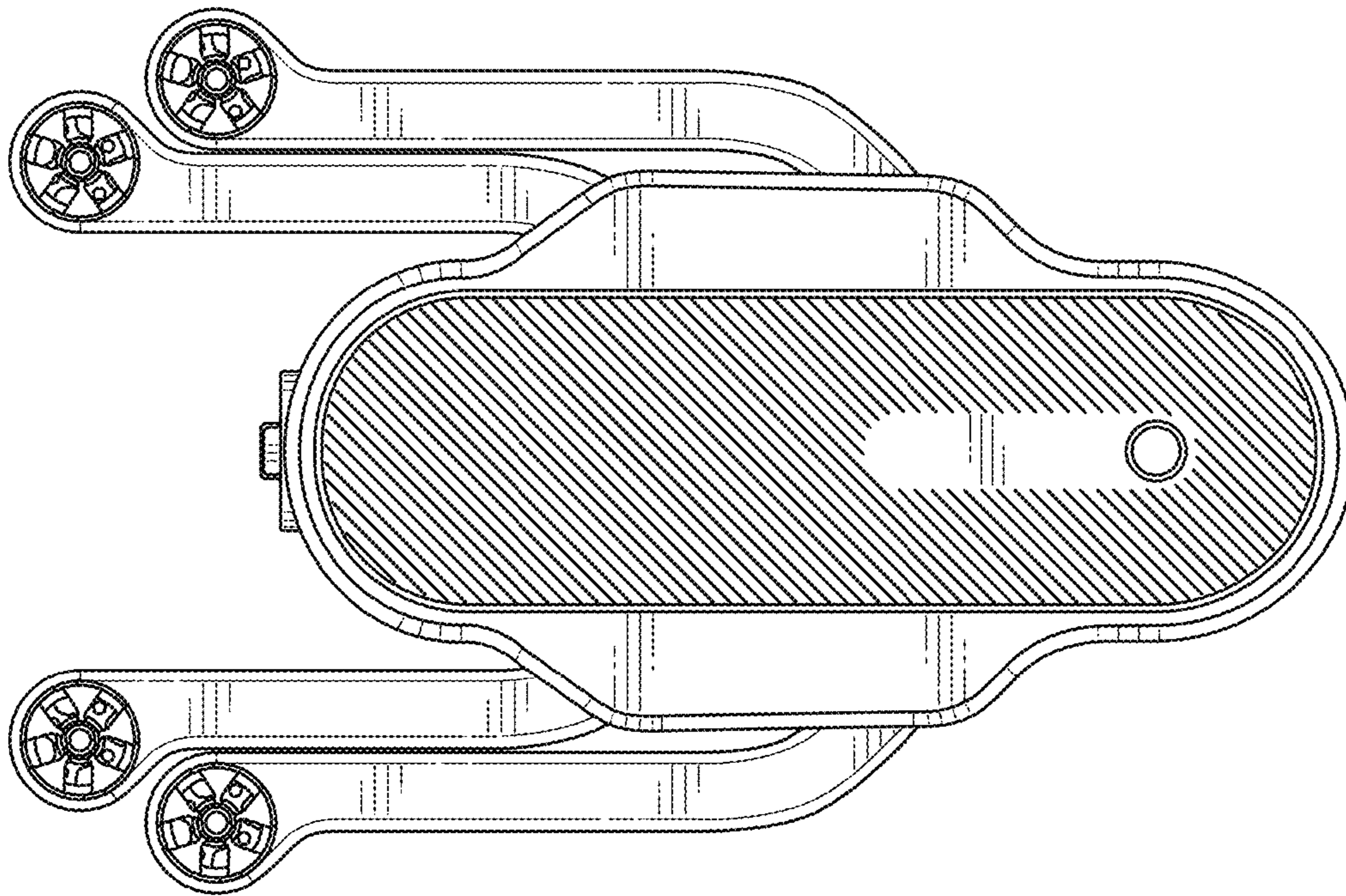

FIG. 19

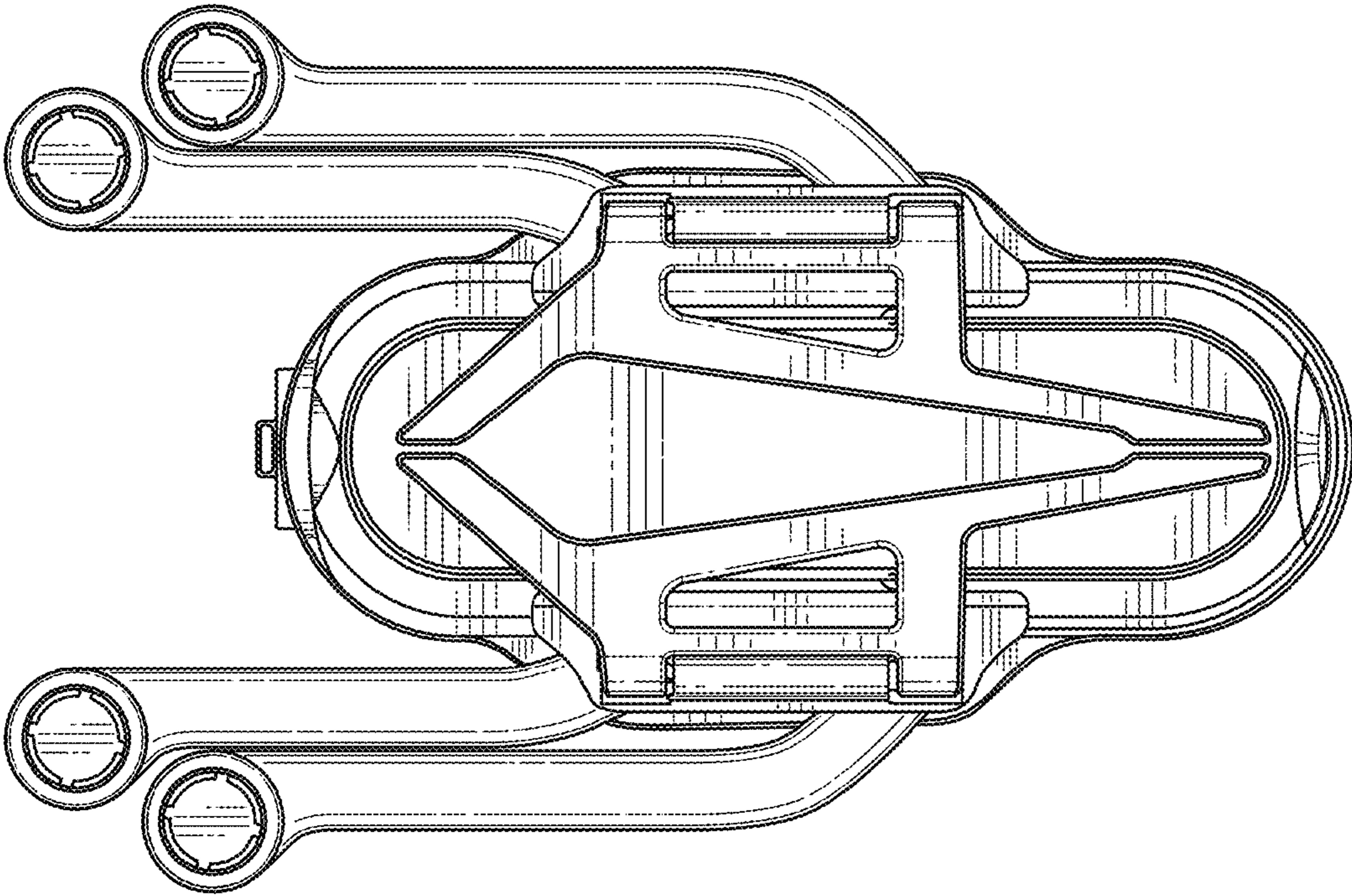

FIG. 20

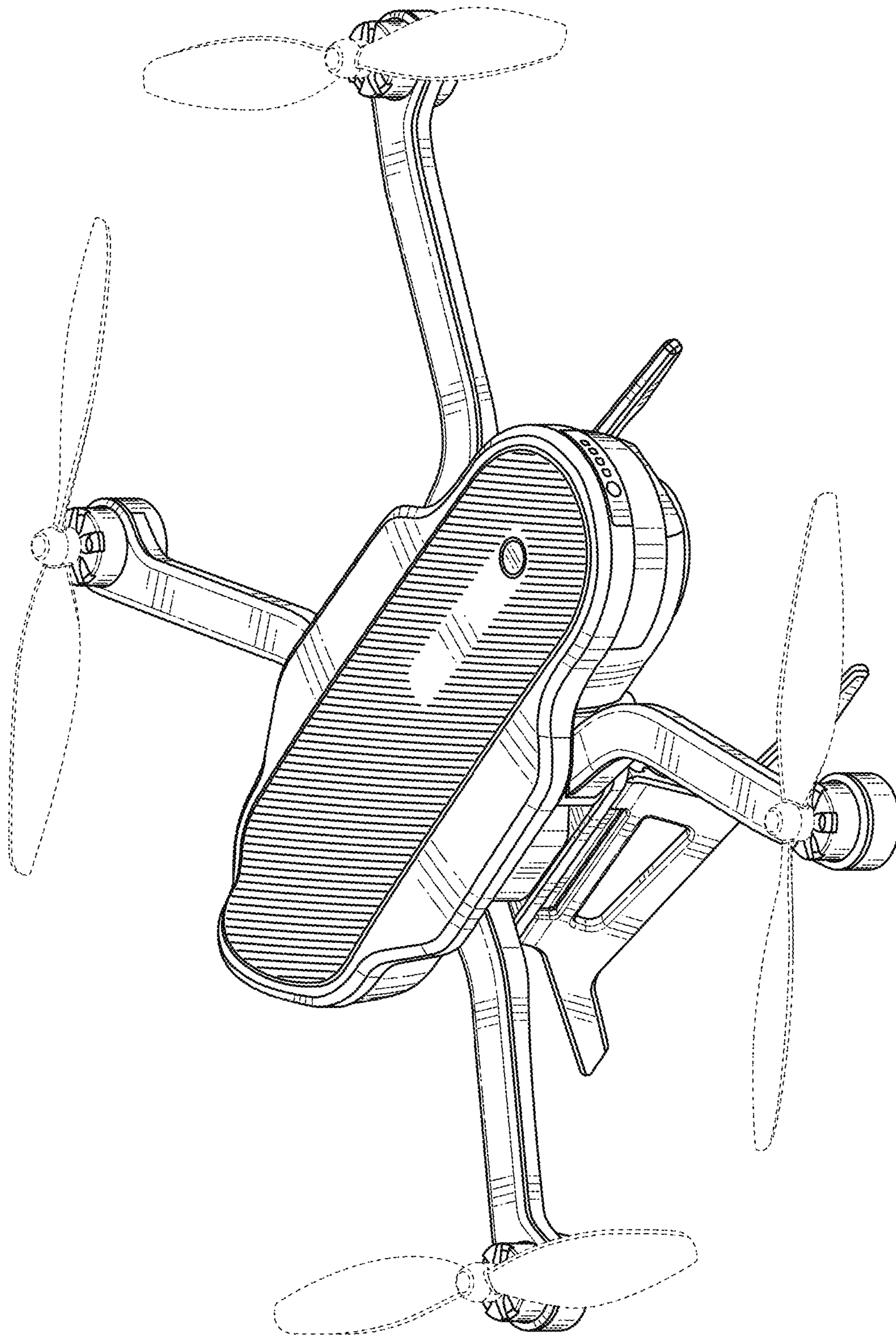

FIG. 21

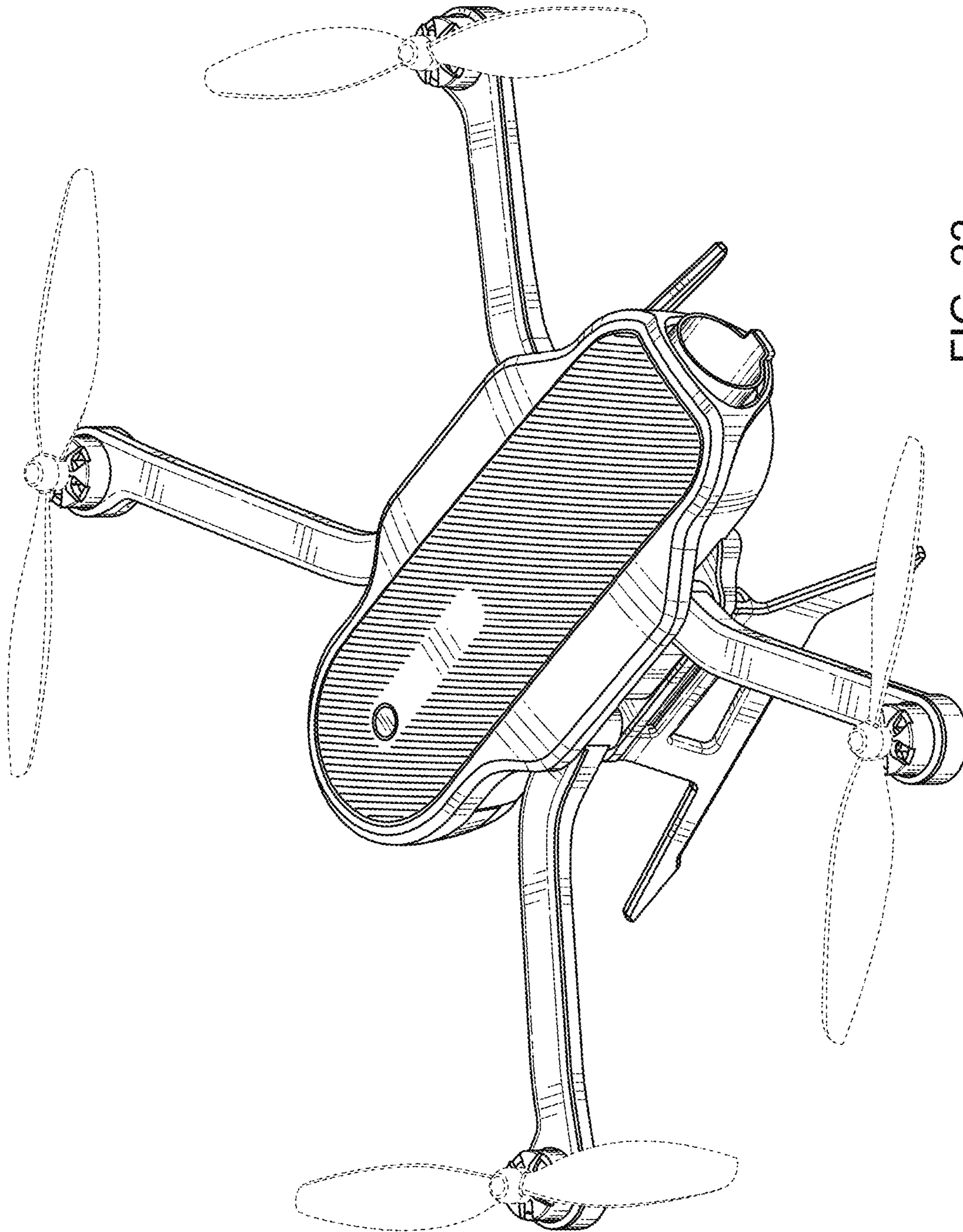

FIG. 22

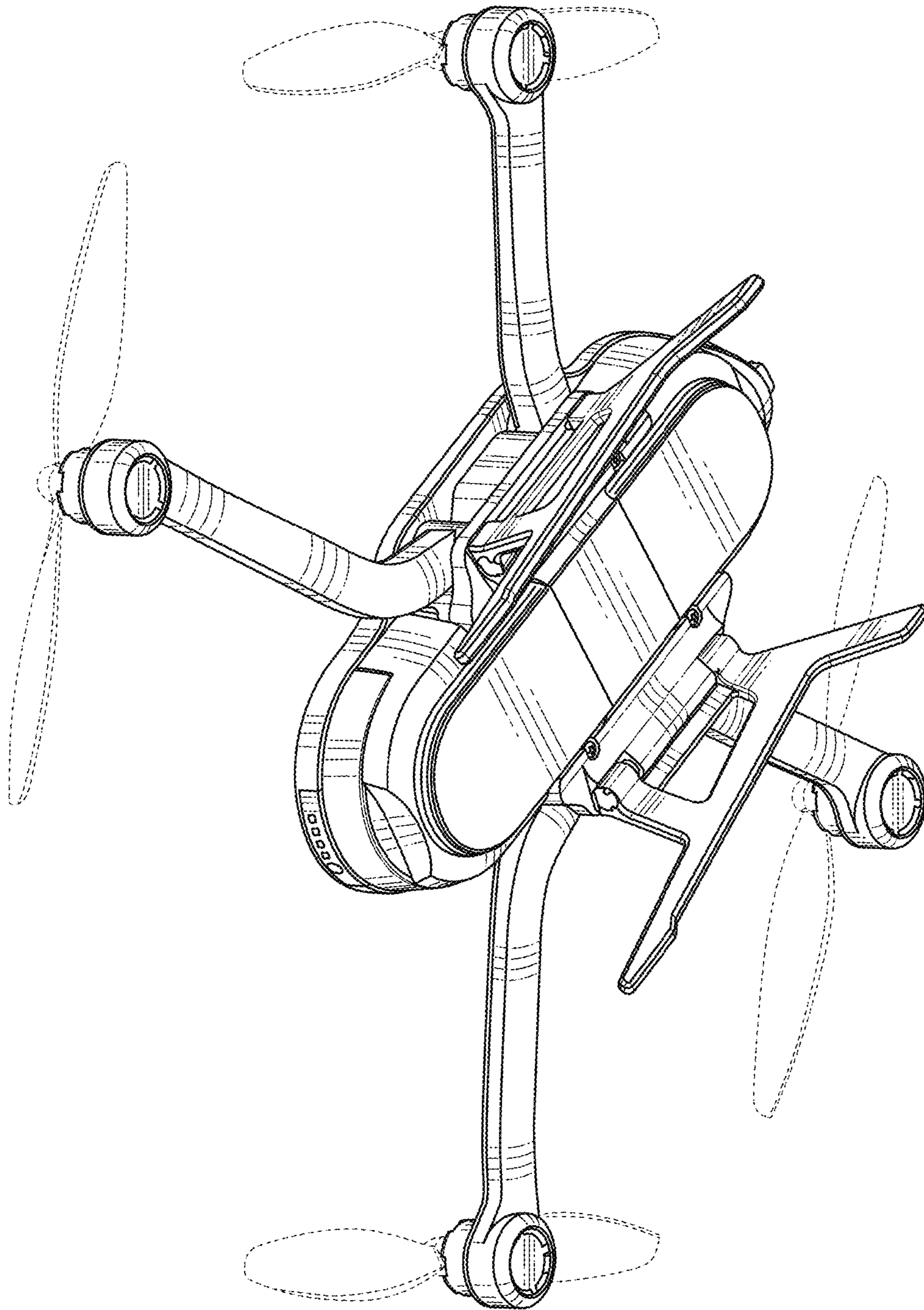

FIG. 23

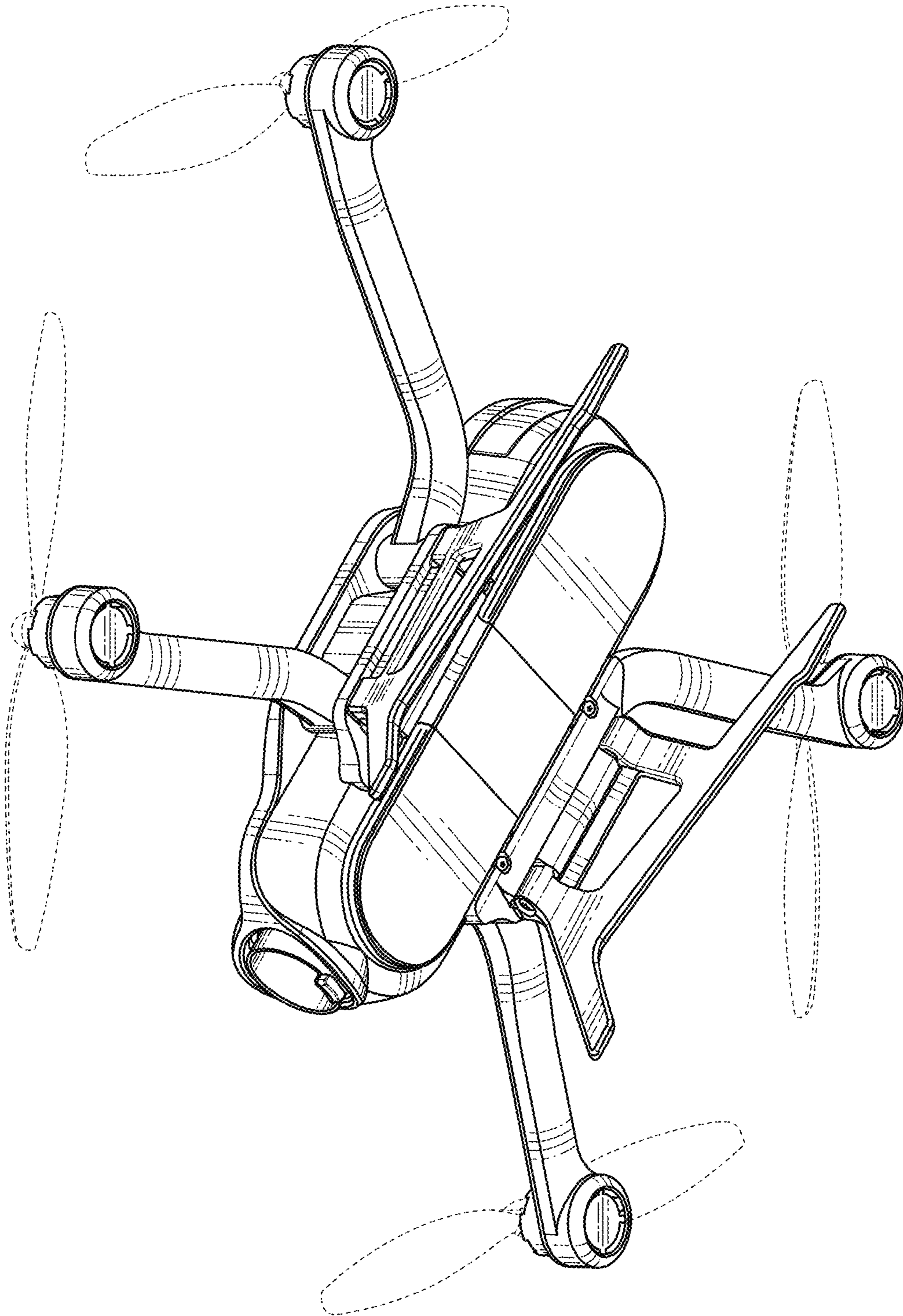

FIG. 24

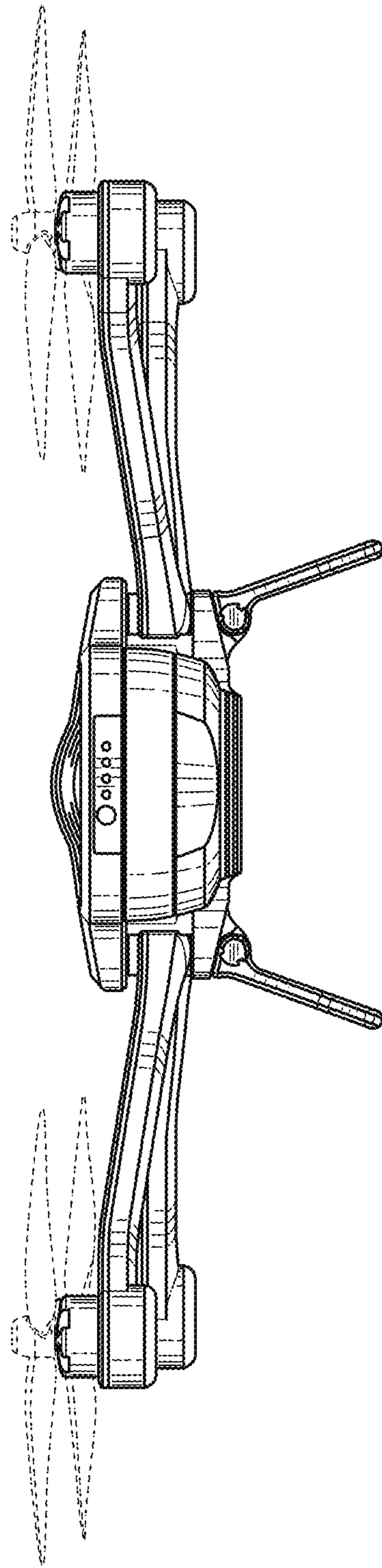

FIG. 25

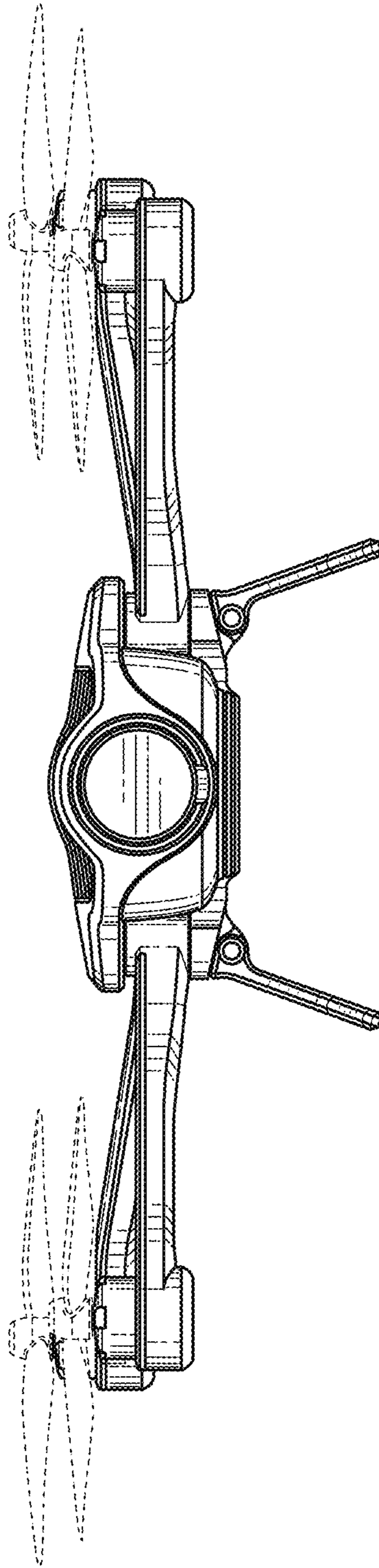

FIG. 26

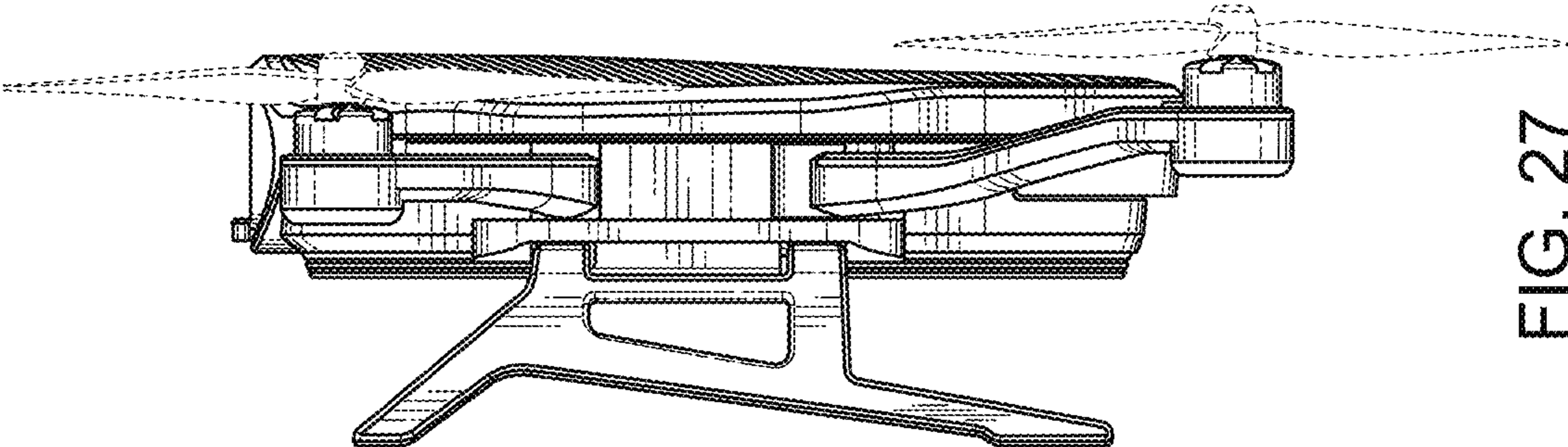

FIG. 27

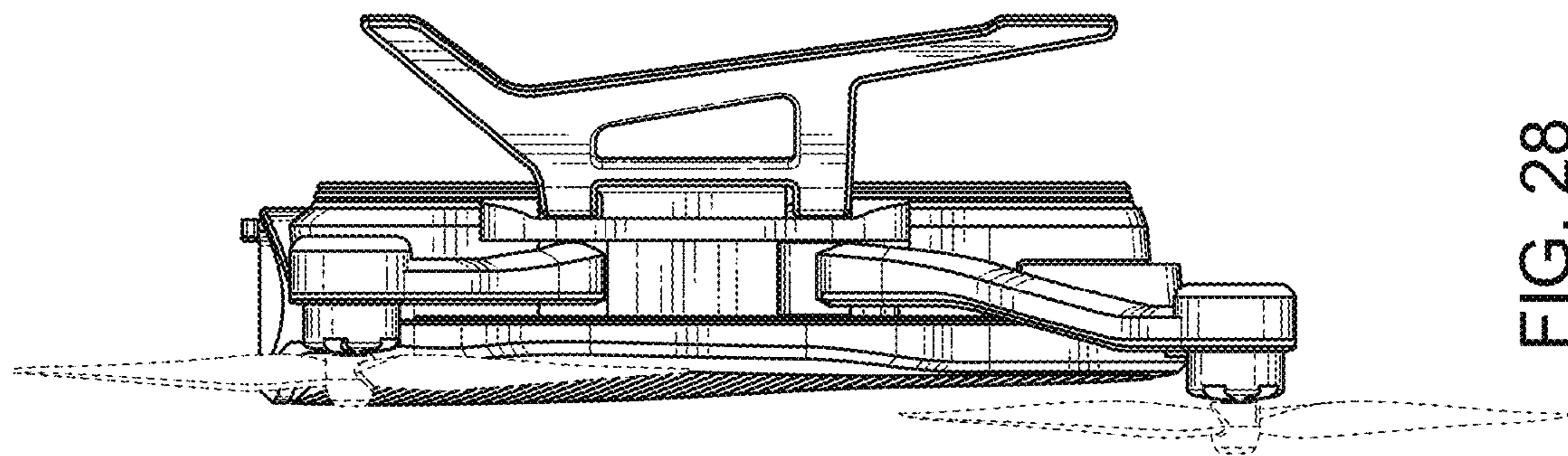

FIG. 28

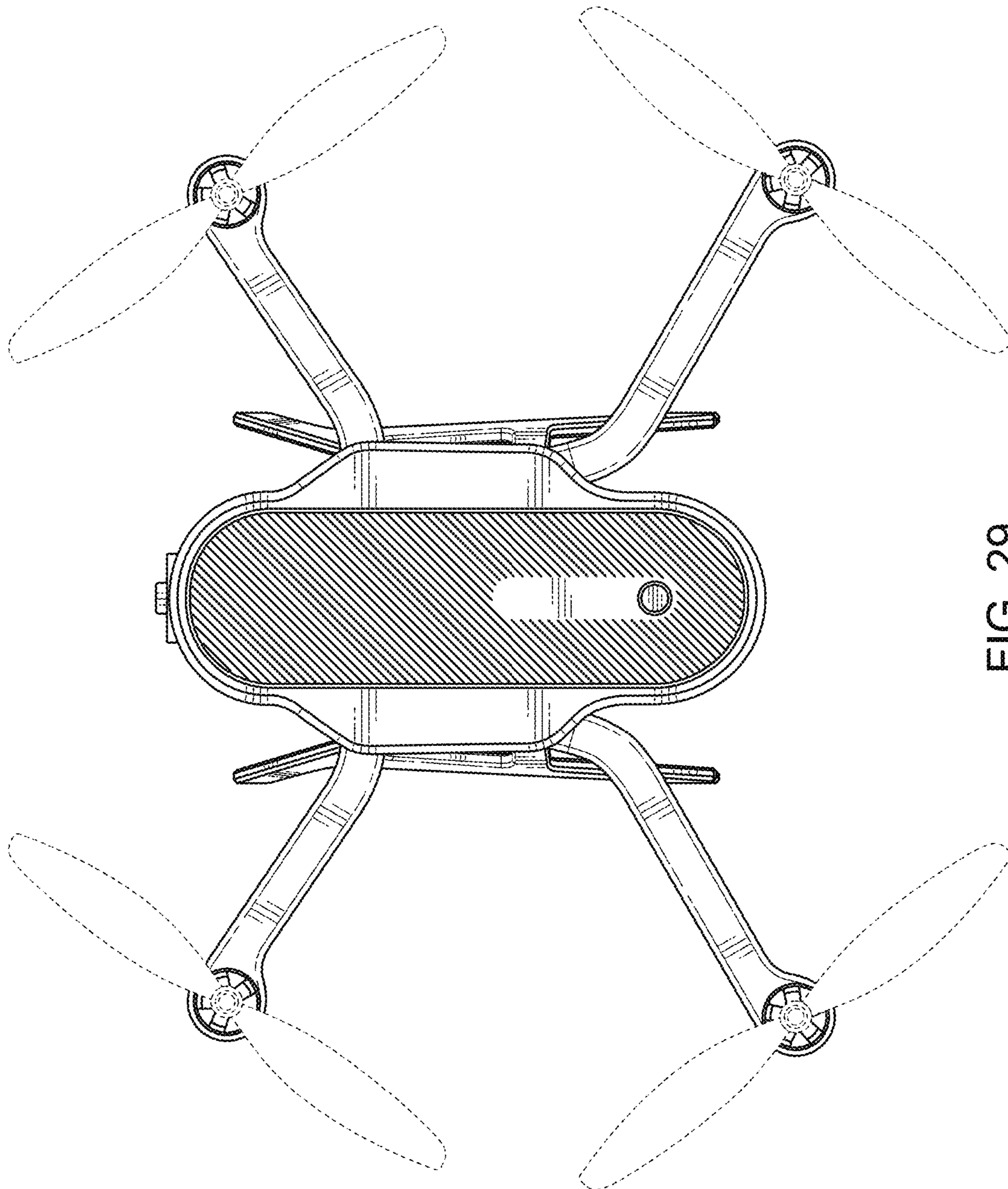

FIG. 29

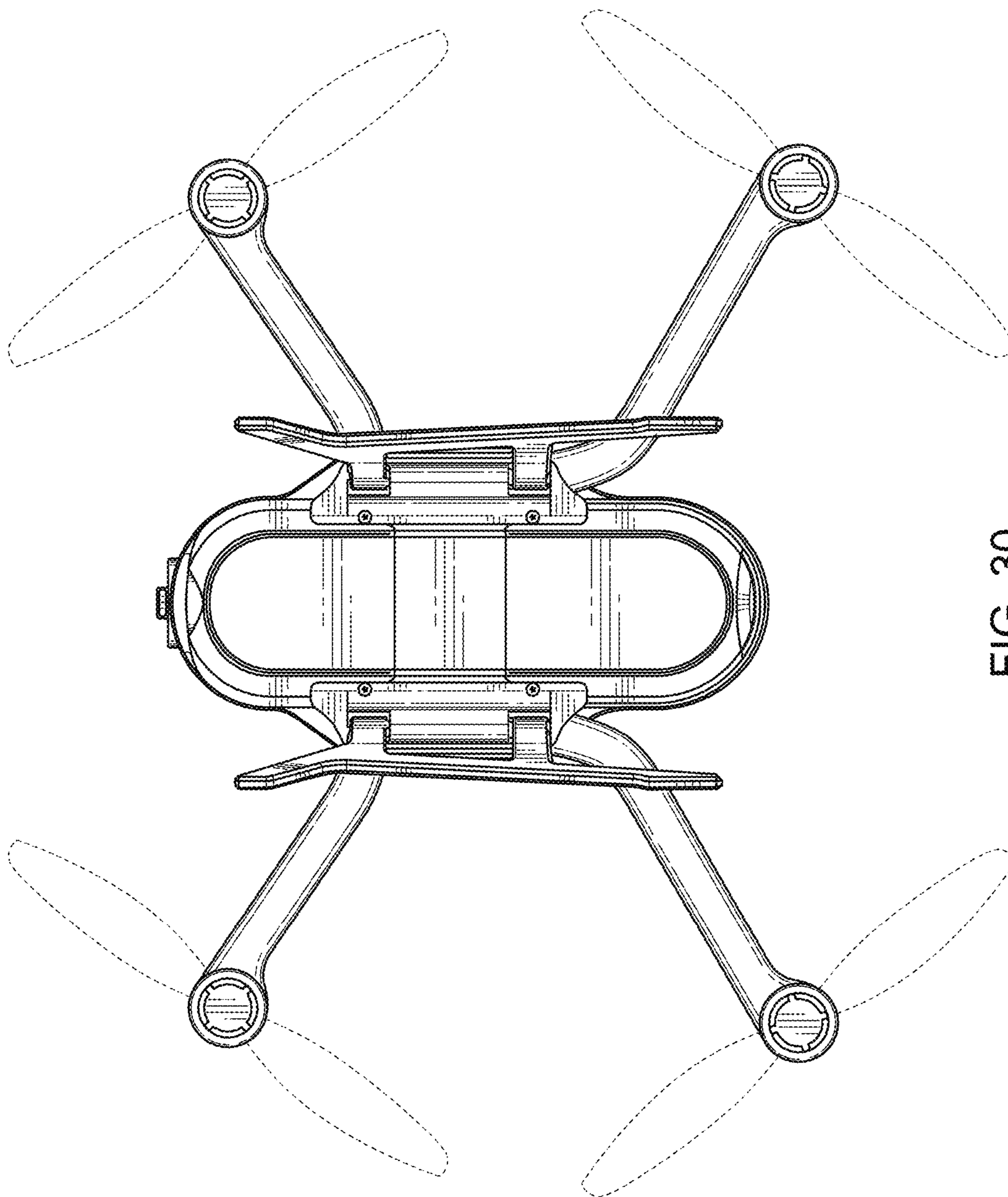

FIG. 30