



US00D768521S

(12) **United States Design Patent** (10) **Patent No.:** **US D768,521 S**
Lisseman (45) **Date of Patent:** **** Oct. 11, 2016**

(54) **VEHICLE OCCUPANT MONITOR**

FOREIGN PATENT DOCUMENTS

(71) Applicant: **TK Holdings Inc.**, Auburn Hills, MI (US)

CN 101494771 7/2009
WO 2012/135018 10/2012

(72) Inventor: **Jason Carl Lisseman**, Shelby Township, MI (US)

OTHER PUBLICATIONS

(73) Assignee: **TK Holdings Inc.**, Auburn Hills, MI (US)

“How Automakers are Fighting ‘Alarm Fatigue’”. Found online Oct. 13, 2015 at www.wired.com. Page dated Feb. 25, 2013. Retrieved from <http://www.wired.com/2013/02/fighting-alarm-fatigue/>.*

(**) Term: **15 Years**

(Continued)

(21) Appl. No.: **29/552,828**

(22) Filed: **Jan. 26, 2016**

Primary Examiner — Robert M Spear
Assistant Examiner — Kendra L Hamilton
(74) *Attorney, Agent, or Firm* — Meunier Carlin & Curfman LLC

Related U.S. Application Data

(62) Division of application No. 29/513,378, filed on Dec. 30, 2014, now Pat. No. Des. 751,437.

(51) **LOC (10) Cl.** **10-05**

(52) **U.S. Cl.**
USPC **D10/104.1; D12/177**

(58) **Field of Classification Search**
USPC D12/175, 176, 177, 223; 74/552, 558, 74/558.5; D11/120; D21/398, 400, 707; 219/202, 204; D10/104.1, 106.6, 106.7
CPC B60N 3/005; A47B 13/02; B62D 1/06; B29C 44/06

See application file for complete search history.

(56) **References Cited**

U.S. PATENT DOCUMENTS

D276,037 S *	10/1984	Montgomery	D12/177
D346,997 S *	5/1994	Kurtis	D12/176
D347,439 S *	5/1994	Vananderoye	D14/299
5,749,744 A	5/1998	Henderson et al.		
5,801,763 A	9/1998	Suzuki		
5,878,156 A	3/1999	Okumura		
D415,442 S	10/1999	Ikeda		
6,097,295 A	8/2000	Griesinger et al.		

(Continued)

(57) **CLAIM**

The ornamental design for a vehicle occupant monitor, as shown and described.

DESCRIPTION

FIG. 1 is a front perspective view of a vehicle occupant monitor, showing my new design.
FIG. 2 is a front elevation view of the vehicle occupant monitor shown in FIG. 1.
FIG. 3 is a rear elevation view of the vehicle occupant monitor shown in FIG. 1.
FIG. 4 is a right side view of the vehicle occupant monitor shown in FIG. 1.
FIG. 5 is a left side view of the vehicle occupant monitor shown in FIG. 1.
FIG. 6 is a top plan view of the vehicle occupant monitor shown in FIG. 1; and,
FIG. 7 is a bottom plan view of the vehicle occupant monitor shown in FIG. 1.
In the drawings, the broken lines depict environmental subject matter only and form no part of the claimed design.

1 Claim, 5 Drawing Sheets

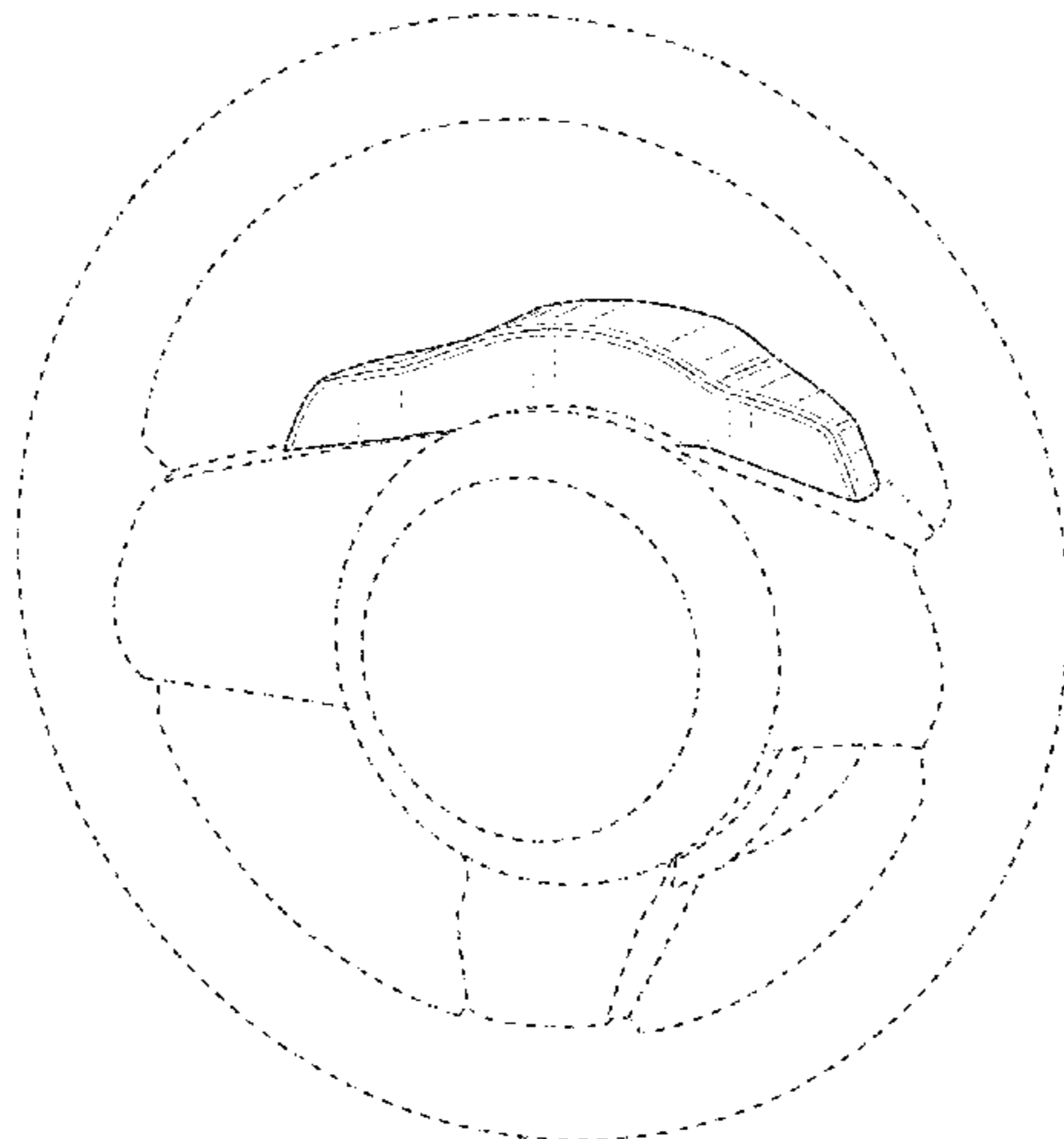

(56)

References Cited

U.S. PATENT DOCUMENTS

D464,595 S * 10/2002 Zorkendorfer D12/176
 6,736,657 B2 5/2004 Bonn
 6,831,993 B2 12/2004 Lemelson et al.
 D502,206 S * 2/2005 Park D17/21
 6,952,498 B2 10/2005 Ishikura
 6,989,754 B2 1/2006 Kisacanin et al.
 7,138,922 B2 11/2006 Strumolo et al.
 D571,244 S 6/2008 Barrantes
 7,423,540 B2 9/2008 Kisacanin
 7,427,924 B2 9/2008 Ferrone et al.
 7,450,016 B2 11/2008 Isaji et al.
 7,522,752 B2 4/2009 Adachi et al.
 7,570,785 B2 8/2009 Breed
 7,580,545 B2 8/2009 Venkatesh et al.
 7,592,920 B2 9/2009 Kopf et al.
 7,596,242 B2 9/2009 Breed et al.
 7,663,495 B2 2/2010 Haque et al.
 7,686,337 B2 * 3/2010 Myers B62D 1/16
 280/779
 D613,217 S * 4/2010 Schowalter D12/177
 7,777,778 B2 8/2010 Scharenbroch et al.
 7,791,491 B2 9/2010 Johns
 7,826,964 B2 11/2010 Lee et al.
 D628,523 S * 12/2010 Daniel D12/177
 7,853,051 B2 12/2010 Ota
 7,868,771 B2 1/2011 Yamada et al.
 8,063,972 B2 11/2011 Chiu
 8,144,992 B2 3/2012 Koumura
 8,152,198 B2 4/2012 Breed et al.
 D661,211 S 6/2012 Hou
 D666,934 S * 9/2012 Krumpe D10/106.6
 8,300,891 B2 10/2012 Chen et al.
 D670,628 S * 11/2012 Tasaki D12/176
 8,314,707 B2 11/2012 Kobetski et al.
 8,340,368 B2 12/2012 Lee
 8,384,555 B2 2/2013 Rosen
 8,391,554 B2 3/2013 Lee et al.
 D680,459 S 4/2013 Corso
 8,435,188 B2 5/2013 Ohue et al.
 8,457,364 B2 6/2013 Hiroshi
 8,482,626 B2 7/2013 Chen et al.
 8,548,209 B2 10/2013 Lung
 8,587,440 B2 11/2013 Weng et al.
 8,599,027 B2 12/2013 Sanchez
 8,698,639 B2 4/2014 Fung et al.
 8,724,858 B2 5/2014 Kawakubo
 8,783,132 B2 7/2014 Neumann et al.
 D710,270 S 8/2014 Kanki
 D713,277 S 9/2014 Hasegawa
 8,823,826 B2 9/2014 Chen et al.
 8,824,739 B2 9/2014 Hiramaki
 8,830,318 B2 9/2014 Diehl et al.
 8,902,070 B2 12/2014 Kobetski et al.
 D737,709 S 9/2015 Hulan
 D751,437 S * 3/2016 Lisseman D10/104.1
 2003/0045133 A1 3/2003 Hirschfeld et al.
 2003/0067148 A1 4/2003 Keutz
 2003/0209893 A1 11/2003 Breed et al.
 2005/0131607 A1 6/2005 Breed
 2005/0185383 A1 8/2005 Petrella et al.

2006/0208169 A1 9/2006 Breed et al.
 2008/0062291 A1 3/2008 Sako et al.
 2010/0002075 A1 1/2010 Jung et al.
 2010/0043588 A1 2/2010 Fukawatase
 2010/0083787 A1 * 4/2010 Buchheit B62D 1/187
 74/493
 2011/0153160 A1 6/2011 Hesselting et al.
 2012/0169503 A1 7/2012 Wu et al.
 2012/0242819 A1 9/2012 Schamp
 2013/0216144 A1 8/2013 Robinson et al.
 2013/0286204 A1 10/2013 Cheng
 2014/0093133 A1 4/2014 Frank et al.
 2014/0313333 A1 10/2014 Le et al.
 2015/0367875 A1 * 12/2015 Nonoyama B62D 1/065
 219/204

OTHER PUBLICATIONS

“Monitor System Steers Drivers Clear of Accidents”. Found online Oct. 13, 2015 at www.wired.com. Page dated May 8, 2007. Retrieved from http://www.wired.com/2007/05/monitor_system_/.*
 “Don’t Get Hurt, Stay Alert”. Found online Apr. 21, 2016 at densodynamics.com. Page dated Oct. 13, 2013. Retrieved from <http://web.archive.org/web/20131013221342/http://www.densodynamics.com/dont-get-hurt-stay-alert-with-densos-driver-status-monitor>.*
 “Ford and Health Industry Collaborate on Concept System”. Found online Apr. 21, 2016 at blog.caranddriver.com. Page dated May 19, 2011. Retrieved from <http://blog.caranddriver.com/ford-and-health-industry-collaborate-on-concept-system-to-monitor-your-health-in-your-car/>.*
 “How Automakers are Fighting ‘Alarm Fatigue’,” Found online Oct. 13, 2015 at www.wired.com. Page dated Feb. 25, 2013. Retrieved from <http://www.wired.com/2013/02/fighting-alarm-fatigue/>.
 “Monitor System Steers Drivers Clear Accidents,” Found online Oct. 13, 2015 at www.wired.com. Page dated May 8, 2007. Retrieved from http://www.wired.com/2007/05/monitor_system_/.
 International Search Report and Written Opinion, dated Mar. 11, 2016, received in connection with International Patent Application No. PCT/US2015/066246.
 International Search Report and Written Opinion, dated Feb. 11, 2016, received in connection with International Patent Application No. PCT/US2015/066247.
 International Search Report and Written Opinion, dated Mar. 3, 2016, received in connection with International Patent Application No. PCT/US2015/066245.
 Office Action received in U.S. Appl. No. 14/586,124, dated Mar. 23, 2016.
 Co-pending U.S. Appl. No. 14/586,224, filed Dec. 20, 2014 (Issued on Mar. 15, 2016 as D751,437) and its file history.
 Co-pending U.S. Appl. No. 14/586,224, filed Dec. 20, 2014 and its file history.
 Co-pending U.S. Appl. No. 14/586,124, filed Dec. 30, 2014 and its file history.
 Co-pending U.S. Appl. No. 14/586,188, filed Dec. 30, 2014 and its file history.

* cited by examiner

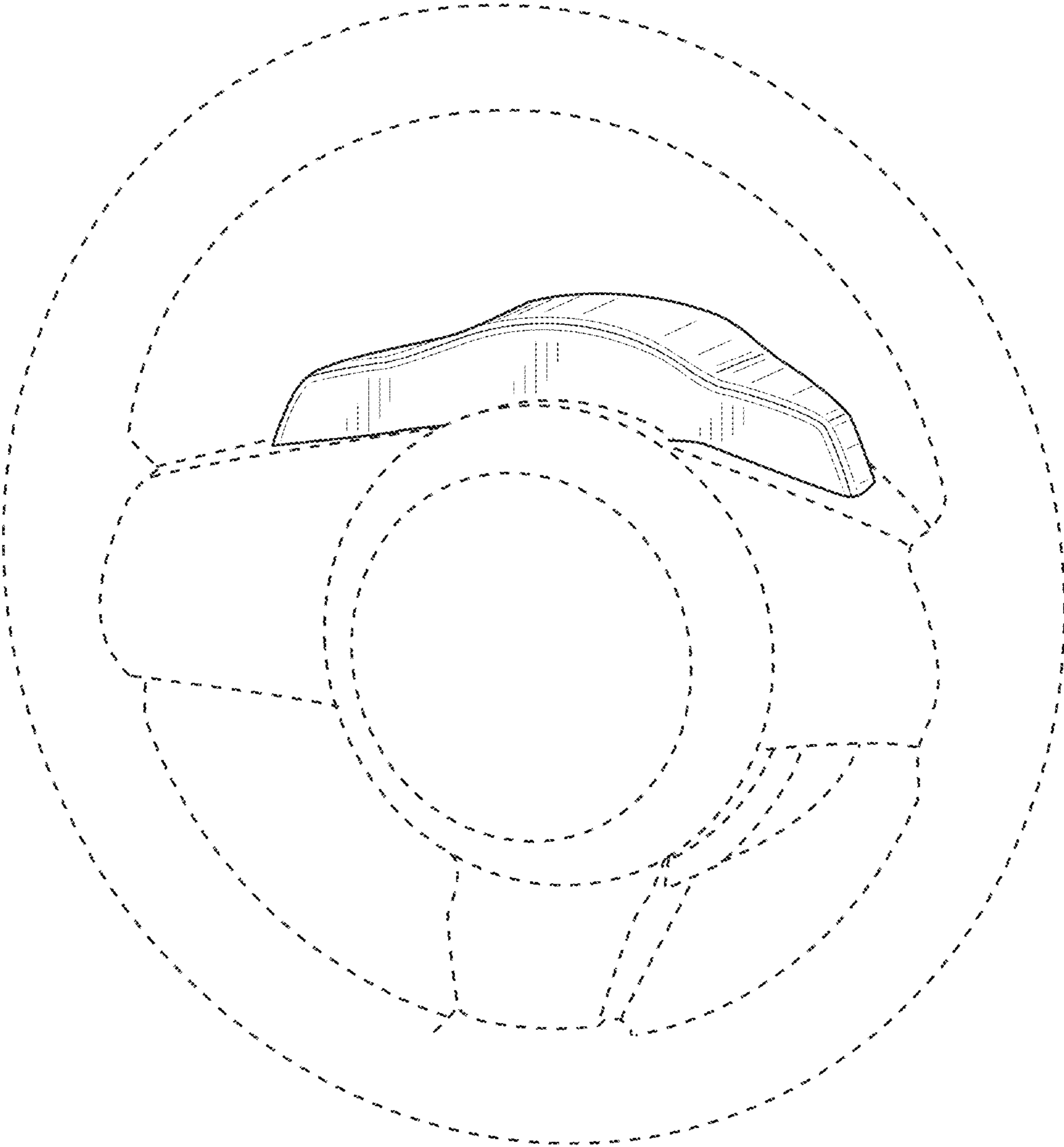

FIG. 1

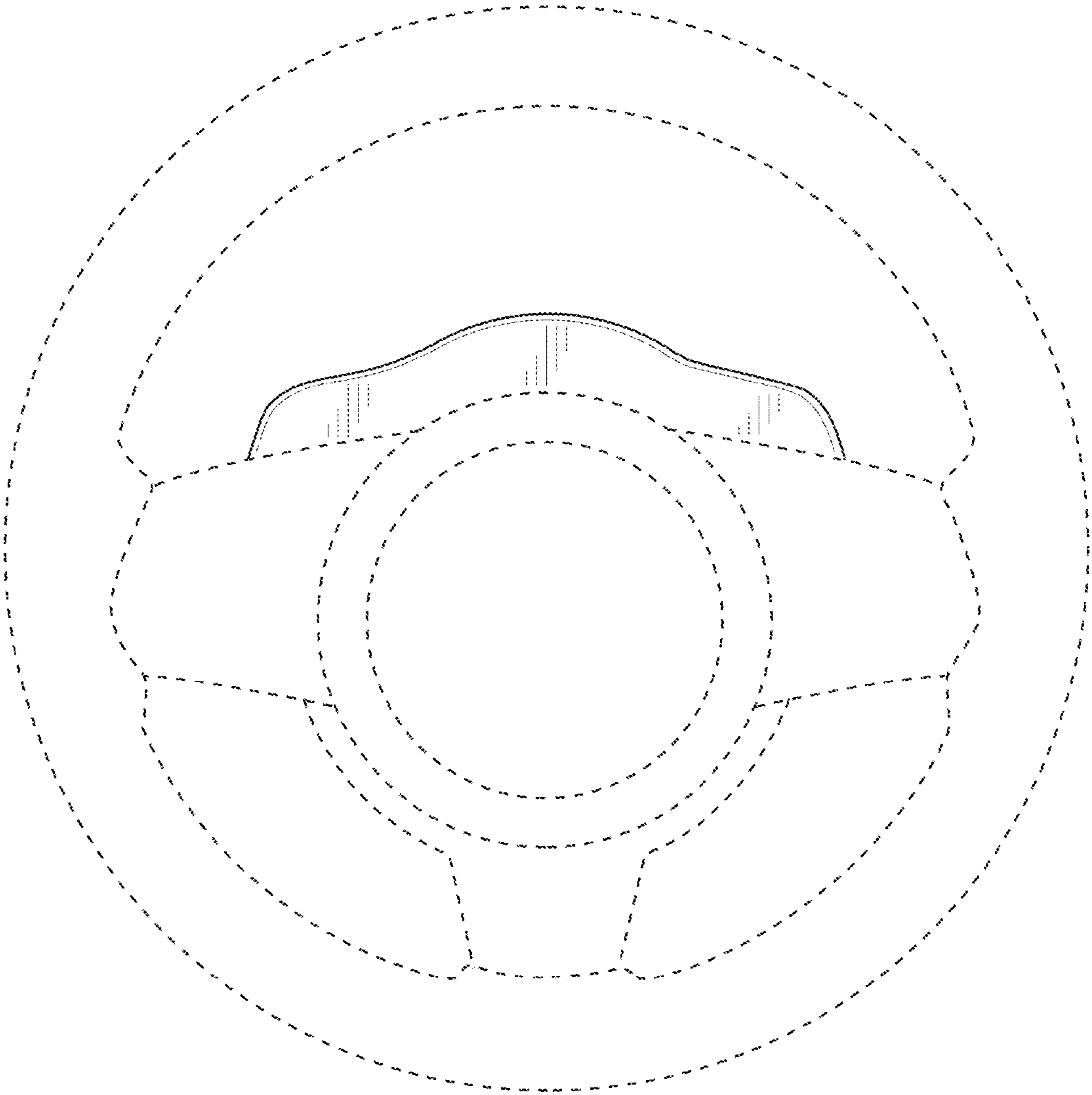

FIG. 2

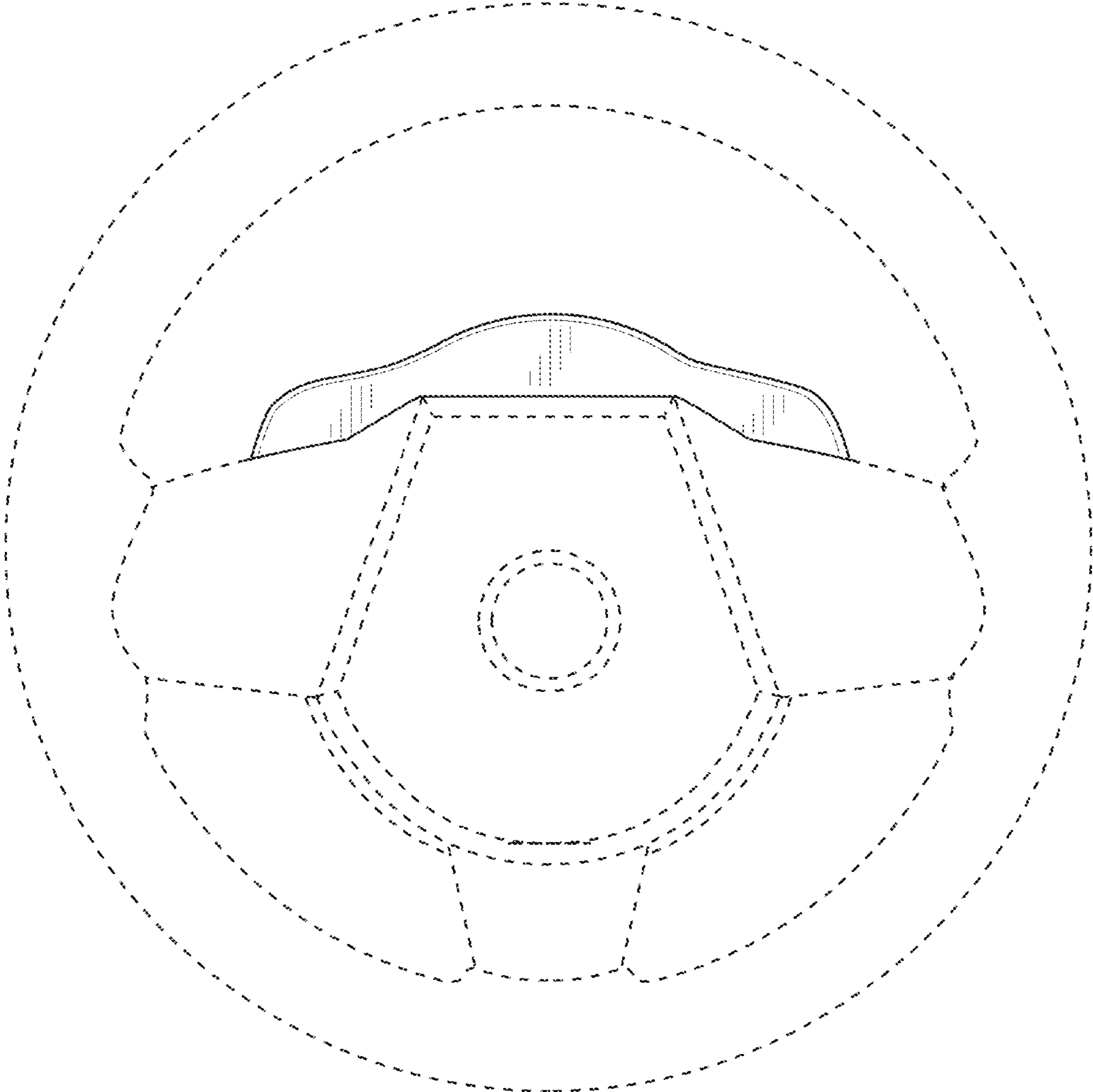

FIG. 3

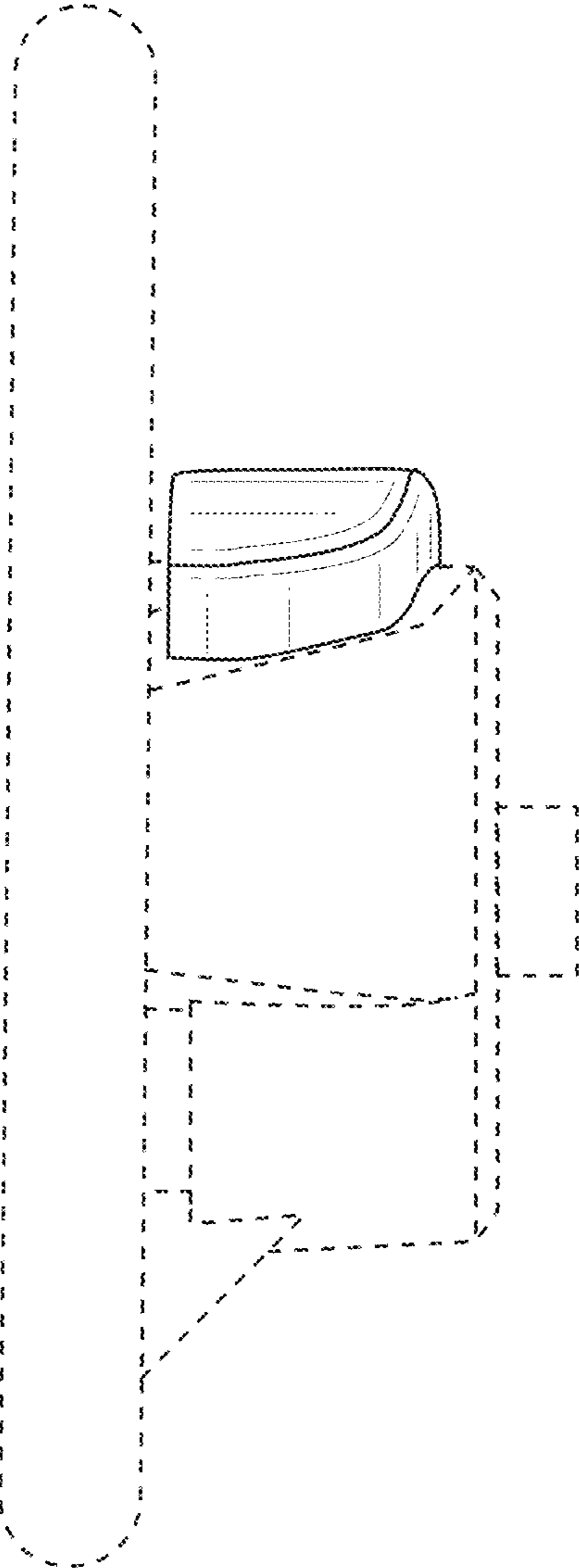

FIG. 4

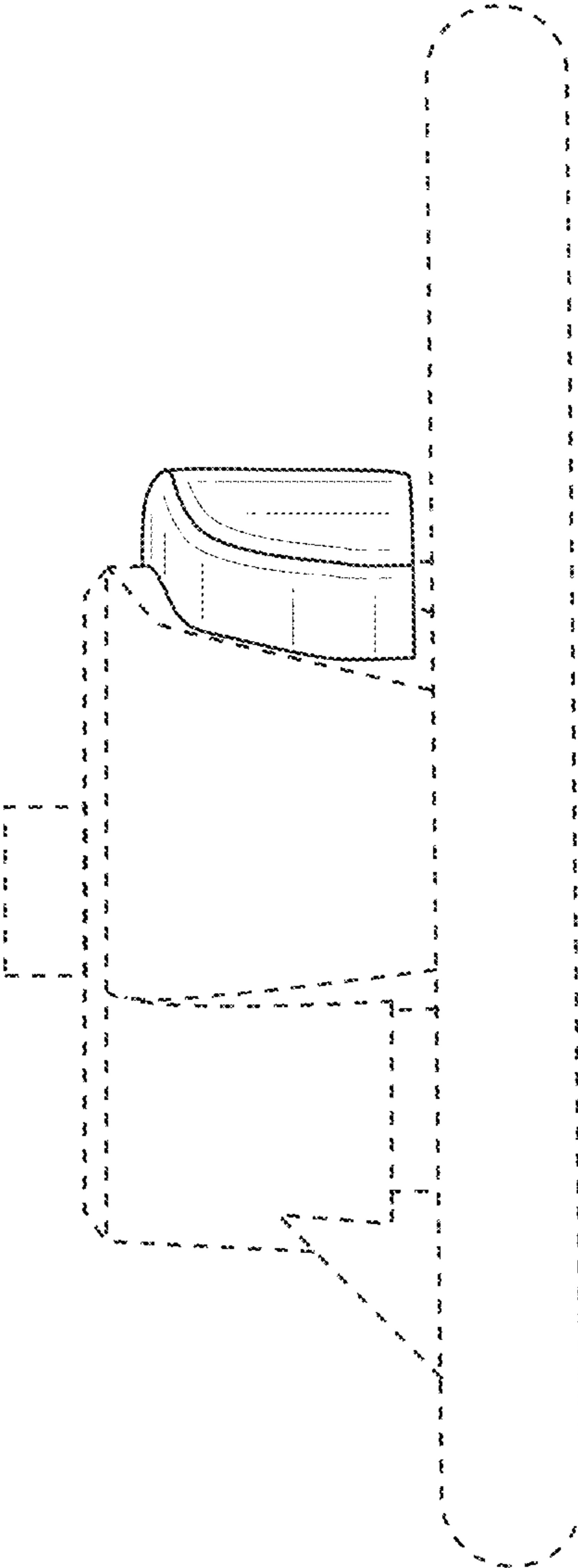

FIG. 5

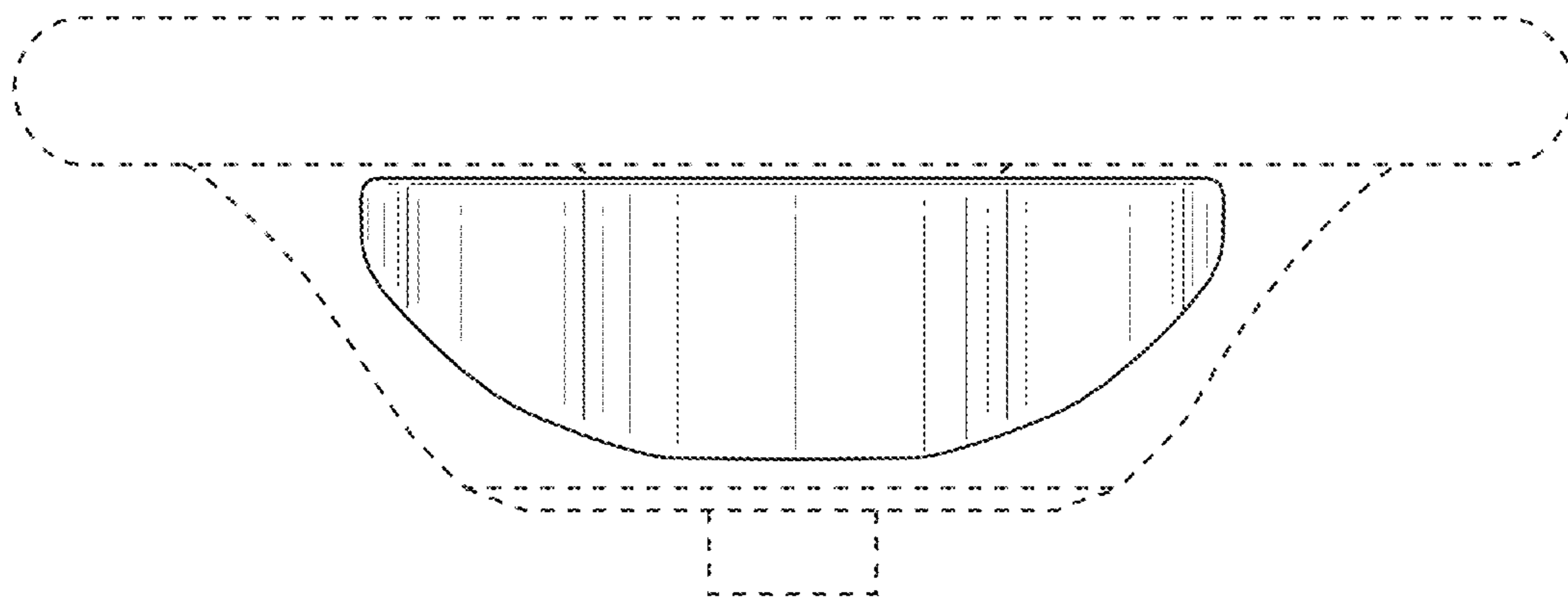

FIG. 6

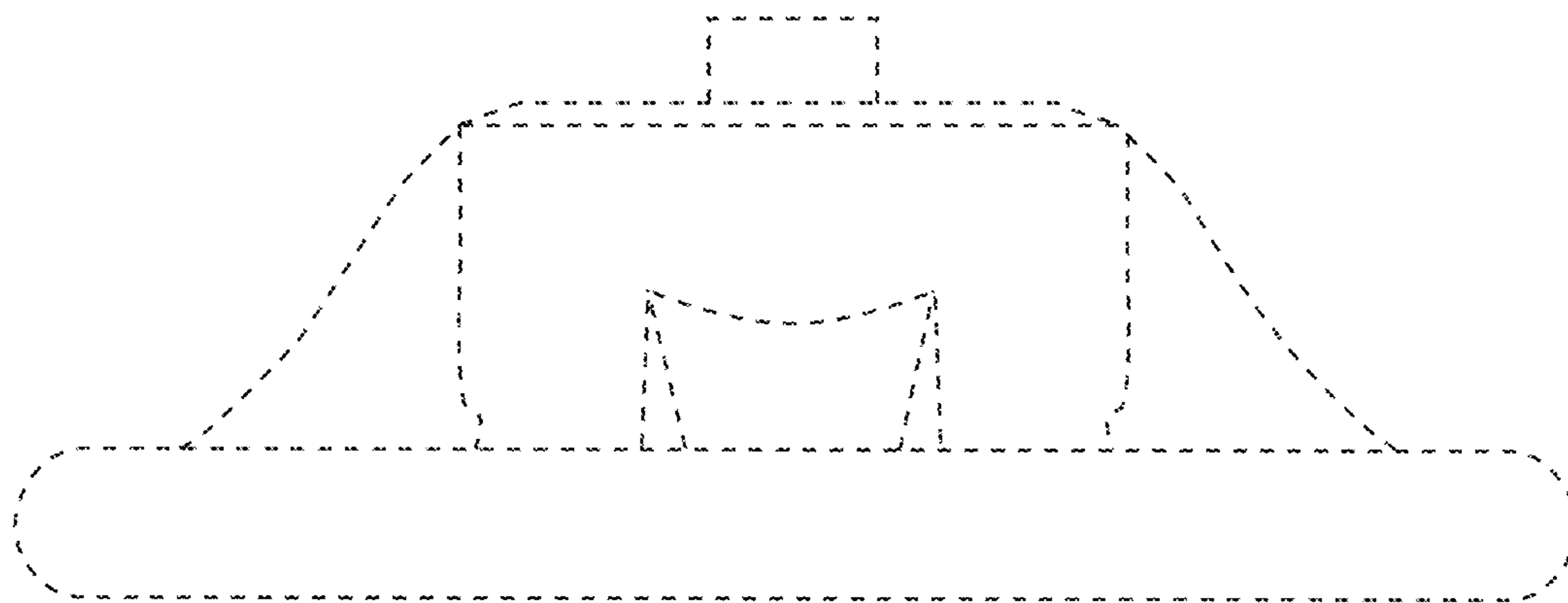

FIG. 7