

US00D768216S

(12) **United States Design Patent** (10) **Patent No.:** **US D768,216 S**
Funakoshi et al. (45) **Date of Patent:** **** Oct. 4, 2016**

(54) **CASTING MACHINE**

FOREIGN PATENT DOCUMENTS

(71) Applicant: **Sintokogio, Ltd.**, Nagoya-shi, Aichi (JP)

JP H9-225622 A 9/1997
JP 2003-205359 A 7/2003

(Continued)

(72) Inventors: **Yukiyoshi Funakoshi**, Toyokawa (JP);
Keishiro Kaneda, Toyokawa (JP);
Katsuhito Sato, Toyokawa (JP)

OTHER PUBLICATIONS

(73) Assignee: **SINTOKOGIO, LTD**, Nagoya-shi, Aichi (JP)

International Bureau of WIPO, Search Report in WO Patent Application No. PCT/JP2015/066787, mailed Aug. 25, 2015 (see listing of references on p. 4; second page of PCT/ISA/210).

(**) Term: **15 Years**

Primary Examiner — Patricia Palasik

(21) Appl. No.: **29/537,303**

(74) *Attorney, Agent, or Firm* — Leydig, Voit & Mayer

(22) Filed: **Aug. 25, 2015**

(57) **CLAIM**

(30) **Foreign Application Priority Data**

The ornamental design for a casting machine, as shown and described.

Feb. 25, 2015 (JP) D2015-003919

(51) **LOC (10) Cl.** **15-09**

(52) **U.S. Cl.**
USPC **D15/135**

(58) **Field of Classification Search**
USPC D15/122, 135, 136, 137
See application file for complete search history.

DESCRIPTION

(56) **References Cited**

U.S. PATENT DOCUMENTS

D153,578 S * 5/1949 Bohannon D15/135
3,170,203 A * 2/1965 Harrison B22D 17/14
164/253
D208,431 S * 8/1967 Paulson D15/135
3,547,184 A * 12/1970 Navarro B22D 17/10
164/312
3,799,240 A * 3/1974 Baumann B22D 13/023
164/298
3,866,666 A * 2/1975 Wunder B22D 17/00
164/327
3,971,432 A * 7/1976 Hardey B22D 17/04
164/318
4,088,175 A * 5/1978 Cecere B22D 27/15
164/114

FIG. 1 is a front view of a casting machine of the present invention, including a main body portion, a lower mold portion, and an upper mold portion.
FIG. 2 is a rear view of the casting machine of FIG. 1.
FIG. 3 is a top plan view of the casting machine of FIG. 1.
FIG. 4 is a bottom plan view of the casting machine of FIG. 1.
FIG. 5 is a right side view of the casting machine of FIG. 1.
FIG. 6 is a left side view of the casting machine of FIG. 1.
FIG. 7 is a perspective view of the casting machine of FIG. 1.
FIG. 8 is a view of the casting machine of FIG. 1 showing the lower mold portion moved forward.
FIG. 9 is a view of the casting machine of FIG. 1 showing the upper and lower mold portions in a closed state.
FIG. 10 is a view of the casting machine of FIG. 1 showing the mold portions in a tilted state; and,
FIG. 11 is a view of the casting machine of FIG. 1 showing the upper mold portion moved forward.

(Continued)

1 Claim, 11 Drawing Sheets

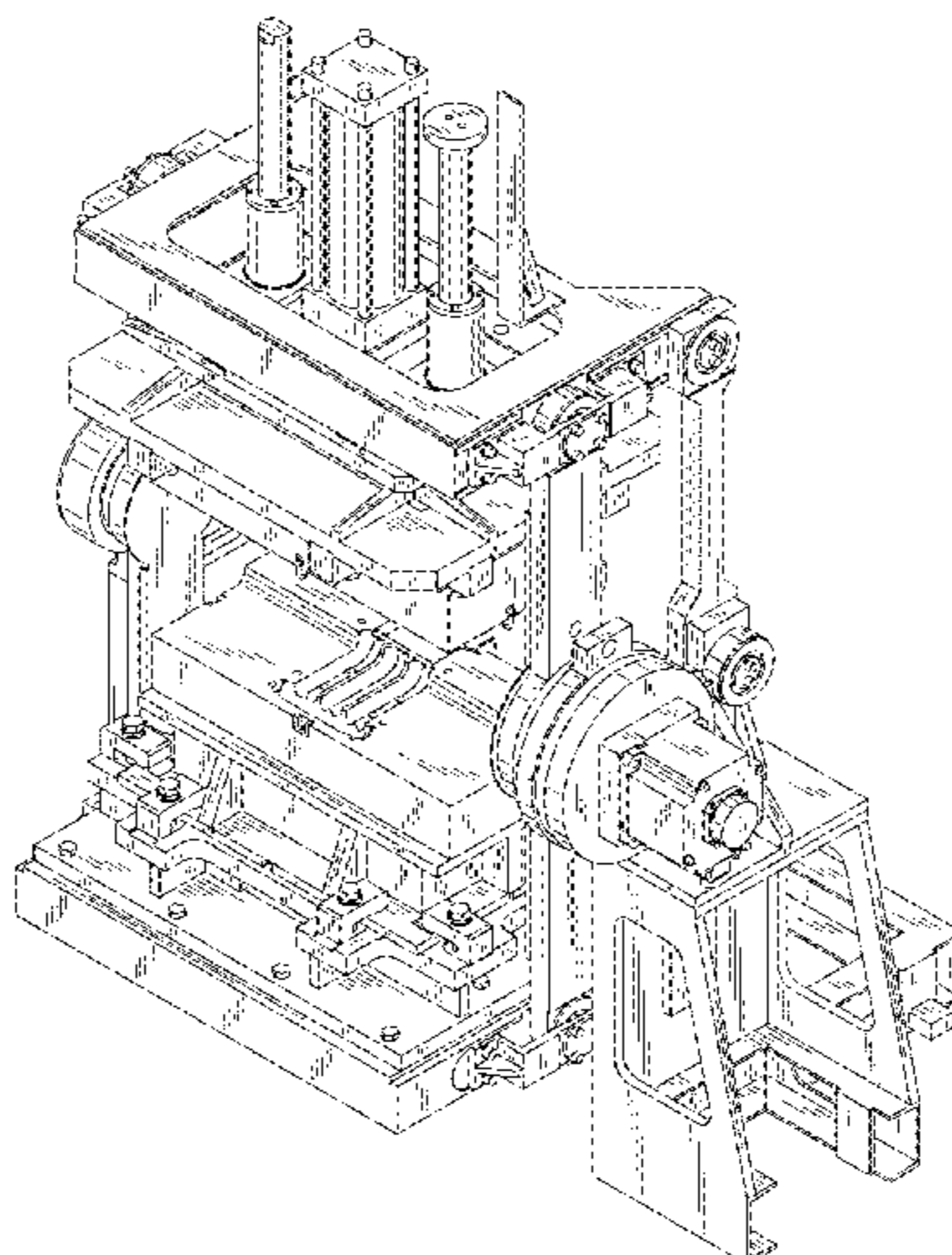

(56)

References Cited

U.S. PATENT DOCUMENTS

4,154,286 A * 5/1979 Glazunov B22D 17/10
164/133
4,240,497 A * 12/1980 Glazunov B22D 17/10
164/158
4,345,893 A * 8/1982 Prince B22D 17/10
425/190
D266,327 S * 9/1982 Haight D15/135
4,385,877 A * 5/1983 Tanabe B29C 45/0013
425/3
4,417,616 A * 11/1983 Seitz B22D 17/26
164/113
4,595,044 A * 6/1986 Caugherty B22D 17/2015
164/312
4,706,484 A * 11/1987 Dittmar B21B 13/10
72/225
4,719,676 A * 1/1988 Sansone B23B 3/30
29/26 A
D296,701 S * 7/1988 Lindell D15/135
D330,899 S * 11/1992 Holbl D15/135
D331,248 S * 11/1992 Yeh D15/135
5,207,264 A * 5/1993 You B22D 17/12
164/312
D336,479 S * 6/1993 Shuji Shinagawa D15/135
5,379,827 A * 1/1995 Perrella B22D 17/2015
164/316
D357,484 S * 4/1995 Montague D15/135
5,595,236 A * 1/1997 Lee B22D 17/10
164/319
5,964,274 A * 10/1999 Brinkley B29C 45/2673
164/312

D472,908 S * 4/2003 Schaer D15/147
6,772,819 B2 * 8/2004 Shiose B22D 18/04
164/119
6,942,010 B2 * 9/2005 Osugi B22D 23/006
164/336
6,978,823 B2 * 12/2005 Thibault B22D 17/2015
164/316
D547,336 S * 7/2007 Kai D15/122
D553,653 S * 10/2007 Kai D15/122
D617,356 S * 6/2010 Wang D15/135
7,806,161 B2 * 10/2010 Jezwinski B22C 11/10
164/130
D651,623 S * 1/2012 Stillwell D15/135
8,225,842 B2 * 7/2012 Taniguchi B22D 17/10
164/303
8,261,809 B2 * 9/2012 Shiose B22D 18/04
164/119
D690,331 S * 9/2013 Kitamura D15/122
D733,201 S * 6/2015 Baak D15/147
9,156,085 B2 * 10/2015 Zammattio B22D 17/10
9,289,821 B2 * 3/2016 Lee B22D 11/0622
9,370,822 B2 * 6/2016 Boni B22D 18/08
2008/0303183 A1 * 12/2008 Rote B29C 43/08
264/219

FOREIGN PATENT DOCUMENTS

JP 2007-054850 A 3/2007
JP 2010-005649 A 1/2010
TW 442222 6/2001
TW 200531764 A 10/2005
TW 159161 3/2014

* cited by examiner

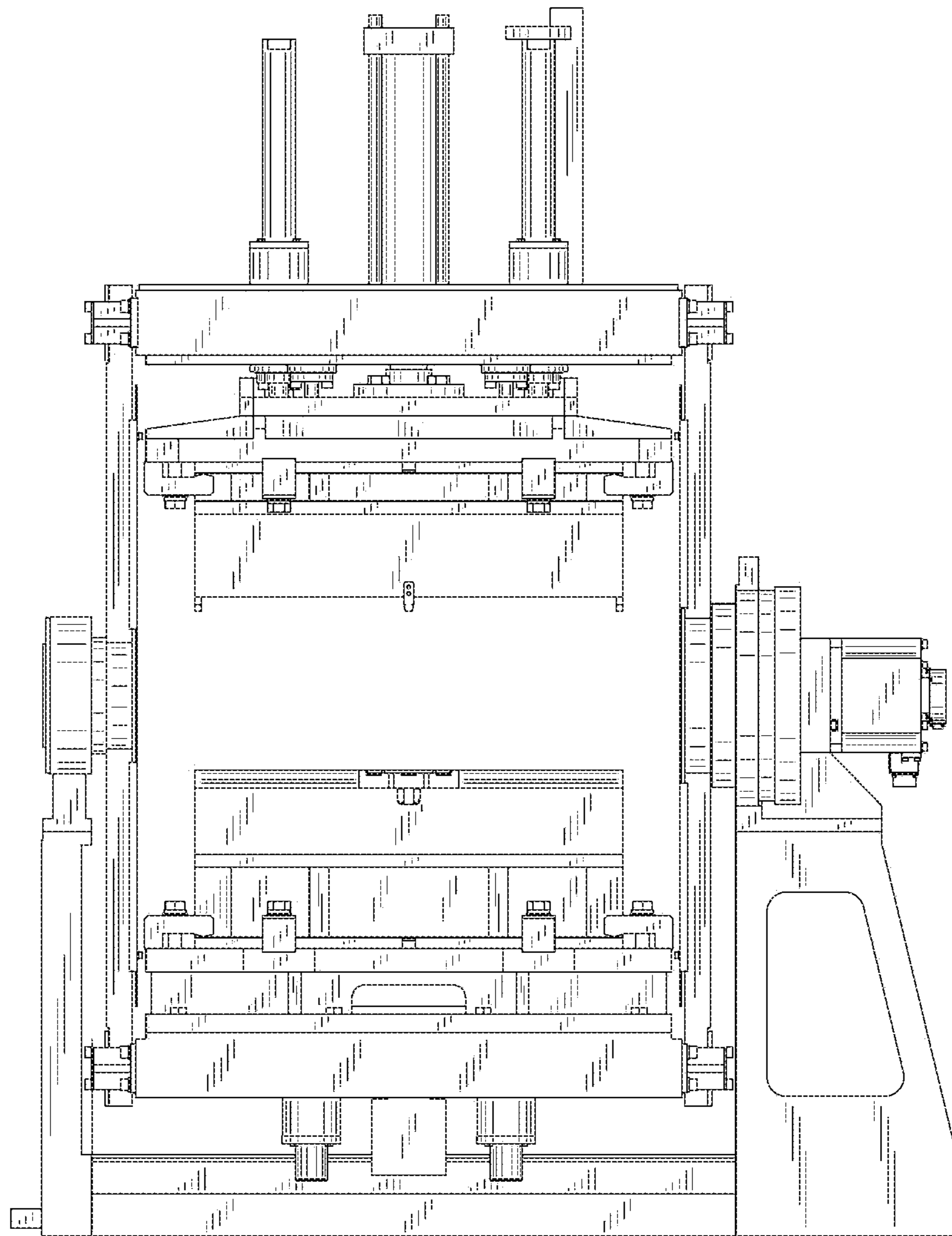

FIG. 1

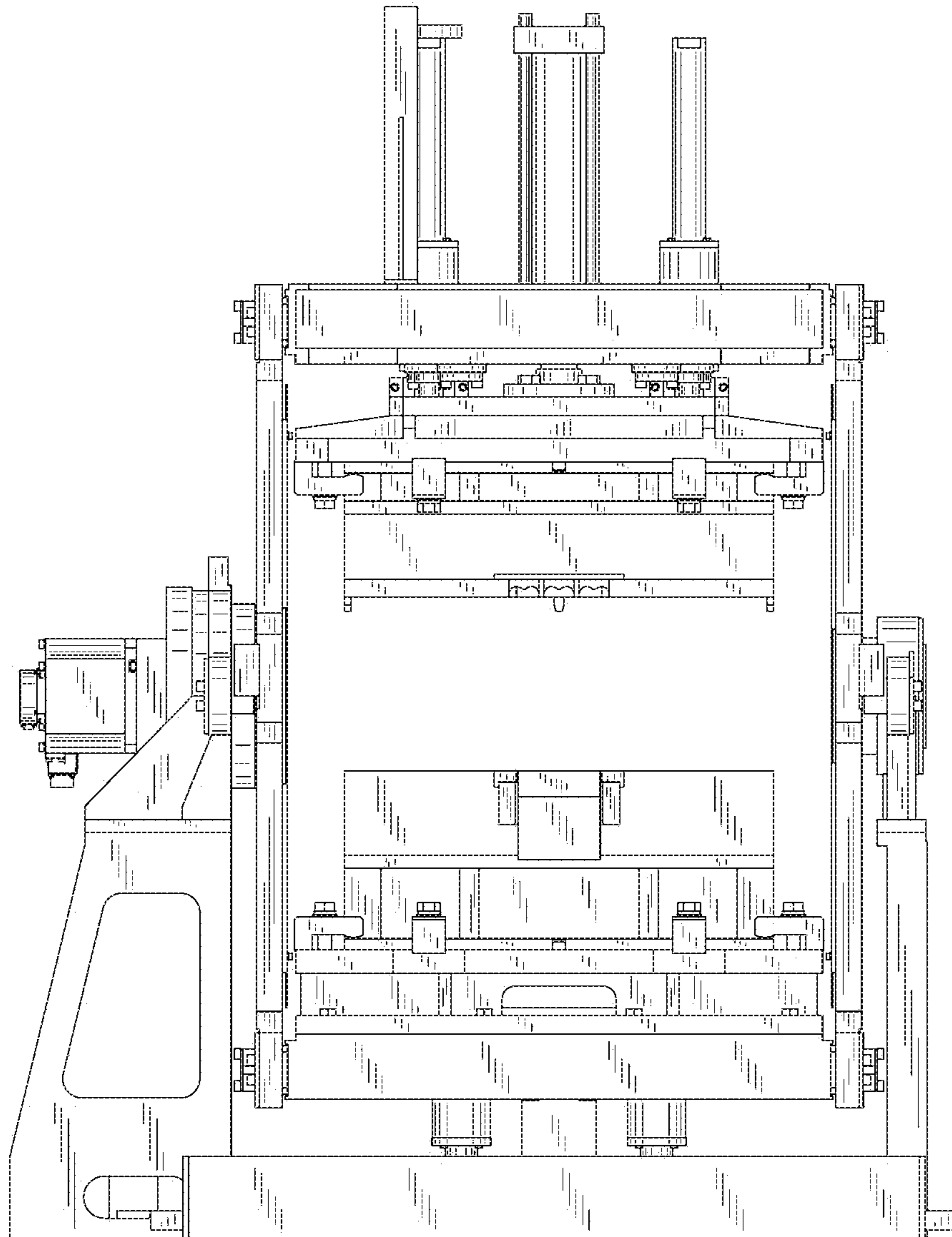

FIG. 2

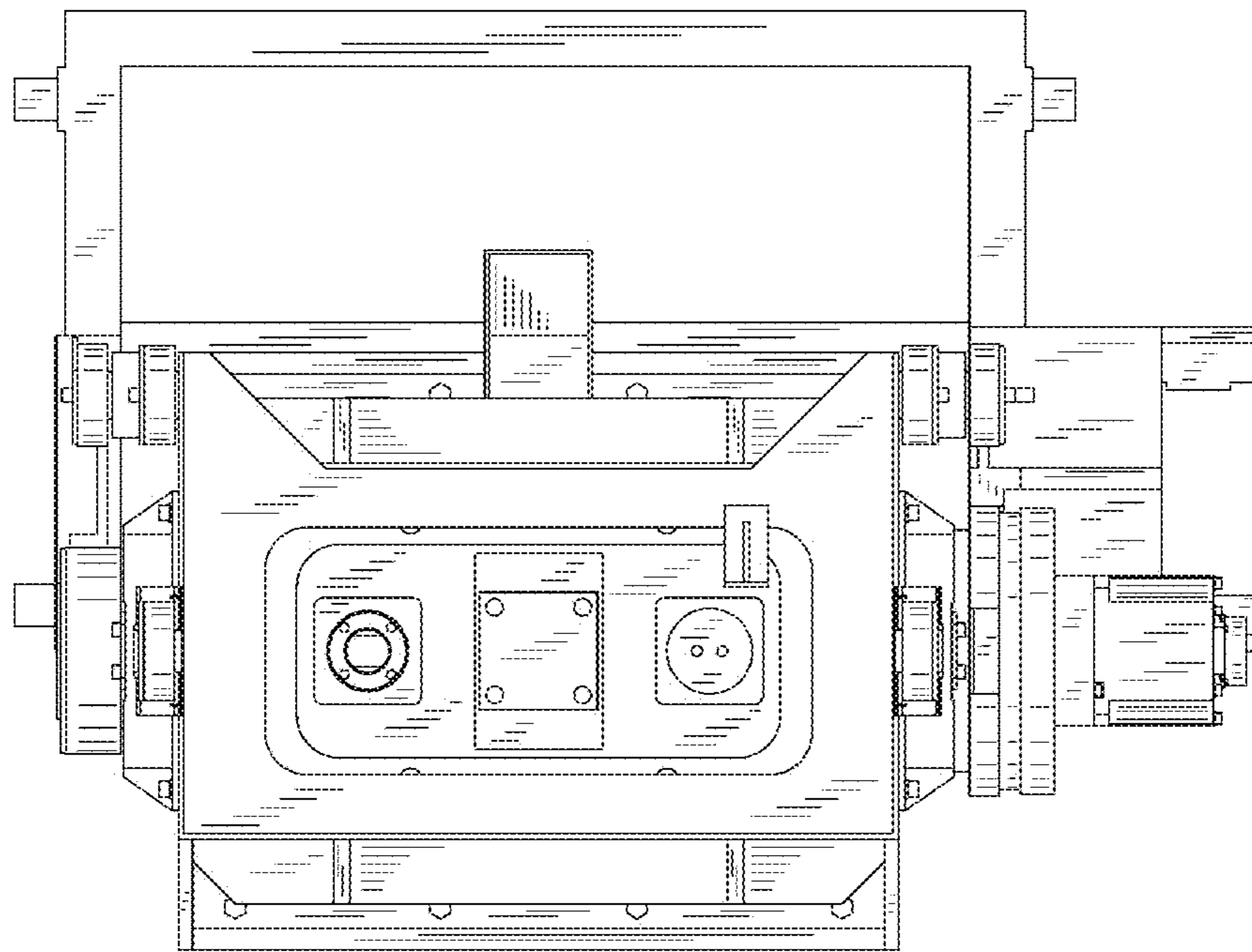

FIG. 3

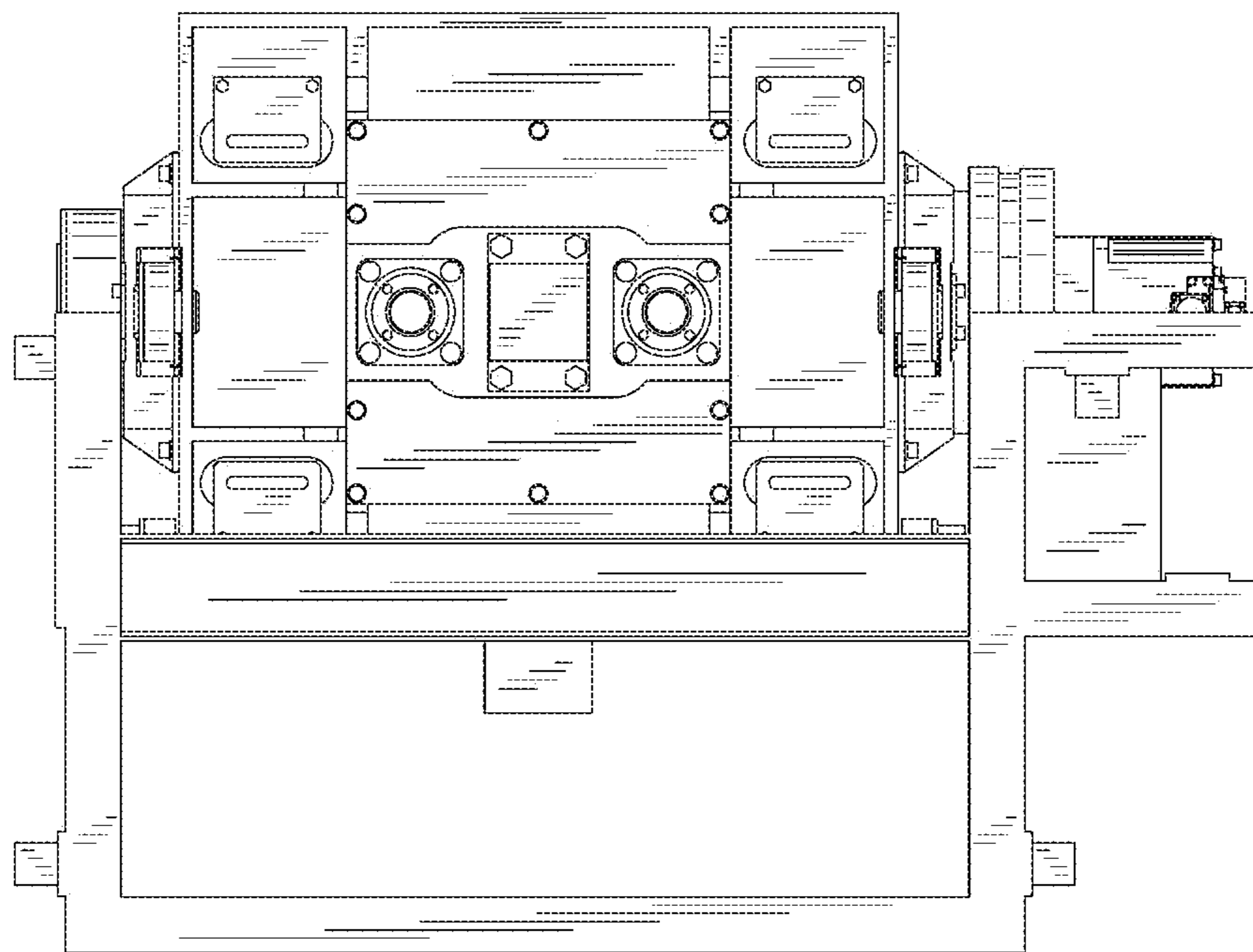

FIG. 4

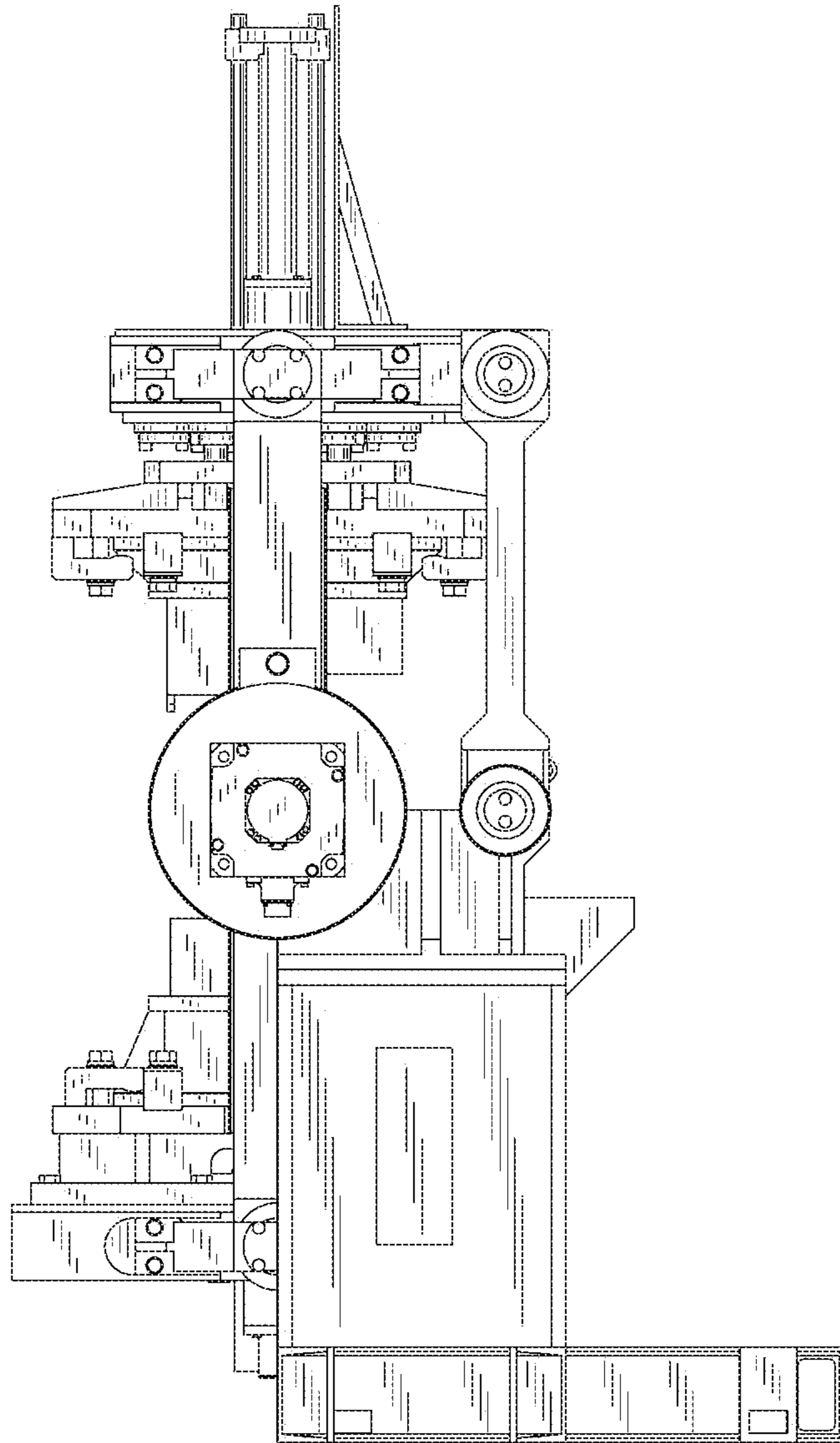

FIG. 5

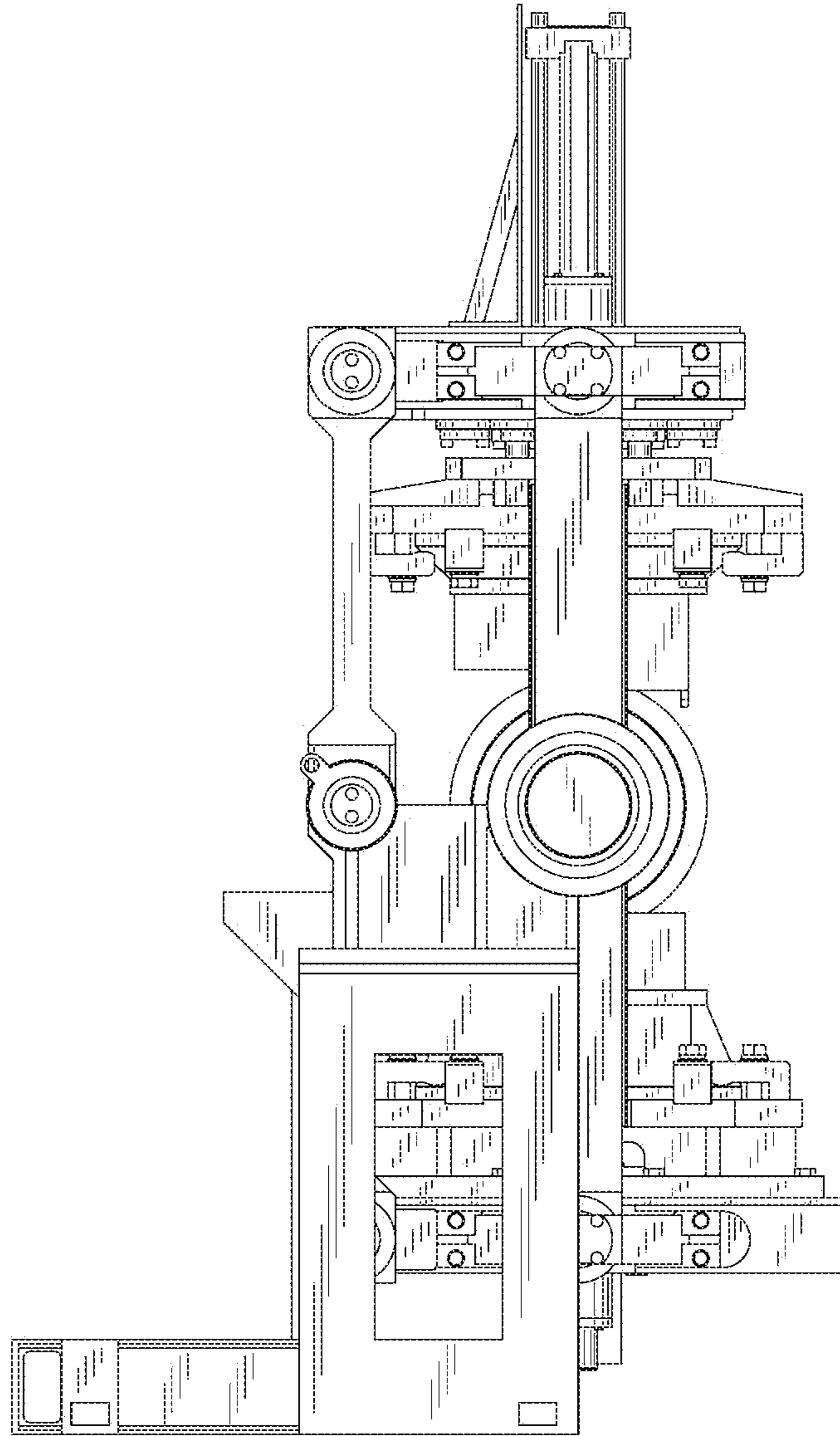

FIG. 6

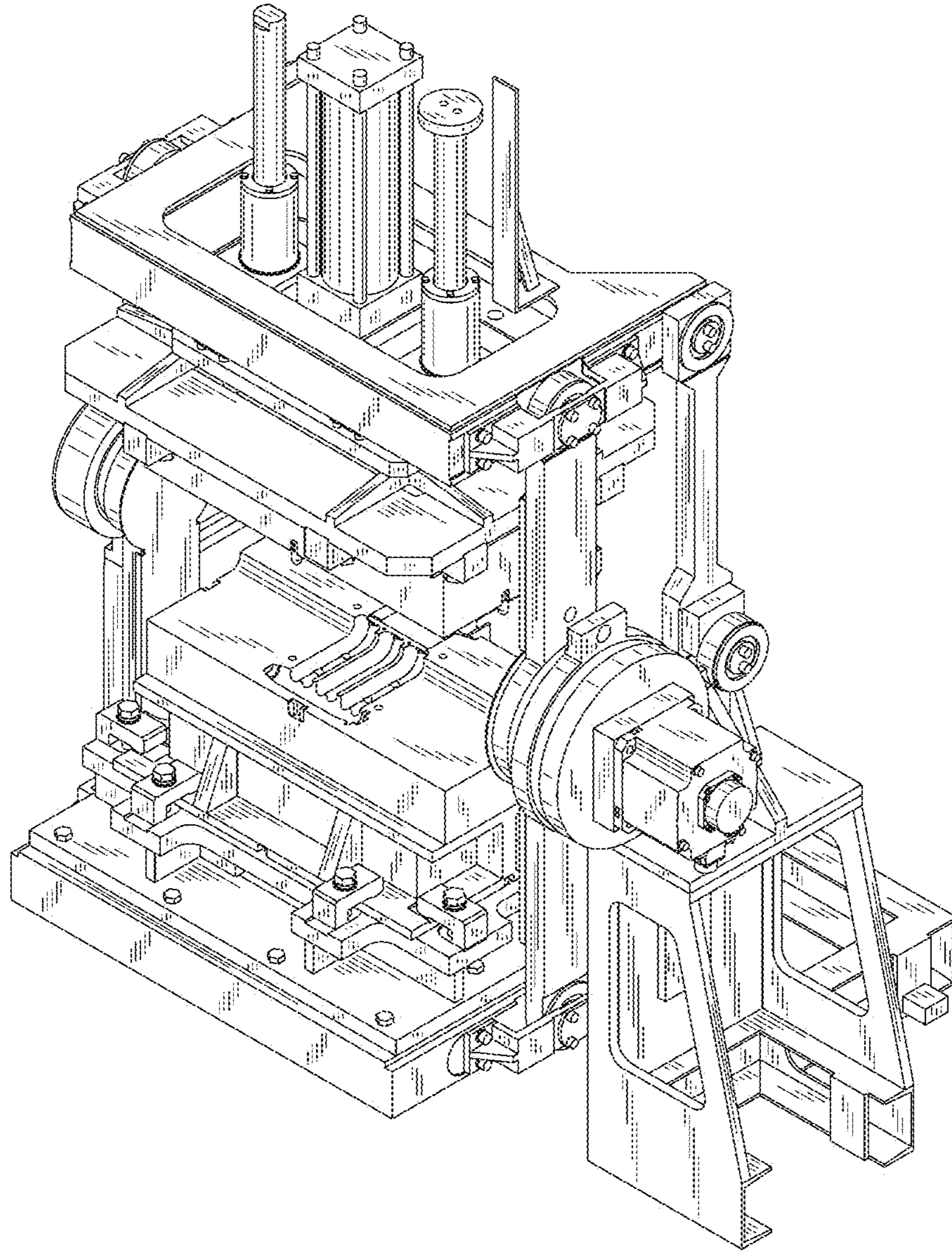

FIG. 7

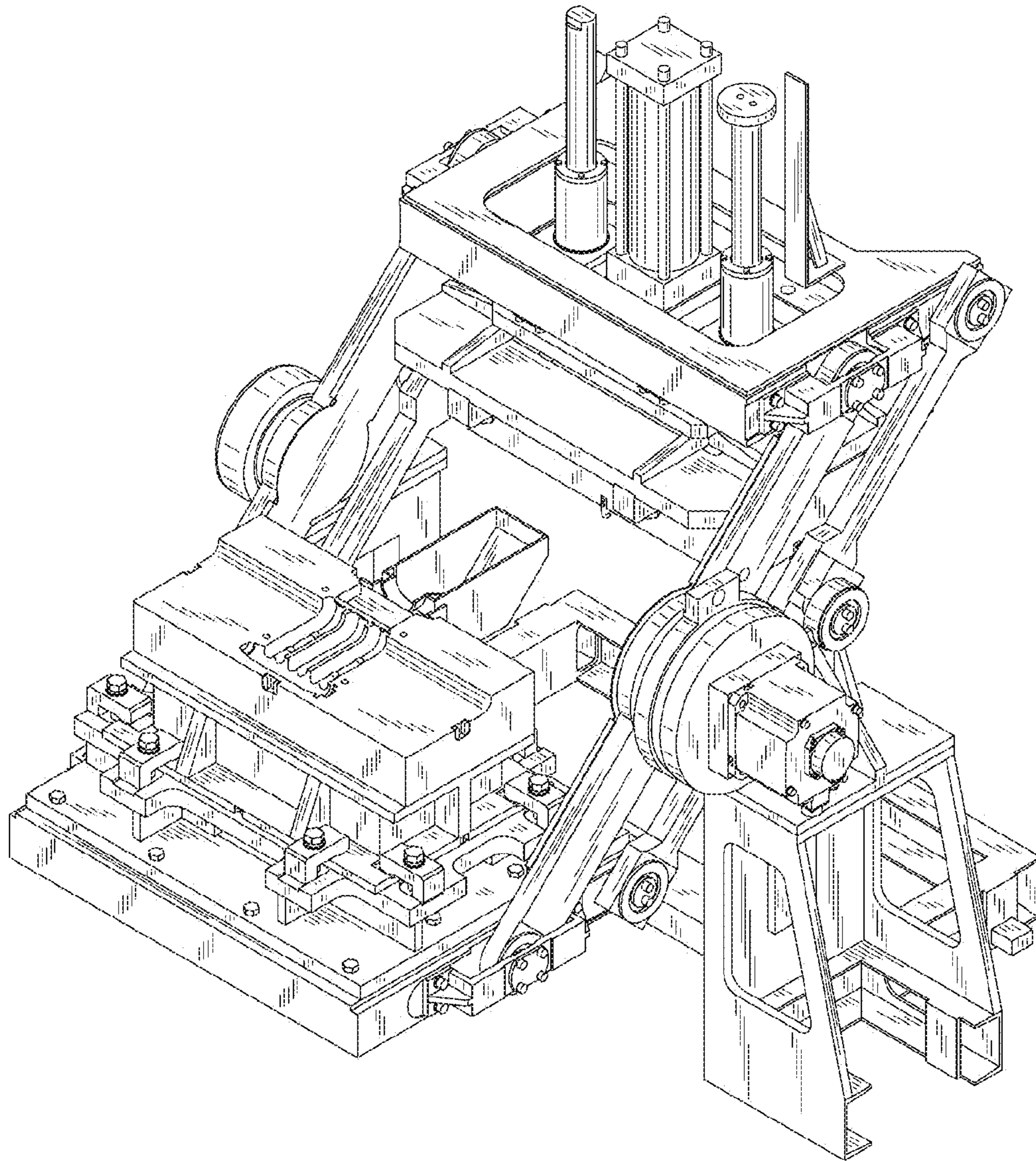

FIG. 8

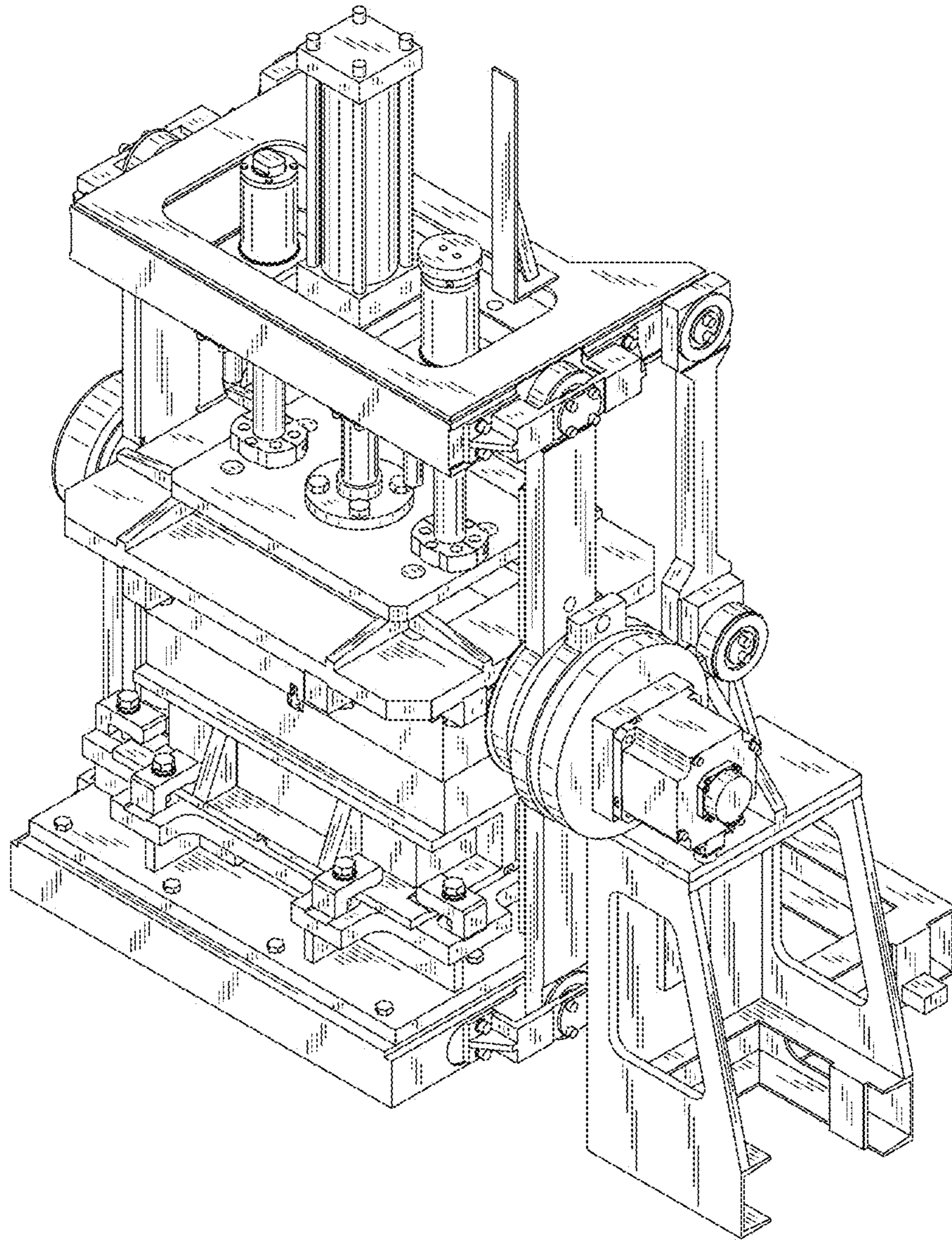

FIG. 9

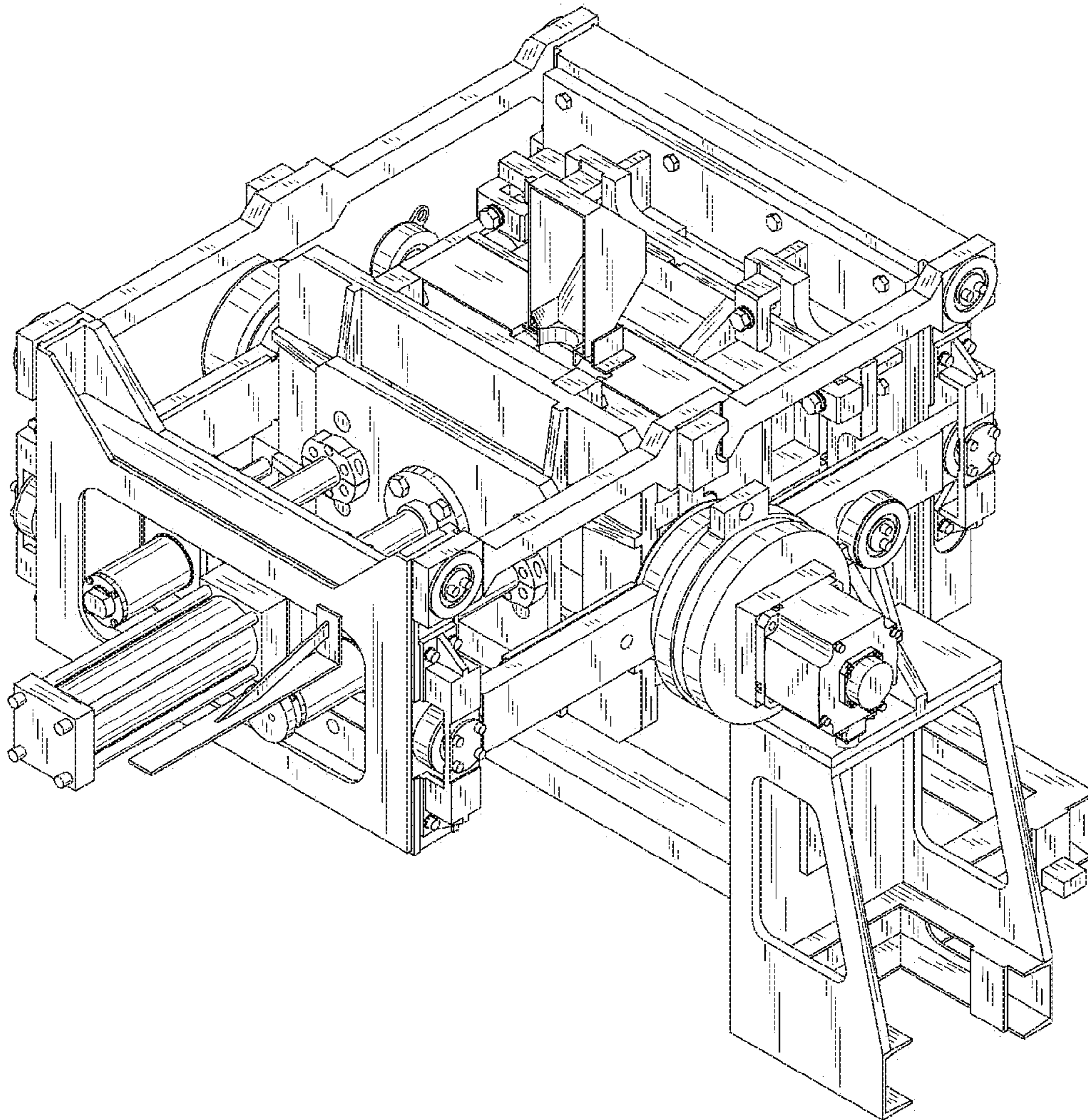

FIG. 10

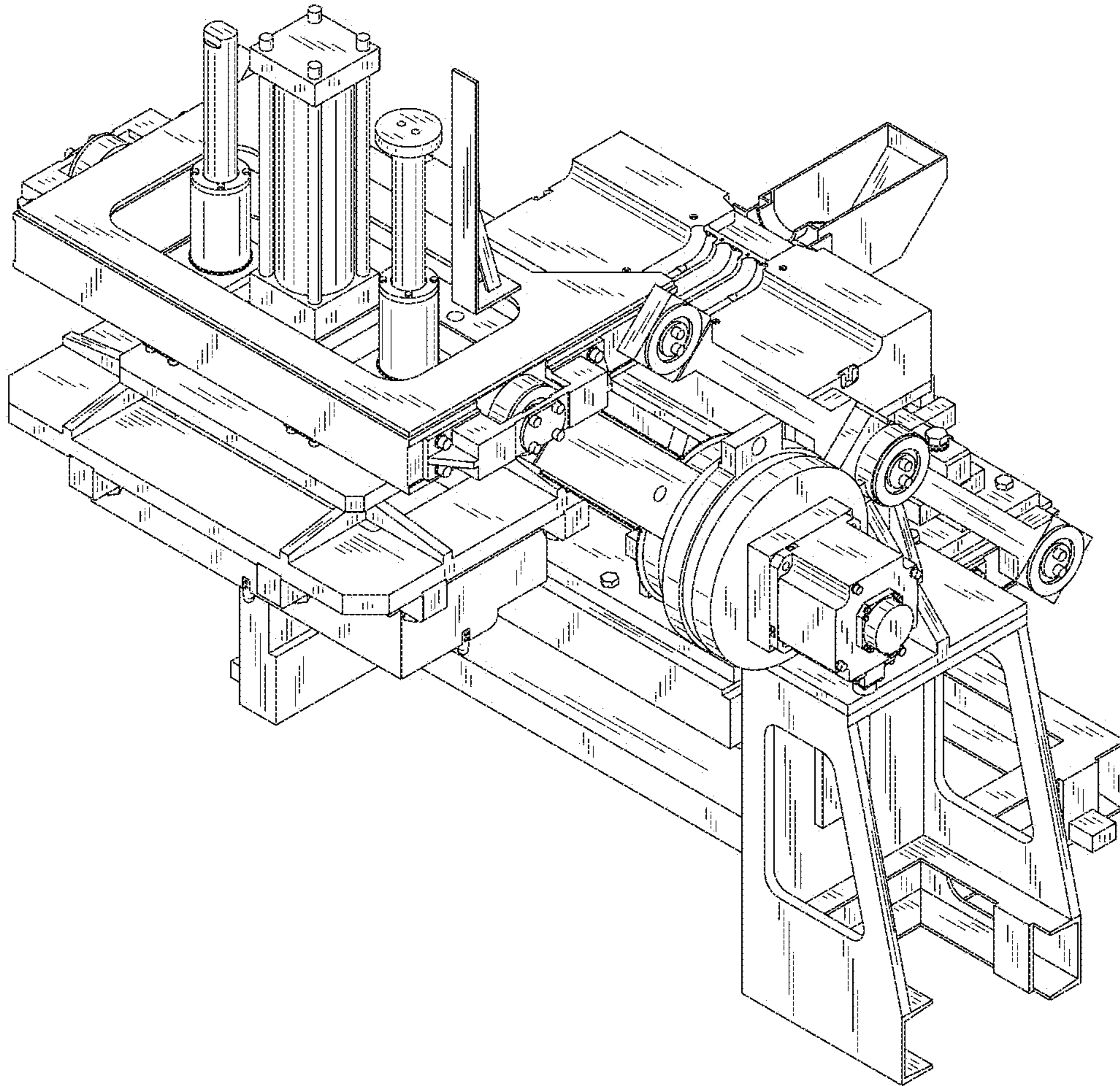

FIG. 11