

US00D768063S

(12) **United States Design Patent**  
**Sato**

(10) **Patent No.:** **US D768,063 S**  
(45) **Date of Patent:** **\*\* Oct. 4, 2016**

(54) **AUTOMOBILE TIRE**

(71) Applicant: **TOYO TIRE & RUBBER CO., LTD.**,  
Osaka-shi, Osaka (JP)

(72) Inventor: **Yoshiki Sato**, Osaka (JP)

(73) Assignee: **TOYO TIRE & RUBBER CO., LTD.**,  
Osaka-shi (JP)

(\*\*) Term: **15 Years**

(21) Appl. No.: **29/527,326**

(22) Filed: **May 18, 2015**

(30) **Foreign Application Priority Data**

Feb. 20, 2015 (JP) ..... 2015-003529

(51) **LOC (10) Cl.** ..... **12-15**

(52) **U.S. Cl.**  
USPC ..... **D12/601**

(58) **Field of Classification Search**  
USPC ..... D12/568-604, 900  
CPC ..... B60C 1/0016; B60C 11/0306; B60C  
11/0302; B60C 3/06; B60C 9/17  
See application file for complete search history.

(56) **References Cited**

**U.S. PATENT DOCUMENTS**

D377,330 S *	1/1997	Kakegawa	.....	D12/601
D415,982 S *	11/1999	Consolacion	.....	D12/601
D416,833 S	11/1999	Weber et al.	.....	
D593,937 S *	6/2009	Maxwell	.....	D12/588
D605,580 S *	12/2009	Williams	.....	D12/589
D648,265 S *	11/2011	Kim	.....	D12/588

D667,780 S *	9/2012	Kaba	.....	D12/588
D693,290 S *	11/2013	Yonetsu	.....	D12/586
D713,330 S *	9/2014	Tomida	.....	D12/588
D735,643 S *	8/2015	Fu	.....	D12/584

**FOREIGN PATENT DOCUMENTS**

JP 1419730 S 7/2012

\* cited by examiner

*Primary Examiner* — Robert M Spear

*Assistant Examiner* — John Voytek

(74) *Attorney, Agent, or Firm* — Westerman, Hattori,  
Daniels & Adrian, LLP

(57) **CLAIM**

The ornamental design for an automobile tire, as shown and described.

**DESCRIPTION**

FIG. 1 is a front view of an automobile tire, for which the rear view is the same;  
 FIG. 2 is a top plan view thereof, for which the bottom plan view is the same;  
 FIG. 3 is a right side view thereof, for which the left-side view is the same;  
 FIG. 4 is a perspective view thereof;  
 FIG. 5 is an enlarged sectional view taken along line 5-5 and line 5'-5' in FIG. 1; and,  
 FIG. 6 is an enlarged cross-sectional view taken along line 6-6 in FIG. 1, in the area designated by "6" in FIG. 3 thereof.  
 In the drawings, the broken lines defining the sidewall, inner bead and the peripheral boundary between the claimed tire tread and the unclaimed sidewall depict environmental subject matter that forms no part of the claimed design.

**1 Claim, 6 Drawing Sheets**

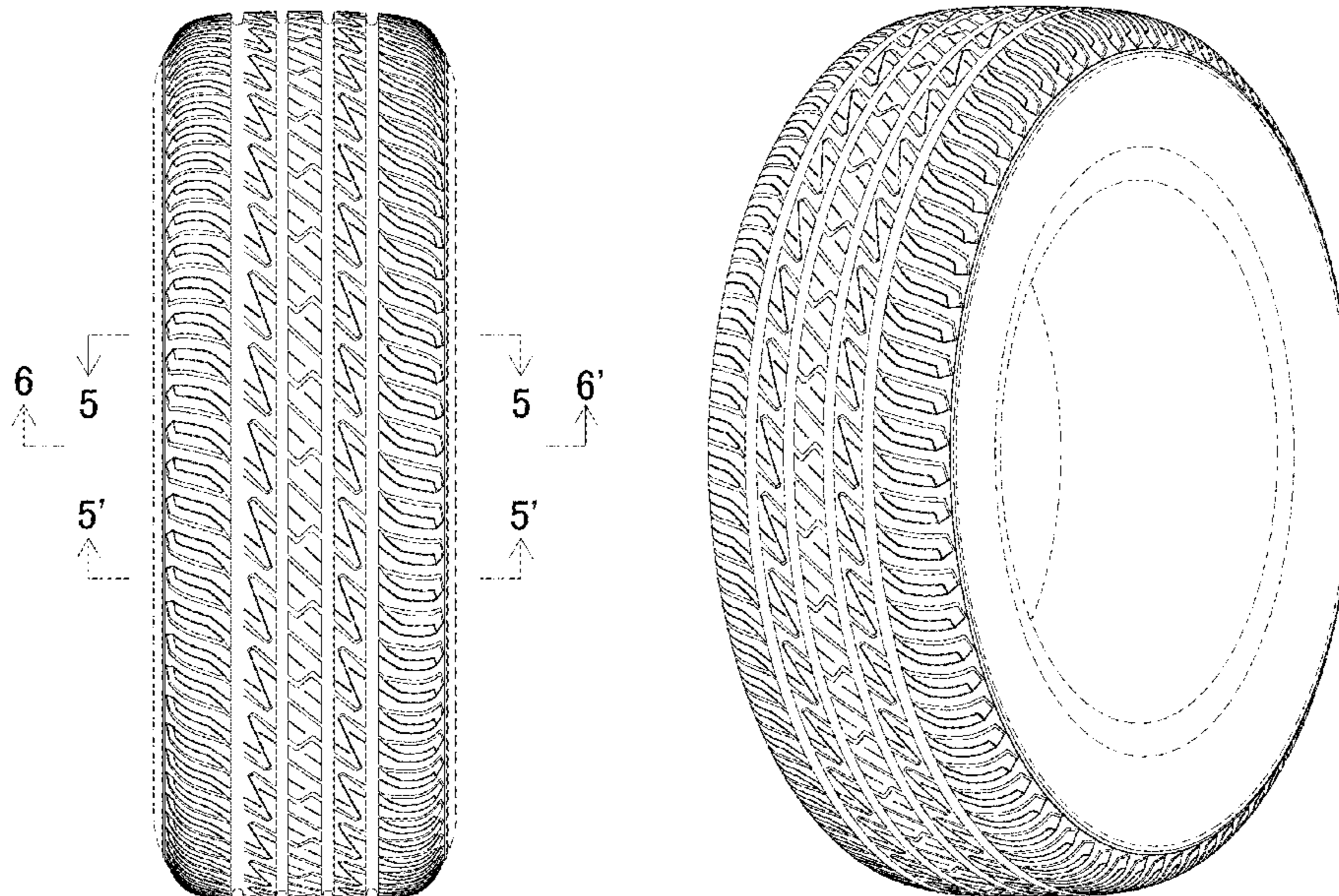

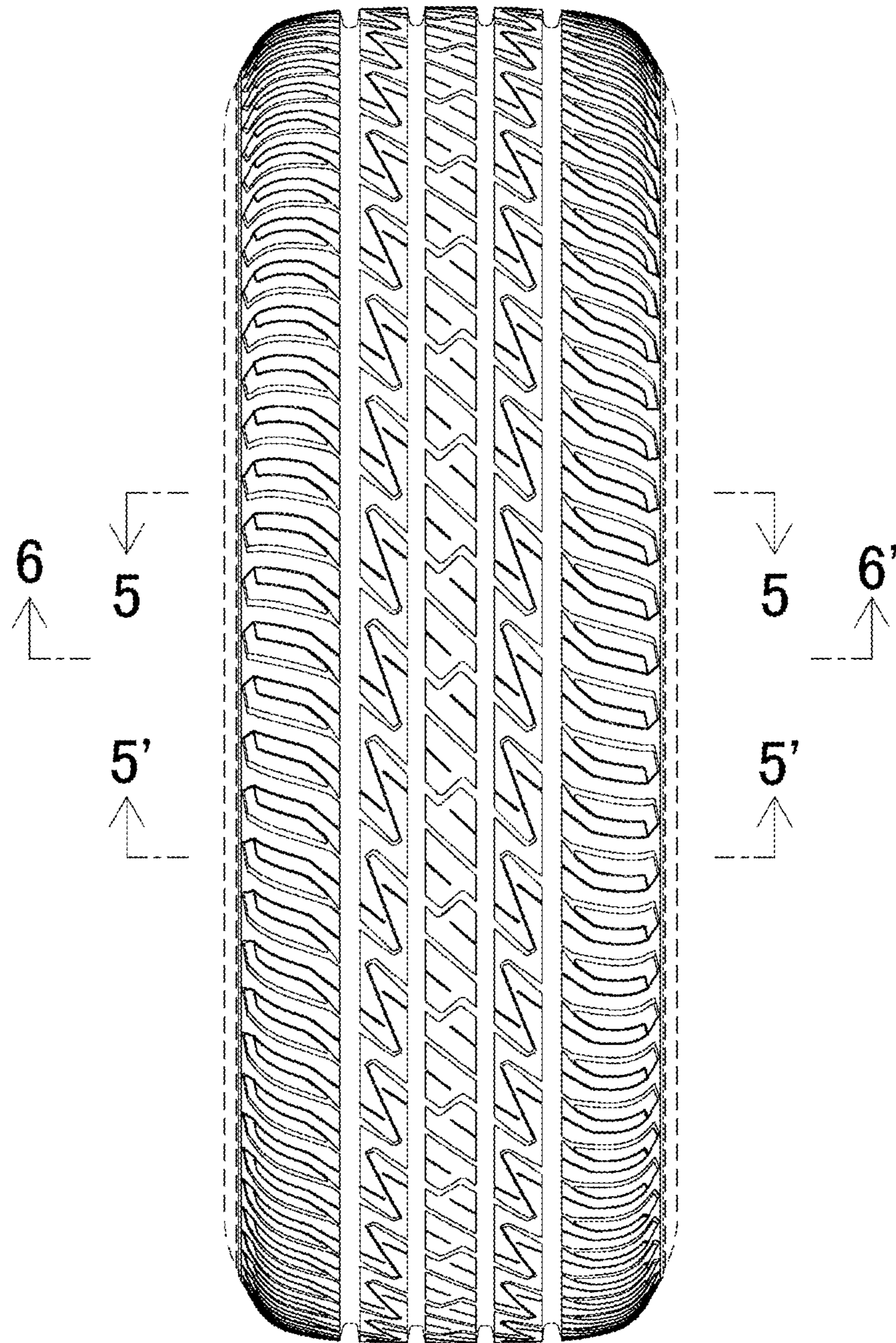

FIG.1

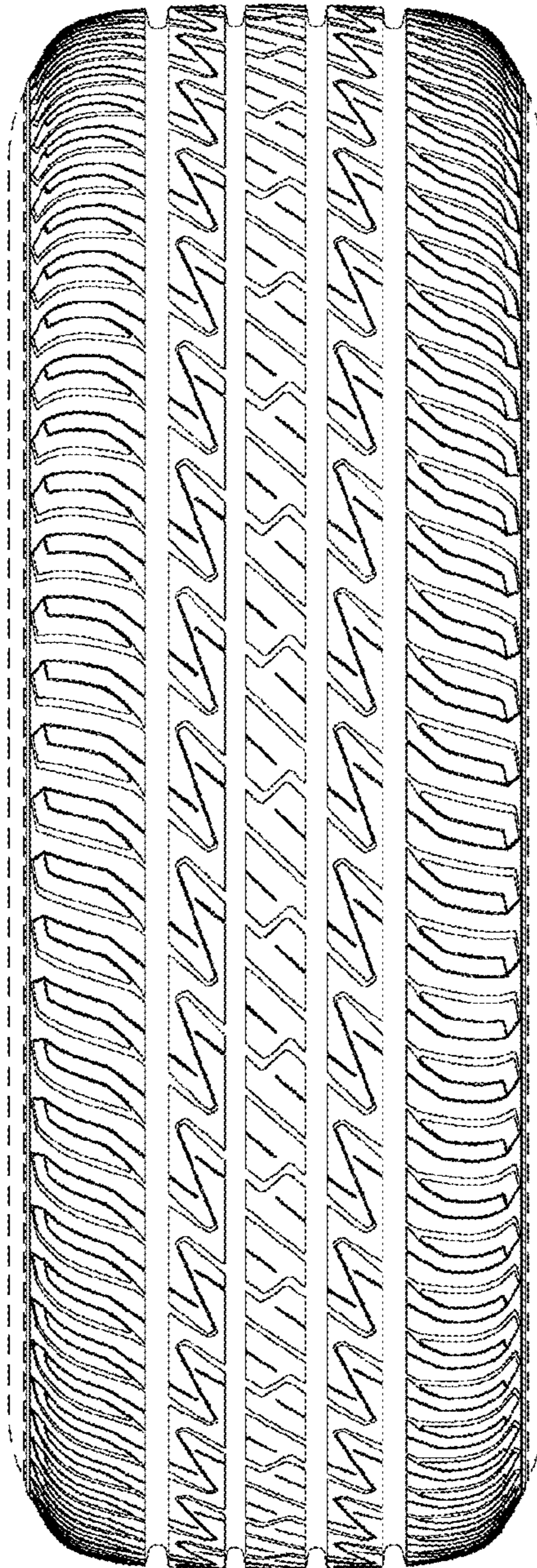
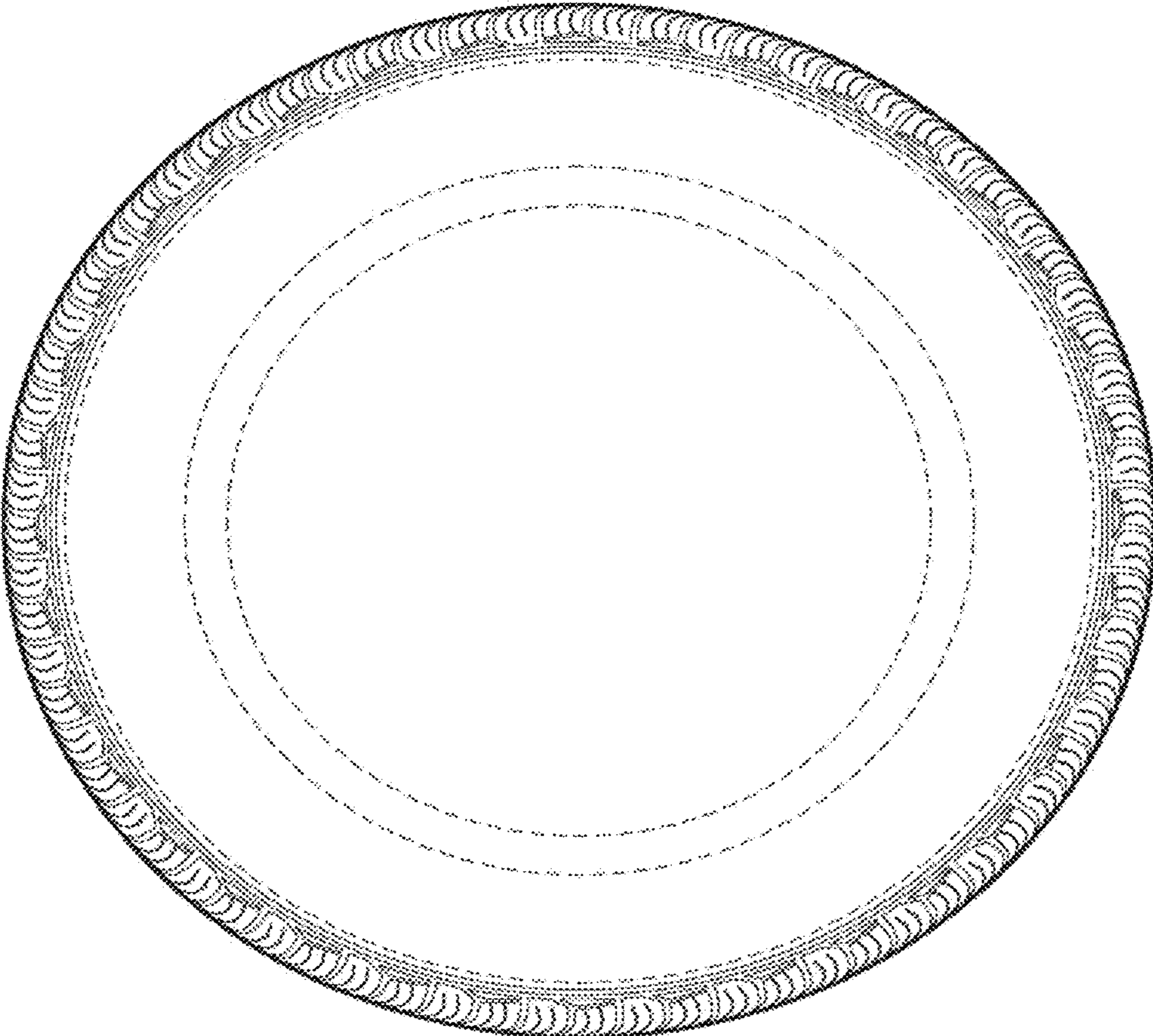

FIG.2

FIG.3



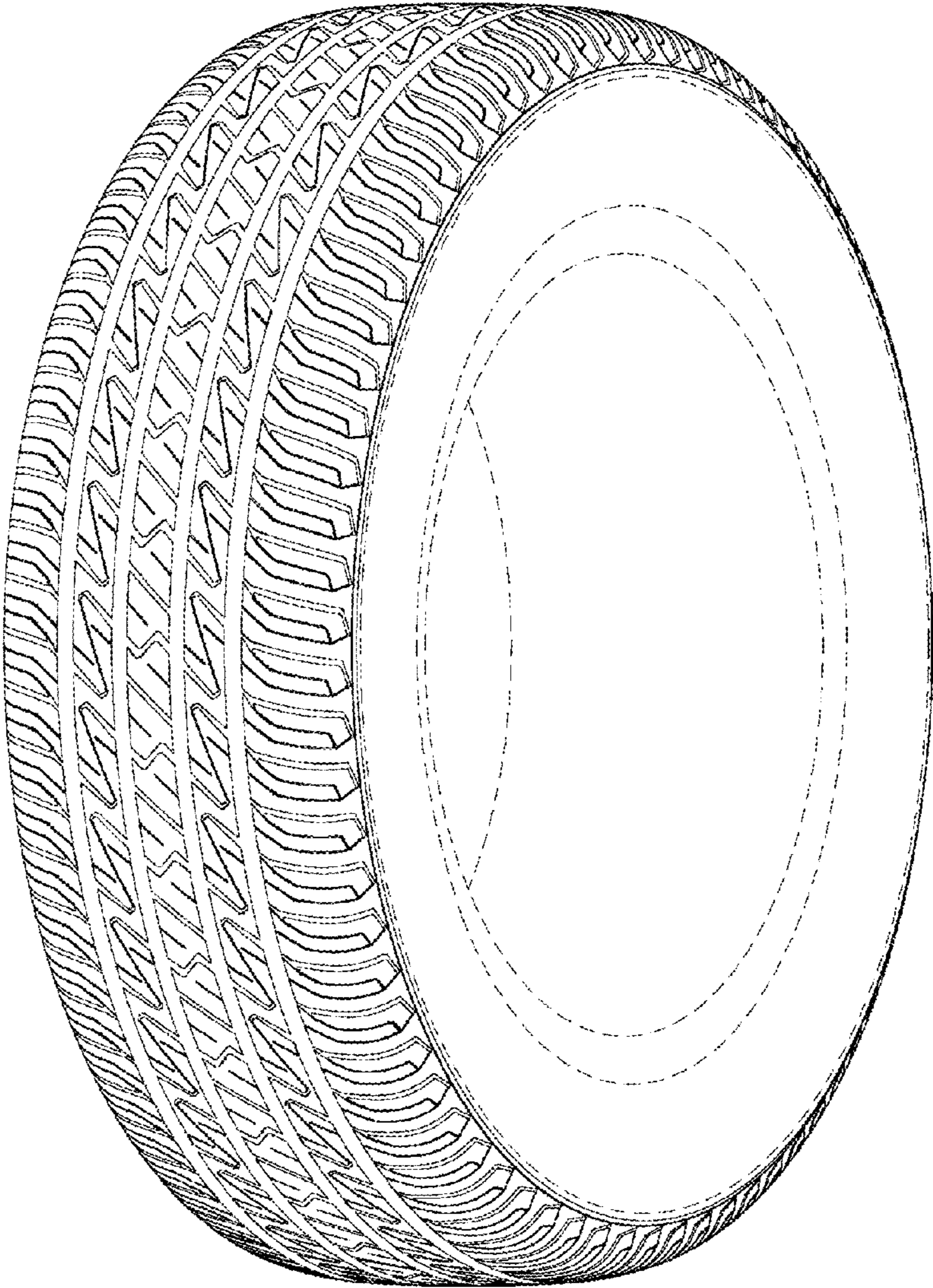

FIG.4

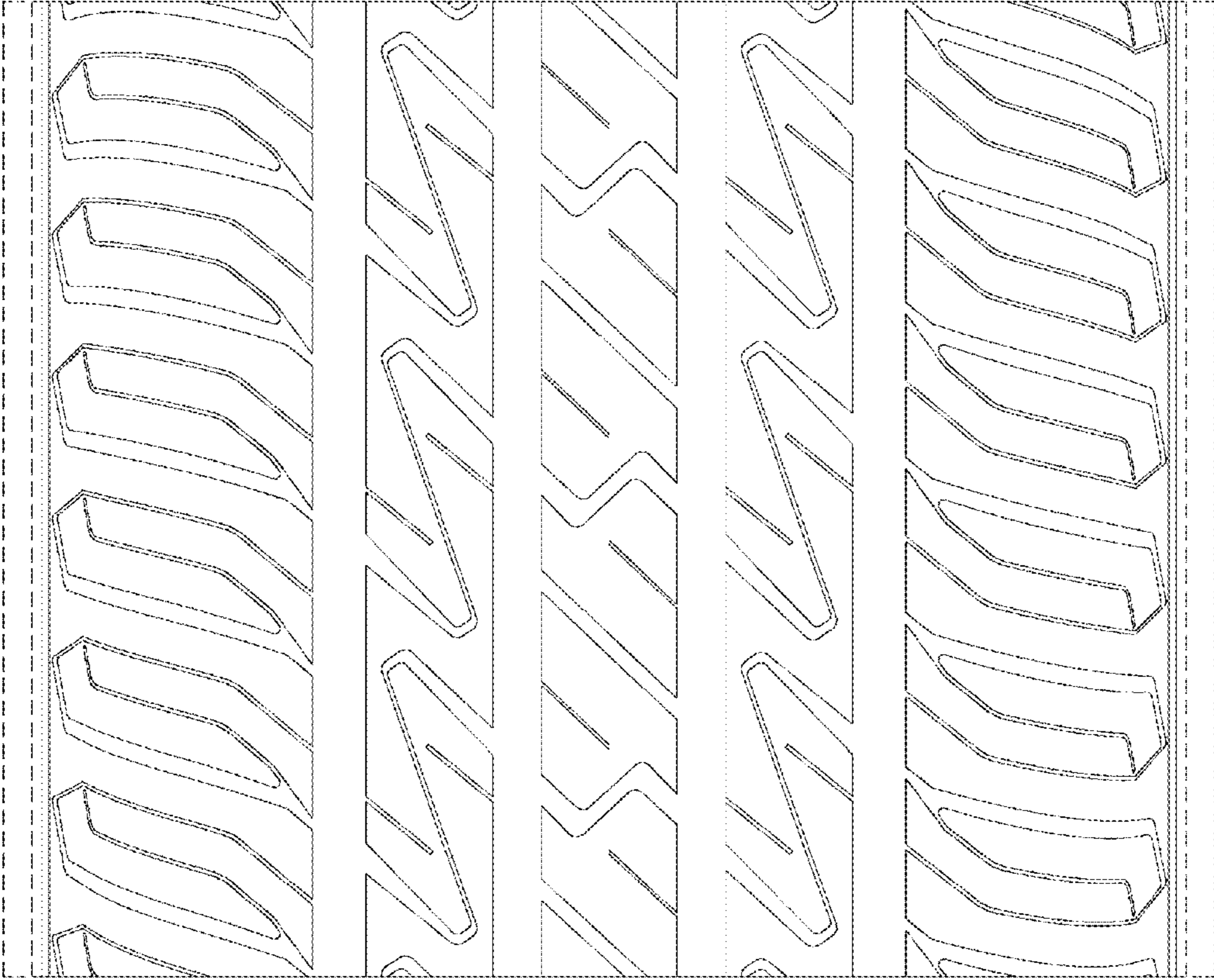

FIG.5

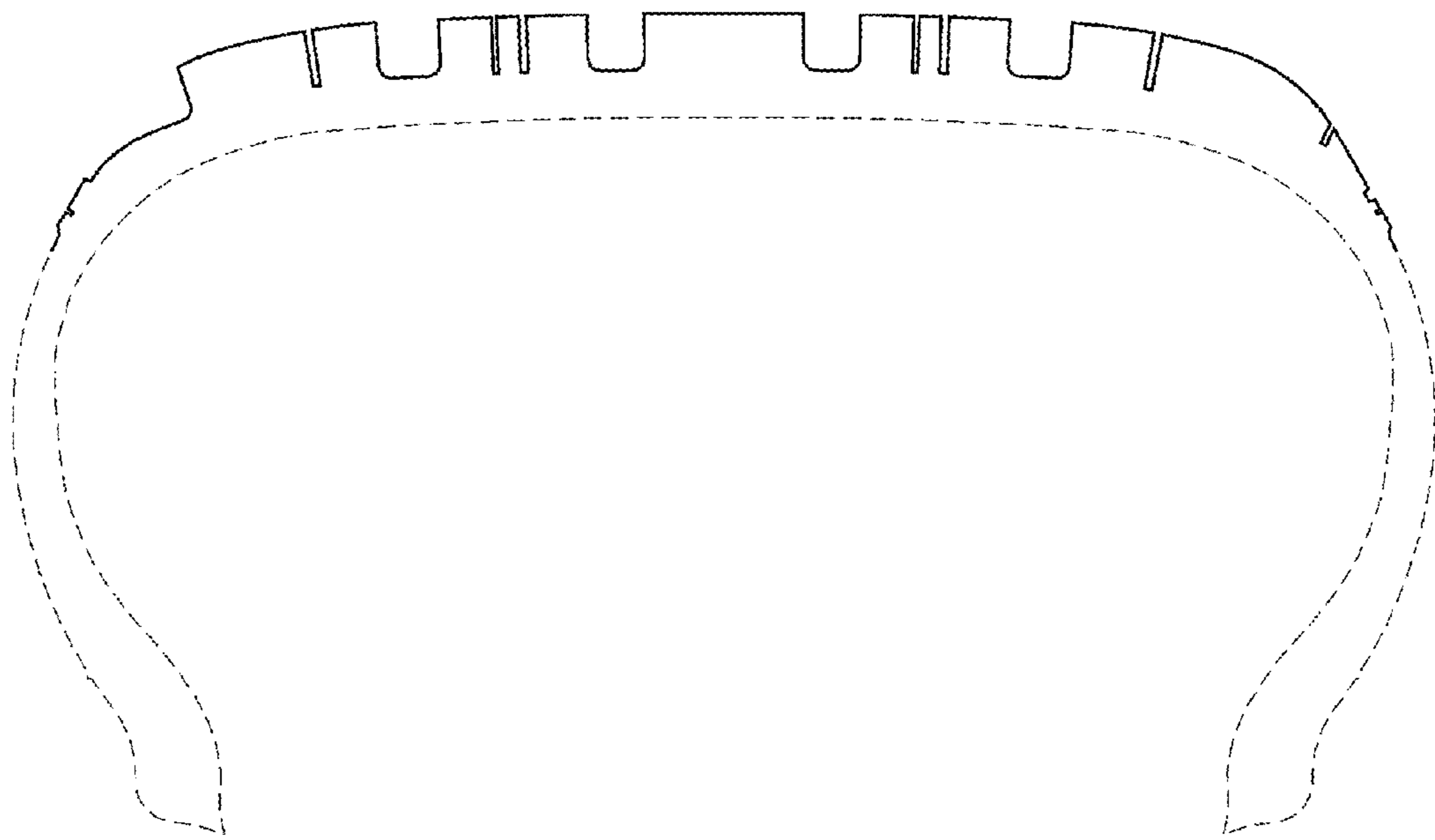

FIG.6