

US00D767910S

(12) **United States Design Patent**
Toll

(10) **Patent No.:** **US D767,910 S**

(45) **Date of Patent:** **** *Oct. 4, 2016**

- (54) **BICYCLE SEAT**
- (71) Applicant: **TAMPA BAY RECREATION, LLC**,
Lutz, FL (US)
- (72) Inventor: **Steven G. Toll**, Tampa, FL (US)
- (73) Assignee: **ISM Saddles, LLC**, Lutz, FL (US)
- (*) Notice: This patent is subject to a terminal disclaimer.
- (**) Term: **14 Years**

(21) Appl. No.: **29/499,700**

(22) Filed: **Aug. 18, 2014**
Related U.S. Application Data

(63) Continuation-in-part of application No. 29/498,584,
filed on Aug. 5, 2014.

(51) **LOC (10) Cl.** **12-11**

(52) **U.S. Cl.**
USPC **D6/354**

(58) **Field of Classification Search**
USPC D6/354, 340; D12/111, 112
CPC B62J 1/005; B62J 1/002; B62J 1/26;
B62J 1/00; B62J 1/007; B62J 1/02; B62J
1/04; B62J 1/06; B62J 1/08
See application file for complete search history.

(56) **References Cited**

U.S. PATENT DOCUMENTS

642,191 A 1/1890 Wright
464,653 A 12/1891 Latta

(Continued)

FOREIGN PATENT DOCUMENTS

JP 2007-186075 7/2007
JP 2008-509047 3/2008

(Continued)

OTHER PUBLICATIONS

U.S. Appl. No. 29/484,042, filed Jul. 29, 2014 with the following characterization: "Podium Imports ISM Saddles." Podium Imports., Feb. 20, 2013 [online], [retrieved on Jul. 19, 2014]. Retrieved from the Internet <URL: <http://www.podiumimports.ca/shop—online/brand/ism—saddles/>>.

(Continued)

Primary Examiner — George D Kirschbaum
Assistant Examiner — Jennifer Watkins
(74) *Attorney, Agent, or Firm* — Akerman LLP; Peter A. Chiabotti

(57) **CLAIM**
The ornamental design for a bicycle seat, as shown and described.

DESCRIPTION

FIG. 1 is a perspective view of the bicycle seat showing my new design;
FIG. 2 is a top plan view thereof;
FIG. 3 is a bottom plan view thereof;
FIG. 4 is a left side elevation view thereof;
FIG. 5 is a right side elevation view thereof;
FIG. 6 is a front view thereof;
FIG. 7 is a rear view thereof;
FIG. 8 is a perspective view of the bicycle seat showing my new design in accordance to an alternative embodiment;
FIG. 9 is a top plan view thereof;
FIG. 10 is a bottom plan view thereof;
FIG. 11 is a left side elevation view thereof;
FIG. 12 is a right side elevation view thereof;
FIG. 13 is a front view thereof;
FIG. 14 is a rear view thereof;
FIG. 15 is a perspective view of the bicycle seat showing my new design in accordance to an alternative embodiment;
FIG. 16 is a top plan view thereof;
FIG. 17 is a bottom plan view thereof;
FIG. 18 is a left side elevation view thereof;
FIG. 19 is a right side elevation view thereof;
FIG. 20 is a front view thereof;
FIG. 21 is a rear view thereof;
FIG. 22 is a perspective view of the bicycle seat showing my new design in accordance to an alternative embodiment;
FIG. 23 is a top plan view thereof;
FIG. 24 is a bottom plan view thereof;
FIG. 25 is a left side elevation view thereof;
FIG. 26 is a right side elevation view thereof;
FIG. 27 is a front view thereof; and,
FIG. 28 is a rear view thereof.
The portions shown in broken lines form no part of the claimed design.

1 Claim, 24 Drawing Sheets

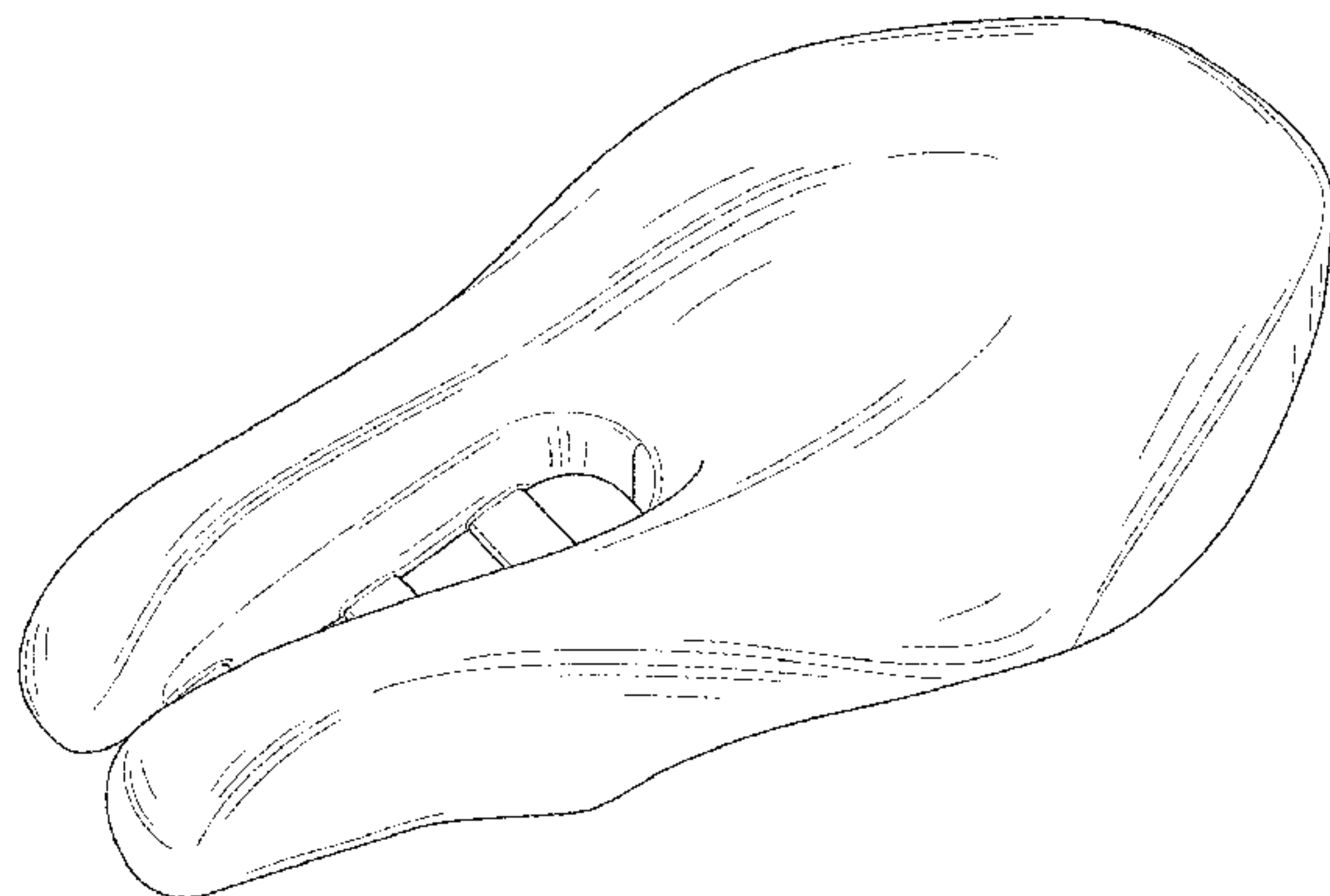
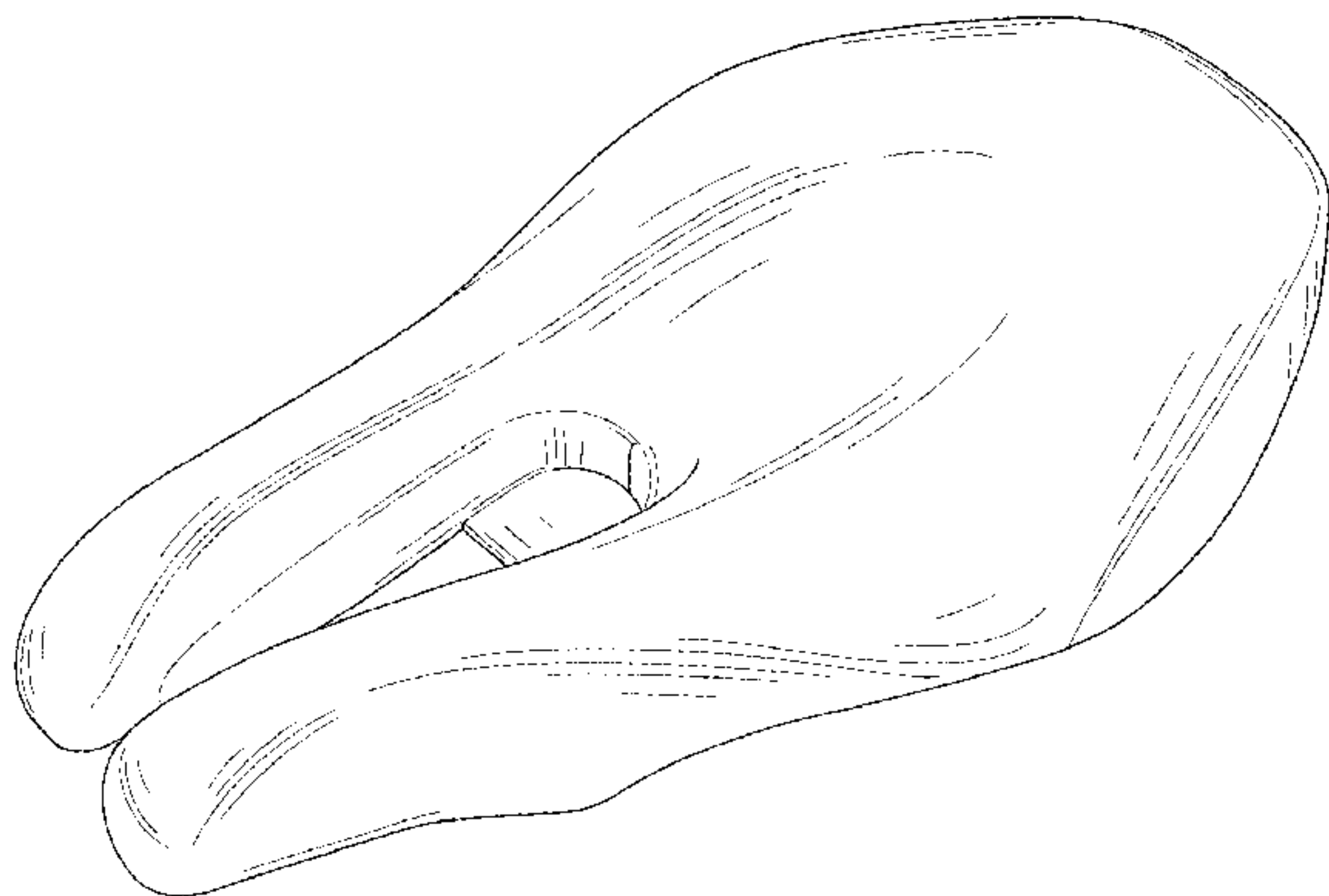

(56)

References Cited

U.S. PATENT DOCUMENTS

532,444 A 1/1895 Christy
 537,375 A 4/1895 Wright et al.
 568,626 A 9/1896 Pierce et al.
 570,497 A 11/1896 Pattison
 572,062 A 11/1896 Peck
 602,732 A 4/1898 Craig
 605,151 A 6/1898 Twist
 608,682 A 8/1898 Jamieson
 612,552 A 10/1898 Standeford
 612,972 A 10/1898 Leech
 D29,719 S 11/1898 Leech et al.
 619,204 A 2/1899 Moore
 622,357 A 4/1899 Hitchcock et al.
 623,238 A 4/1899 Davis
 629,956 A 8/1899 Craig
 635,598 A 10/1899 Rowe
 654,720 A 7/1900 Englebert
 701,390 A 6/1902 Provoost
 872,124 A 11/1907 Hammaren
 1,462,976 A 9/1922 Mesinger
 1,538,542 A 2/1924 Blake
 1,858,477 A 5/1932 Blake
 3,844,611 A 10/1974 Young
 4,429,915 A 2/1984 Flager
 4,898,422 A 2/1990 West
 4,999,068 A 3/1991 Chiarella
 5,011,222 A 4/1991 Yates et al.
 5,108,076 A 4/1992 Chiarella
 5,167,435 A 12/1992 Aldi
 5,676,420 A 10/1997 Kuipers et al.
 5,765,912 A 6/1998 Bontrager
 5,863,094 A 1/1999 Endo
 5,873,626 A 2/1999 Katz
 D407,910 S 4/1999 Terry
 D408,159 S 4/1999 Clutton
 D409,009 S 5/1999 Toll et al.
 D416,394 S 11/1999 Minkow et al.
 D417,560 S 12/1999 Tollefson et al.
 6,019,423 A 2/2000 Dodge et al.
 6,039,395 A 3/2000 Culbertson
 D429,905 S 8/2000 White
 6,113,184 A 9/2000 Barnes
 6,139,098 A 10/2000 Carrillo
 6,193,309 B1 2/2001 Gootter et al.
 6,224,151 B1 * 5/2001 McMullen, Jr. B62J 1/002
 297/195.1 D6/354
 D443,426 S * 6/2001 Diaz
 6,244,655 B1 6/2001 Minkow et al.
 6,290,291 B1 9/2001 Kojima
 D454,258 S 3/2002 Yates
 6,422,647 B1 7/2002 Turudich
 6,450,572 B1 9/2002 Kuipers
 6,652,025 B2 11/2003 Sylvester
 6,669,283 B2 12/2003 Yu
 6,761,400 B2 7/2004 Hobson
 6,783,176 B2 8/2004 Ladson, III
 6,880,885 B2 4/2005 Lan
 6,957,857 B1 10/2005 Lee
 7,025,417 B2 4/2006 Cohen
 7,077,469 B2 7/2006 Farré
 7,104,600 B2 9/2006 Scholz
 7,121,622 B1 10/2006 Mendez
 7,374,517 B2 5/2008 Lockett
 D575,070 S 8/2008 Toll
 7,441,836 B2 10/2008 Chen et al.
 7,478,871 B2 1/2009 Pandozy
 7,537,281 B2 5/2009 Riondato
 D604,056 S 11/2009 Toll et al.
 D604,057 S 11/2009 Toll
 7,699,391 B2 4/2010 Riondato
 D622,973 S 9/2010 Toll
 7,934,770 B2 5/2011 Toll
 D639,081 S 6/2011 Toll
 7,976,102 B2 7/2011 Chang
 D642,846 S 8/2011 Parish et al.

D677,479 S 3/2013 Toll
 D684,780 S 6/2013 Toll
 D684,781 S 6/2013 Toll
 8,480,169 B2 7/2013 Bailie et al.
 D688,051 S 8/2013 Toll
 D688,052 S 8/2013 Toll
 D688,477 S * 8/2013 Toll D6/354
 D688,478 S * 8/2013 Toll D6/354
 D688,479 S 8/2013 Toll
 D720,939 S * 1/2015 Toll D6/354
 D722,446 S 2/2015 Toll
 D724,329 S 3/2015 Toll
 D724,330 S 3/2015 Toll
 2002/0117880 A1 8/2002 Ladson
 2003/0034678 A1 2/2003 Farré
 2003/0038515 A1 2/2003 Martin et al.
 2003/0067195 A1 4/2003 Sylvester
 2003/0071498 A1 4/2003 Yu
 2005/0006932 A1 1/2005 Laidlaw
 2007/0069557 A1 3/2007 Toll
 2007/0102970 A1 5/2007 Wallace
 2007/0200399 A1 8/2007 Riondato
 2008/0265636 A1 10/2008 Toll
 2009/0079237 A1 3/2009 Riondato
 2010/0109392 A1 5/2010 Toll
 2011/0298253 A1 12/2011 Toll
 2012/0086246 A1 4/2012 Belliveau
 2015/0239515 A1 8/2015 Toll

FOREIGN PATENT DOCUMENTS

JP 2011-143734 7/2011
 JP 2012-162255 8/2012
 WO 99/14103 3/1999
 WO 2006015731 2/2006
 WO 2007/038692 4/2007
 WO 2014/035972 2/2011
 WO 2013/134253 9/2013

OTHER PUBLICATIONS

U.S. Appl. No. 29/484,042, filed Jul. 29, 2014 with the following characterization: Alter, Lloyd. "No—Nose Bicycle Seats: Are They The Answer to Erectile Dysfunction and Prostate . . ." Tree Hugger., Sep. 17, 2010 [online], [retrieved on Jul. 19, 2014]. Retrieved from the Internet <URL: <http://www.treehugger.com/bikes/no-nose—bicycle—seats—are—they—the-answer—to-erectile-dysfunction-and-prostate—problems—among—cyclists.html>>.
 U.S. Appl. No. 29/484,039, filed Jul. 29, 2014 with the following characterization: Demerly, Tom. "ISM Adamo Time Trial and Racing 2 Saddles: The Triathlon Saddle Evolved . . ." Just Tri Talk., Feb. 27, 2013 [online], [retrieved on Jul. 19, 2014]. Retrieved from the Internet <URL: <http://justtritalk.com/ism-adamo-time-trial-and-racing-2-saddles-the-triathlon-saddle-evolved/>>.
 Ilan Leibovitch, Yoram Mor, "The Vicious Cycling: Bicycling Related Urogenital Disorders", European Urology 47, pp. 277-287 (2005).
 Eddy Randrup, M.D., and Neil Baum, M.D., "Bicycle Riding as a Cause for Erectile Dysfunction", www.medicalsexuality.org, pp. 26-27, (Nov. 2000).
 S. J. Jeong, K. Park, J. D. Moon, and SB Ryu, "Bicycle Saddle Shape affects penile blood flow", International Journal of Impotence Research, 14, 513-517 (2002).
 Ian R. Spears, Neil K. Cummins, Zoe Brenchley, Claire Donahue, Carl! Turnbull, Shona Burton, and Gabrielle A. Macho, "The Effect of Saddle Design on Stresses in the Perineum during Cycling", Medical Science Sports Exercise, vol. 35, No. 9, pp. 1620-1625 (2003).
 Eadric Bressel, and Brad J. Larson, "Bicycle Seat Designs and Their Effect on Pelvic Angle, Trunk Angle, and Comfort", Medical Science Sports Exercise, vol. 35, No. 2, pp. 327-332 (2003).
 G. Breda, M.D., N. Piazza, M.D., V. Bernardi, M.D., E. Lundardon, M.D., and Adara Caruso, M.D., "Development of New Geometric

(56)

References Cited

OTHER PUBLICATIONS

Bicycle Saddle for the Maintenance of Genital—Perineal Vascular Perfusion,” *Journal of Sexual Medicine*, vol. 2, Issue 5, pp. 605-611 (Sep. 2005).

Brian D. Lowe, Steven M. Schrader, and Michael J. Breitenstein, “Effect of Bicycle Saddle Designs on the Pressure to the Perineum of the Bicyclist,” *Medical Science Sports Exercise*, vol. 36, No. 6, pp. 1055-1062 (2004).

Eadric Bressel, John Cronin, and Alicia Exeter, “Bicycle Seat Interface Pressure: Reliability, Validity, and Influence of Hand Position and Workload,” *Journal of Biomechanics*, vol. 38, Issue 6, pp. 1325-1331 (Jun. 2005).

Eadric Bressel, Tracey Reeve, Dan Parker, John Cronin, “Influence of Bicycle Seat Pressure on compression of the perineum: a MRI Analysis,” *Journal of Biomechanics* 40, pp. 198-202 (2007, Accepted Nov. 26, 2005).

Cited by Examiner in U.S. Appl. No. 29/539,813 on Jul. 25, 2016 with the following characterization: “Noseless Bicycle Saddles—What You Need to Know.” *Electro Heart Beats.*, Mar. 15, 2014 [online], [retrieved on Jul. 8, 2016]. Retrieved from the Internet <URL: <http://www.electroheartbeats.com/2014/03/noseless-bicycle-saddles-what-youneed.html>>.

Cited by the Examiner of U.S. Appl. No. 29/539,809 on Jul. 21, 2016 with the following characterization: “Saddles Part 3—ISM ADAMO.” *Bike Test Reviews*. Apr. 5, 2013 [online], [retrieved on Jul. 8, 2016]. Retrieved from the Internet <URL: <http://biketestreviews.com/saddles-part-3-ism-adamo/>>.

Cited by the Examiner of U.S. Appl. No. 29/539,809 on Jul. 21, 2016 with the following characterization: “Noseless Saddles—My Two Cents Worth.” *The Bike Noob.*, Jun. 30, 2011 [online], [retrieved on Jul. 8, 2016]. Retrieved from the Internet <URL: <http://bikenob.com/2011/06/30/noseless-saddles-my-two-cents-worth/>>.

* cited by examiner

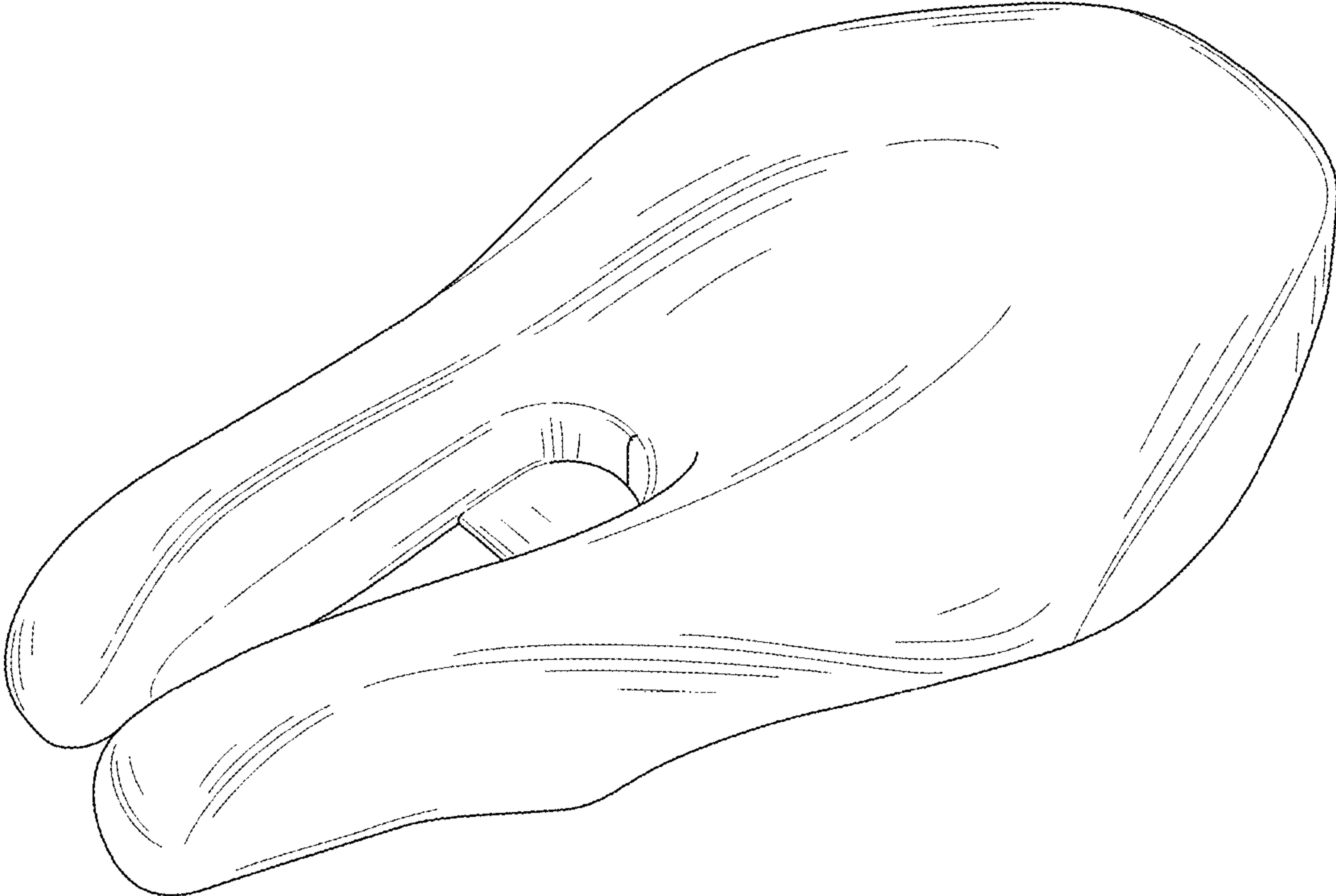

FIG. 1

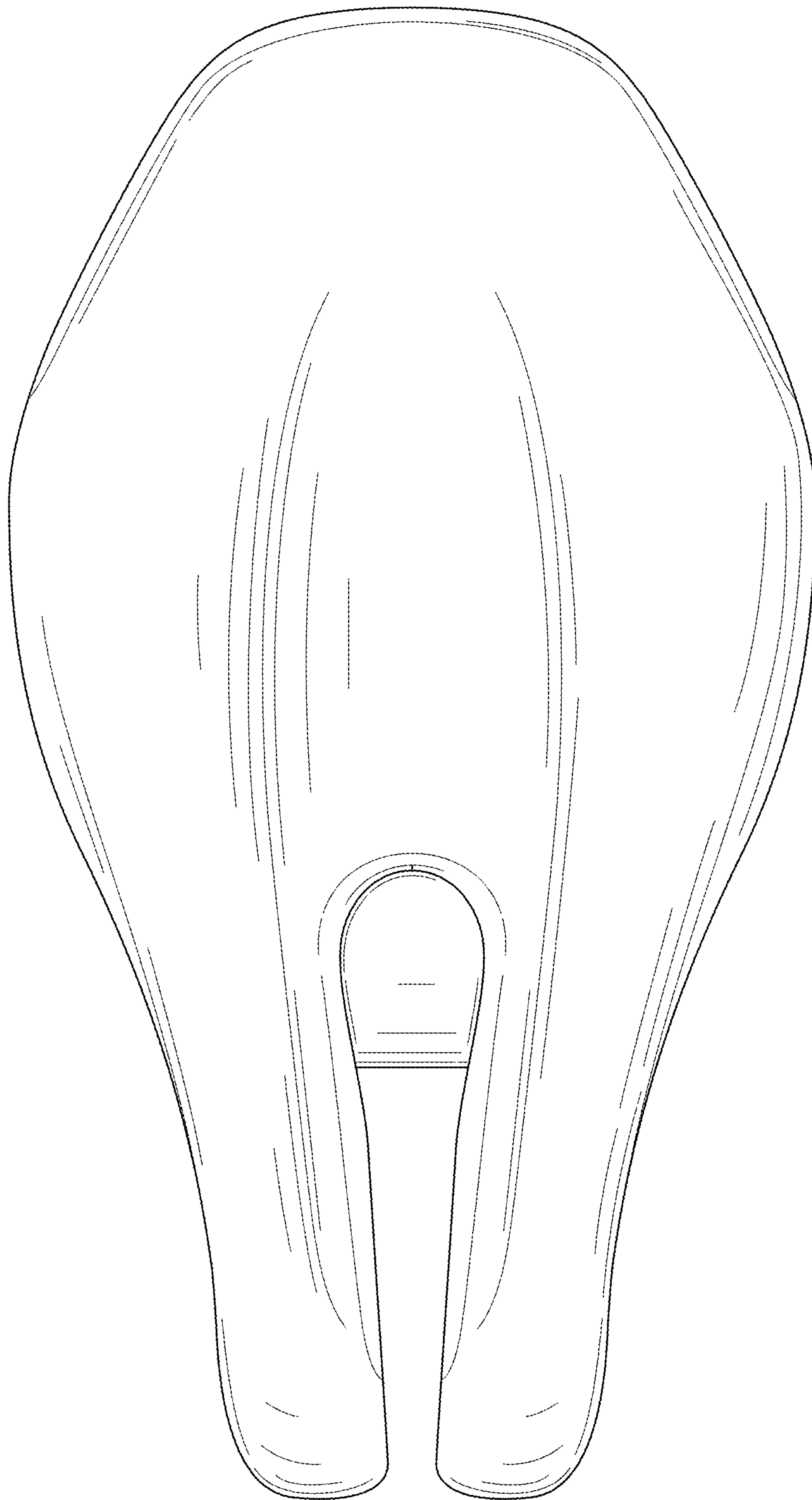

FIG. 2



FIG. 3



FIG. 4



FIG. 5

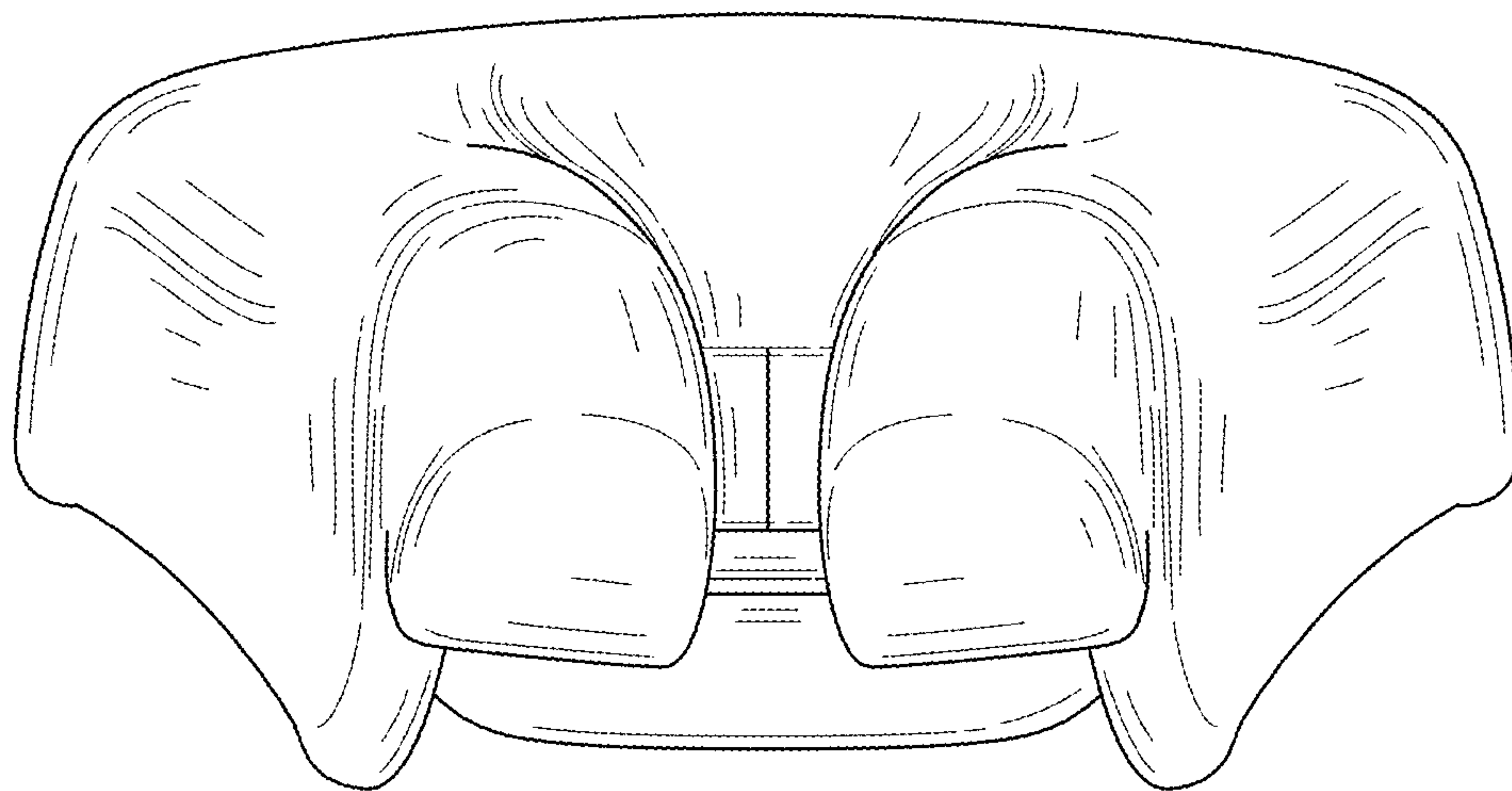

FIG. 6

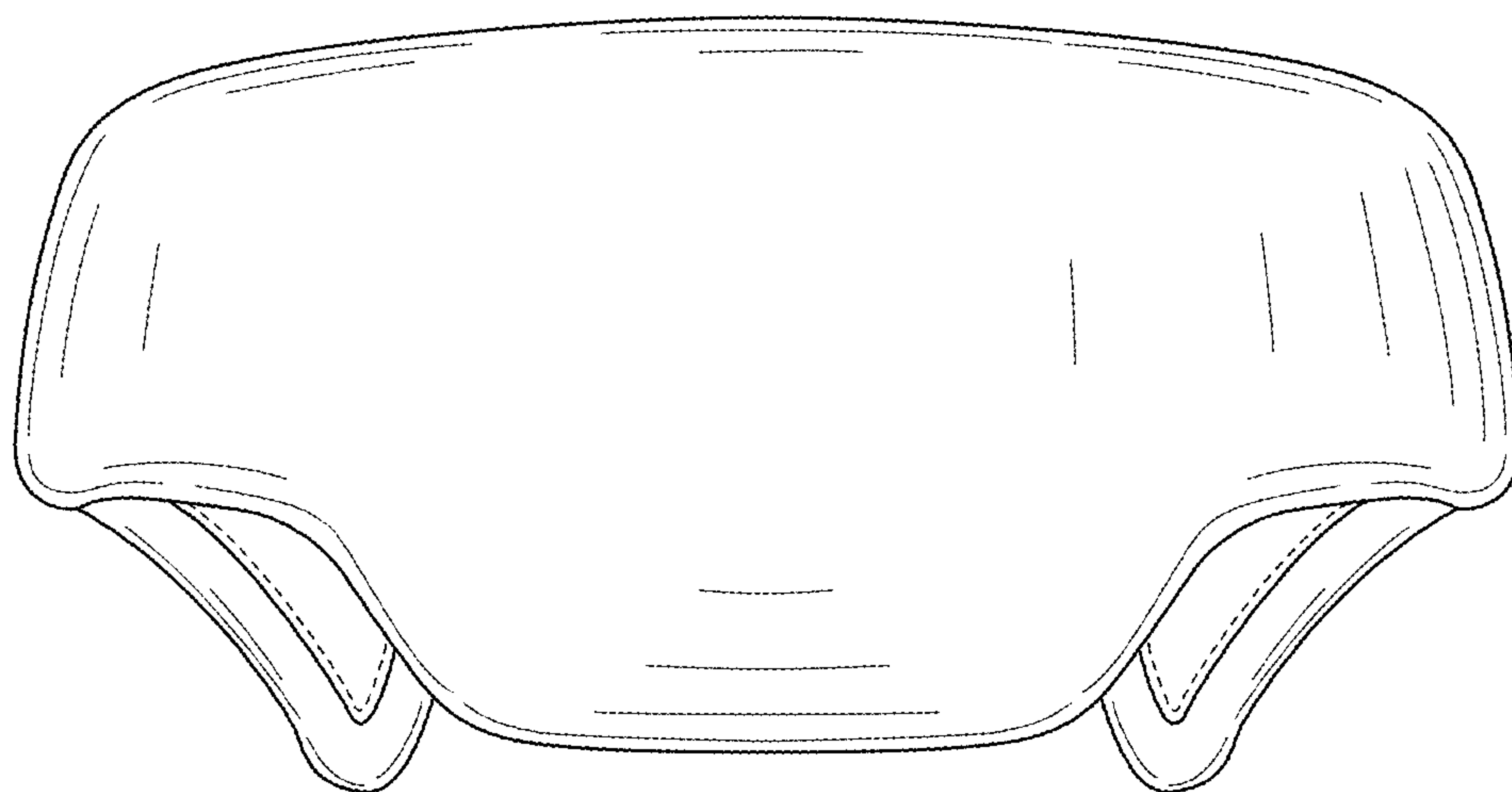

FIG. 7

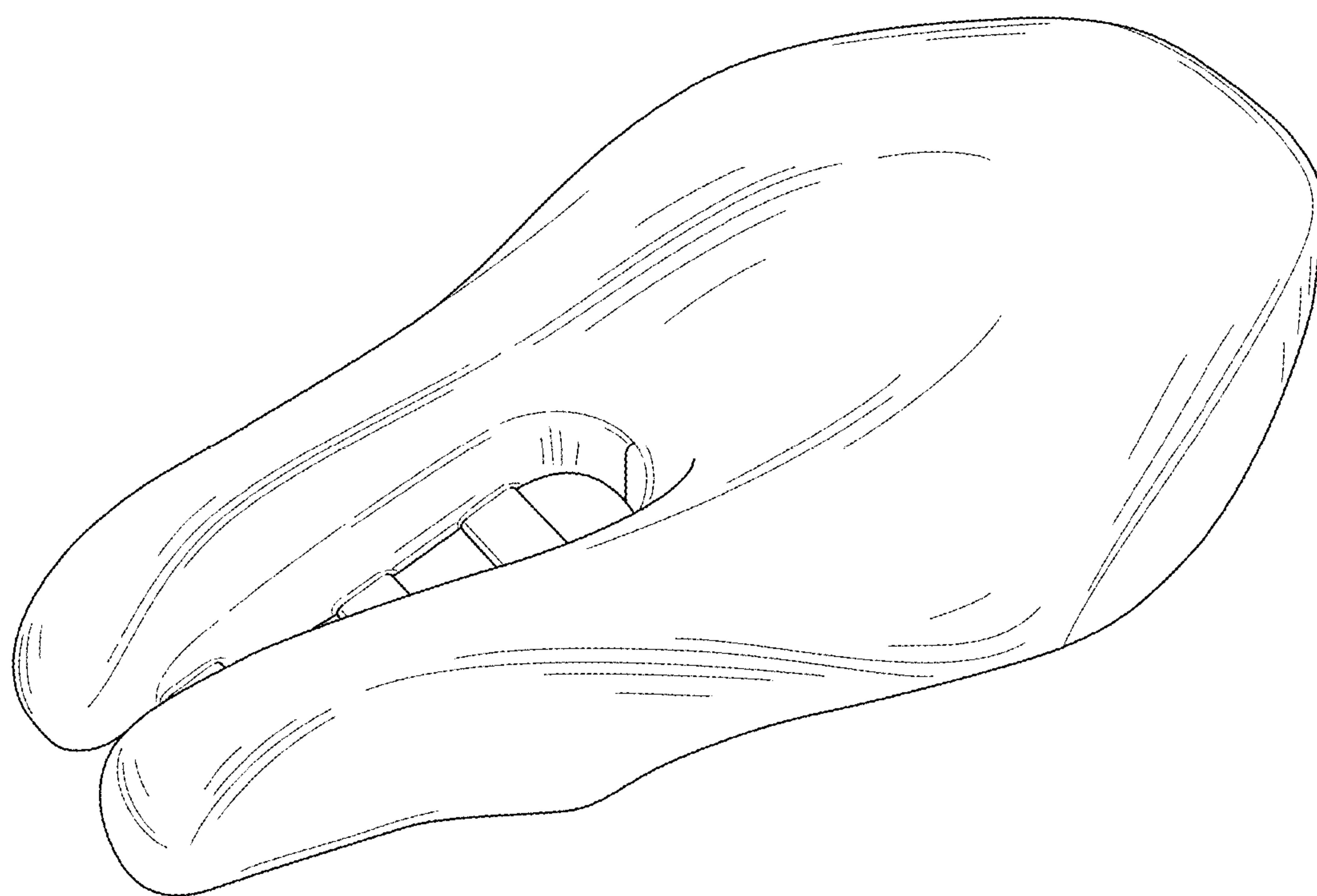

FIG. 8

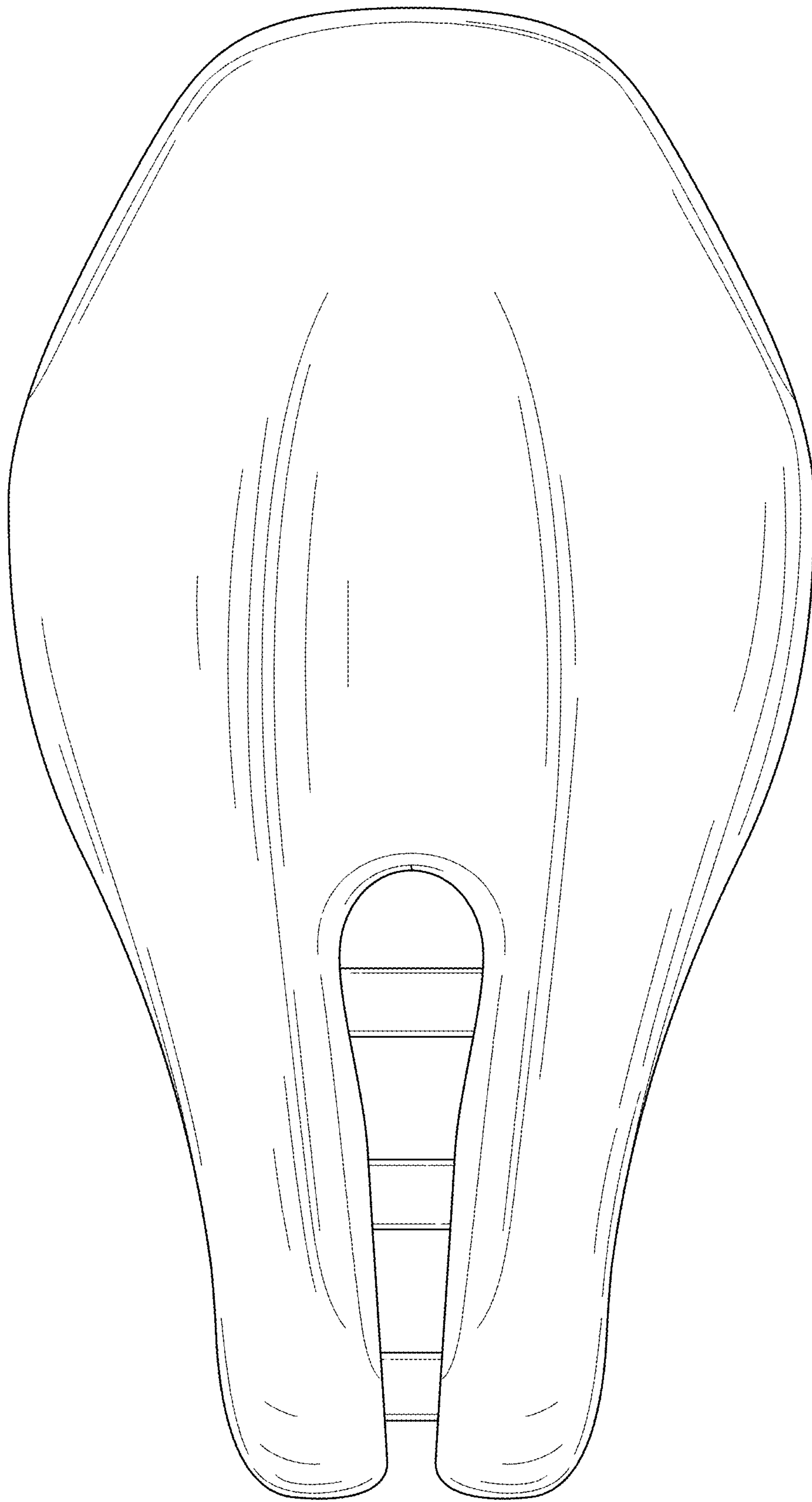

FIG. 9



FIG. 10



FIG. 11



FIG. 12

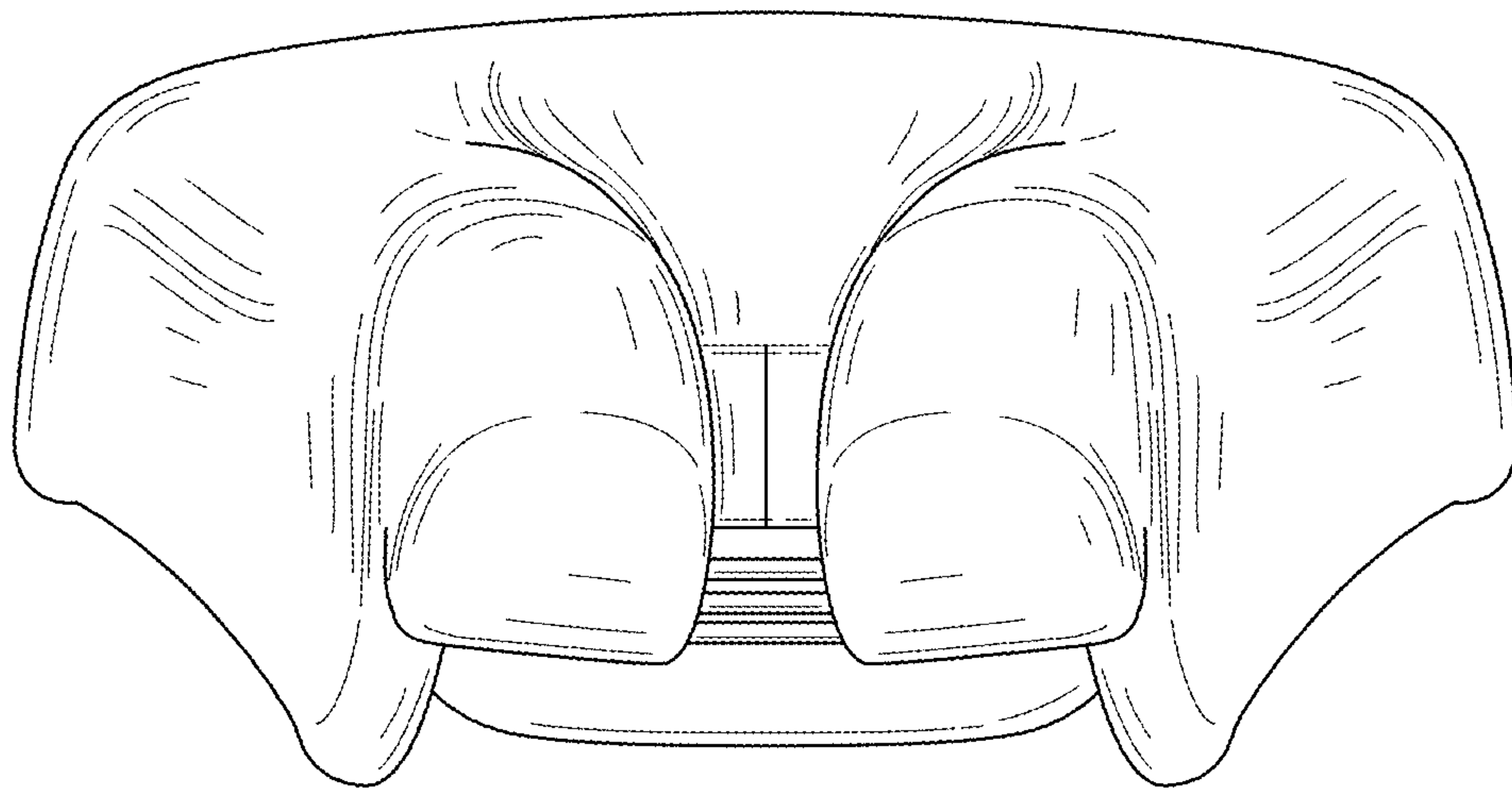

FIG. 13

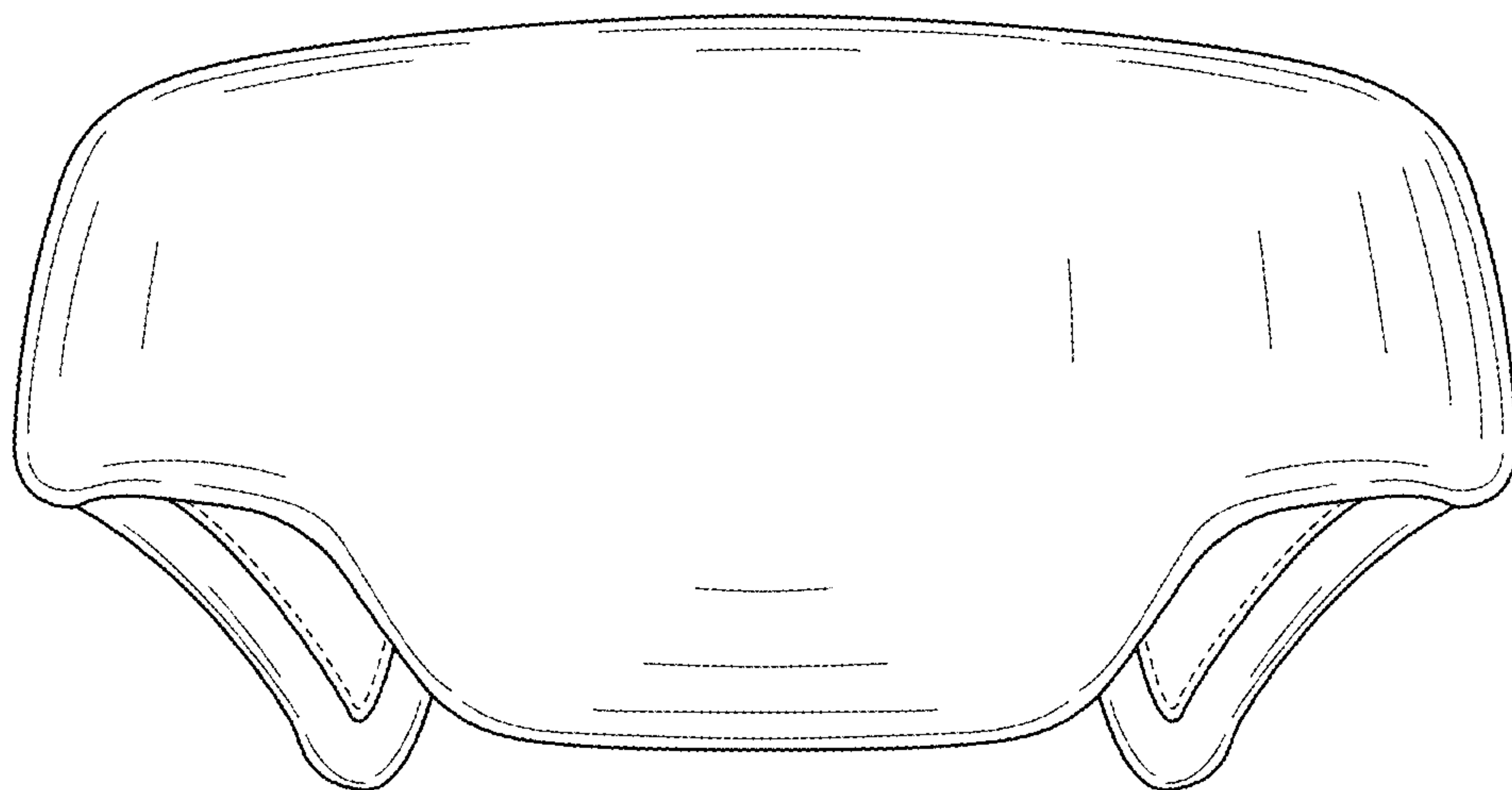

FIG. 14

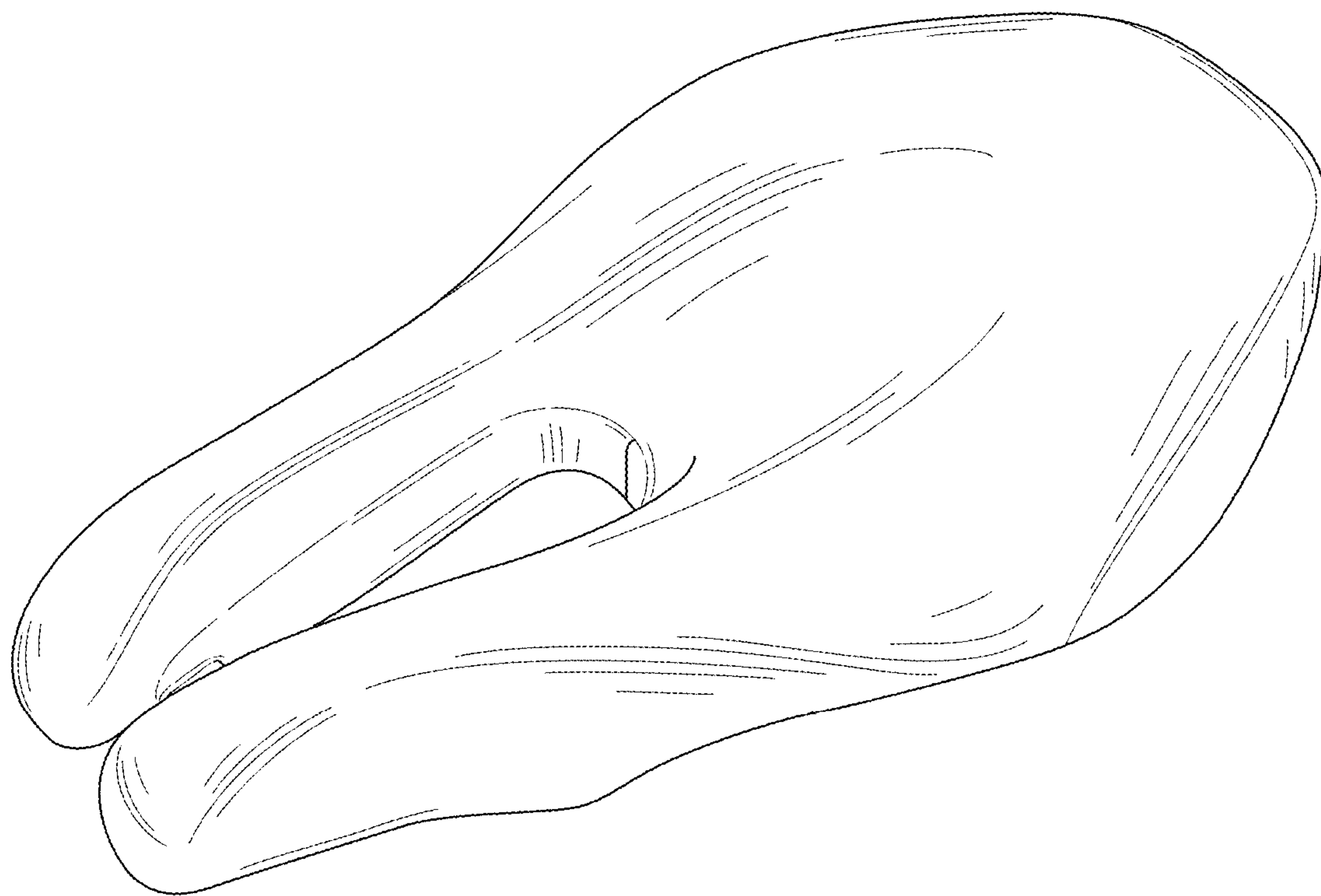

FIG. 15

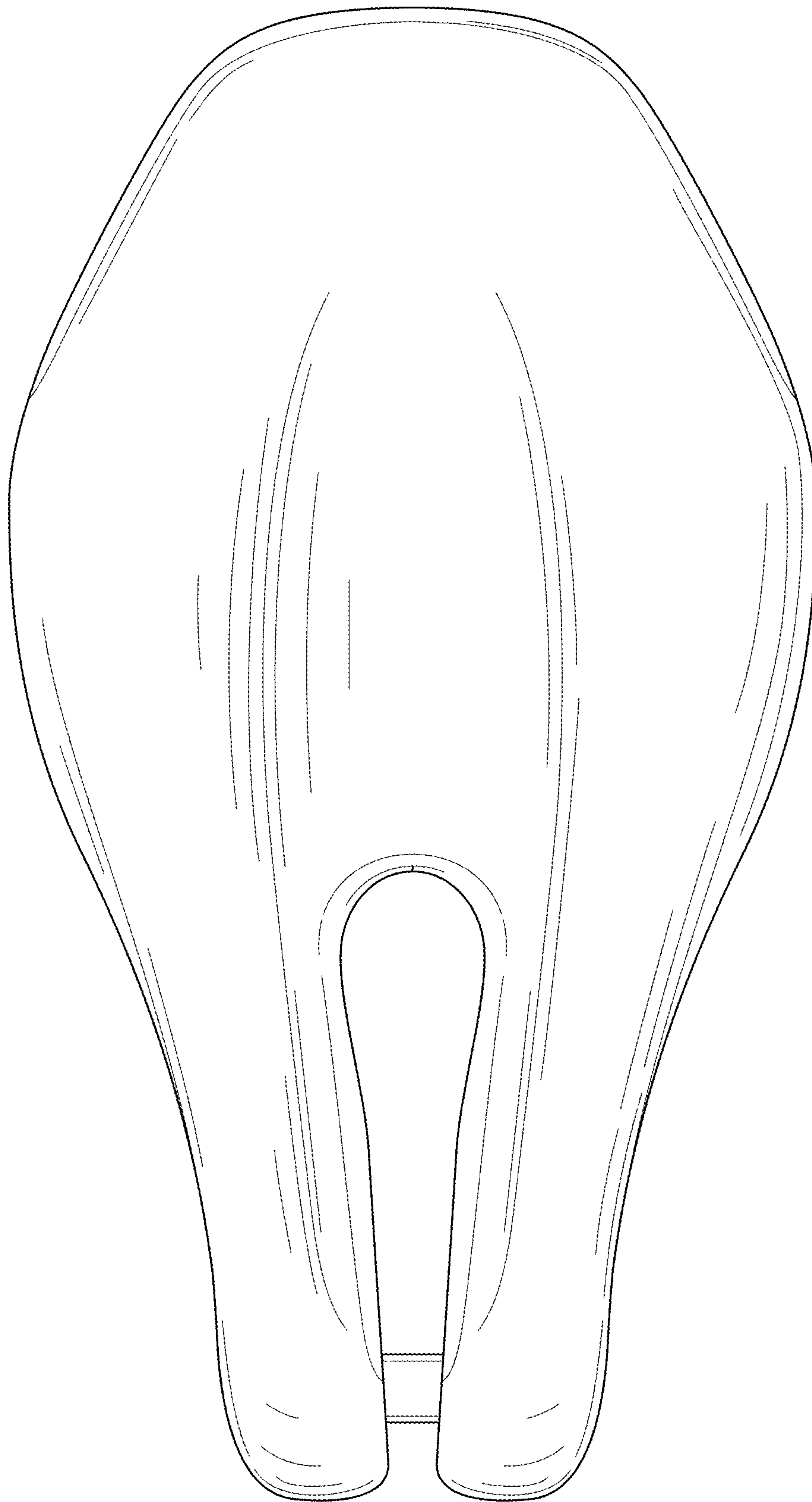

FIG. 16



FIG. 17



FIG. 18



FIG. 19

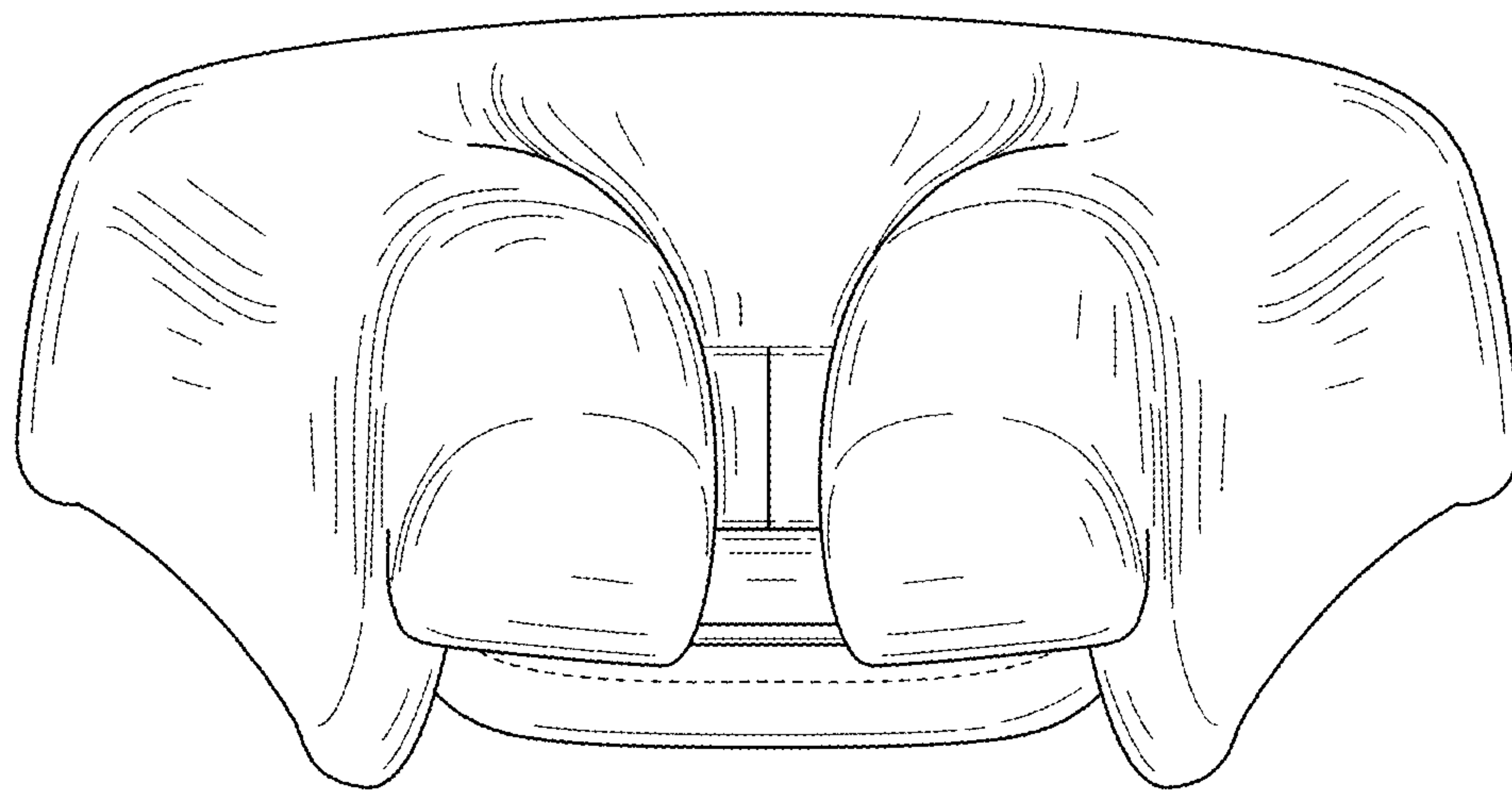

FIG. 20

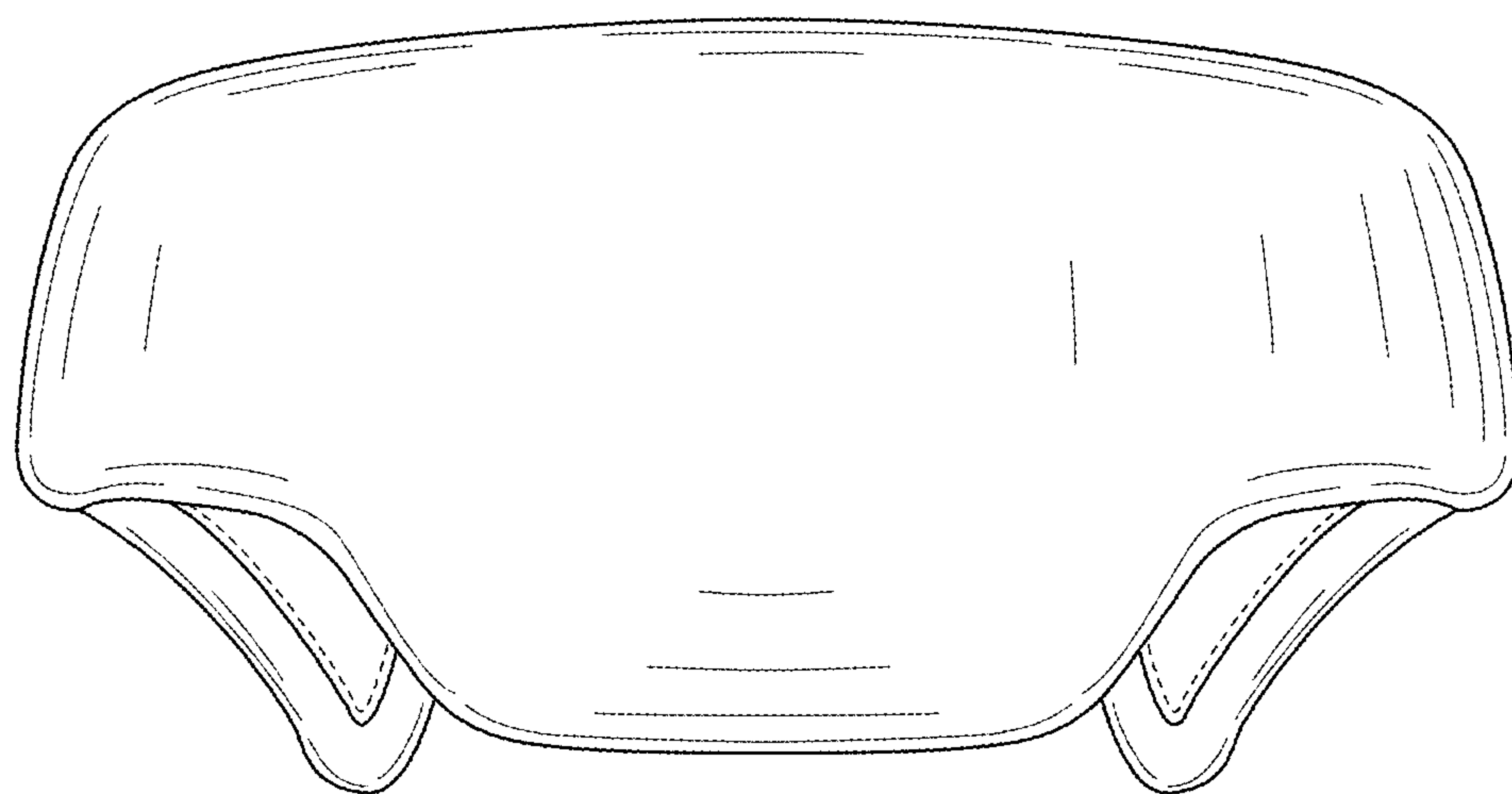

FIG. 21

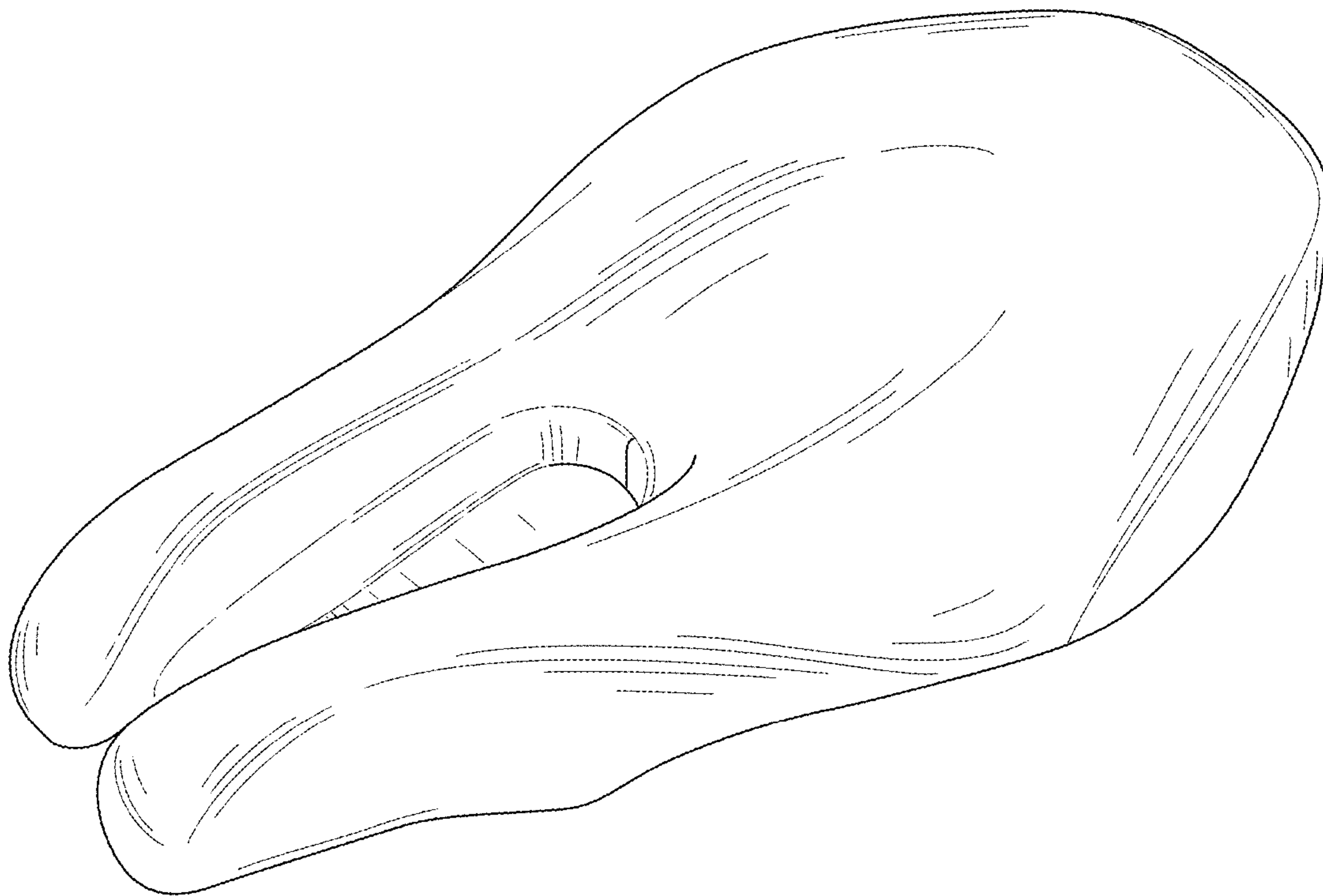

FIG. 22

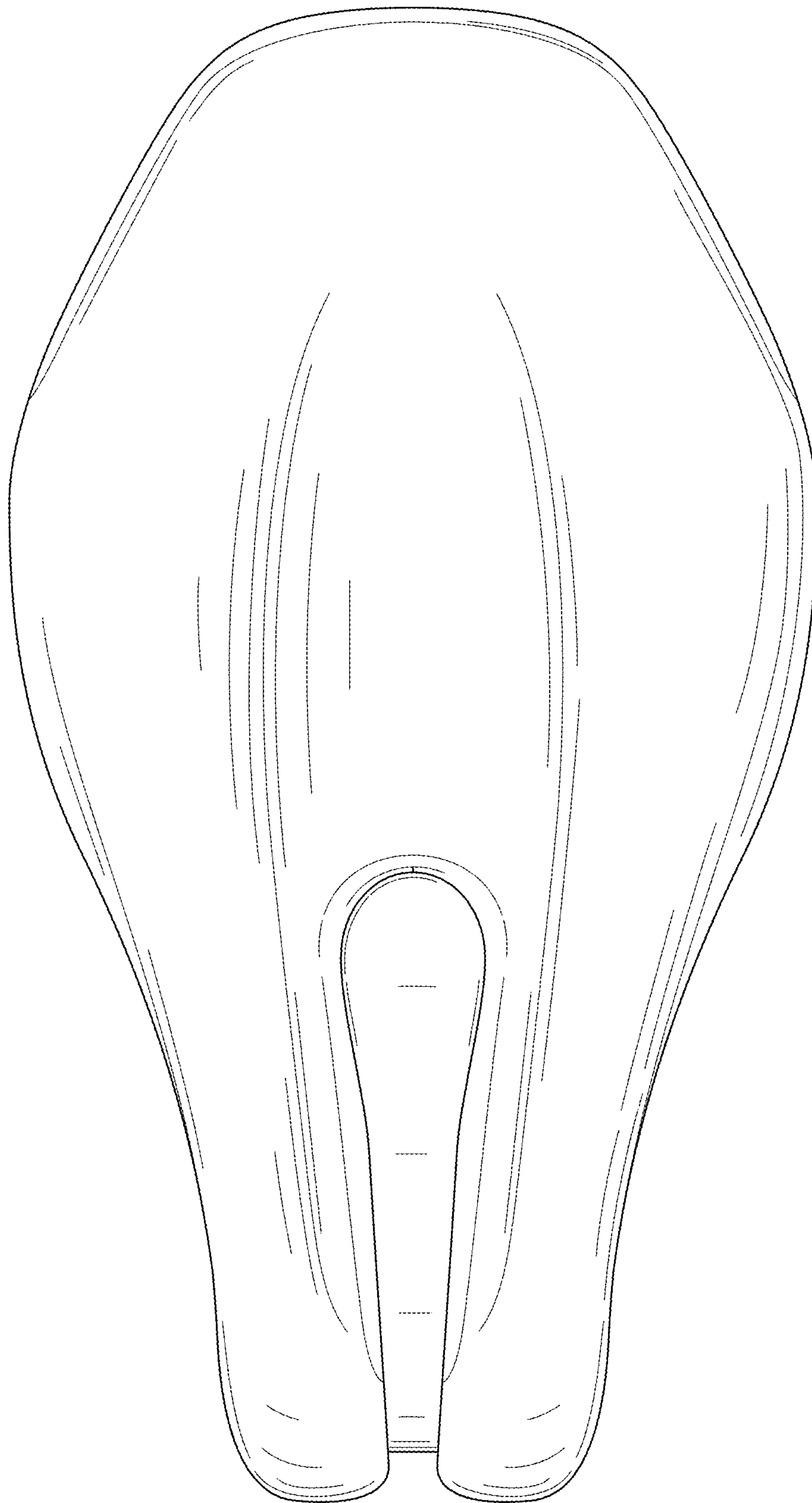

FIG. 23

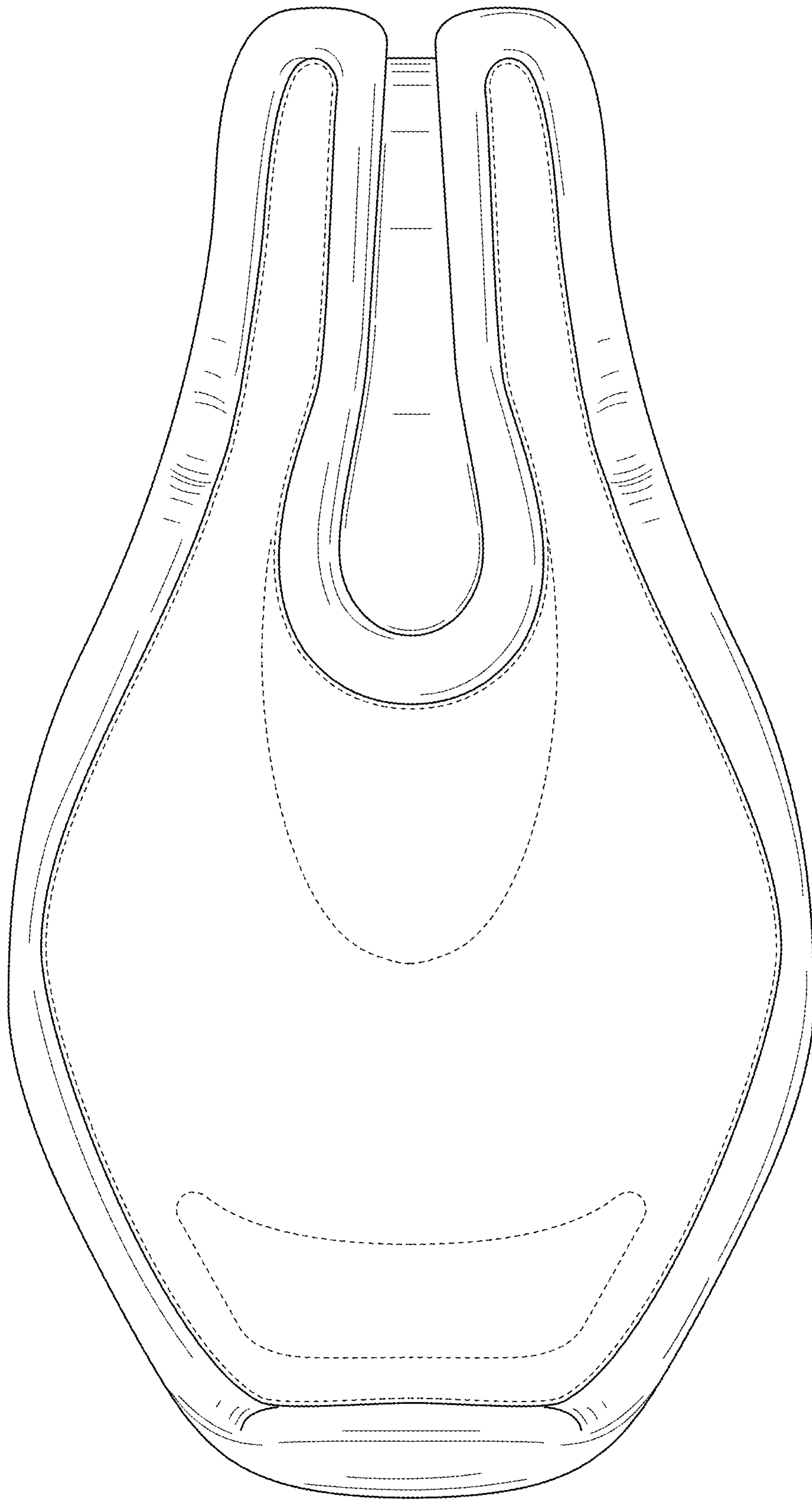

FIG. 24



FIG. 25



FIG. 26

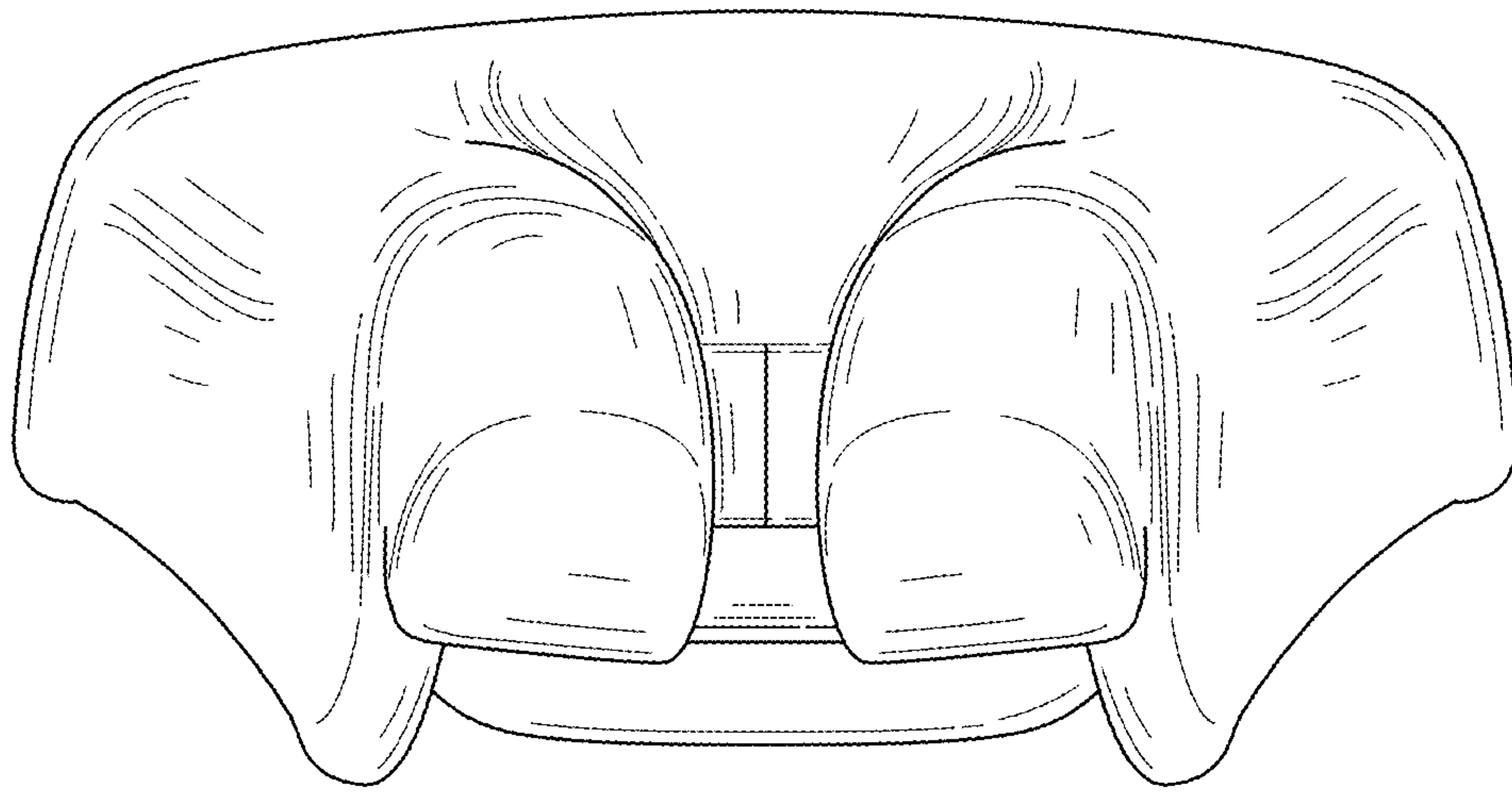

FIG. 27

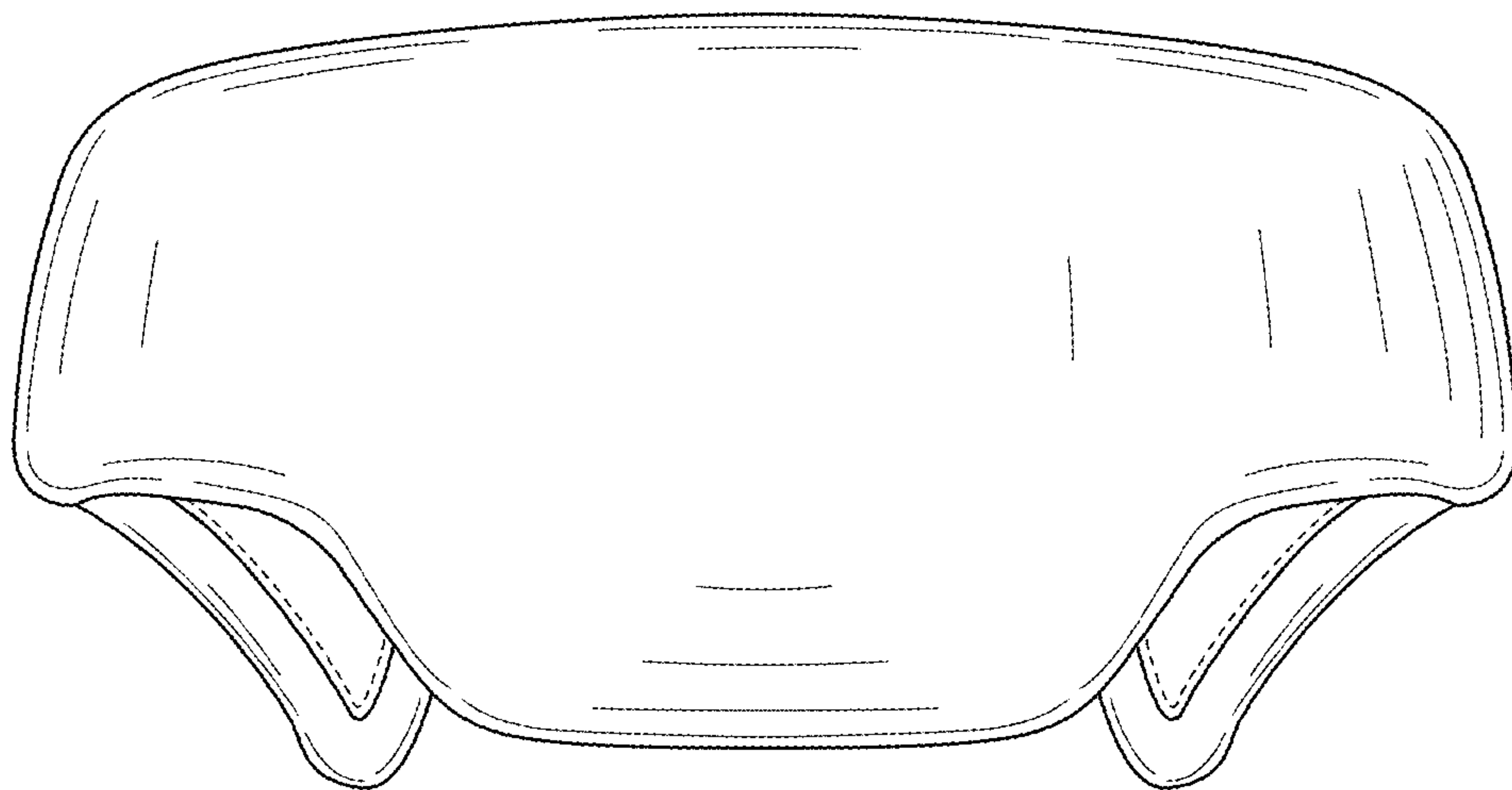

FIG. 28