



US00D767760S

(12) **United States Design Patent** (10) **Patent No.:** **US D767,760 S**  
**Suwito et al.** (45) **Date of Patent:** **\*\* Sep. 27, 2016**

(54) **TUNNELING TOOL FOR AN IMPLANTABLE MONITORING DEVICE**

D405,883 S \* 2/1999 Emerson ..... D24/133  
D708,324 S \* 7/2014 Schwarz ..... D24/133  
D708,741 S \* 7/2014 Harrison ..... D24/133  
D714,936 S \* 10/2014 Weber ..... D24/133

(71) Applicant: **BIOTRONIK SE & Co. KG**, Berlin (DE)

\* cited by examiner

(72) Inventors: **Wantjinarjo Suwito**, West Linn, OR (US); **Hannes Kraetschmer**, West Linn, OR (US); **Jeffrey A. von Arx**, Lake Oswego, OR (US); **Dirk Muessig**, West Linn, OR (US); **Larry Stotts**, Tigard, OR (US)

*Primary Examiner* — Robert M Spear  
*Assistant Examiner* — Eliza Bennett-Hattan  
(74) *Attorney, Agent, or Firm* — Buchanan Ingersoll & Rooney PC

(73) Assignee: **BIOTRONIK SE & Co. KG**, Berlin (DE)

(57) **CLAIM**  
The ornamental design for a tunneling tool for an implantable monitoring device, as shown and described.

(\*\*) Term: **15 Years**

(21) Appl. No.: **29/526,740**

**DESCRIPTION**

(22) Filed: **May 13, 2015**

(51) **LOC (10) Cl.** ..... **24-02**

(52) **U.S. Cl.**  
USPC ..... **D24/141; D21/441**

(58) **Field of Classification Search**  
USPC ..... D24/108, 112, 117, 118, 133, 135, 137, D24/138, 146, 141, 111, 113, 127, 143, 148, D24/179, 216, 152, 153, 154, 176; D8/4, D8/29.1, 29.2, 30, 31, 39; D17/10, 13; D23/266  
CPC ..... A61B 17/1604; A61B 17/3468; A61B 2017/0409; A61B 17/15; A61C 8/0089; A61N 1/05; A61M 25/0662; A61M 27/002; A61M 2210/0681; A61M 25/0105; A61M 31/00; A61M 2025/0004; A61M 2025/0006  
See application file for complete search history.

FIG. 1 is a top, front, distal side (i.e. perspective) view of the tunneling tool for an implantable monitoring device with a distal end on the left side and a proximal end on the right side;  
FIG. 2 is a front side view of the tunneling tool for an implantable monitoring device with a distal end on the left side and a proximal end on the right side;  
FIG. 3 is a rear side view of the tunneling tool for an implantable monitoring device with a distal end on the right side and a proximal end on the left side;  
FIG. 4 is a distal front view of the tunneling tool for an implantable monitoring device;  
FIG. 5 is a proximal rear view of the tunneling tool for an implantable monitoring device;  
FIG. 6 is a top view of the tunneling tool for an implantable monitoring device; and,  
FIG. 7 is a bottom view of the tunneling tool for an implantable monitoring device.  
The broken lines in the drawing depict environmental subject matter only and form no part of the claimed design.

(56) **References Cited**

**U.S. PATENT DOCUMENTS**

D389,912 S \* 1/1998 Emerson ..... D24/133  
D398,995 S \* 9/1998 Muller ..... D24/133

**1 Claim, 7 Drawing Sheets**

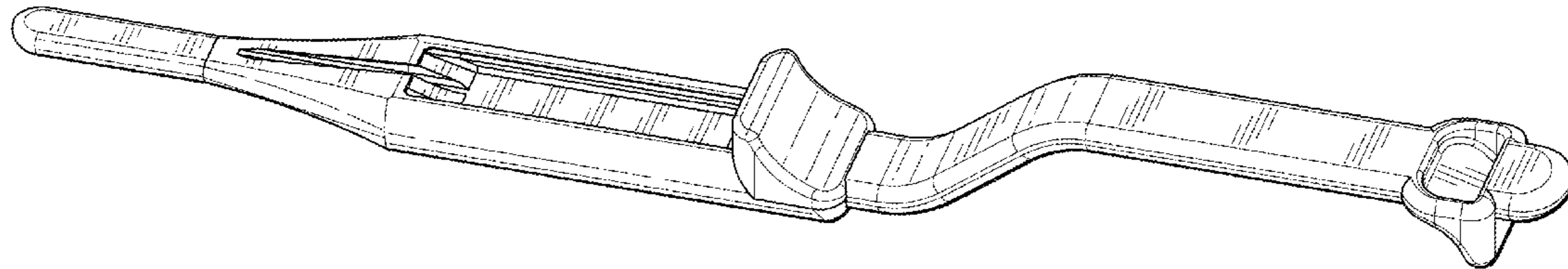

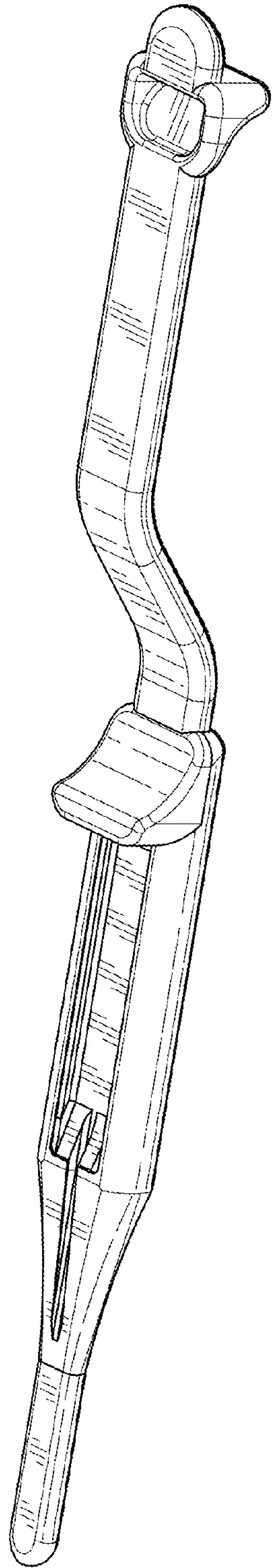

Fig. 1

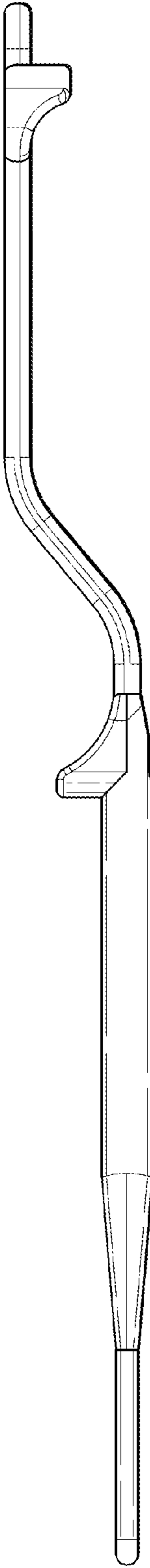

Fig. 2

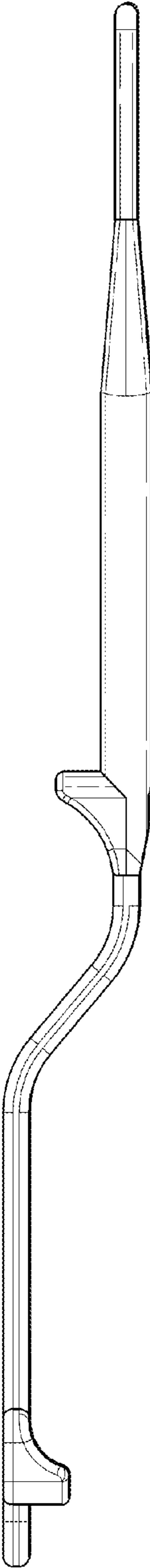

Fig. 3

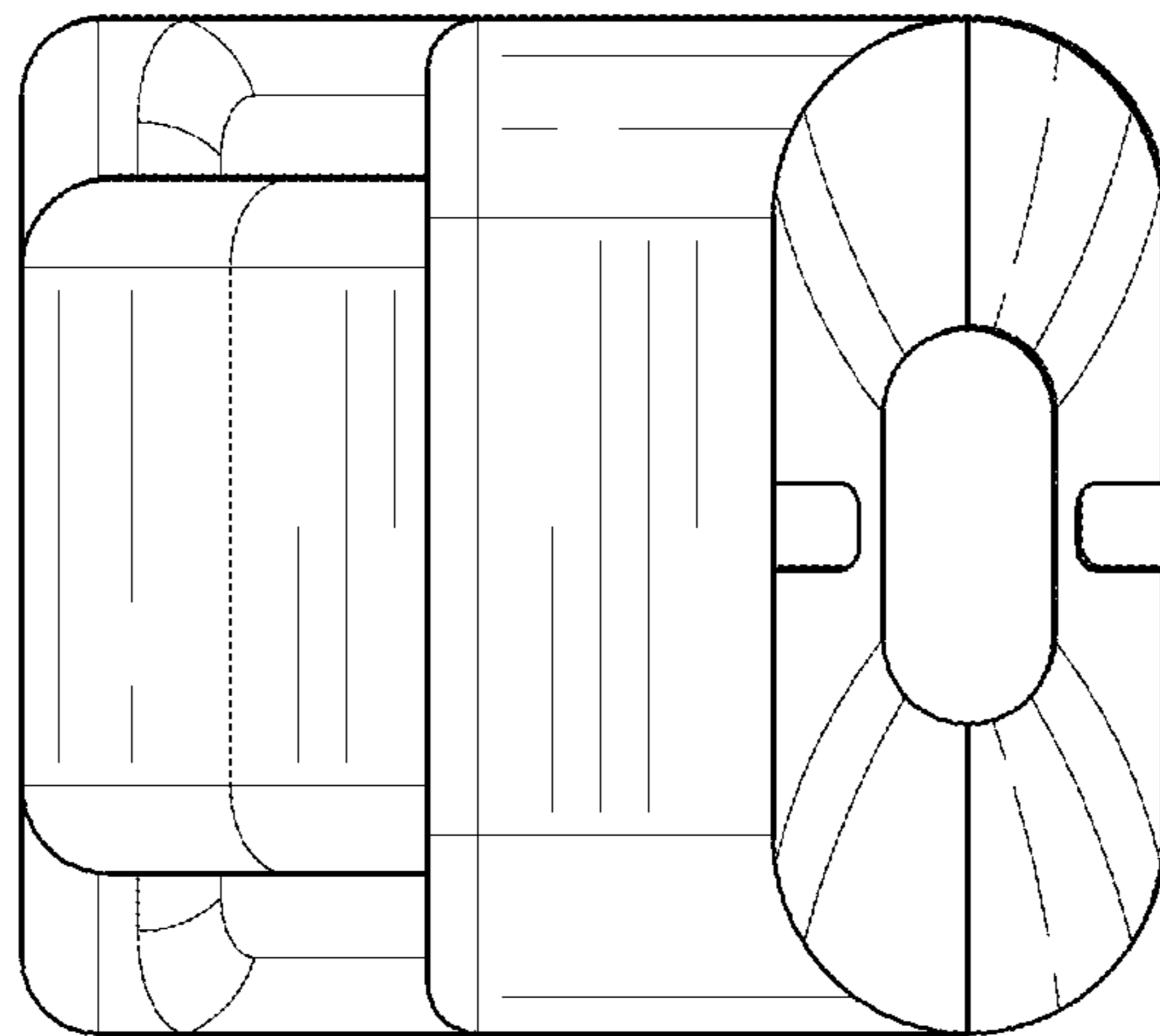

Fig. 4

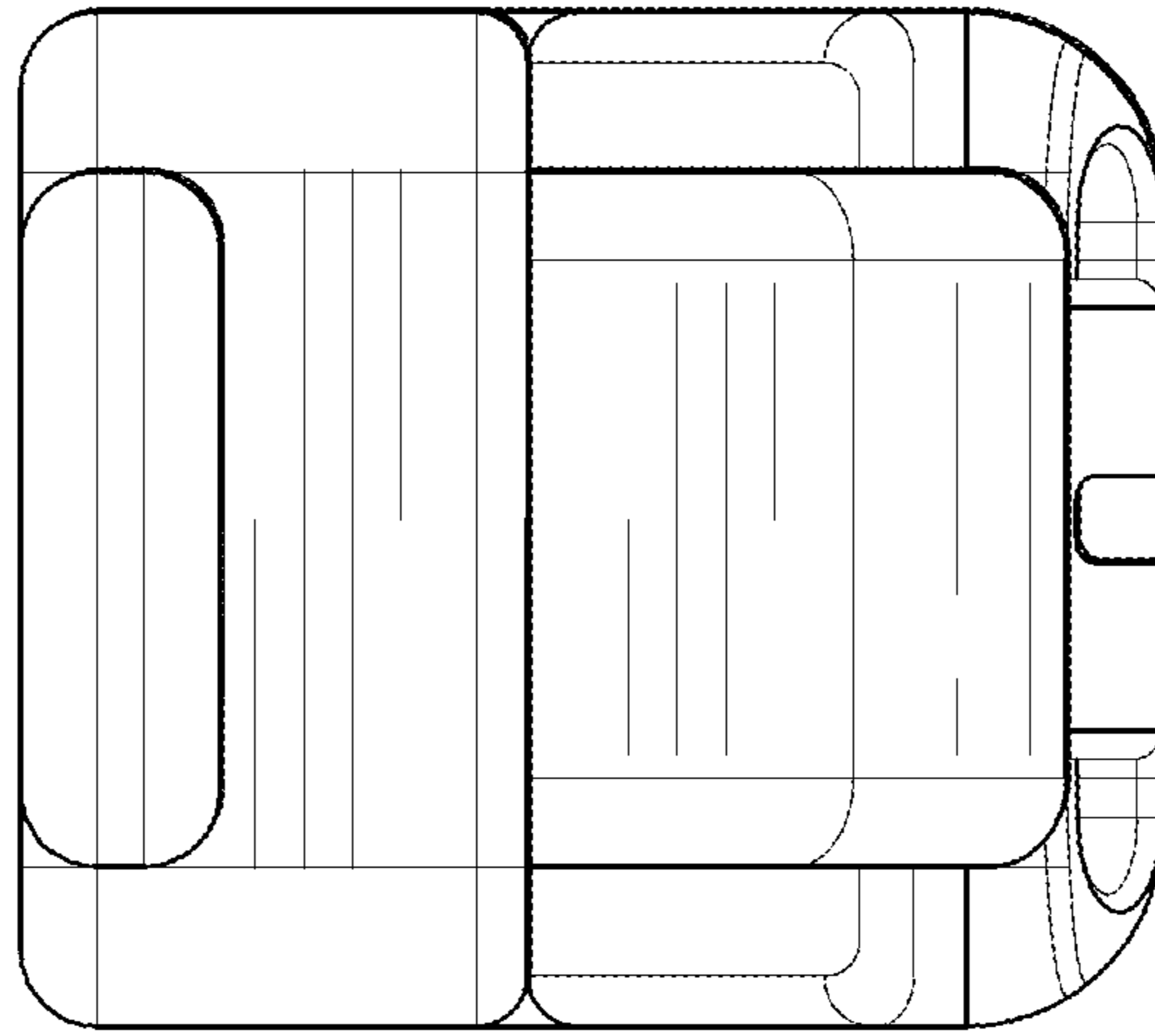

Fig. 5

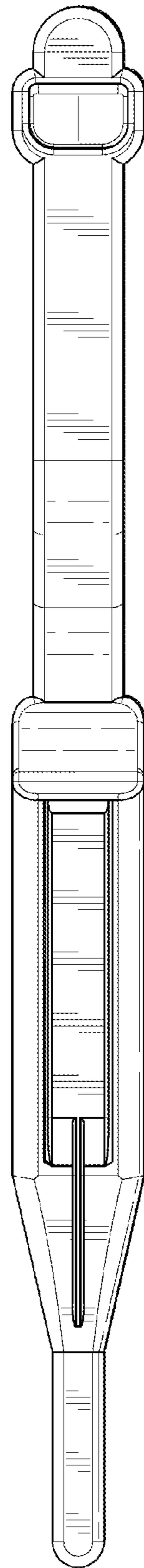

Fig. 6

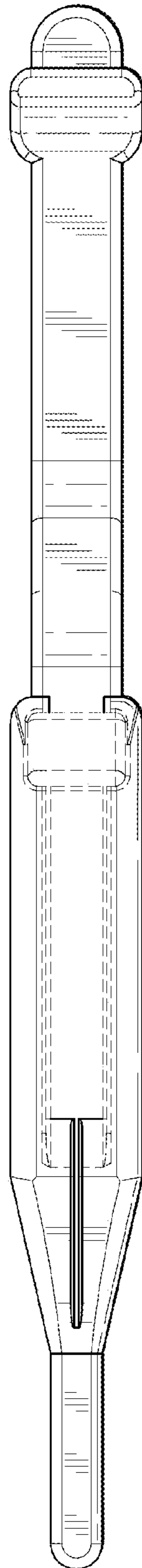

Fig. 7