

US00D767637S

(12) **United States Design Patent** (10) **Patent No.:** **US D767,637 S**
Pappathopoulos (45) **Date of Patent:** **** Sep. 27, 2016**

(54) **PUMP CASING COMPONENT**

(71) Applicant: **Weir Slurry Group, Inc.**, Madison, WI (US)

(72) Inventor: **Chris Pappathopoulos**, Sun Prairie, WI (US)

(73) Assignee: **WEIR SLURRY GROUP, INC.**, Madison, WI (US)

(**) Term: **15 Years**

(21) Appl. No.: **29/535,038**

(22) Filed: **Aug. 3, 2015**

(51) **LOC (10) Cl.** **15-02**

(52) **U.S. Cl.**
USPC **D15/7**

(58) **Field of Classification Search**
USPC D15/7-9; D23/231, 232, 225; 417/60, 417/235, 265, 321, 355, 358, 363, 359, 417/410.1, 415-416, 405, 900; 60/408, 60/412; 184/26-37; 415/140-147, 200; 123/495, 509; 137/565.34
CPC F02M 37/04; F02M 37/14
See application file for complete search history.

(56) **References Cited**

U.S. PATENT DOCUMENTS

D368,913 S *	4/1996	Wightley	D15/7
D381,339 S *	7/1997	Wightley	D15/7
D609,248 S *	2/2010	Foreman	D15/7
D609,250 S *	2/2010	Liu	D15/7
D610,165 S *	2/2010	Glaves	D15/7
D616,902 S *	6/2010	Foreman	D15/7
D659,718 S	5/2012	Seidel		
9,057,385 B2	6/2015	Burgess et al.		
D740,327 S *	10/2015	Naruoka	D15/5
D742,420 S *	11/2015	Sullivan	D15/7
2014/0271162 A1	9/2014	Karl et al.		

OTHER PUBLICATIONS

Brochure entitled **Warman® Centrifugal Slurry Pumps**, Weir Minerals North America, 2008.

Examiner's Report issued by the Canadian Intellectual Property Office regarding Canadian Patent Application No. 166645, dated May 6, 2016, 2 pages.

Office Actions issued by Korean Intellectual Property Office regarding Korean Design Application No. 30/2016-0005130, dated Jun. 6, 2016, 4 pages.

Notices of Allowance issued by Korean Intellectual Property Office regarding Korean Design Application No. 30-2016-0005130, dated Jun. 9, 2016, 6 pages.

Notice of Allowance issued by the Chinese Patent Office regarding Chinese Design Application No. 201630033499.6, dated May 27, 2016, 6 pages.

Examination Report issued by the Government of India Patent Office regarding Indian Design Application No. 279951, dated Jun. 2, 2016, 2 pages.

Examination Report issued by the Government of India Patent Office regarding Indian Design Application No. 279950, dated Jun. 3, 2016, 2 pages.

Examination Report issued by the Government of India Patent Office regarding Indian Design Application No. 279952, dated Jun. 3, 2016, 2 pages.

Examination Report issued by the Government of India Patent Office regarding Indian Design Application No. 279953, dated Jun. 3, 2016, 2 pages.

Notification of Reasons for Refusal and Written Order (English translation) issued from the Japanese Patent Office regarding Japanese Design Application No. 2016-002102, mailed Jul. 1, 2016, 5 pages.

* cited by examiner

Primary Examiner — Ralf Seifert

(74) *Attorney, Agent, or Firm* — Haynes and Boone, LLP

(57) **CLAIM**

The ornamental design for a pump casing component, as shown and described.

DESCRIPTION

FIG. 1 is a perspective view of a pump casing component showing my new design according to a first embodiment; FIG. 2 is a front elevational view of the first embodiment; FIG. 3 is a rear elevational view of the first embodiment; FIG. 4 is a right side elevational view of the first embodiment; FIG. 5 is a left side elevational view of the first embodiment;

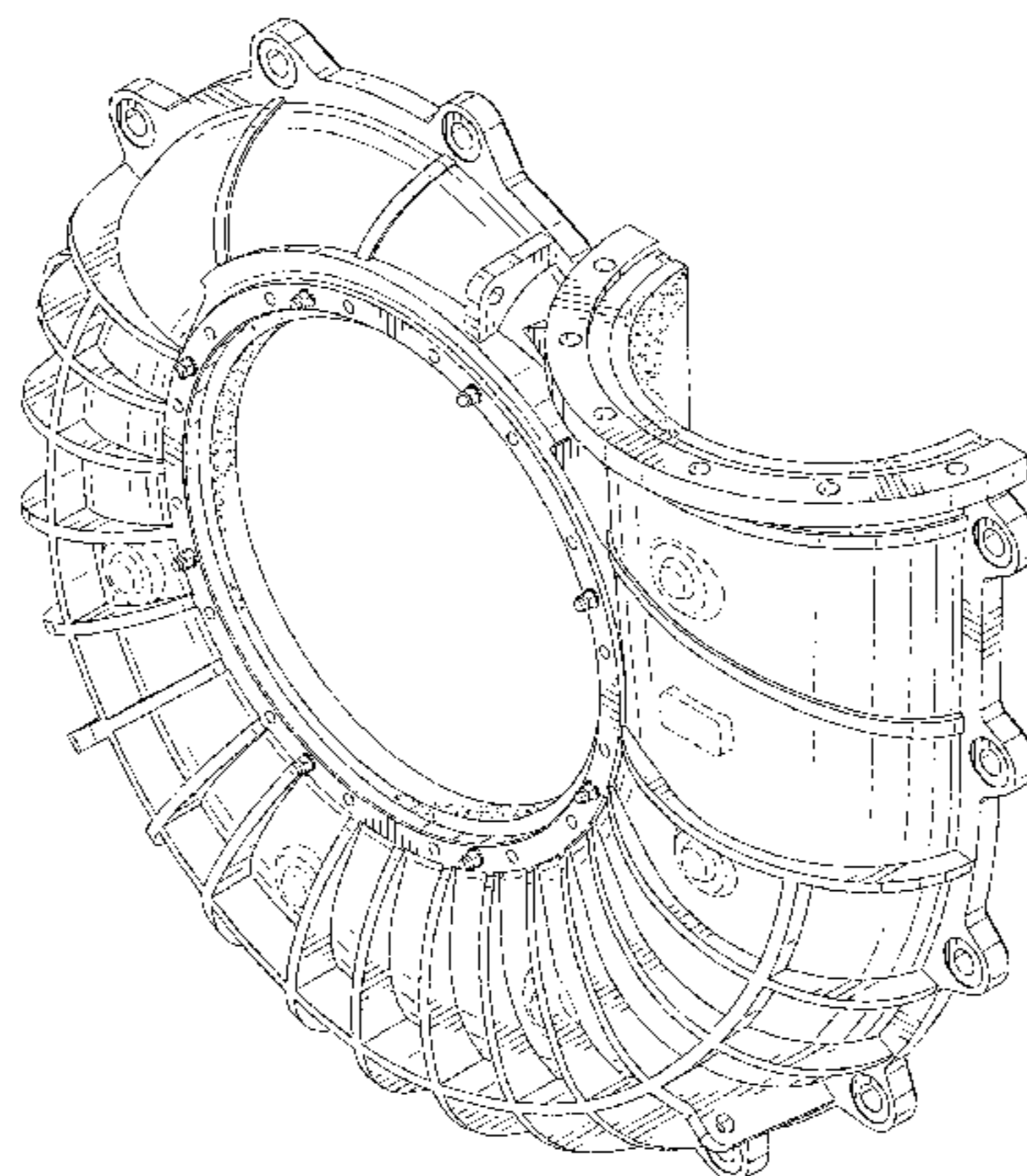

FIG. 6 is a top plan view of the first embodiment;
FIG. 7 is a bottom plan view of the first embodiment;
FIG. 8 is another perspective view of the first embodiment;
FIG. 9 is a perspective view of the pump casing component showing my new design according to a second embodiment;
FIG. 10 is a front elevational view of the second embodiment;
FIG. 11 is a rear elevational view of the second embodiment;
FIG. 12 is a right side elevational view of the second embodiment;
FIG. 13 is a left side elevational view of the second embodiment;
FIG. 14 is a top plan view of the second embodiment;
FIG. 15 is a bottom plan view of the second embodiment;
FIG. 16 is another perspective view of the second embodiment;
FIG. 17 is a perspective view of the pump casing component showing my new design according to a third embodiment;
FIG. 18 is a front elevational view of the third embodiment;
FIG. 19 is a rear elevational view of the third embodiment;
FIG. 20 is a right side elevational view of the third embodiment;
FIG. 21 is a left side elevational view of the third embodiment;

FIG. 22 is a top plan view of the third embodiment;
FIG. 23 is a bottom plan view of the third embodiment;
FIG. 24 is another perspective view of the third embodiment;
FIG. 25 is a perspective view of the pump casing component showing my new design according to a fourth embodiment;
FIG. 26 is a front elevational view of the fourth embodiment;
FIG. 27 is a rear elevational view of the fourth embodiment;
FIG. 28 is a right side elevational view of the fourth embodiment;
FIG. 29 is a left side elevational view of the fourth embodiment;
FIG. 30 is a top plan view of the fourth embodiment;
FIG. 31 is a bottom plan view of the fourth embodiment;
and,
FIG. 32 is another perspective view of the fourth embodiment.

The broken lines in FIGS. 1, 2, 4-7, 9, 10, 12-15, and 17-32 form no part of the claimed design.

The different surface shadings (line shading and stippled shading) in FIGS. 1-3, 6, 8-11, 14, and 16 are used to indicate contrasting materials.

1 Claim, 24 Drawing Sheets

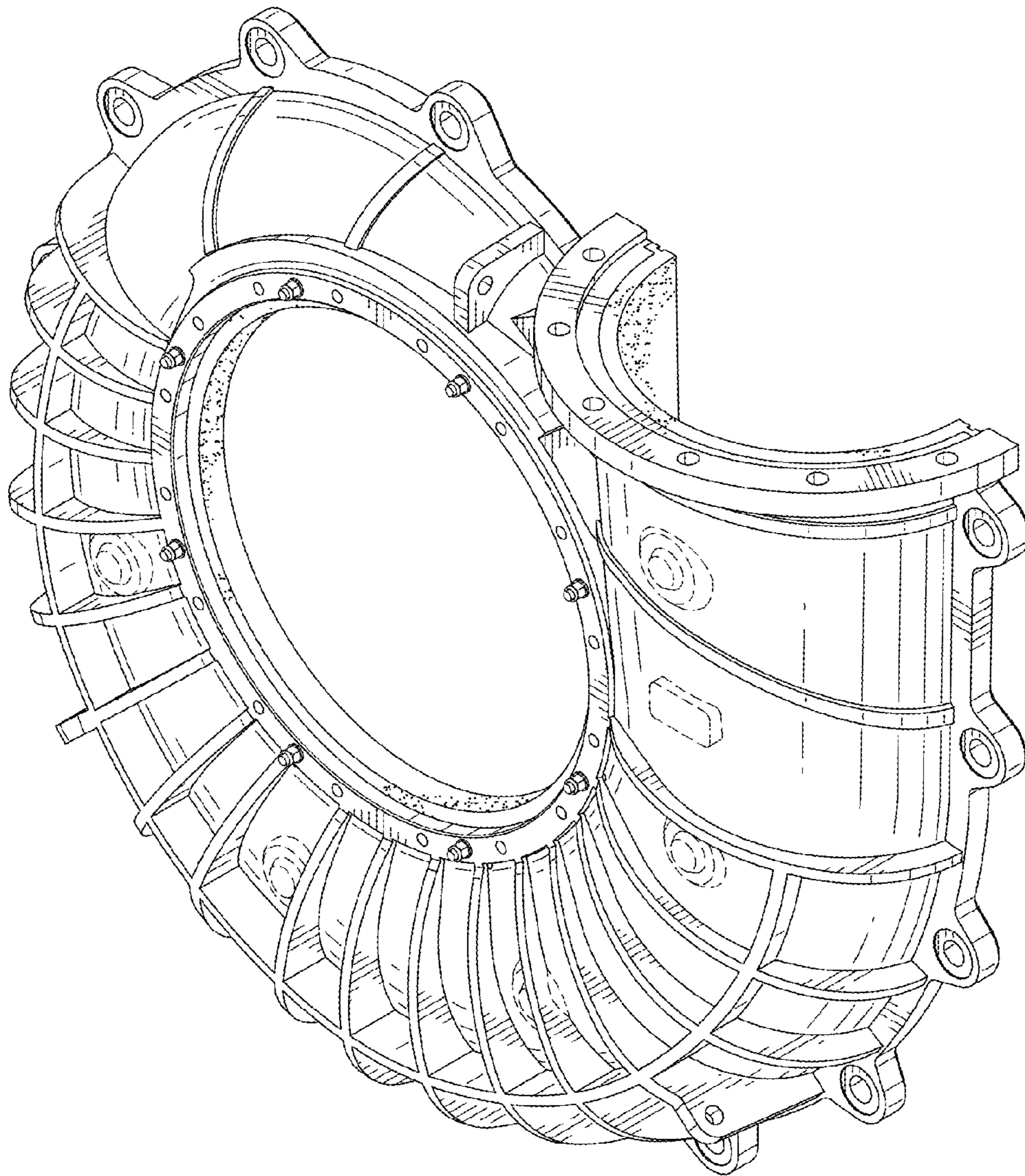

Fig. 1

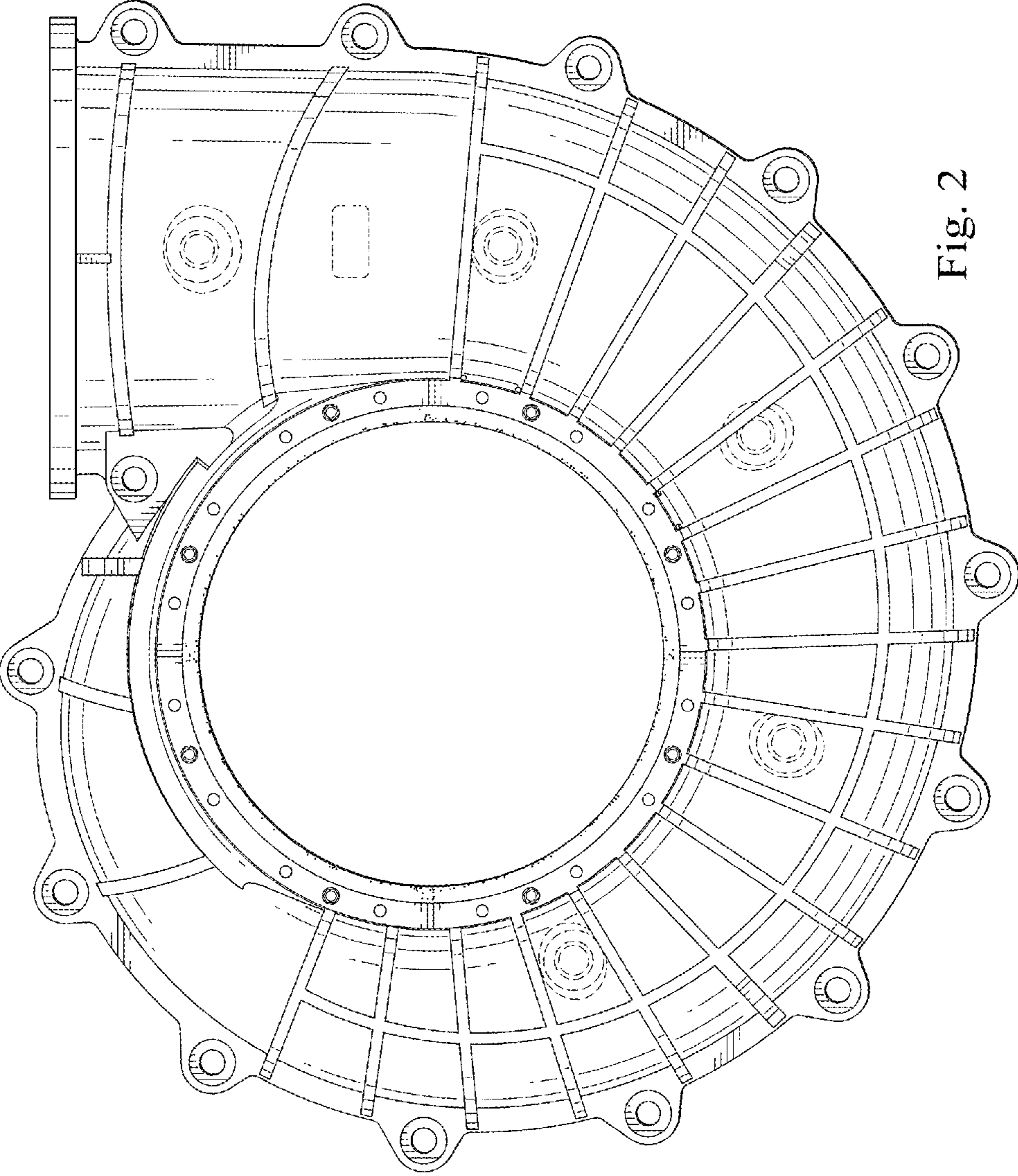

Fig. 2

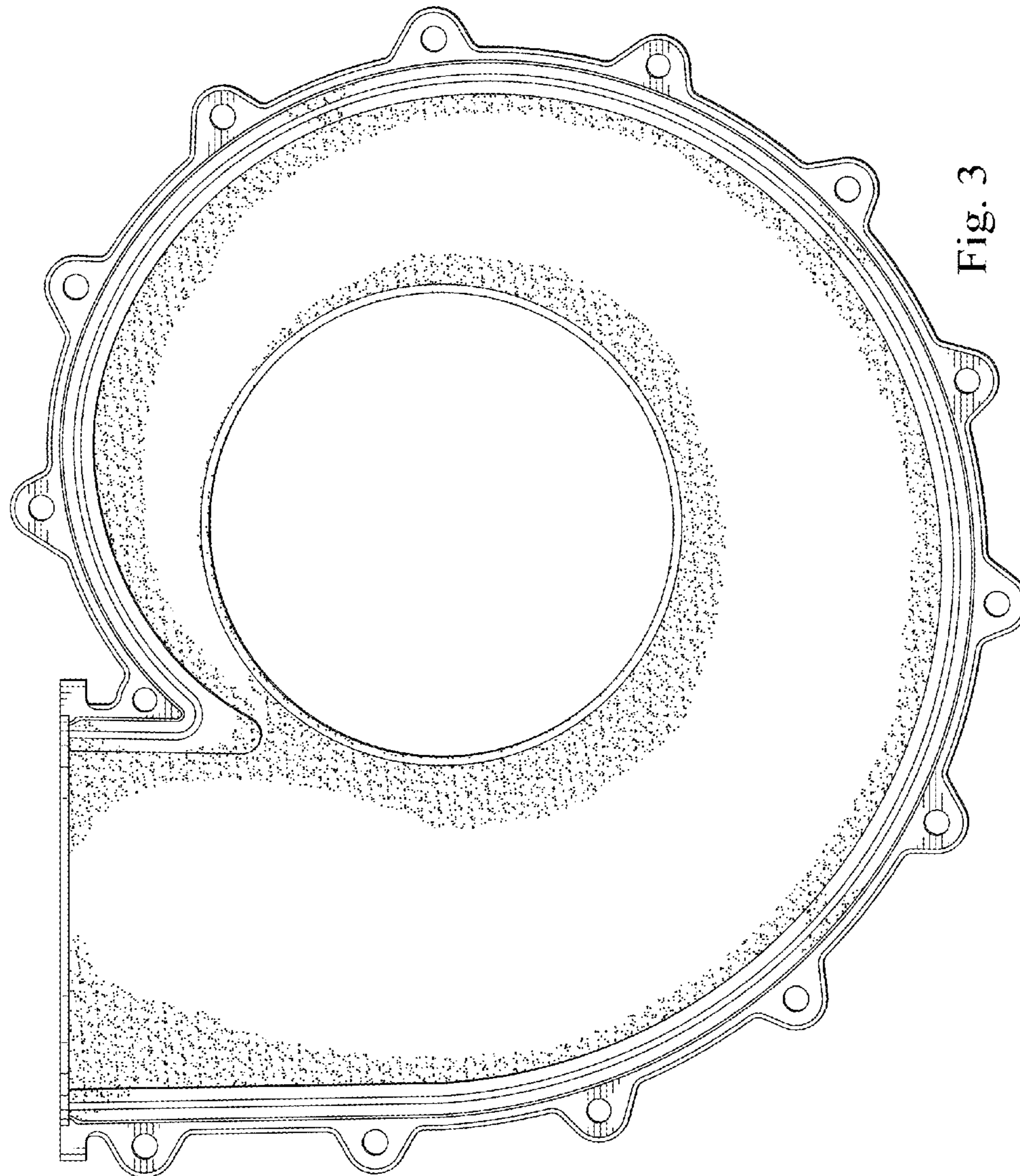

Fig. 3

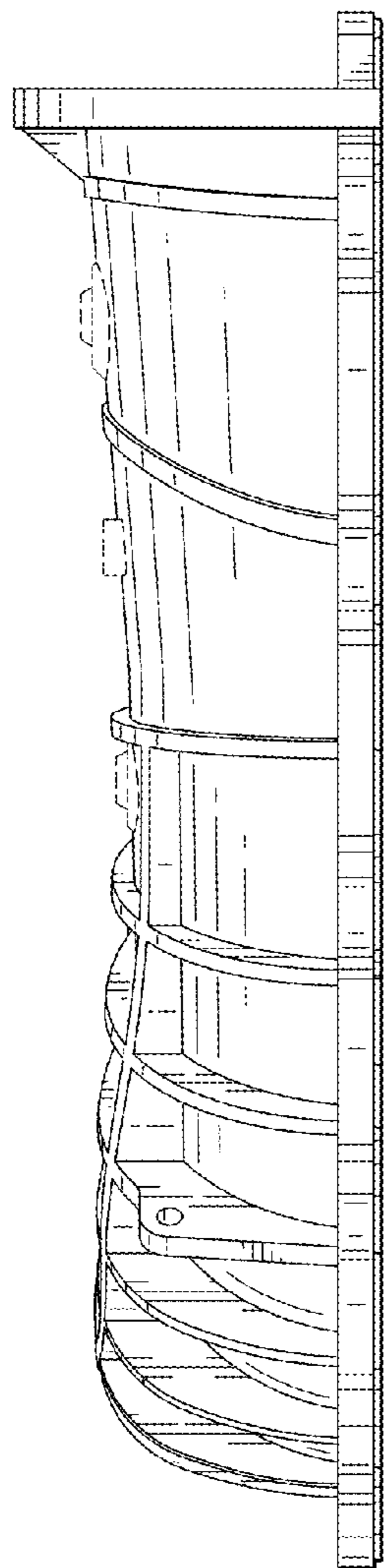

Fig. 4

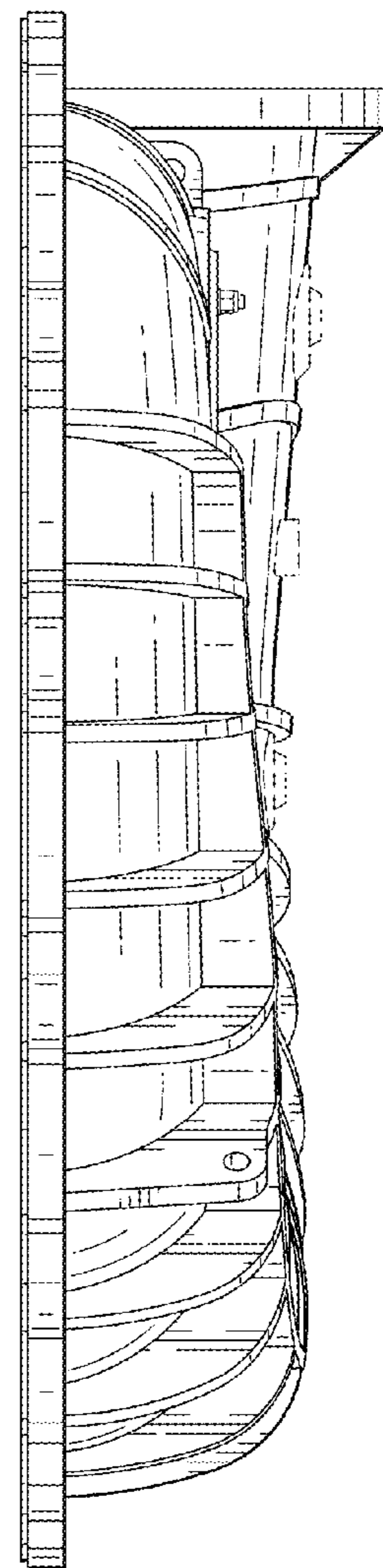

Fig. 5

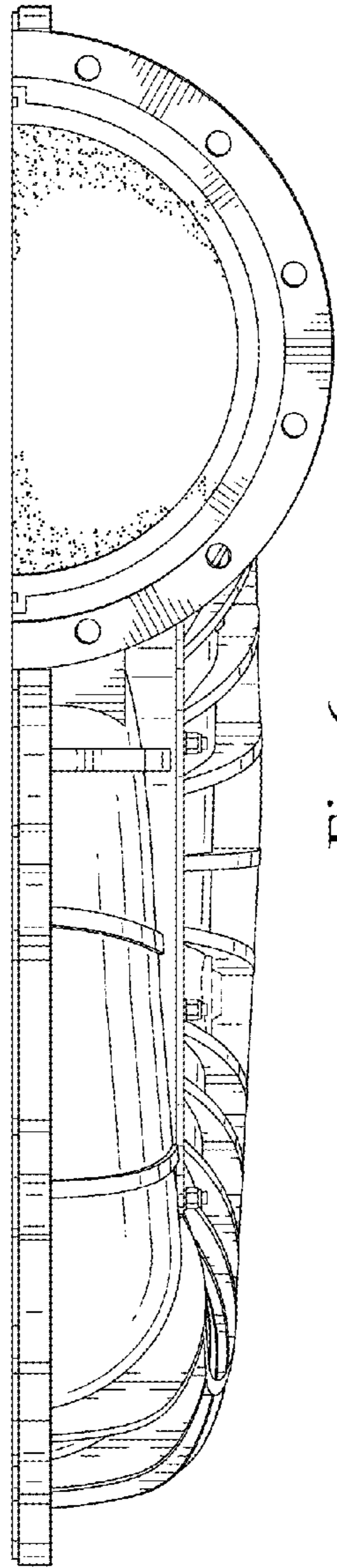

Fig. 6

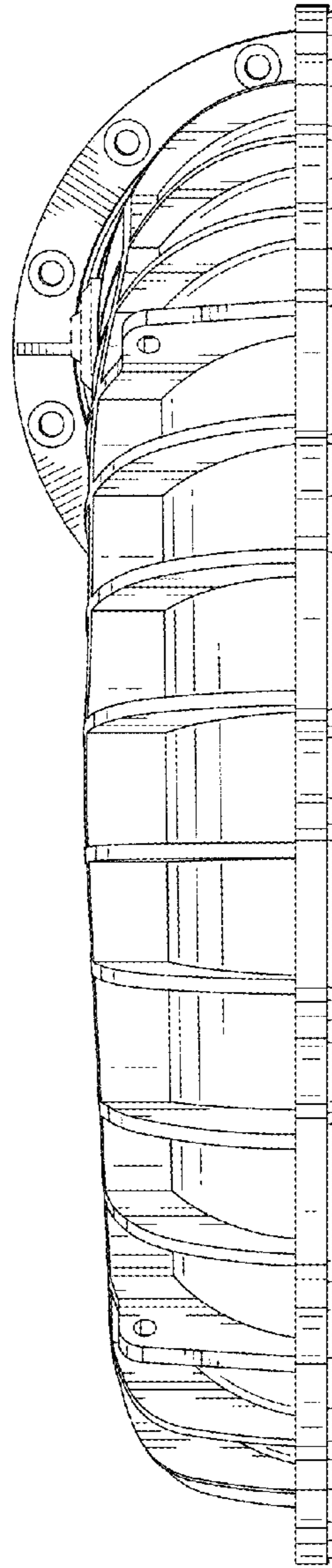

Fig. 7

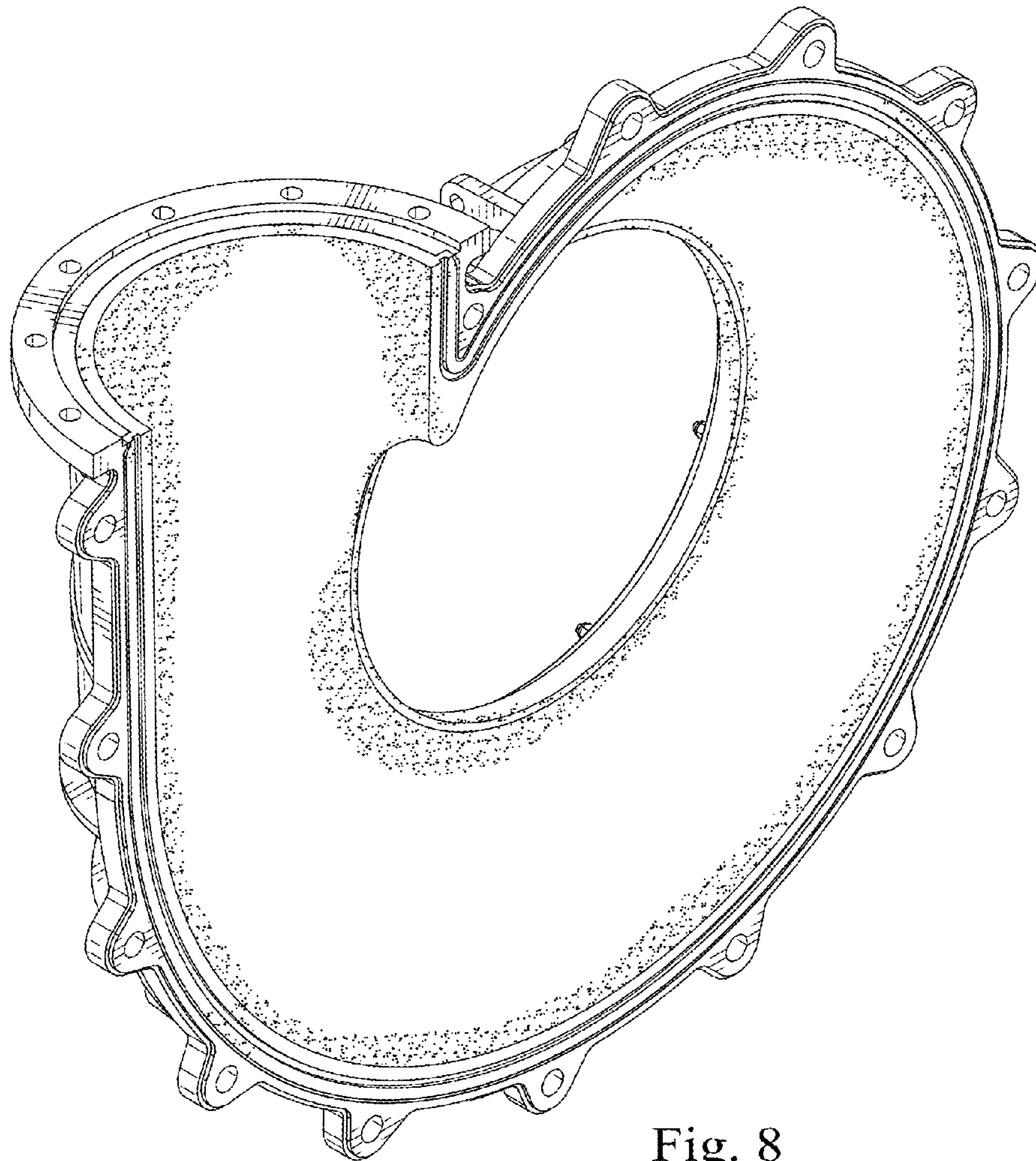

Fig. 8

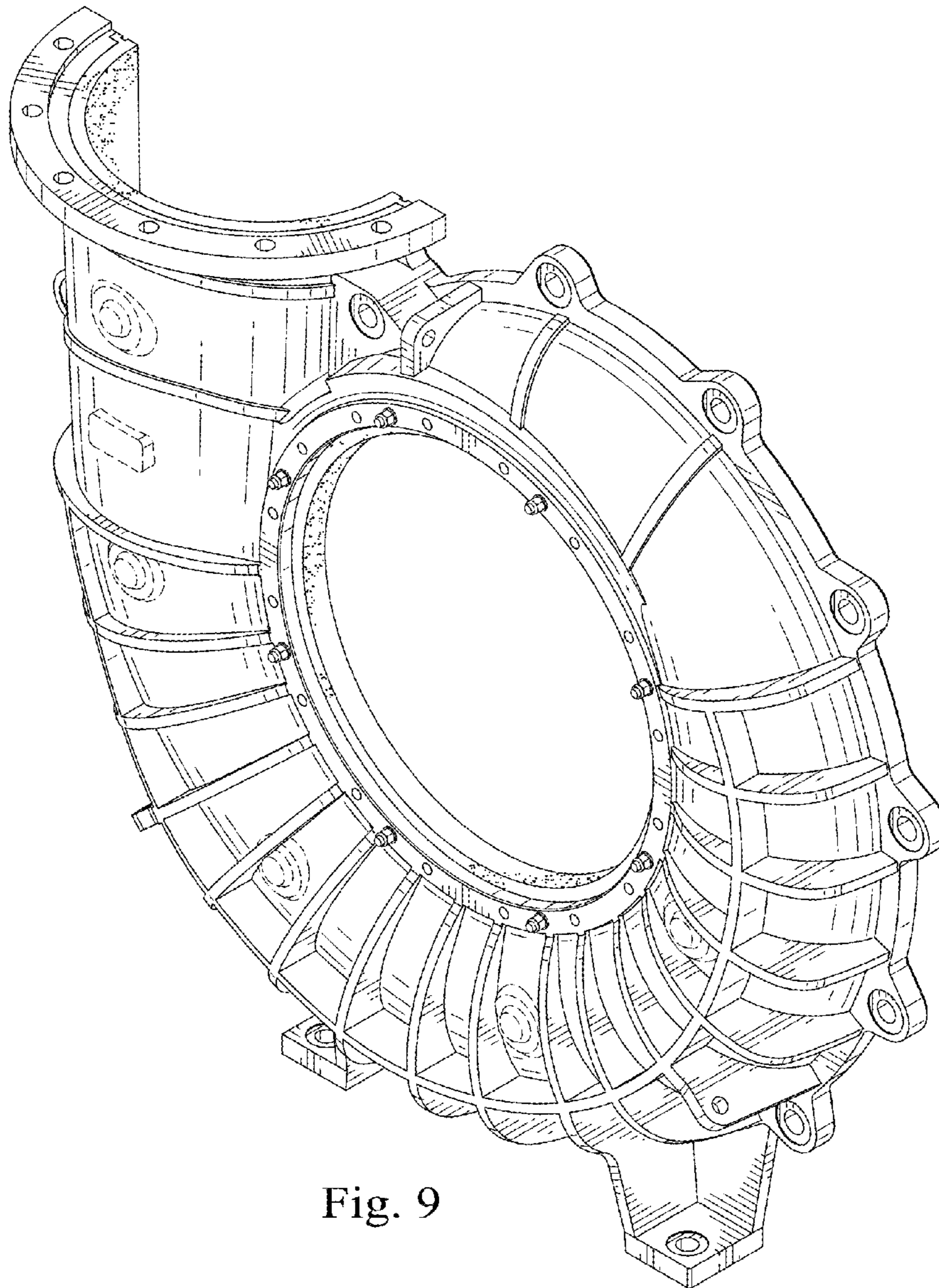

Fig. 9

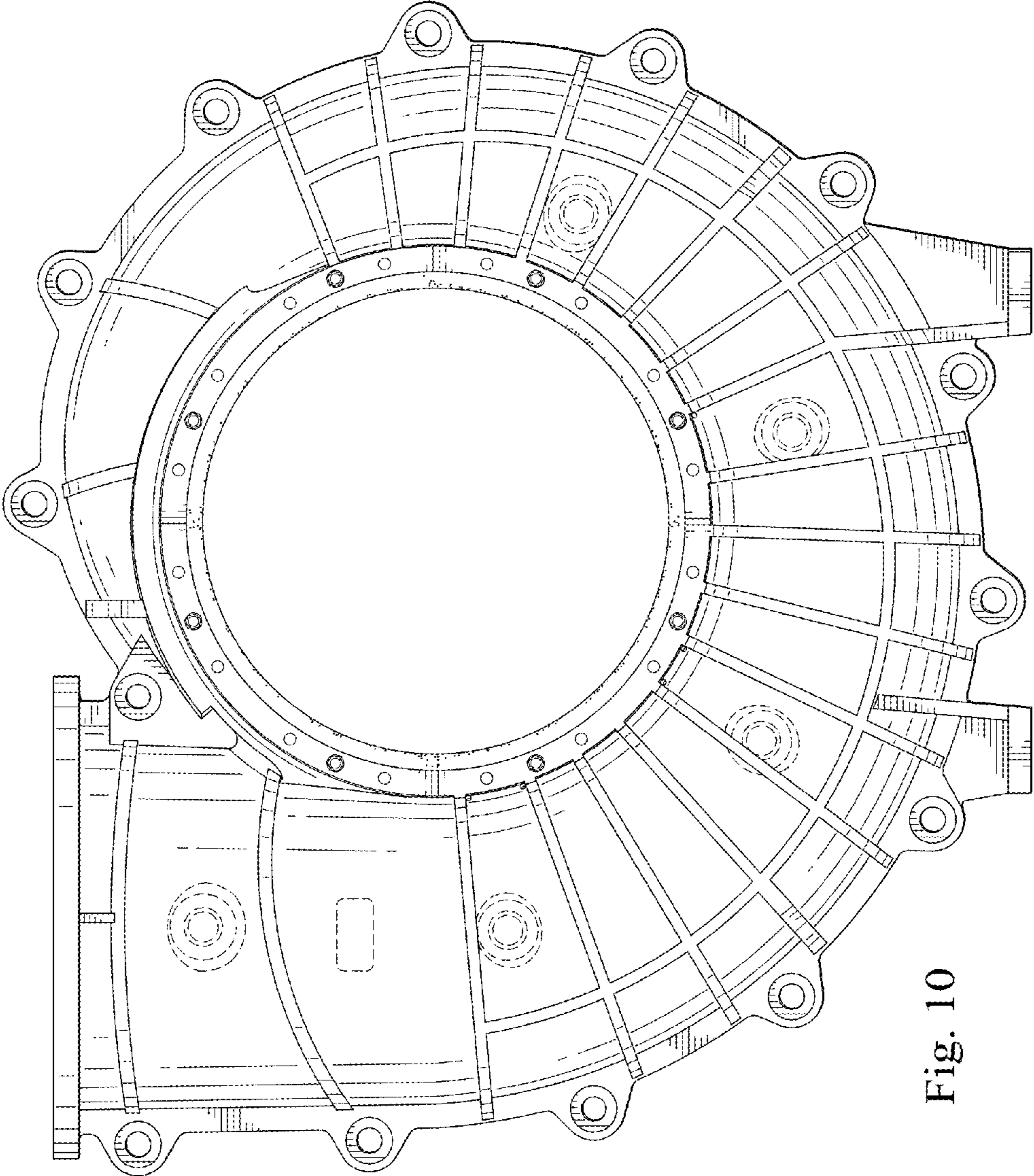

Fig. 10

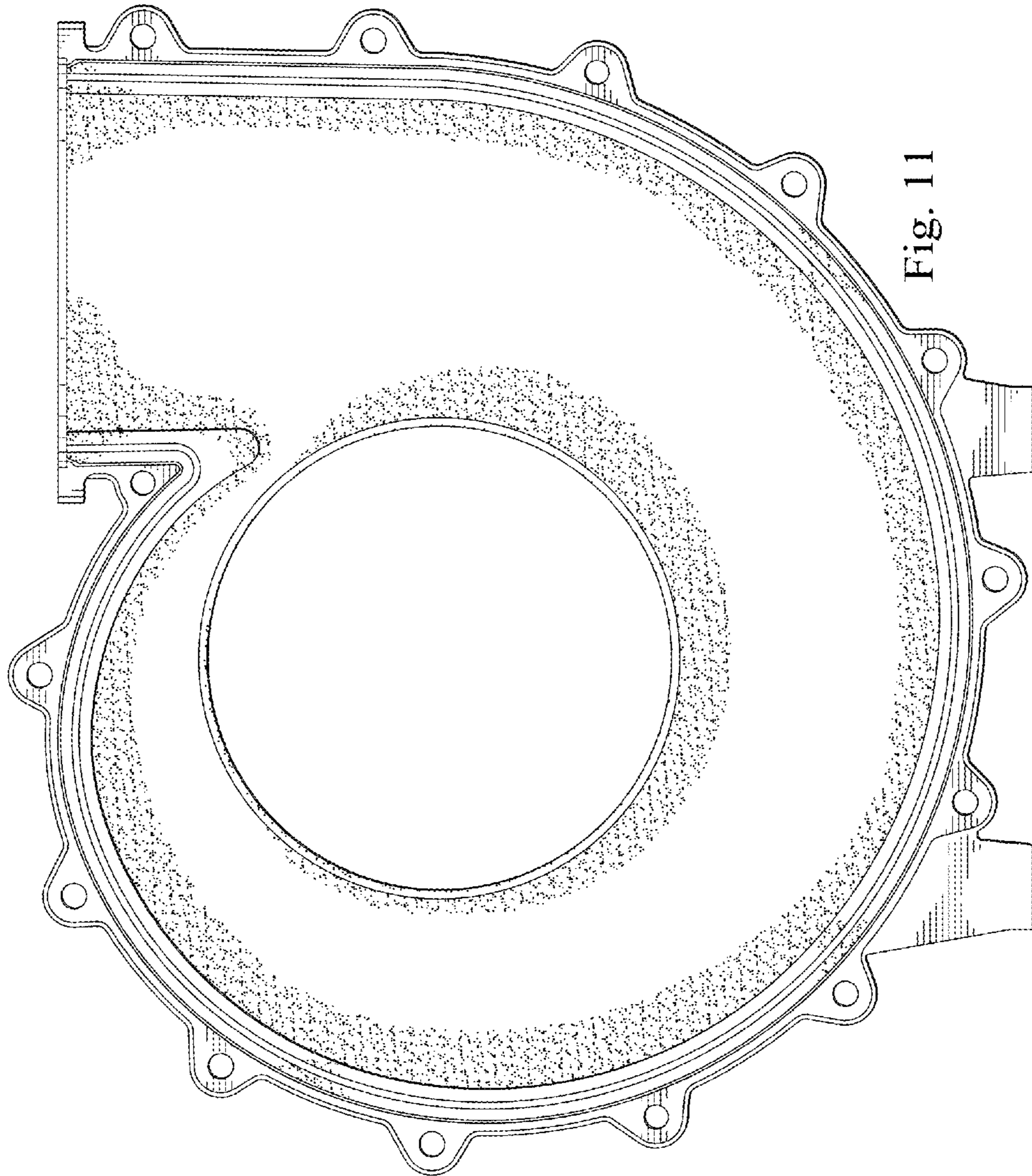

Fig. 11

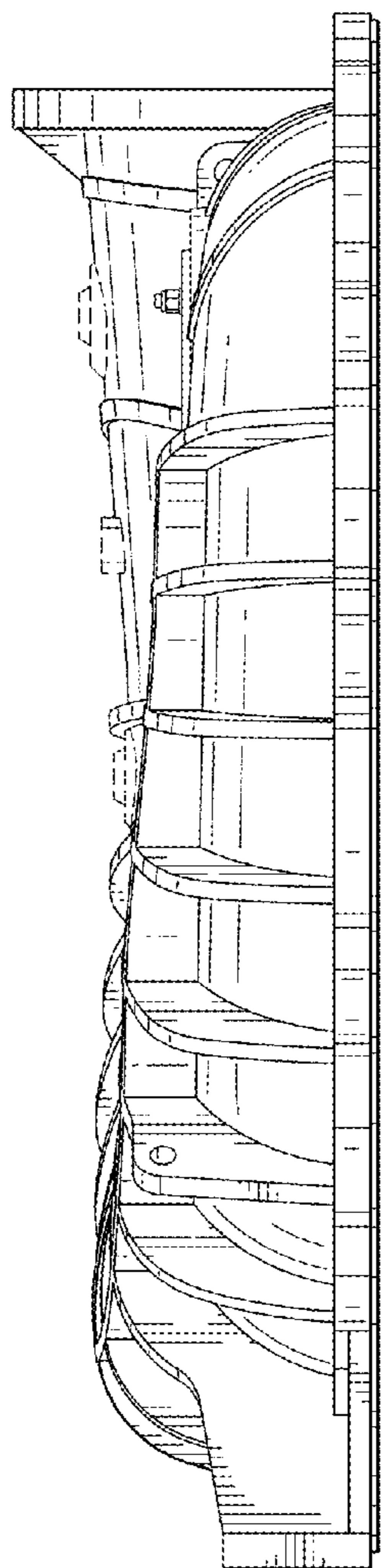

Fig. 12

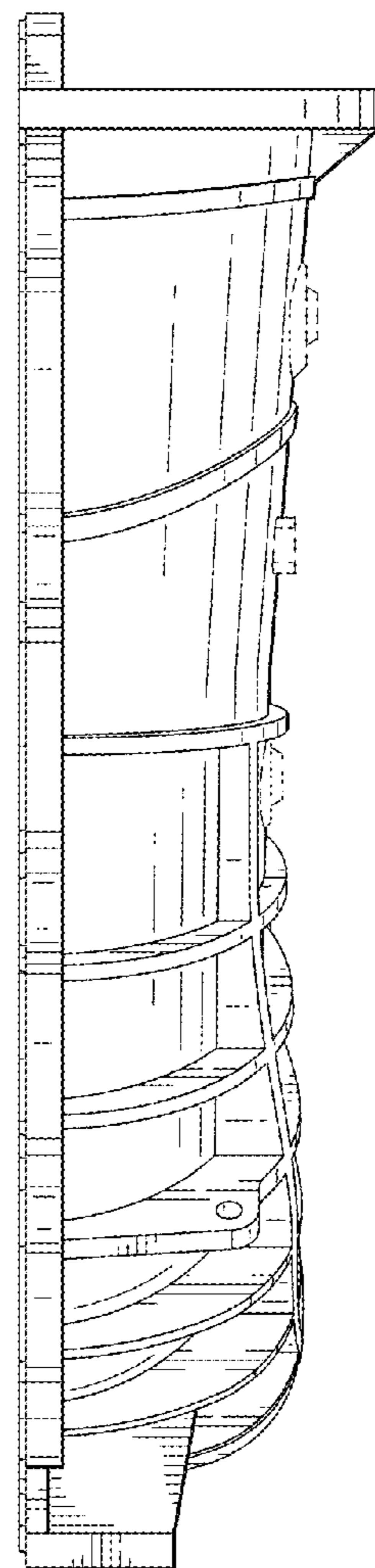

Fig. 13

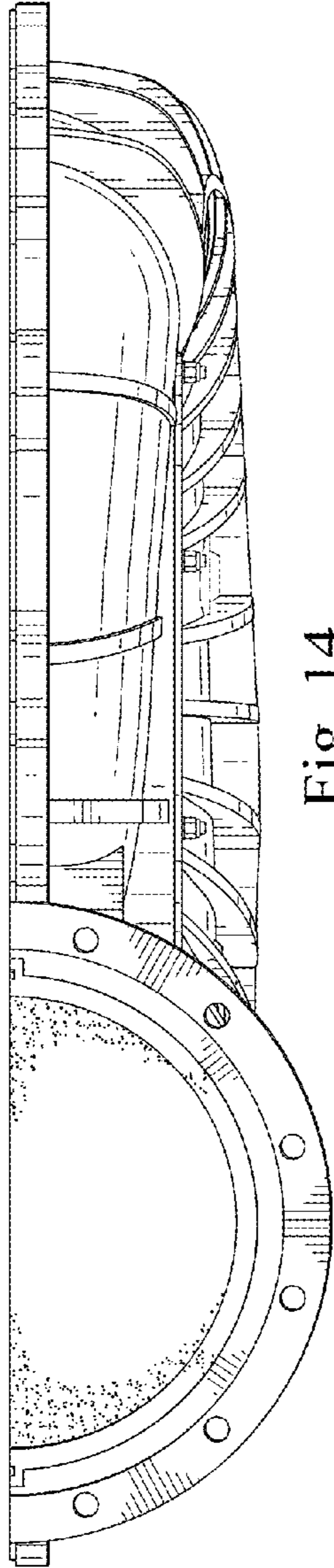

Fig. 14

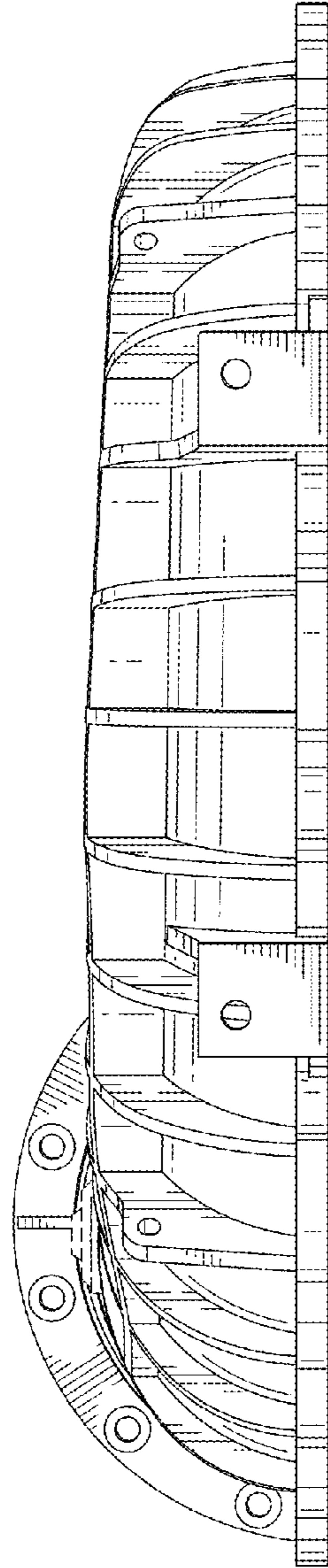

Fig. 15

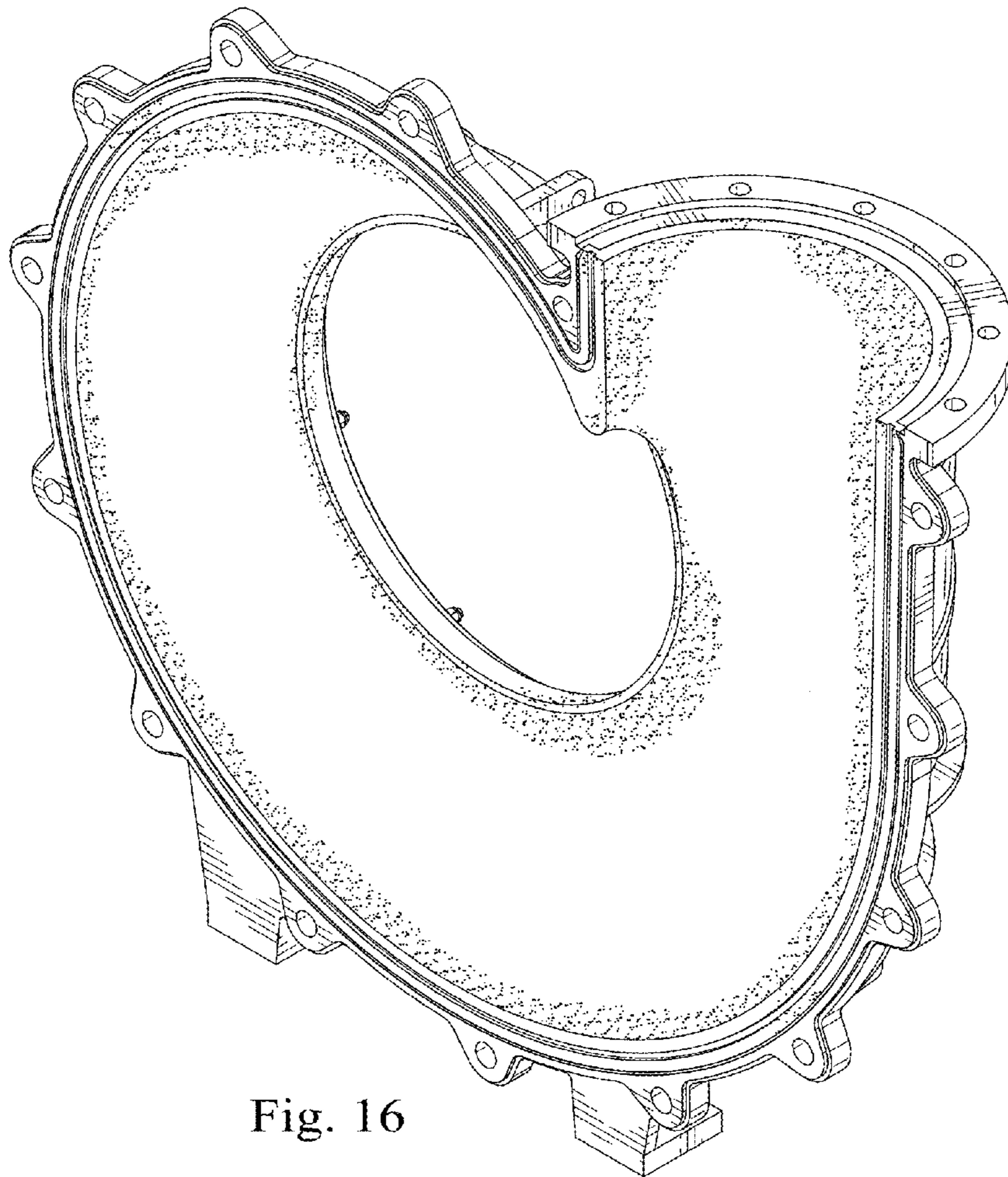

Fig. 16

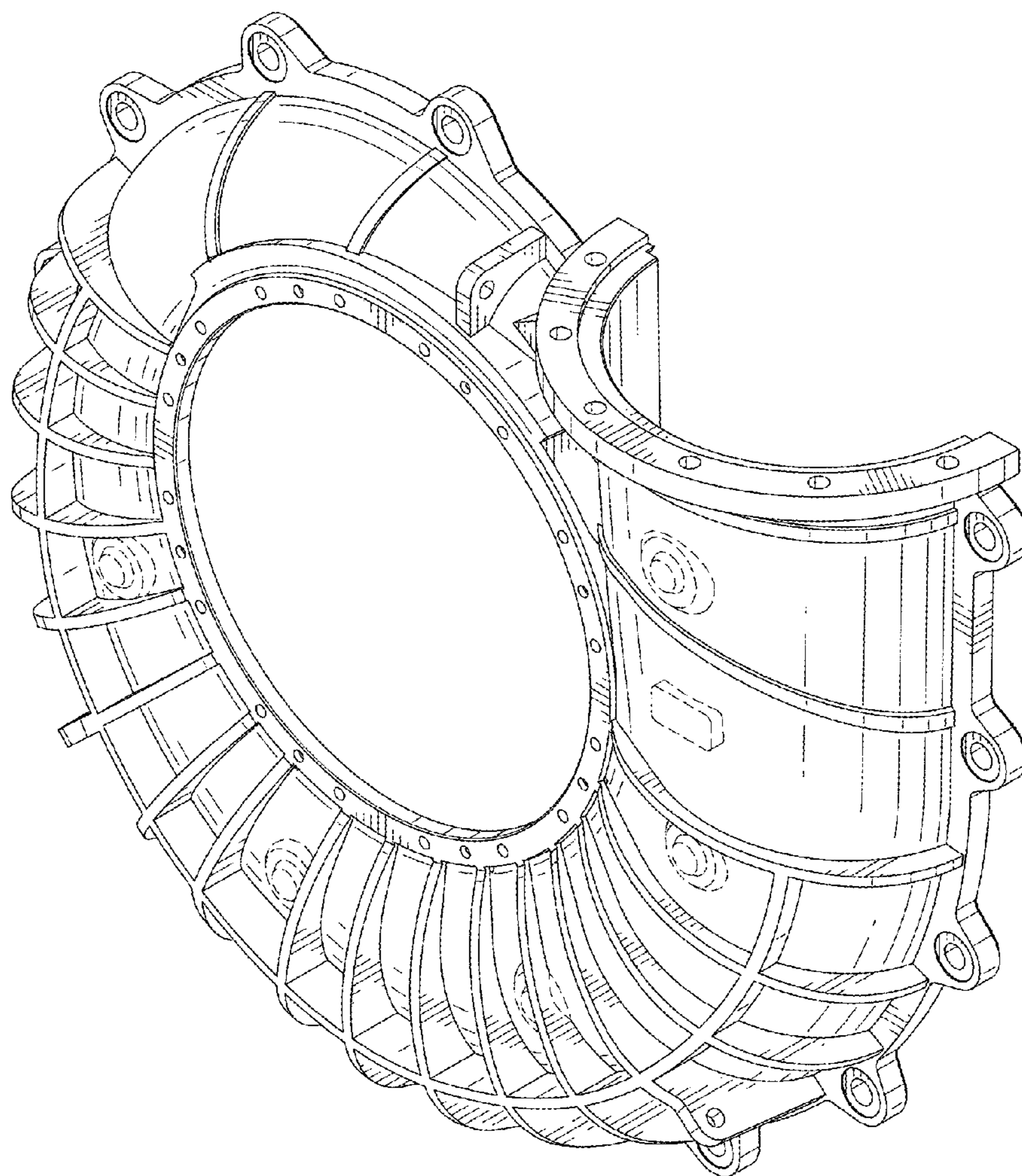

Fig. 17

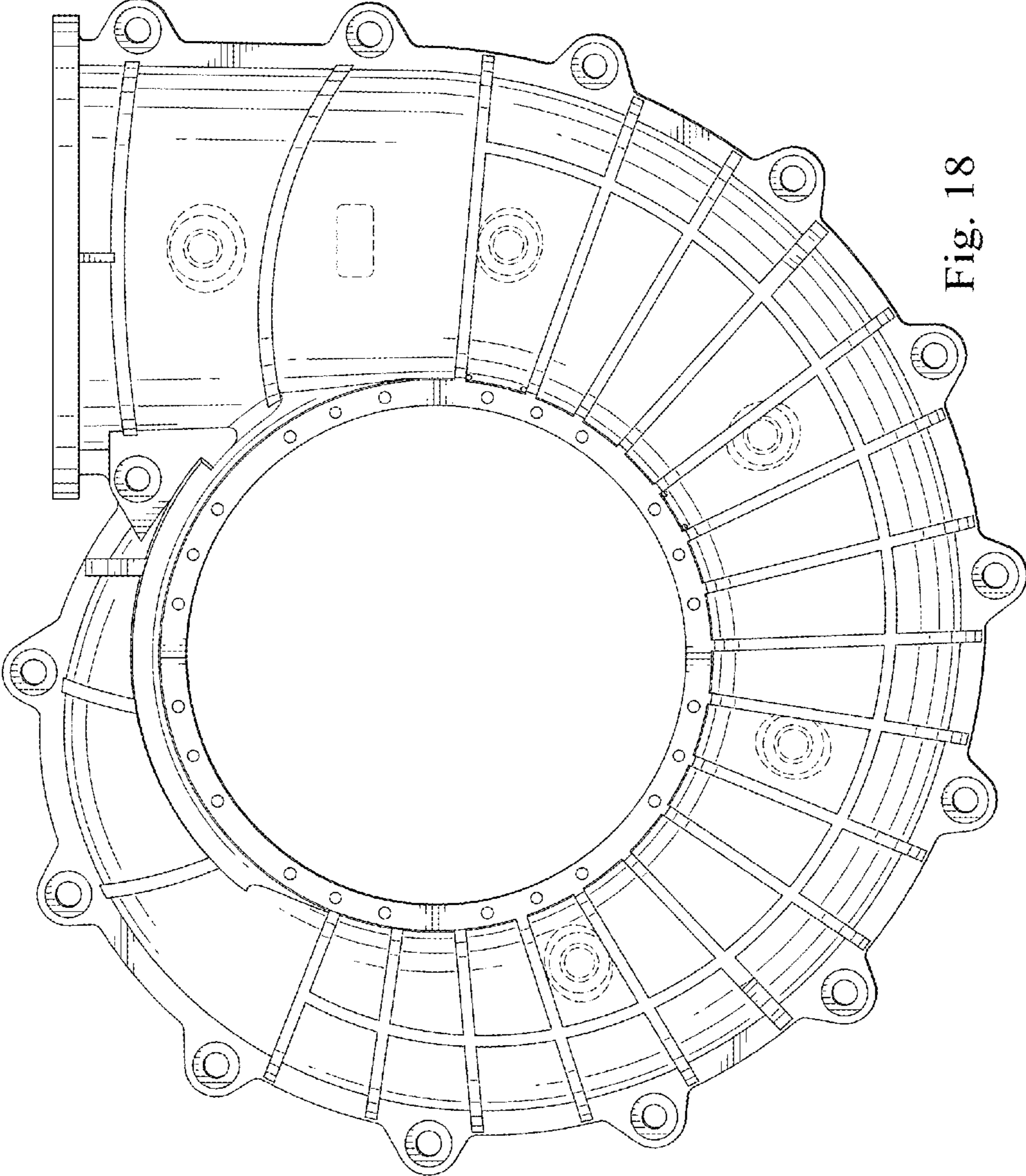

Fig. 18

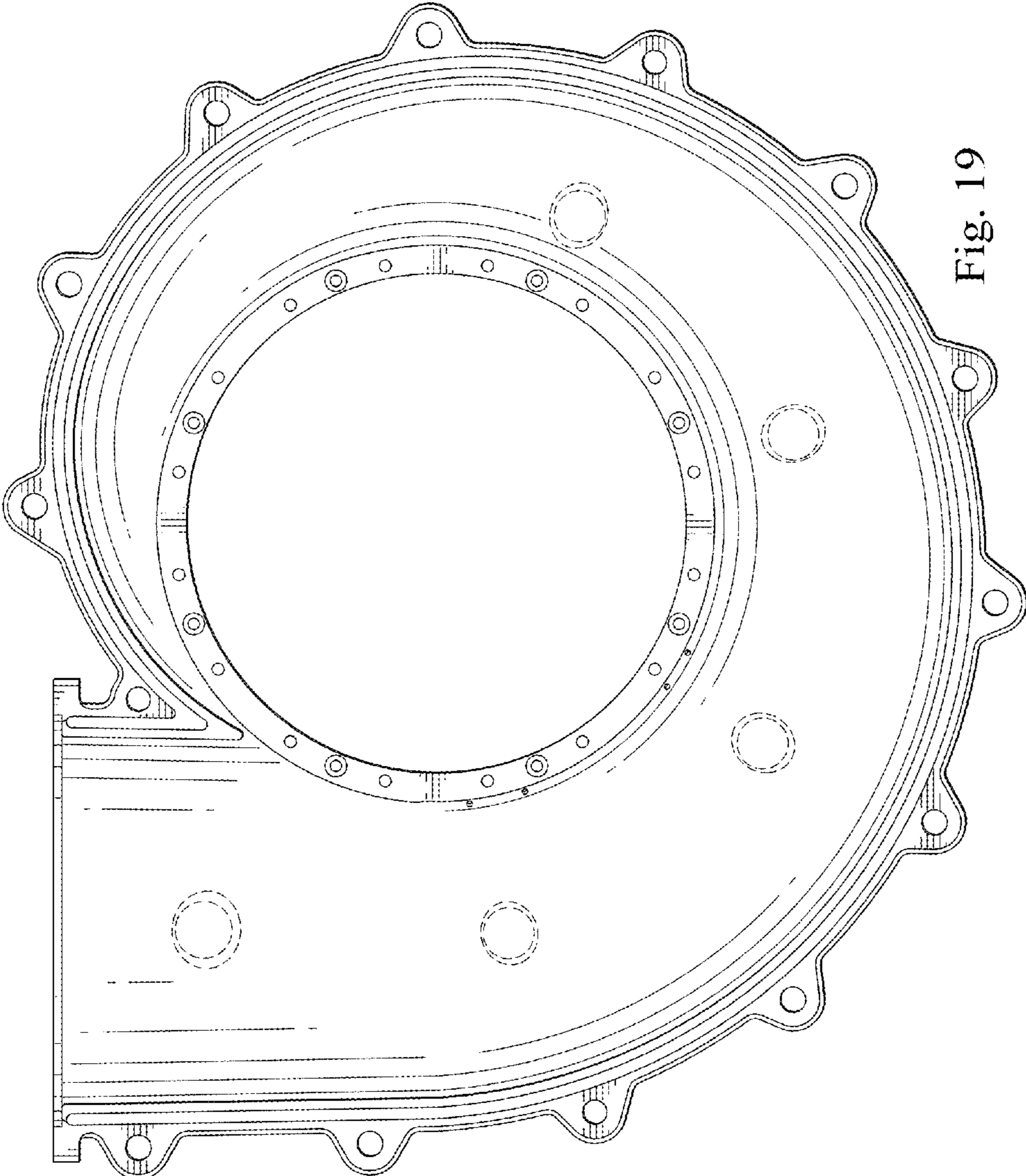

Fig. 19

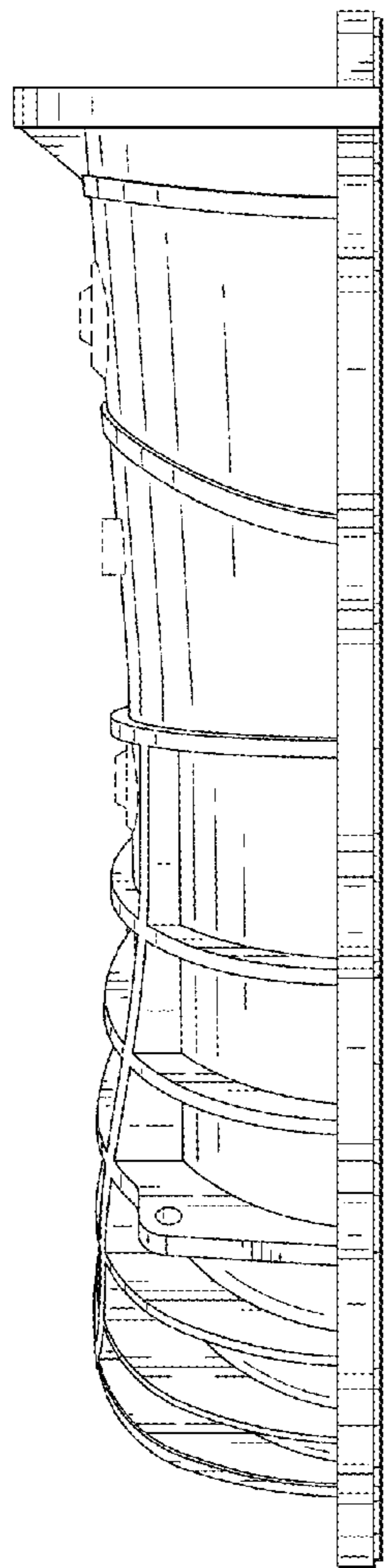

Fig. 20

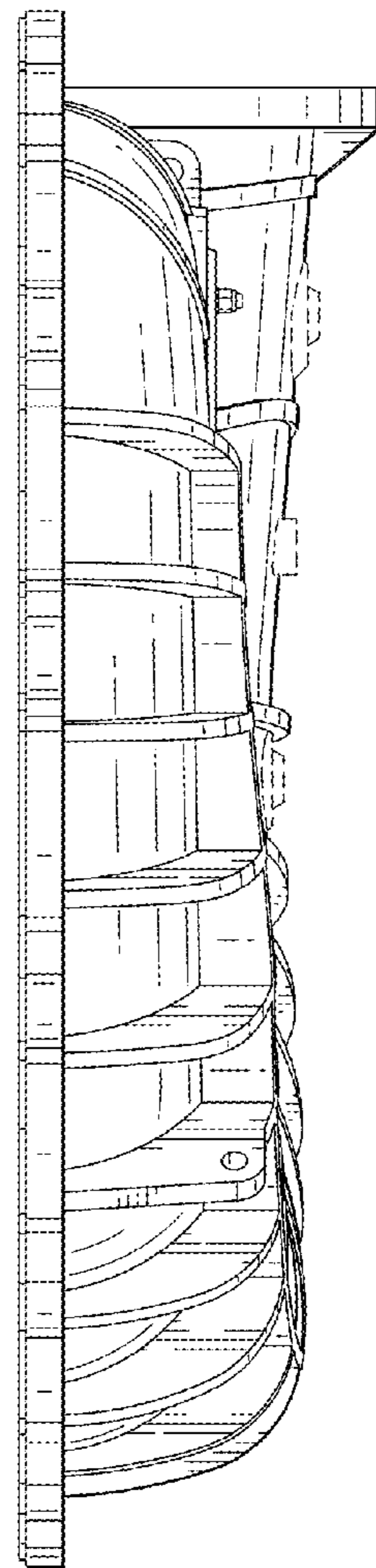

Fig. 21

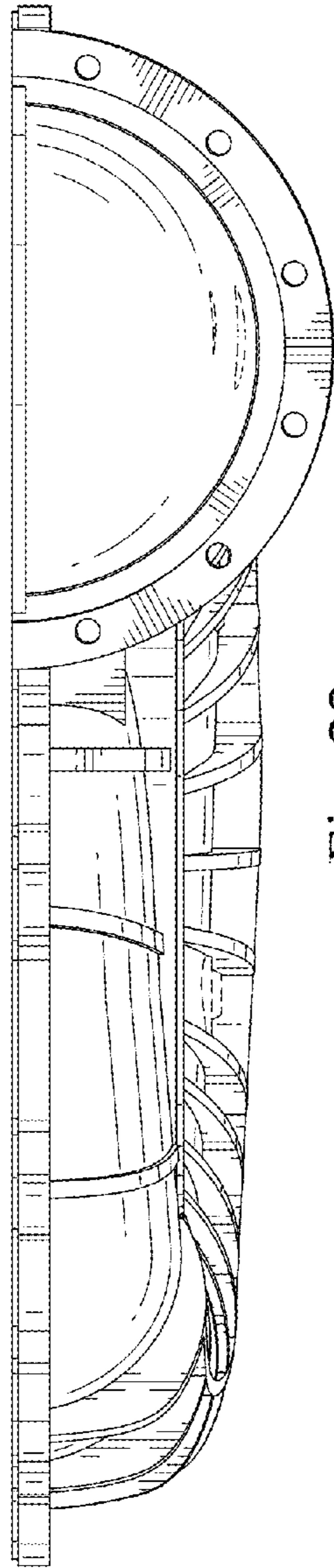

Fig. 22

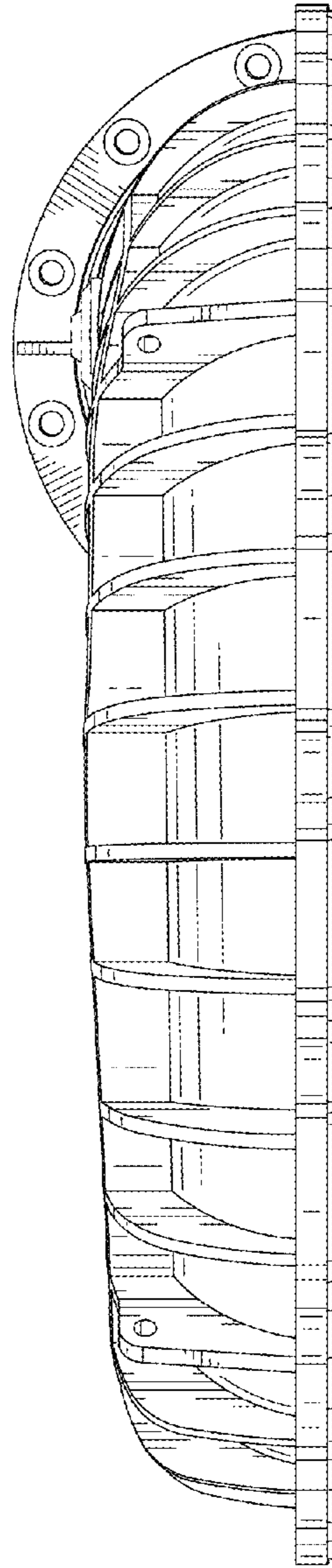

Fig. 23

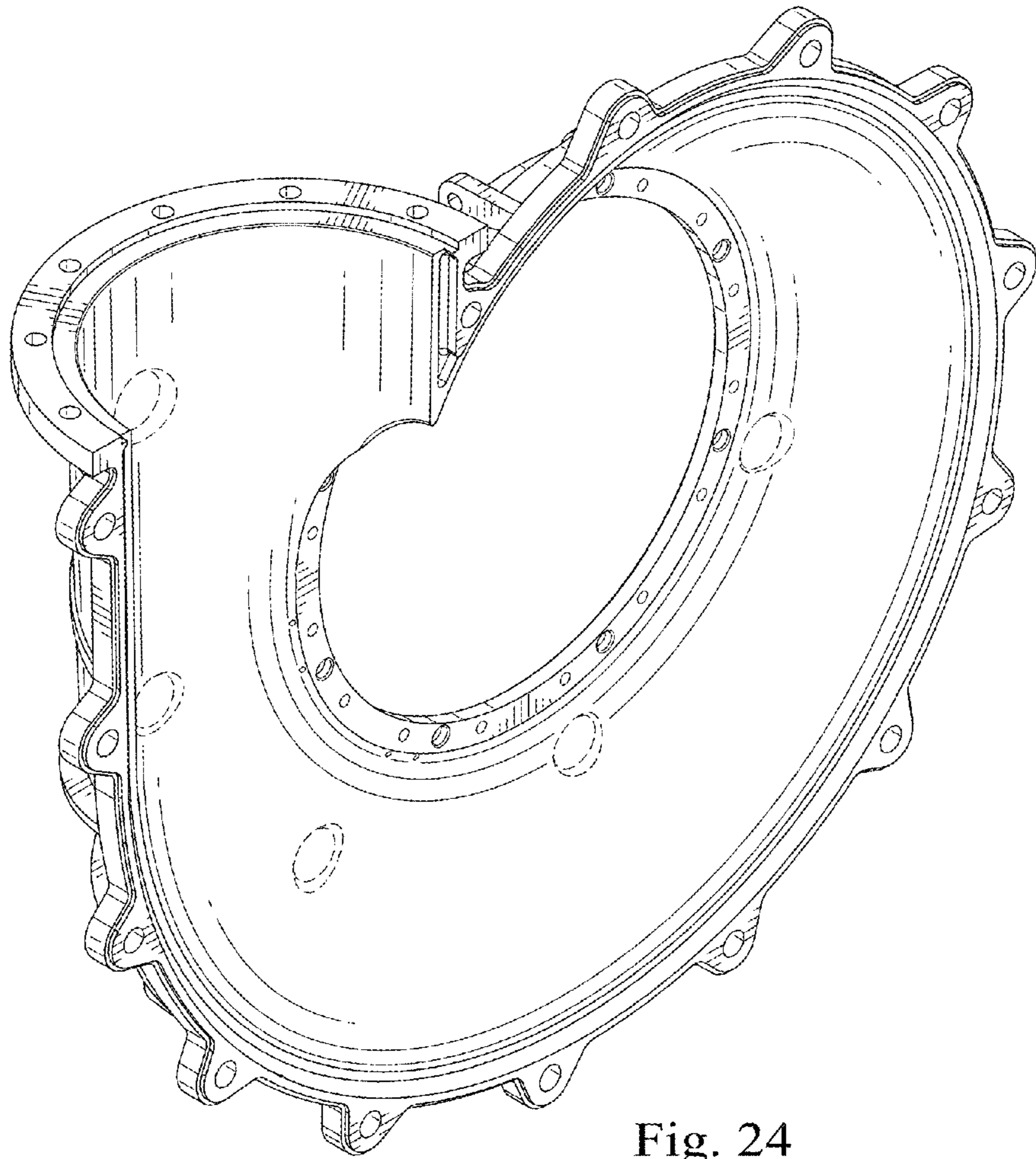

Fig. 24

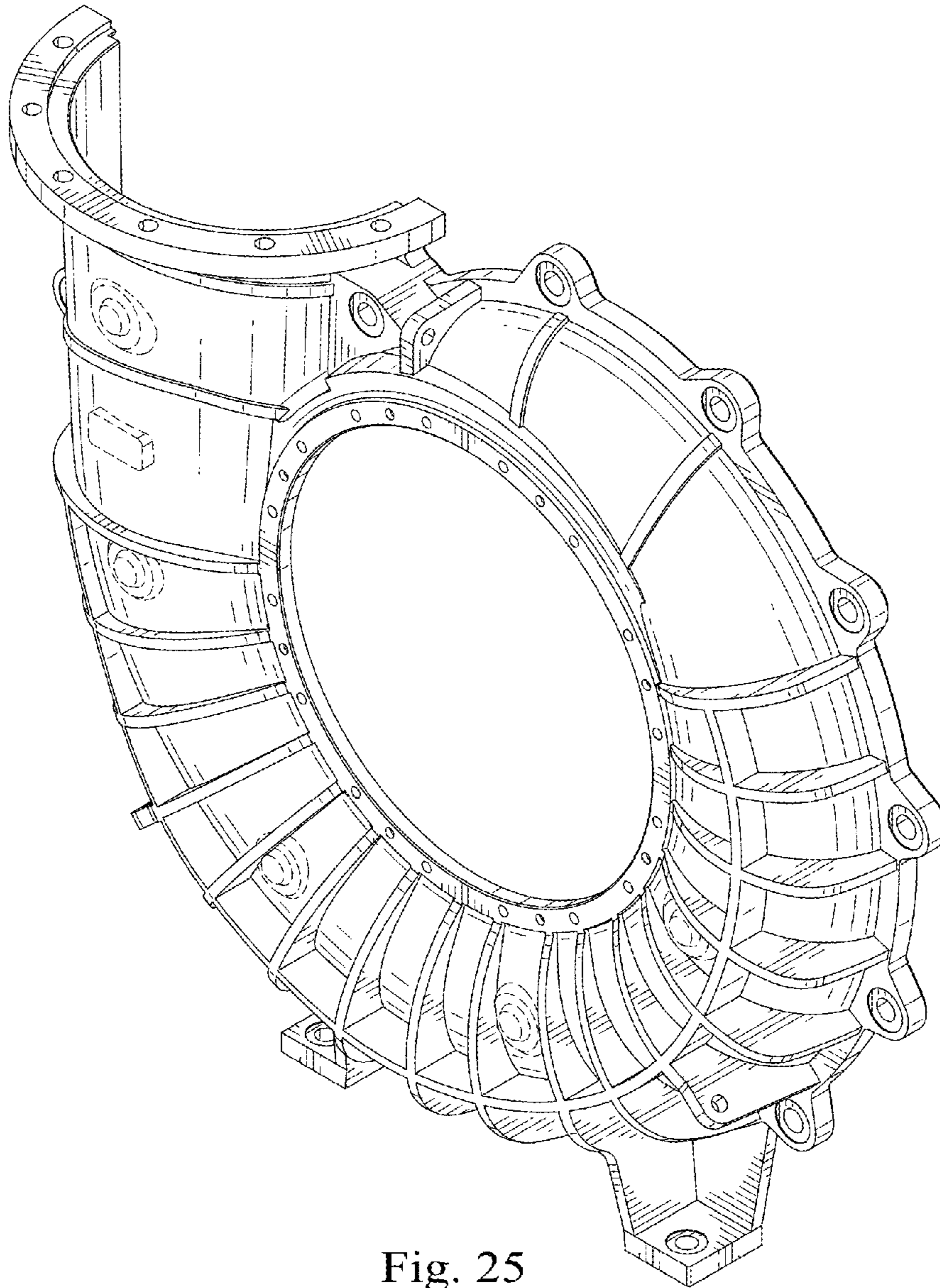

Fig. 25

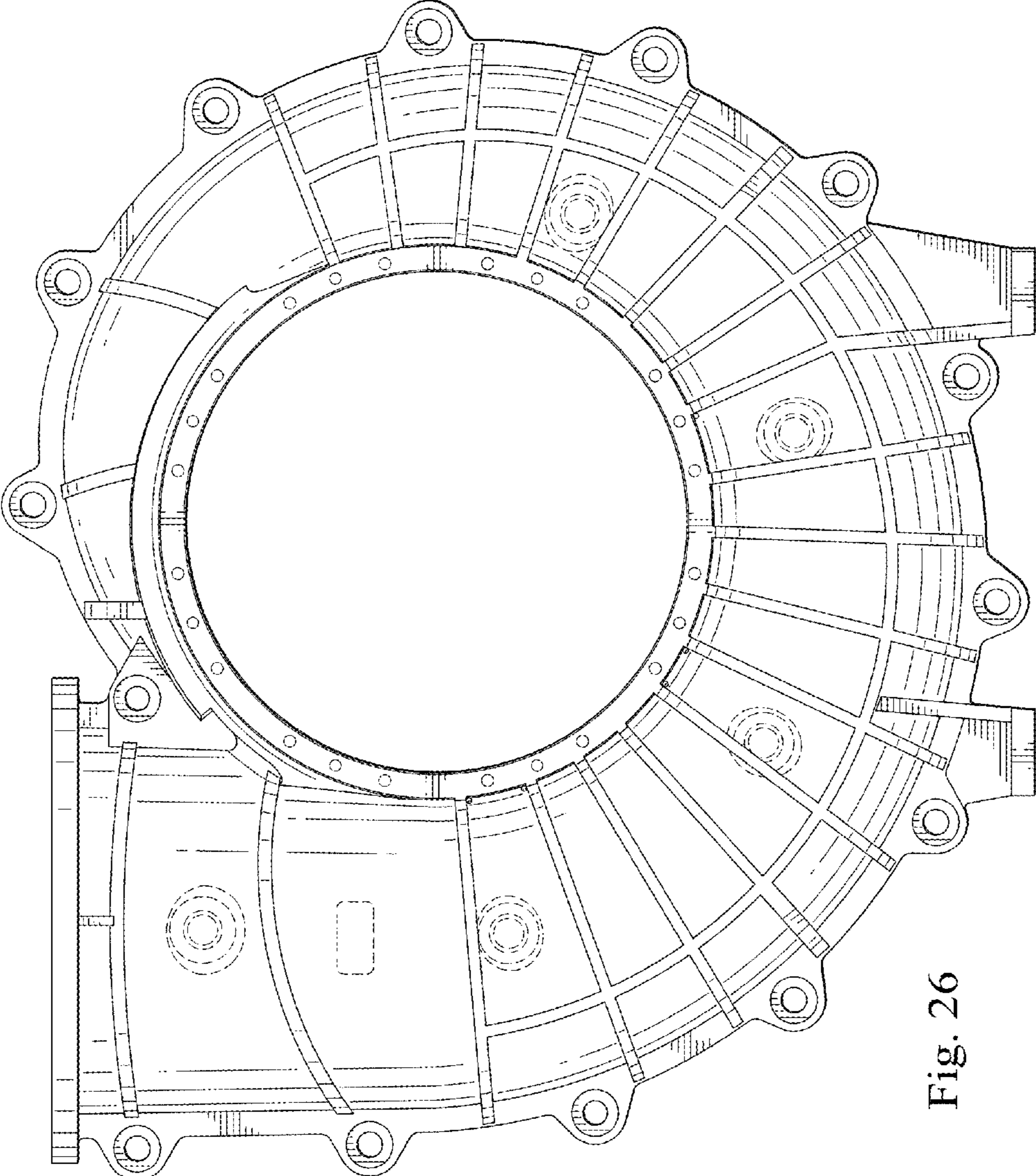

Fig. 26

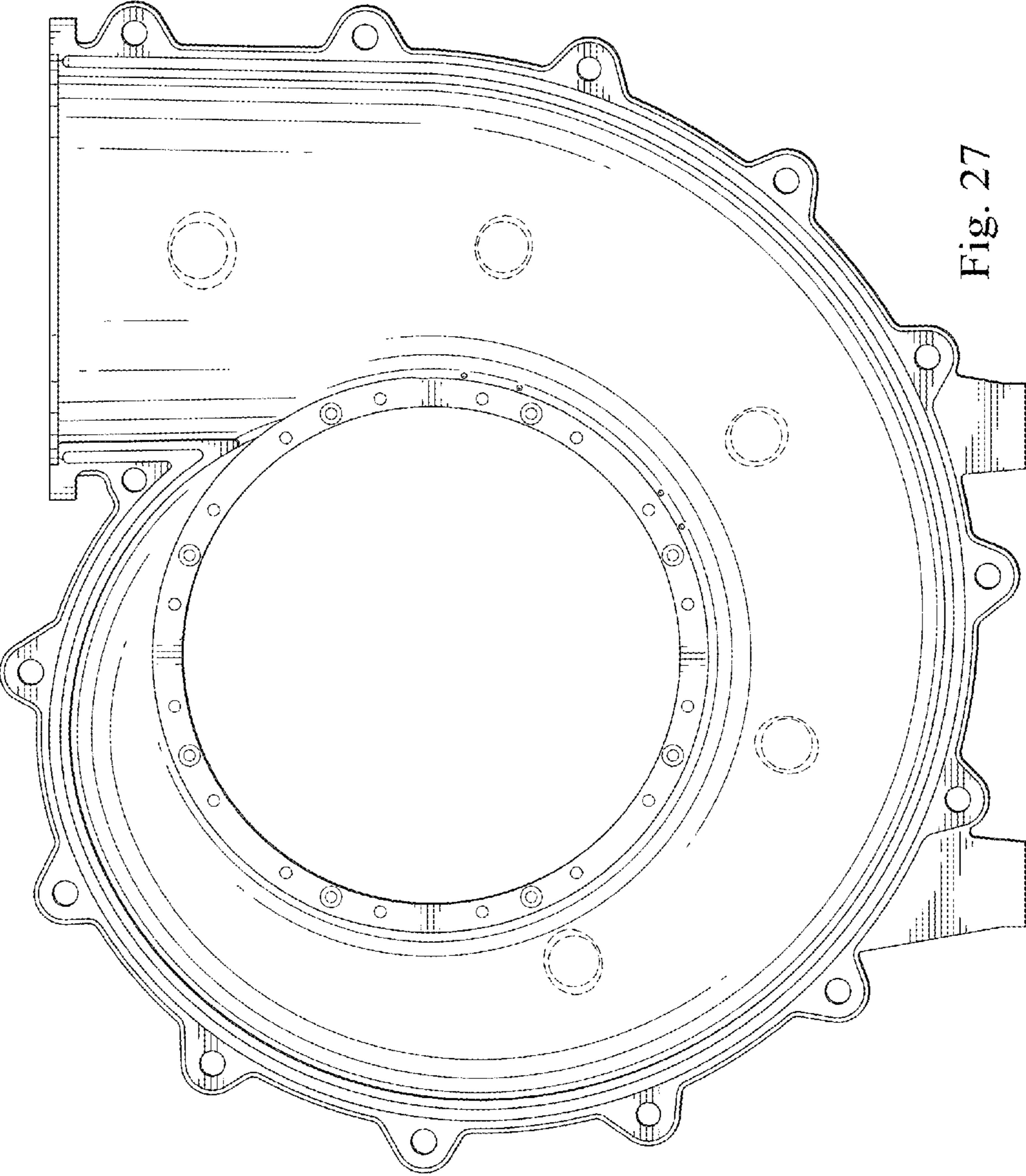

Fig. 27

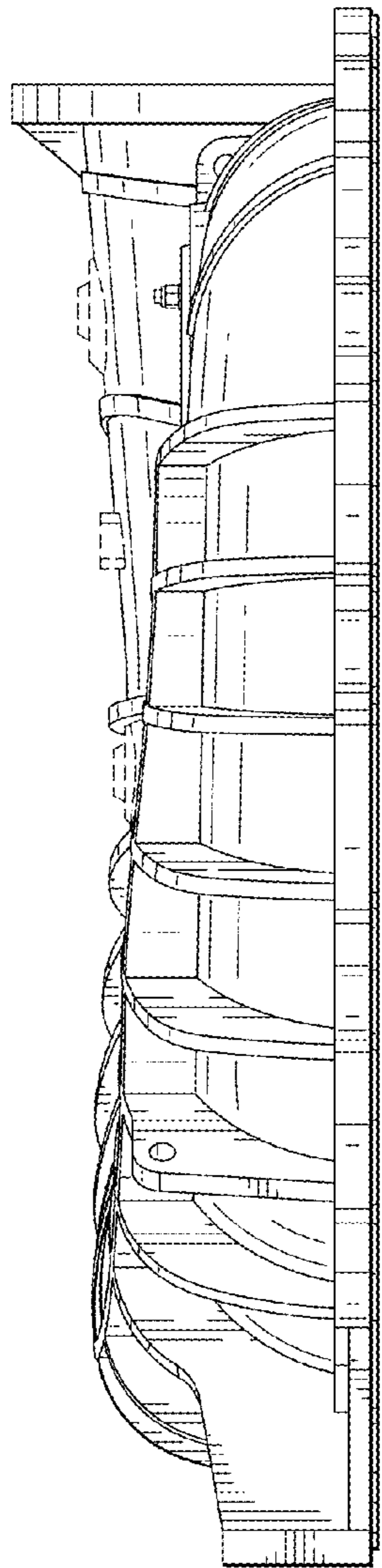

Fig. 28

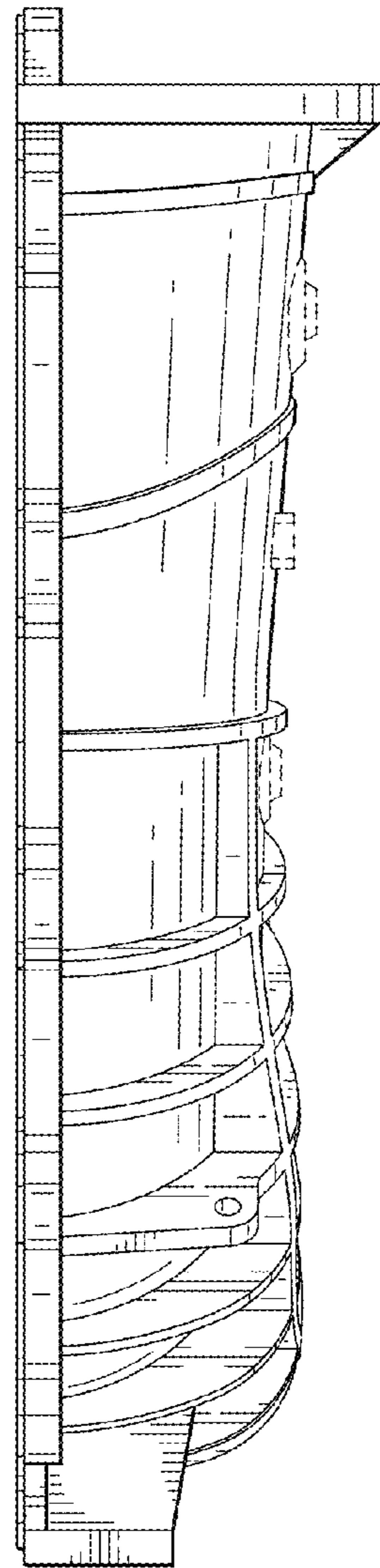

Fig. 29

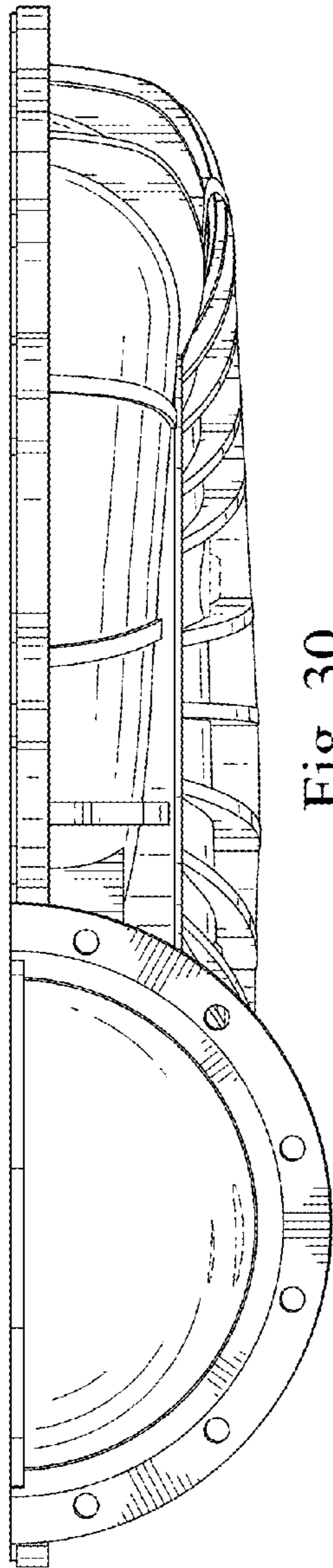

Fig. 30

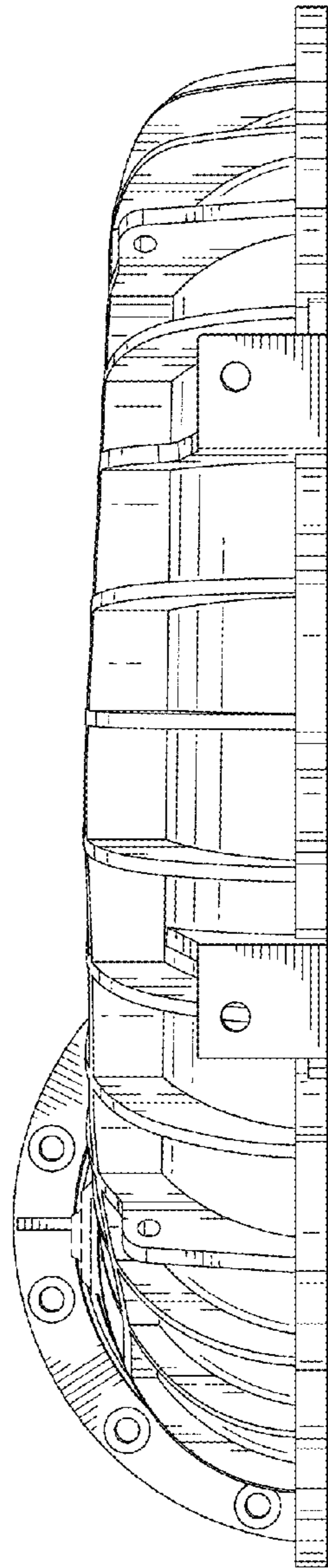

Fig. 31

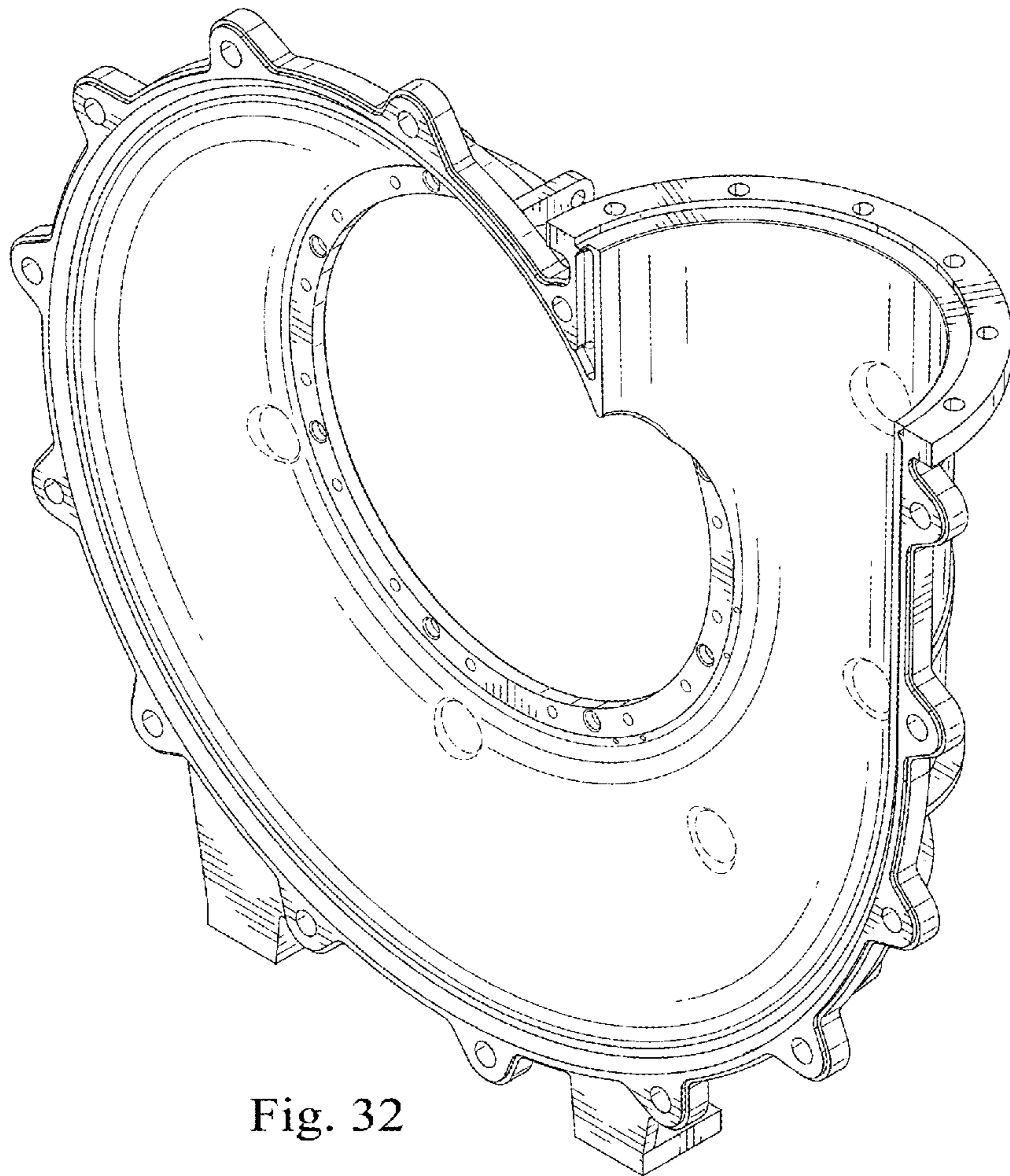

Fig. 32