

US00D767528S

(12) **United States Design Patent**
Hibi

(10) **Patent No.:** **US D767,528 S**

(45) **Date of Patent:** **** Sep. 27, 2016**

(54) **AMPLIFIER**

(71) Applicant: **Digital Acoustic Corporation**, Osaka (JP)

(72) Inventor: **Shingo Hibi**, Osaka (JP)

(73) Assignee: **Onkyo Corporation**, Osaka (JP)

(**) Term: **14 Years**

(21) Appl. No.: **29/502,415**

(22) Filed: **Sep. 16, 2014**

(51) **LOC (10) Cl.** **14-03**

(52) **U.S. Cl.**
USPC **D14/188**

(58) **Field of Classification Search**
USPC D14/162, 167-169, 175, 179, 188,
D14/194-198, 217, 257, 265, 299, 496;
330/1 R, 3, 4, 250; 381/86, 120;
455/344-351
CPC B60R 11/02; B60R 11/0205; B60R
11/0217; G10K 9/22; G10K 15/04; H03F
1/26; H03F 1/3247; H03F 3/24; H03F 3/181;
H03F 3/189; H03F 3/45197; H03F 2200/03;
H03F 2200/324; H03F 2200/336; H03F
2200/543; H03F 2203/45488; H03G 3/02;
H03G 3/20; H04R 1/028; H04R 3/00;
H04R 3/12; H04R 2420/07; H04R 2499/13
See application file for complete search history.

(56) **References Cited**

U.S. PATENT DOCUMENTS

D444,138 S * 6/2001 Ito D14/168
D444,778 S * 7/2001 Ito D14/168
D451,083 S * 11/2001 Ito D14/168
D537,435 S * 2/2007 Oikawa D14/188

D576,147 S * 9/2008 Natori D14/188
D578,998 S * 10/2008 Natori D14/188
D606,561 S * 12/2009 Tsuboi D14/168
D662,910 S * 7/2012 Warden D14/188
D693,369 S * 11/2013 Moon D14/496

* cited by examiner

Primary Examiner — Keli L Hill

(74) *Attorney, Agent, or Firm* — Renner, Otto, Boisselle & Sklar, LLP

(57) **CLAIM**

The ornamental design for an amplifier, as shown and described.

DESCRIPTION

FIG. 1 is a perspective view of an amplifier showing my new design.

FIG. 2 is a front view thereof.

FIG. 3 is a rear view thereof.

FIG. 4 is a left side view thereof.

FIG. 5 is a right side view thereof.

FIG. 6 is a top view thereof; and,

FIG. 7 is a bottom view thereof.

The broken lines shown in the drawings represent unclaimed portions of the amplifier and form no part of the claimed design.

1 Claim, 4 Drawing Sheets

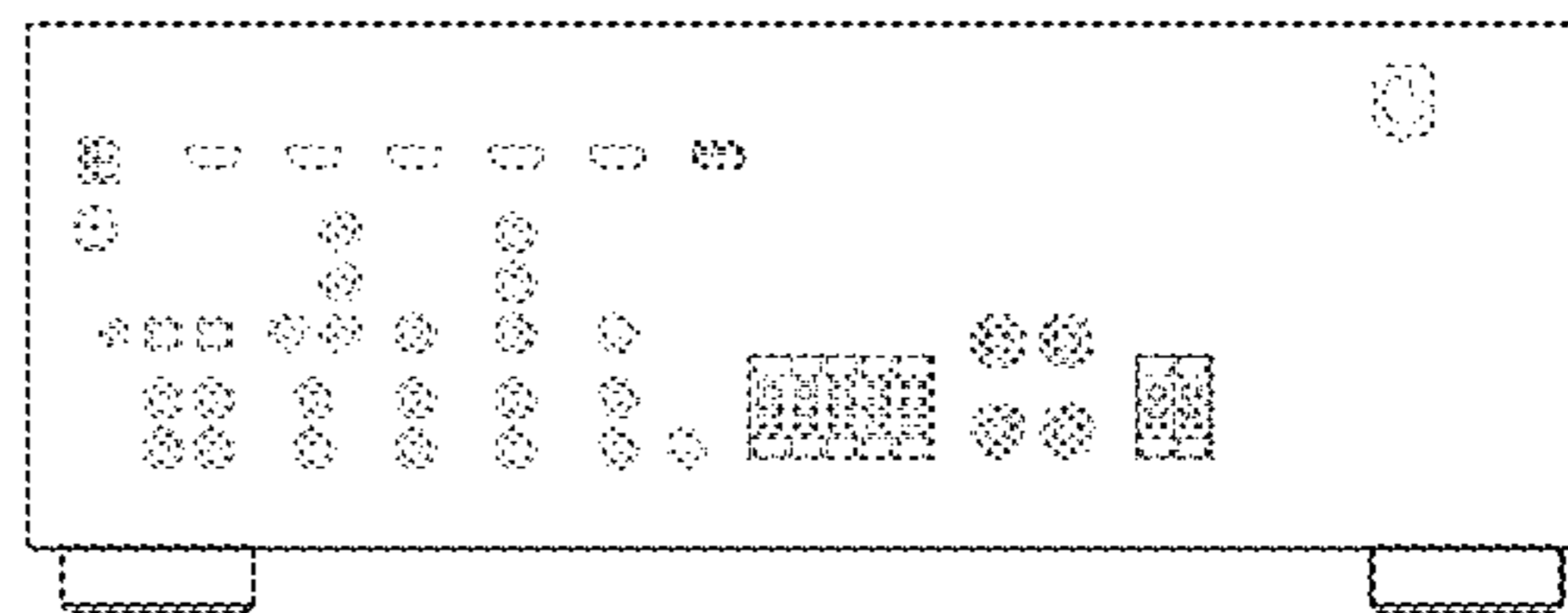
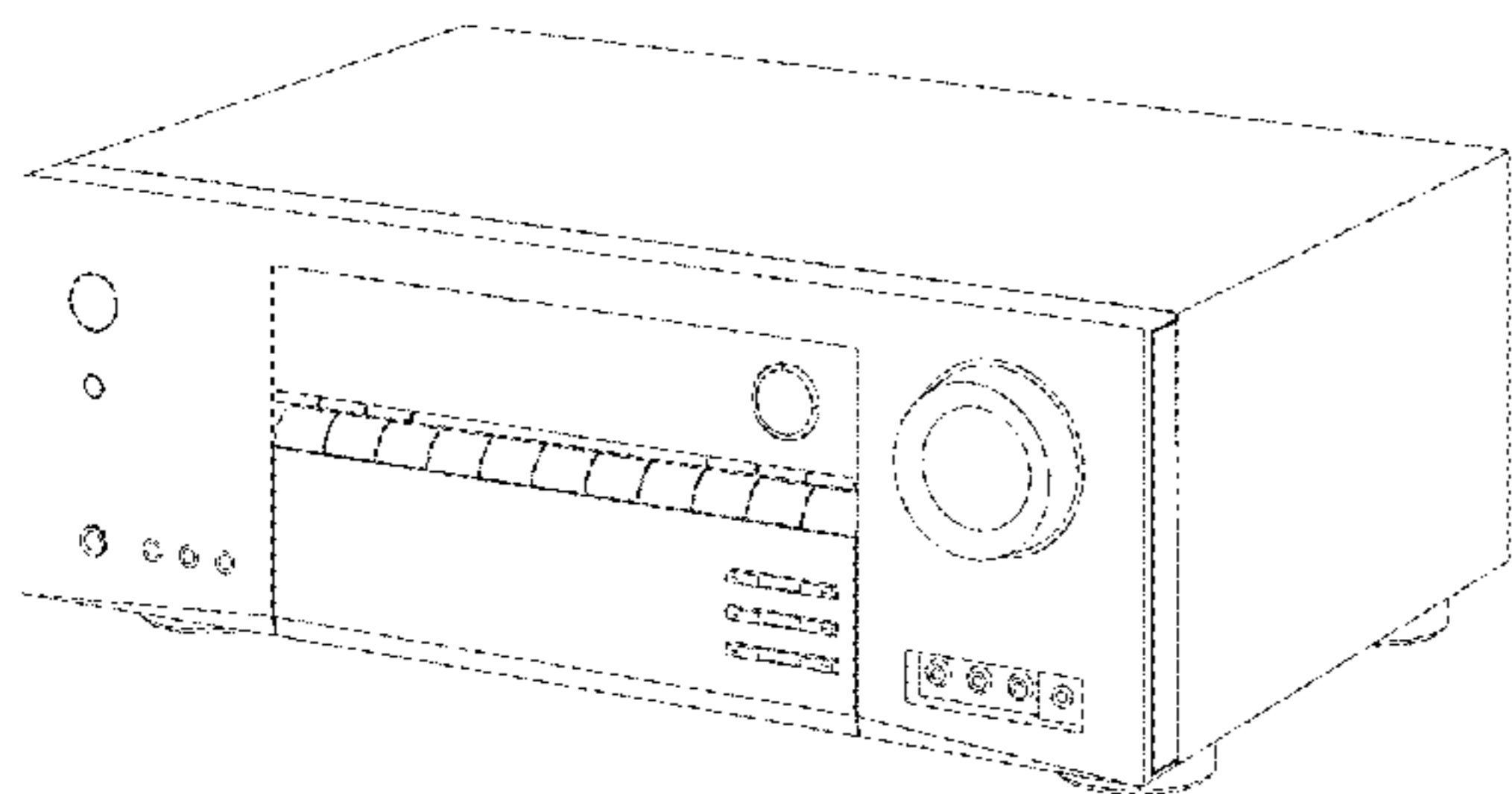

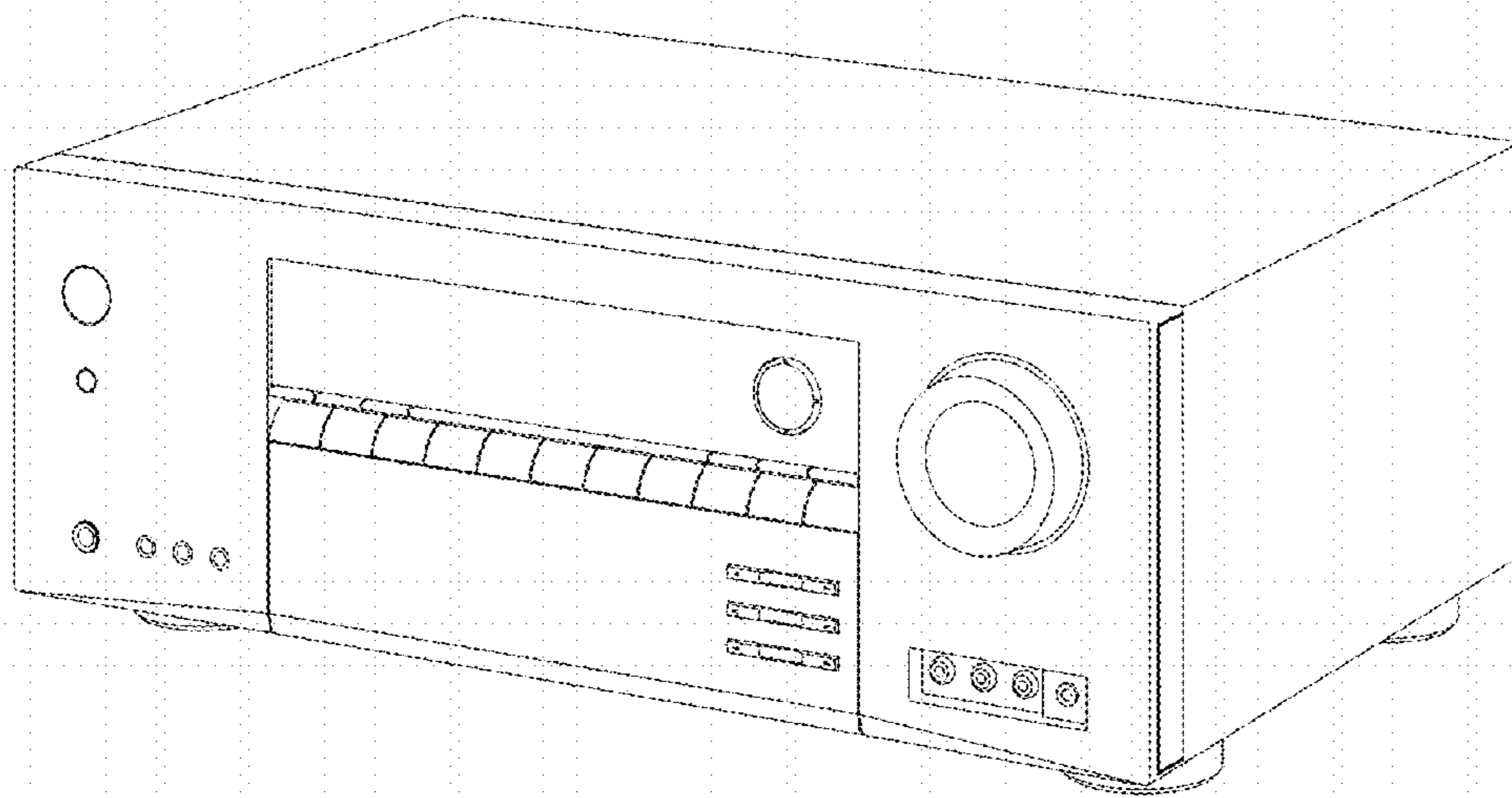

FIG. 1

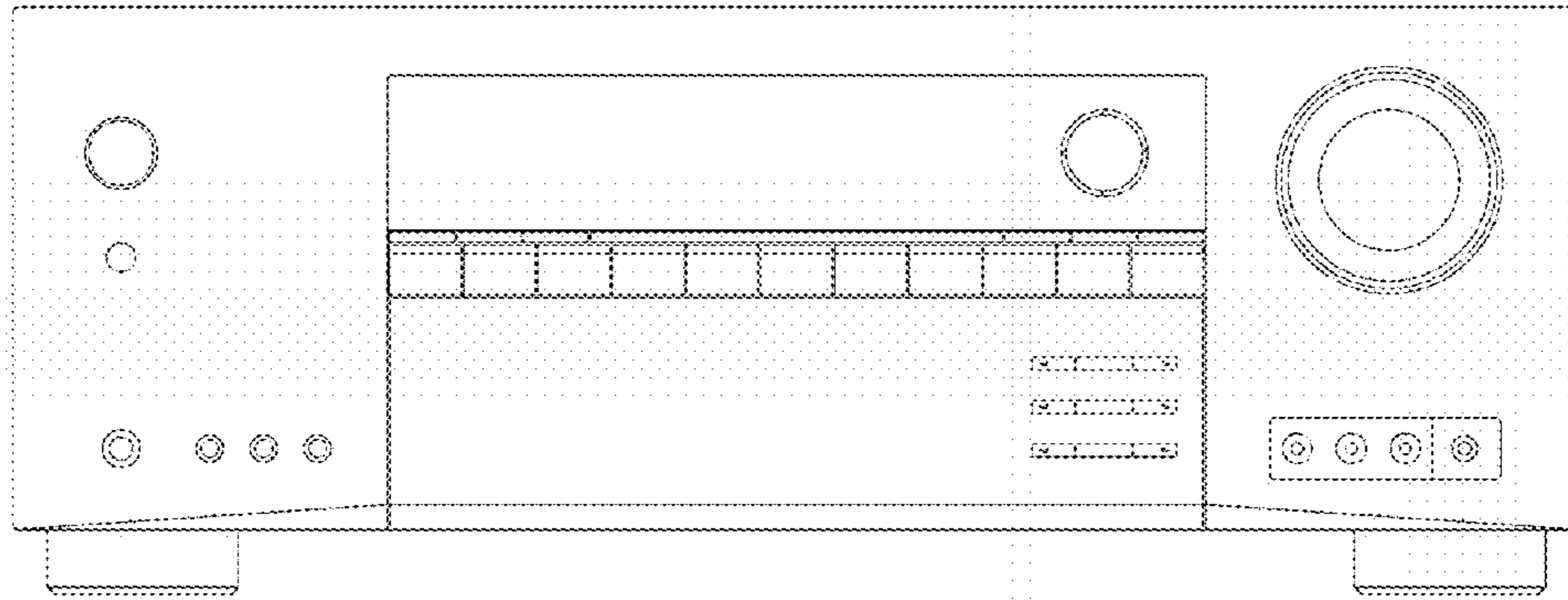

FIG. 2

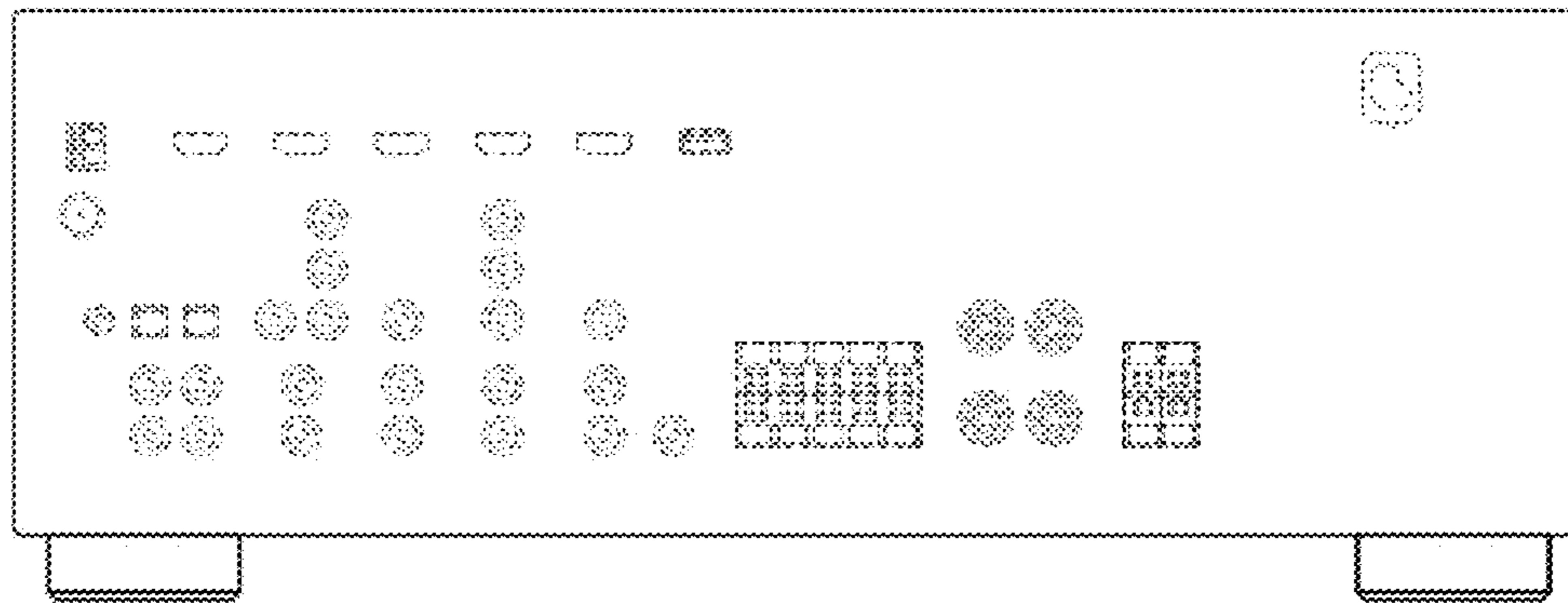

FIG. 3

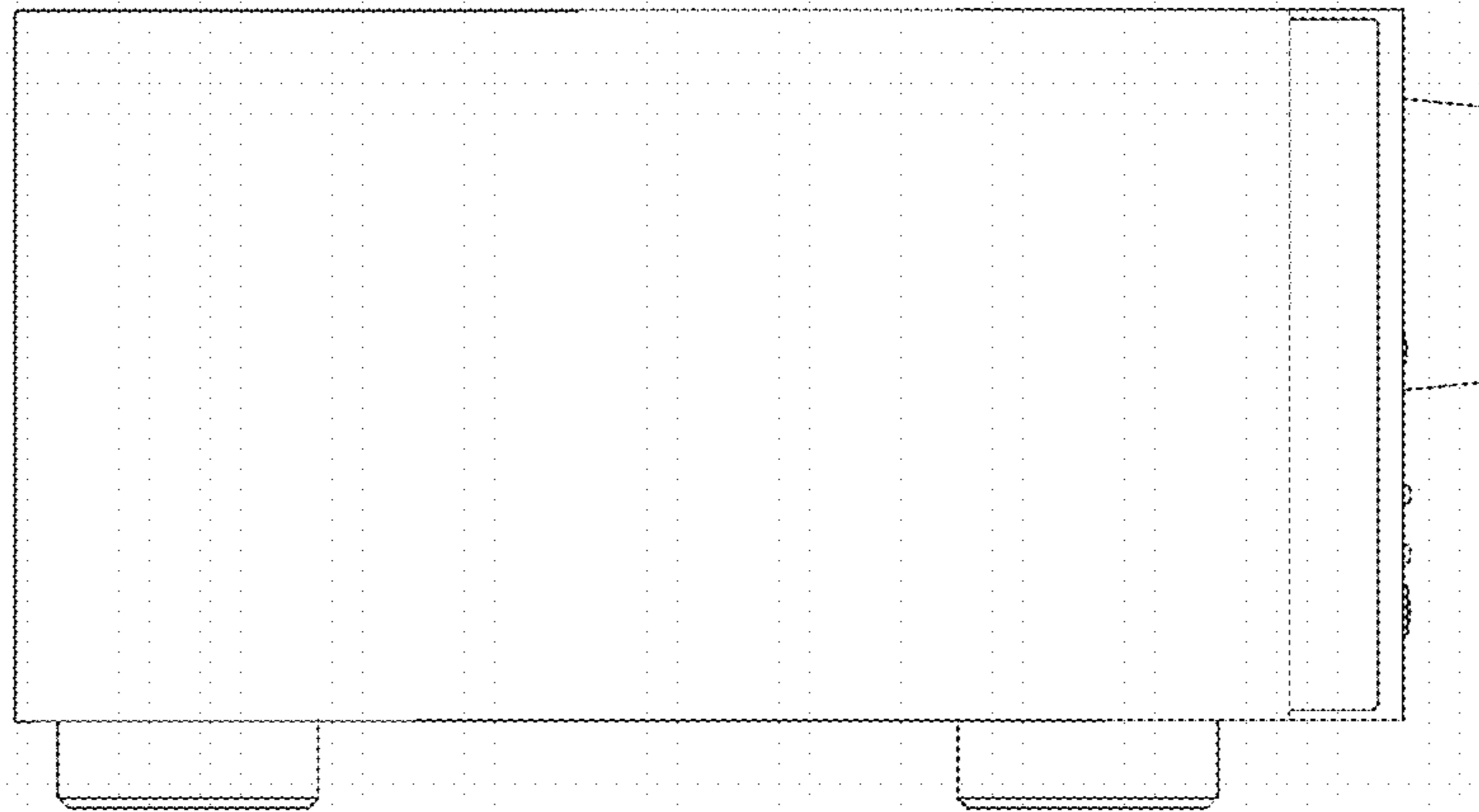

FIG. 4

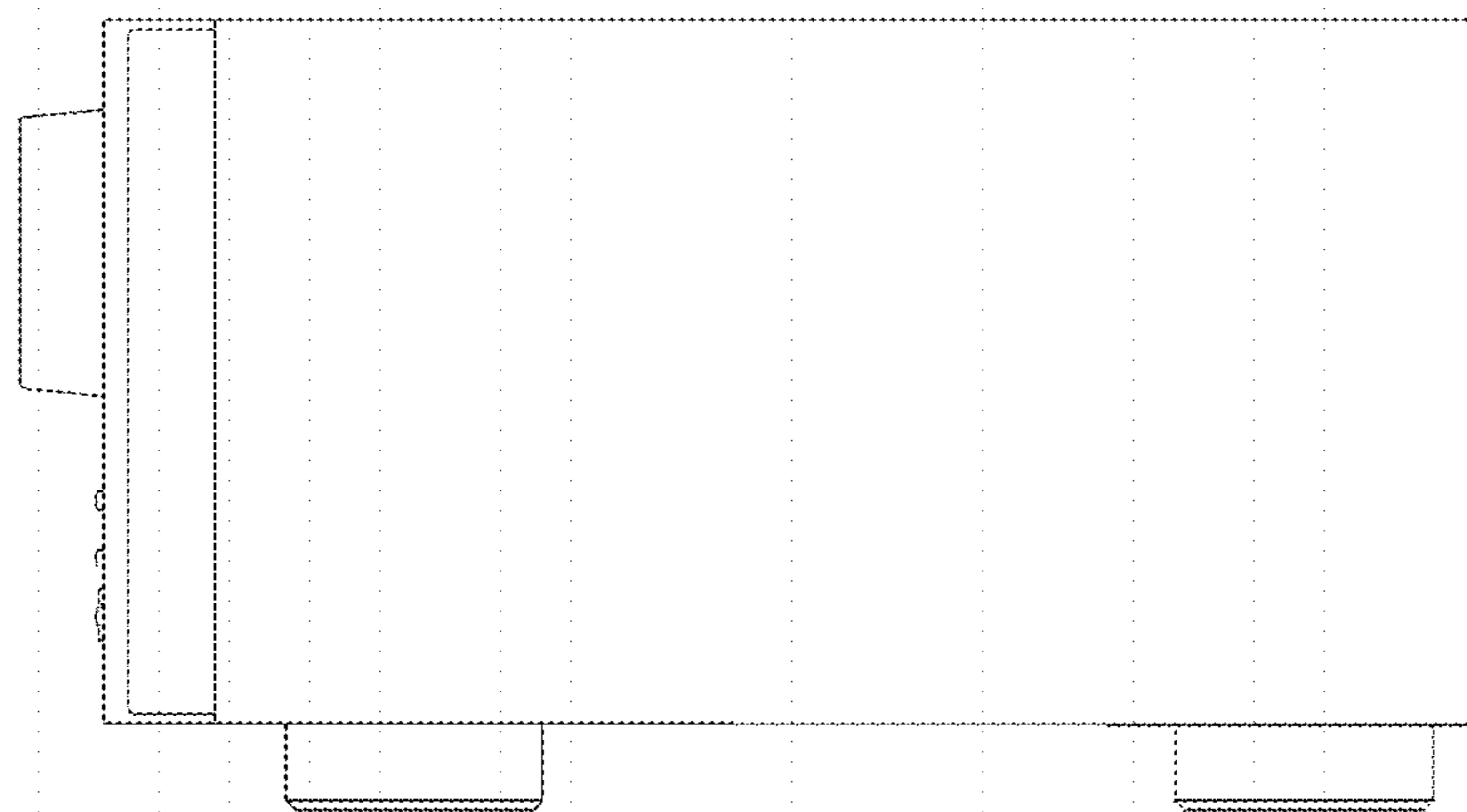

FIG. 5

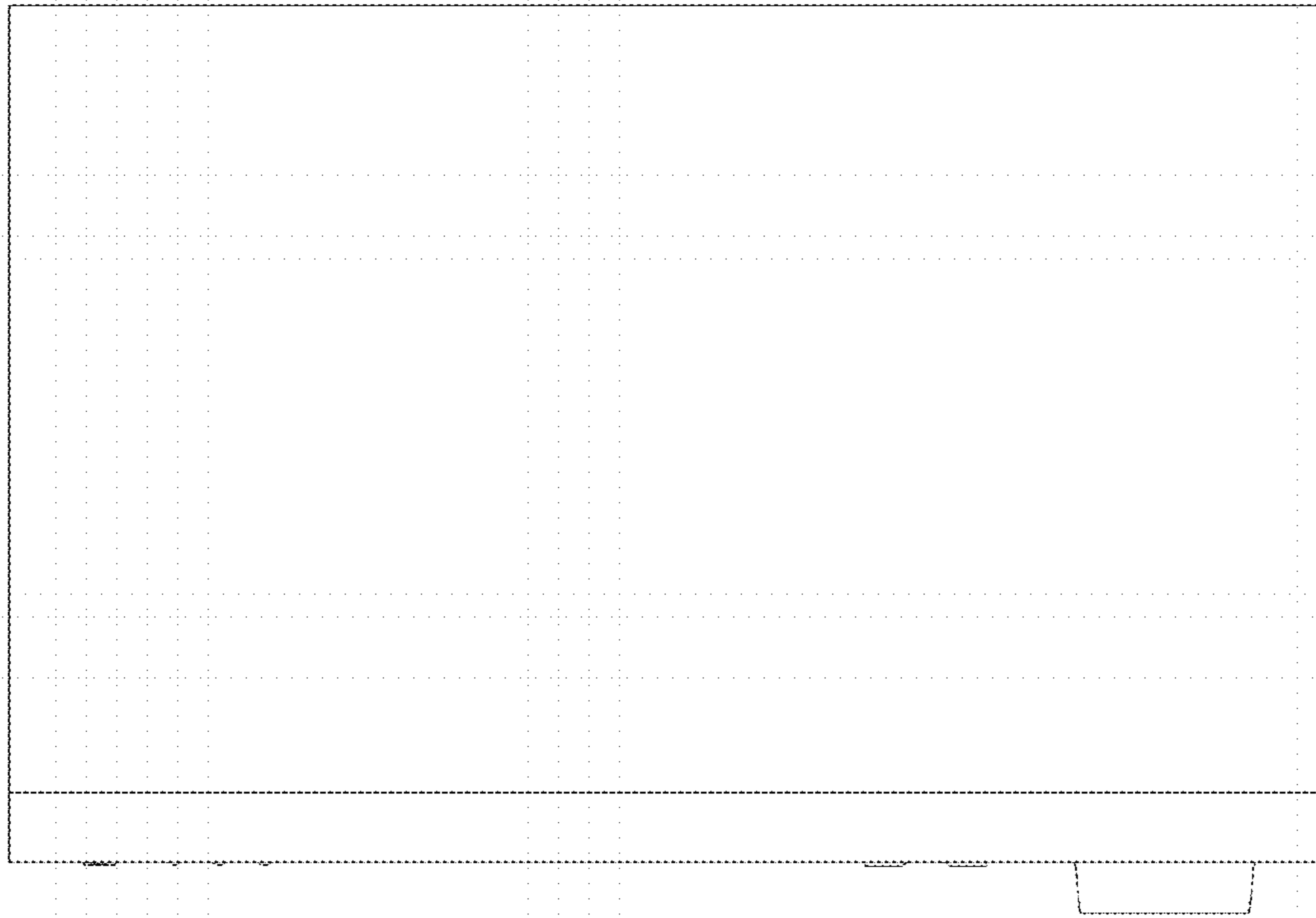

FIG. 6

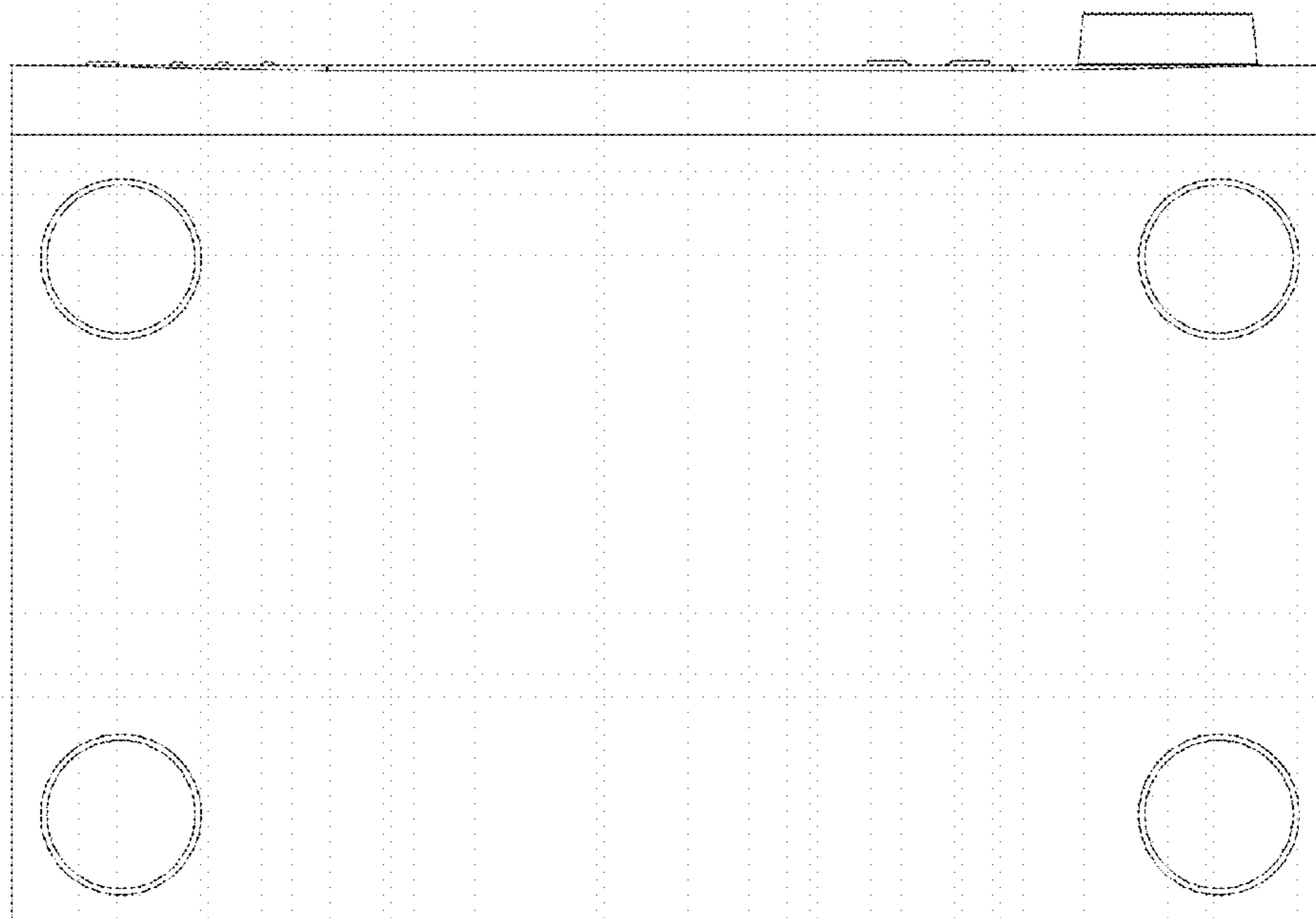

FIG. 7