

US00D767072S

(12) **United States Design Patent** (10) **Patent No.:** **US D767,072 S**  
**Dulisse et al.** (45) **Date of Patent:** **\*\* Sep. 20, 2016**

(54) **FIREARM SUPPRESSOR COVER**  
(71) Applicant: **Jamak Fabrication-Tex LLC**,  
Weatherford, TX (US)  
(72) Inventors: **Michael Lee Dulisse**, Graford, TX  
(US); **Steven Dean Henrickson**,  
Roanoke, TX (US)  
(73) Assignee: **Jamak Fabrication-Tex, LLC**,  
Weatherford, TX (US)  
(\*\*) Term: **14 Years**  
(21) Appl. No.: **29/515,988**  
(22) Filed: **Jan. 28, 2015**  
(51) **LOC (10) Cl.** ..... **22-01**  
(52) **U.S. Cl.**  
USPC ..... **D22/108**  
(58) **Field of Classification Search**  
USPC ..... D22/108  
CPC ..... F41A 21/30; F41A 21/325  
See application file for complete search history.

D579,595 S \* 10/2008 Shiu ..... D26/49  
D593,631 S \* 6/2009 Salva ..... D22/108  
D632,751 S 2/2011 Bowers et al.  
8,347,773 B2 1/2013 Schlenkert et al.  
8,397,615 B2 3/2013 Poling  
D682,974 S \* 5/2013 Honigmann ..... D22/108  
D682,975 S \* 5/2013 Honigmann ..... D22/108  
8,973,481 B2 \* 3/2015 Dueck ..... F41A 21/325  
181/223  
2007/0062090 A1 3/2007 Brindle  
2012/0125184 A1 \* 5/2012 Meyers ..... F41A 21/34  
89/14.2

(Continued)

**OTHER PUBLICATIONS**

[www.thefirearmblog.com/blog/2013/12/26/manta-m700-sound-suppressor-covers/](http://www.thefirearmblog.com/blog/2013/12/26/manta-m700-sound-suppressor-covers/).

(Continued)

*Primary Examiner* — Michael A Pratt  
(74) *Attorney, Agent, or Firm* — McGuireWoods, LLP

(57) **CLAIM**

We claim the ornamental design for a firearm suppressor cover, as shown and described.

**DESCRIPTION**

FIG. 1 is a perspective view of a firearm suppressor cover according to an illustrative embodiment;  
FIG. 2 is a front view of the firearm suppressor cover of FIG. 1;  
FIG. 3 is a right side view of the firearm suppressor cover of FIG. 1;  
FIG. 4 is a left side view of the firearm suppressor cover of FIG. 1; and,  
FIG. 5 is a perspective view showing a firearm suppressor mounted within the firearm suppressor cover of FIG. 1.  
The subject matter illustrated in dashed lines, and any surfaces of the design not shown, form no part of the claimed design.

**1 Claim, 5 Drawing Sheets**

(56) **References Cited**  
U.S. PATENT DOCUMENTS

|              |         |                 |         |
|--------------|---------|-----------------|---------|
| 2,965,994 A  | 12/1960 | Sullivan        |         |
| 4,346,643 A  | 8/1982  | Taylor et al.   |         |
| D279,812 S * | 7/1985  | Cellini         | 89/14.3 |
| 4,762,048 A  | 8/1988  | Higashi et al.  |         |
| 5,183,953 A  | 2/1993  | Anderson et al. |         |
| D344,351 S   | 2/1994  | Stagl           |         |
| D370,273 S   | 5/1996  | Stagl           |         |
| 5,661,920 A  | 9/1997  | Evans           |         |
| 5,778,590 A  | 7/1998  | Browning et al. |         |
| 5,850,706 A  | 12/1998 | Evans           |         |
| D427,669 S   | 7/2000  | Ruuska          |         |
| D475,798 S * | 6/2003  | Galli           | D26/37  |
| D476,103 S * | 6/2003  | Galli           | D26/37  |
| D501,054 S * | 1/2005  | Galli           | D26/37  |
| D549,860 S * | 8/2007  | Gustafson       | D26/37  |
| D577,449 S * | 9/2008  | Shiu            | D26/49  |
| D577,844 S * | 9/2008  | Shiu            | D26/49  |

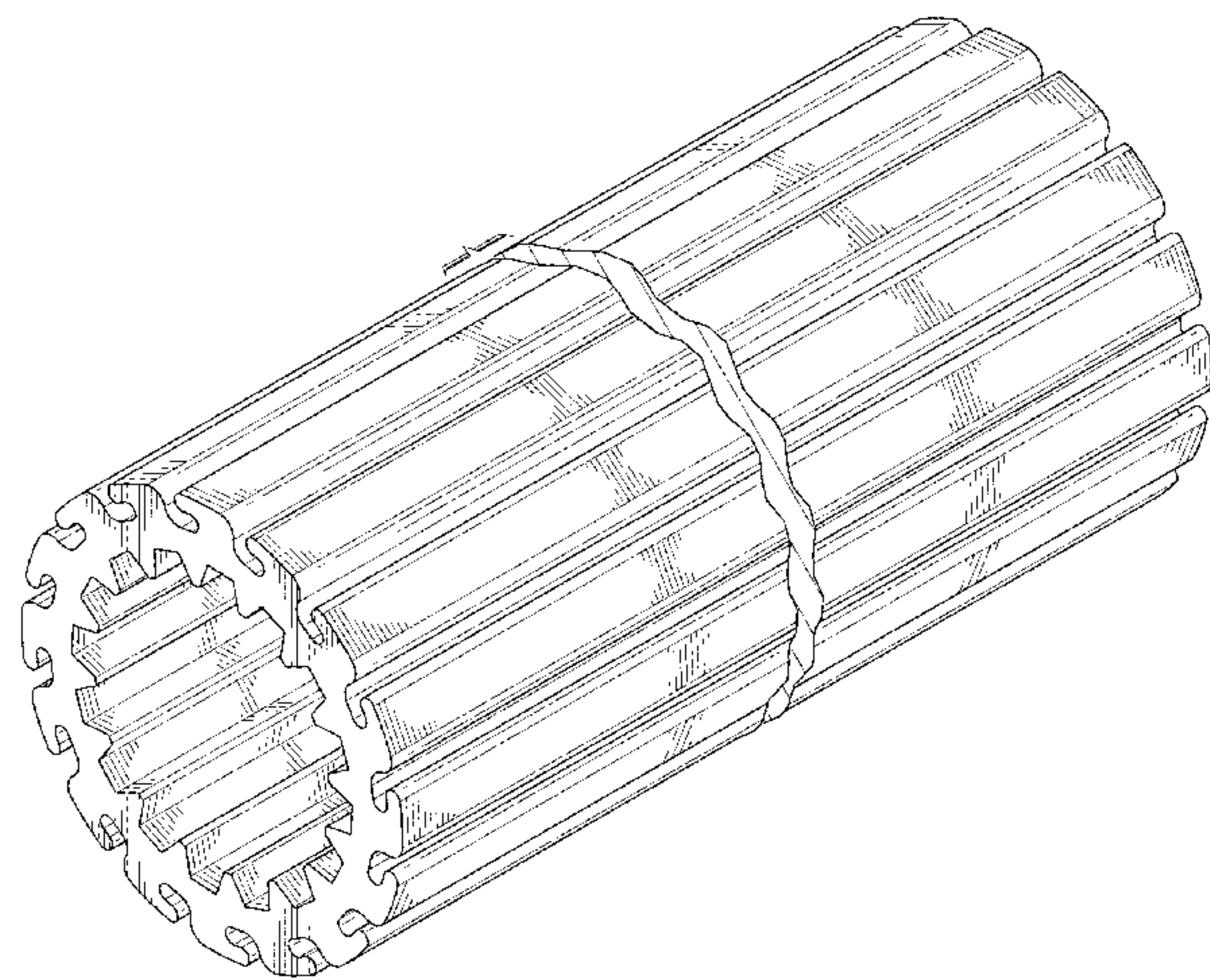

(56)

**References Cited**

OTHER PUBLICATIONS

U.S. PATENT DOCUMENTS

2012/0273083 A1 11/2012 Lin  
2013/0061503 A1 3/2013 W. et al.  
2014/0059913 A1 3/2014 Diamond et al.

[www.thefirearmblog.com/blog/2014/04/14/gear-review-bowers-group-griptastic-suppressor-covers/](http://www.thefirearmblog.com/blog/2014/04/14/gear-review-bowers-group-griptastic-suppressor-covers/).

\* cited by examiner

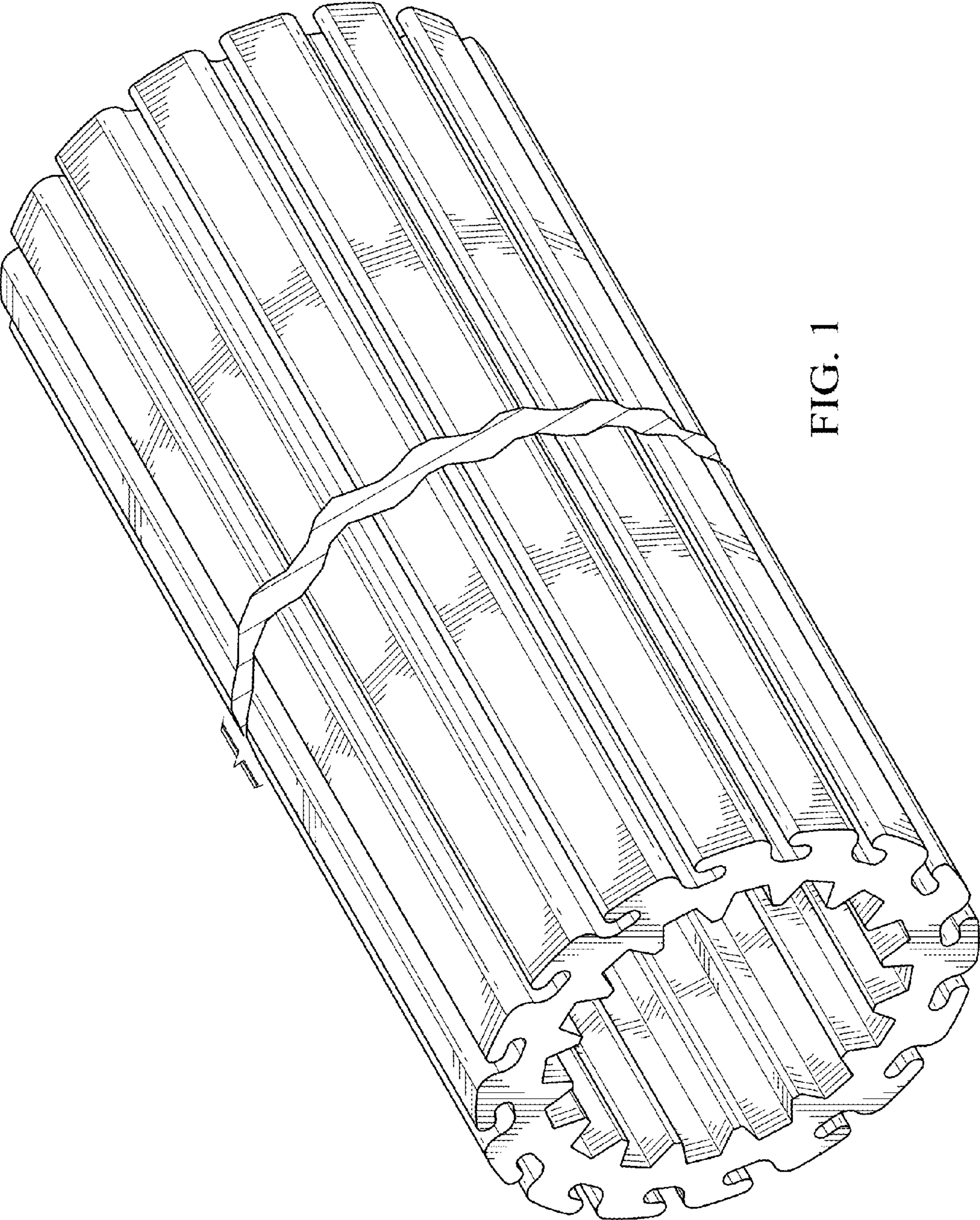

FIG. 1



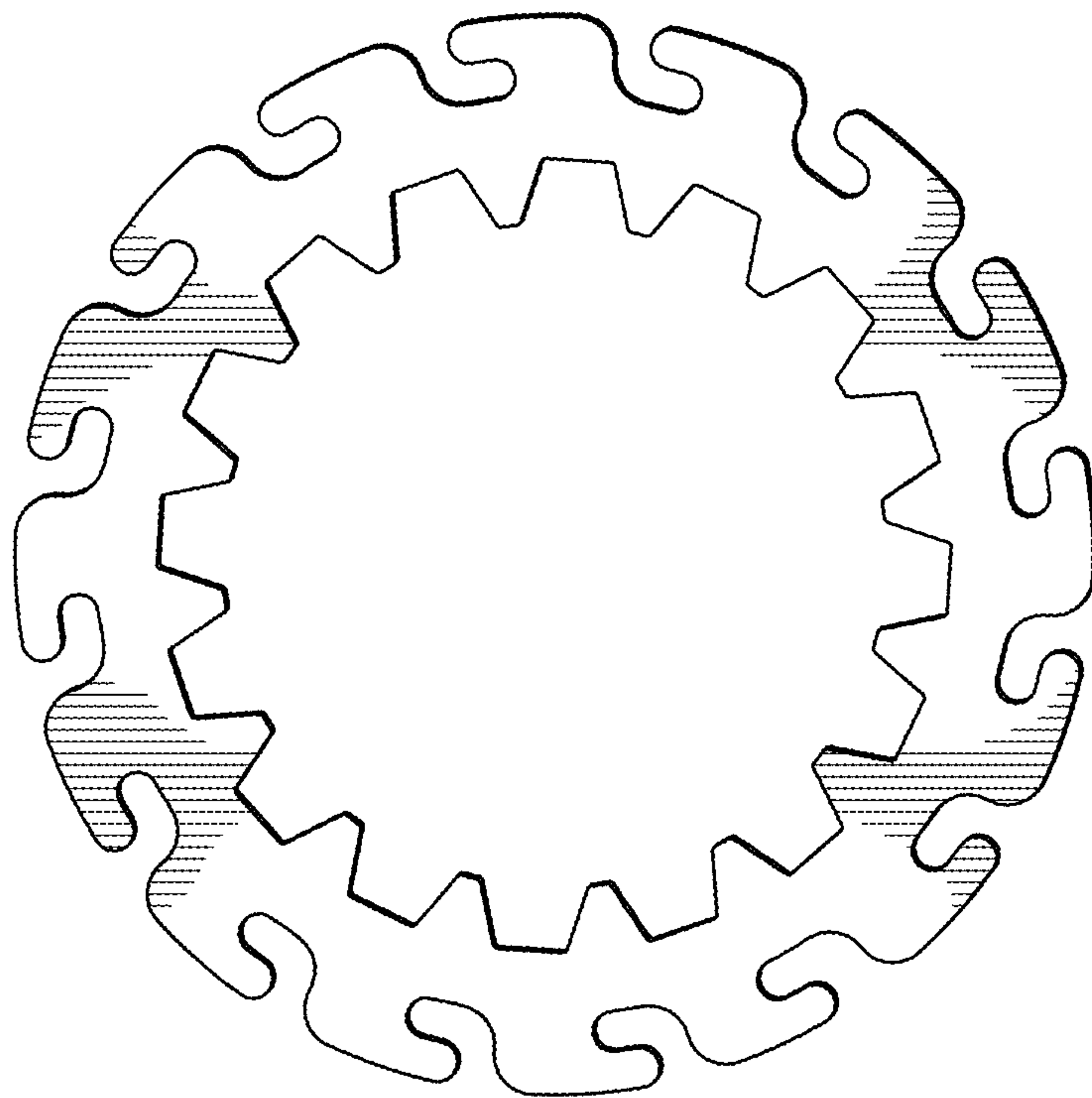

FIG. 2

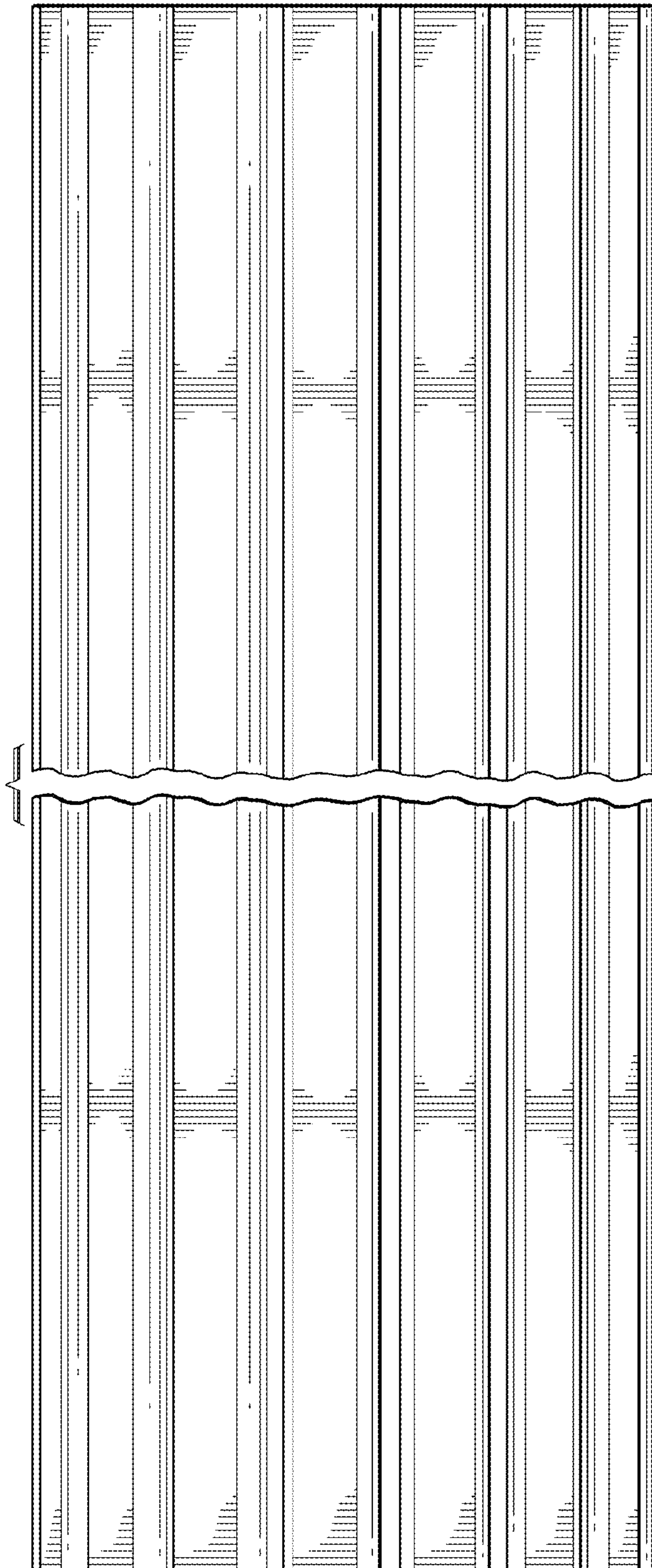

FIG. 3

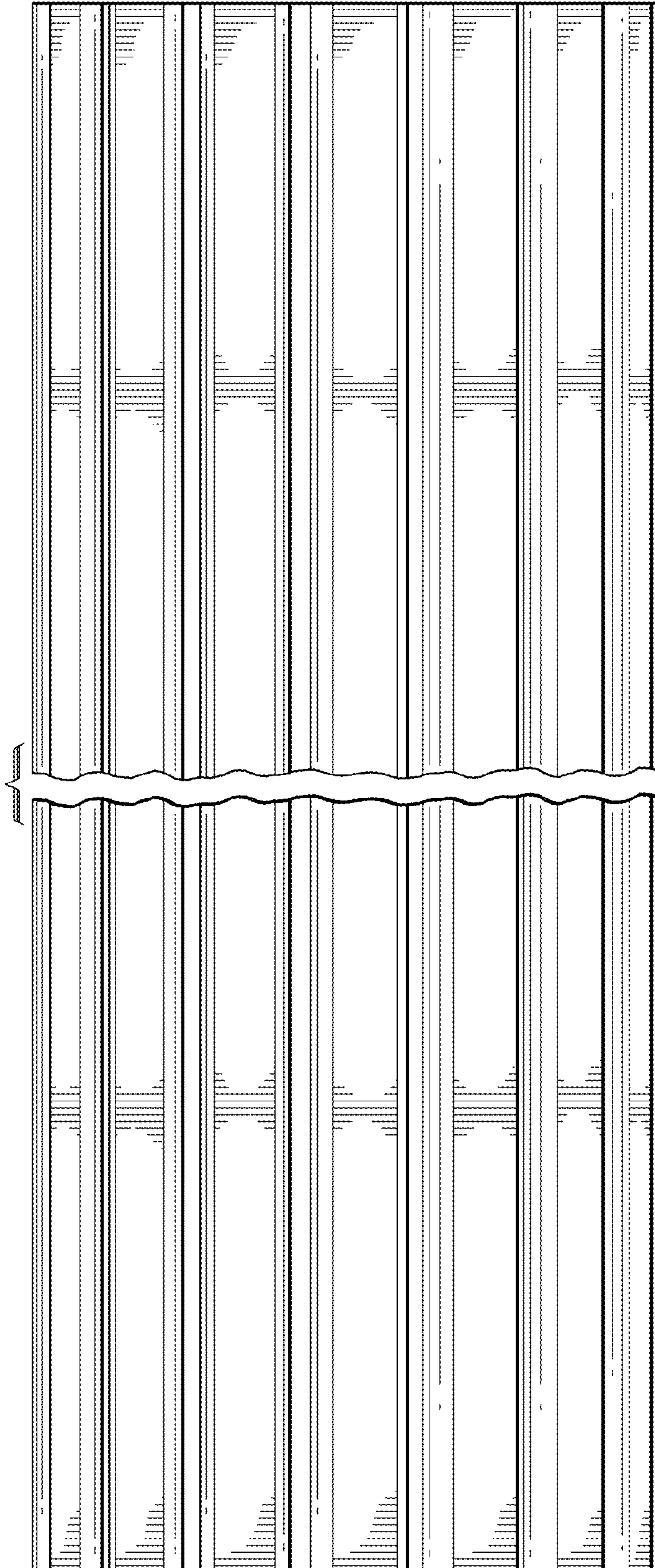

FIG. 4



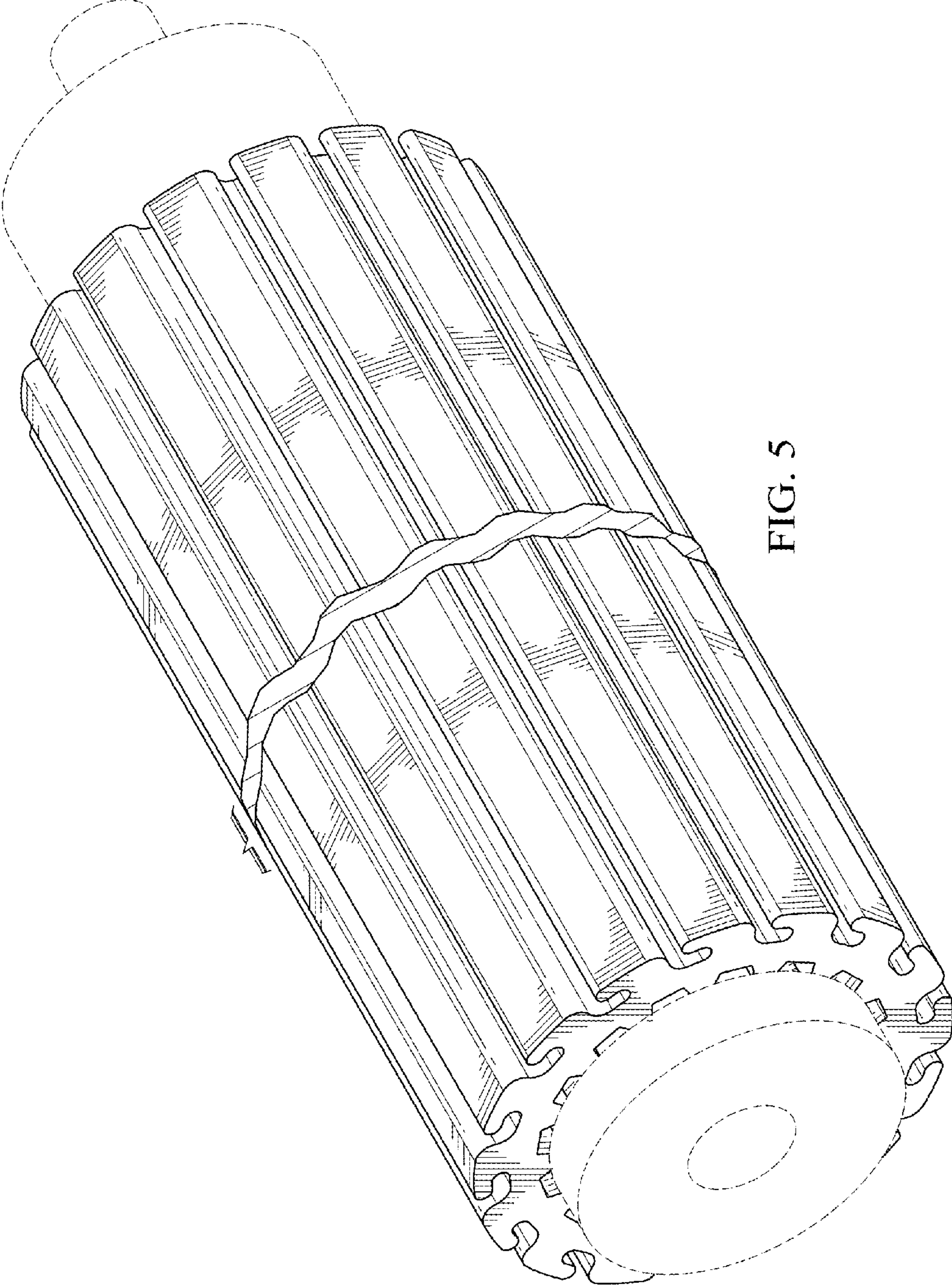

FIG. 5