



US00D766797S

(12) **United States Design Patent** (10) **Patent No.:** **US D766,797 S**
Li (45) **Date of Patent:** **** Sep. 20, 2016**

(54) **STEP FOR VEHICLES**
(71) Applicant: **M2 Distribution Ltd.**, Bellingham, WA (US)
(72) Inventor: **Ming Li**, Coquitlam (CA)
(73) Assignee: **M2 Distribution Ltd.**, Bellingham, WA (US)
(**) Term: **15 Years**
(21) Appl. No.: **29/529,992**
(22) Filed: **Jun. 11, 2015**
(51) **LOC (10) Cl.** **12-16**
(52) **U.S. Cl.**
USPC **D12/203**
(58) **Field of Classification Search**
USPC D12/203, 89, 314, 162, 190
CPC B60R 3/02; B60R 3/002; B60R 3/005;
B60R 3/00
See application file for complete search history.

(56) **References Cited**
U.S. PATENT DOCUMENTS
D400,485 S * 11/1998 Zentner D12/203
D488,759 S * 4/2004 Hattori D12/203
D495,283 S * 8/2004 Ashley D12/203
D505,901 S * 6/2005 Wang D12/203
D568,222 S * 5/2008 Storer D12/203
D596,098 S * 7/2009 Huang-Tsai D12/203
D632,627 S * 2/2011 Huang-Tsai D12/203
D634,687 S * 3/2011 Vukel D12/162
D645,805 S * 9/2011 Vukel D12/162
D649,100 S * 11/2011 Cheng D12/203
D658,559 S * 5/2012 Hodges D12/203
D665,713 S * 8/2012 Pochurek D12/203

D671,874 S * 12/2012 Kekich, Jr. D12/203
D673,890 S * 1/2013 Bundy D12/203
D676,368 S * 2/2013 Cover D12/203
8,864,158 B1 * 10/2014 Perkins B60R 3/002
280/163
D720,674 S * 1/2015 Stanesic D12/203
D731,384 S * 6/2015 Farr D12/203
D737,188 S * 8/2015 Perkins D12/203
D738,803 S * 9/2015 Zhu D12/203
D739,322 S * 9/2015 Villareal D12/203
D739,801 S * 9/2015 Bundy D12/203
D747,673 S * 1/2016 Wang D12/203

* cited by examiner
Primary Examiner — George D Kirschbaum
Assistant Examiner — Clese Moore, Jr.
(74) *Attorney, Agent, or Firm* — Michael R. Schacht;
Schacht Law Office, Inc.

(57) **CLAIM**
The new design for a step for vehicles, as shown and described herein.

DESCRIPTION
FIG. 1 is a perspective view of a step for vehicles;
FIG. 2 is a front view of the step for vehicles of FIG. 1;
FIG. 3 is a first side view of the step for vehicles of FIG. 1;
FIG. 4 is a second side view of the step for vehicles of FIG. 1;
FIG. 5 is a rear view of the step for vehicles of FIG. 1;
FIG. 6 is a top plan view of the step for vehicles of FIG. 1;
and,
FIG. 7 is a bottom plan view of the step for vehicles of FIG. 1.
The broken lines shown illustrate portions of the step for vehicles that forms no part of the claimed design.

1 Claim, 3 Drawing Sheets

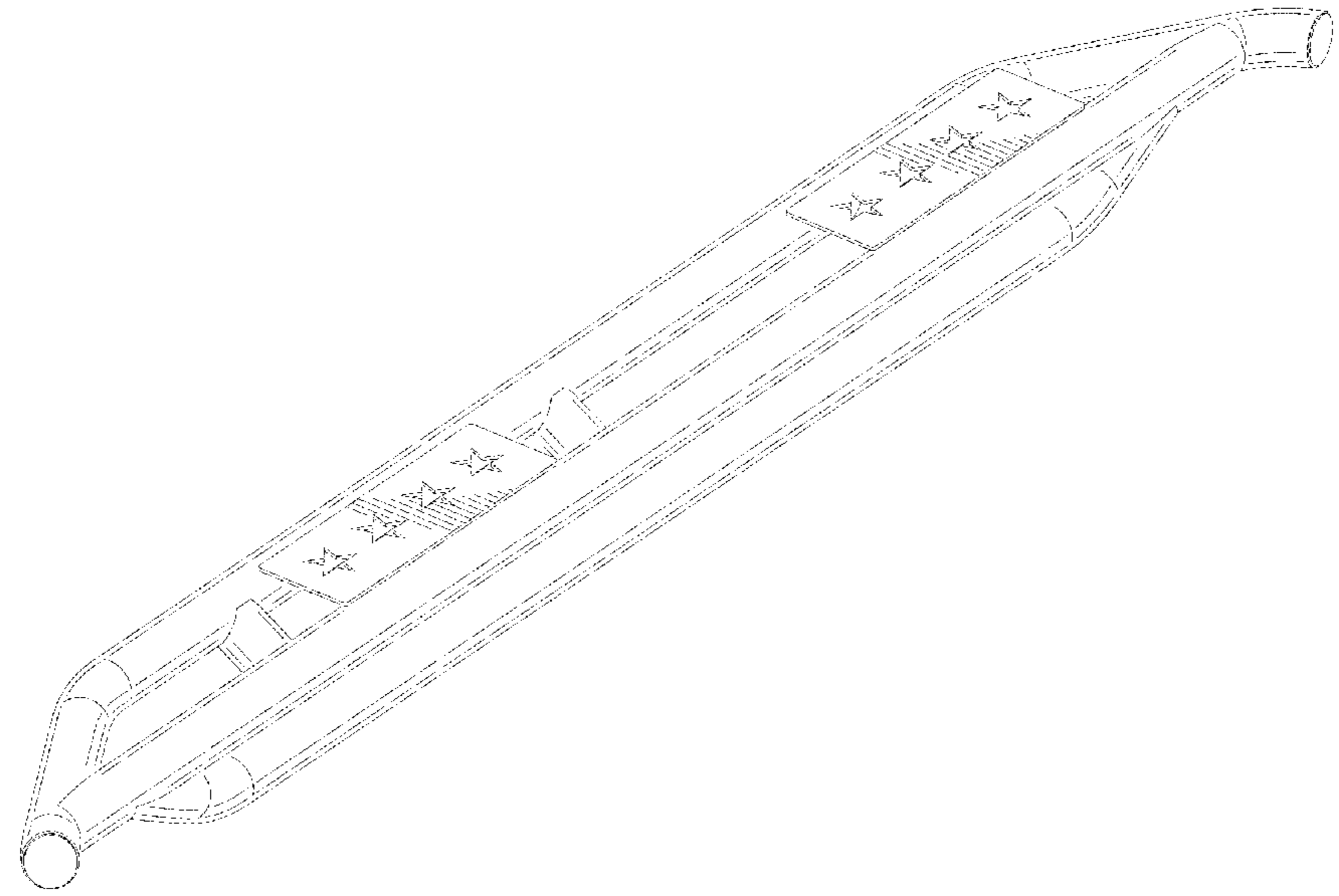

FIG. 1

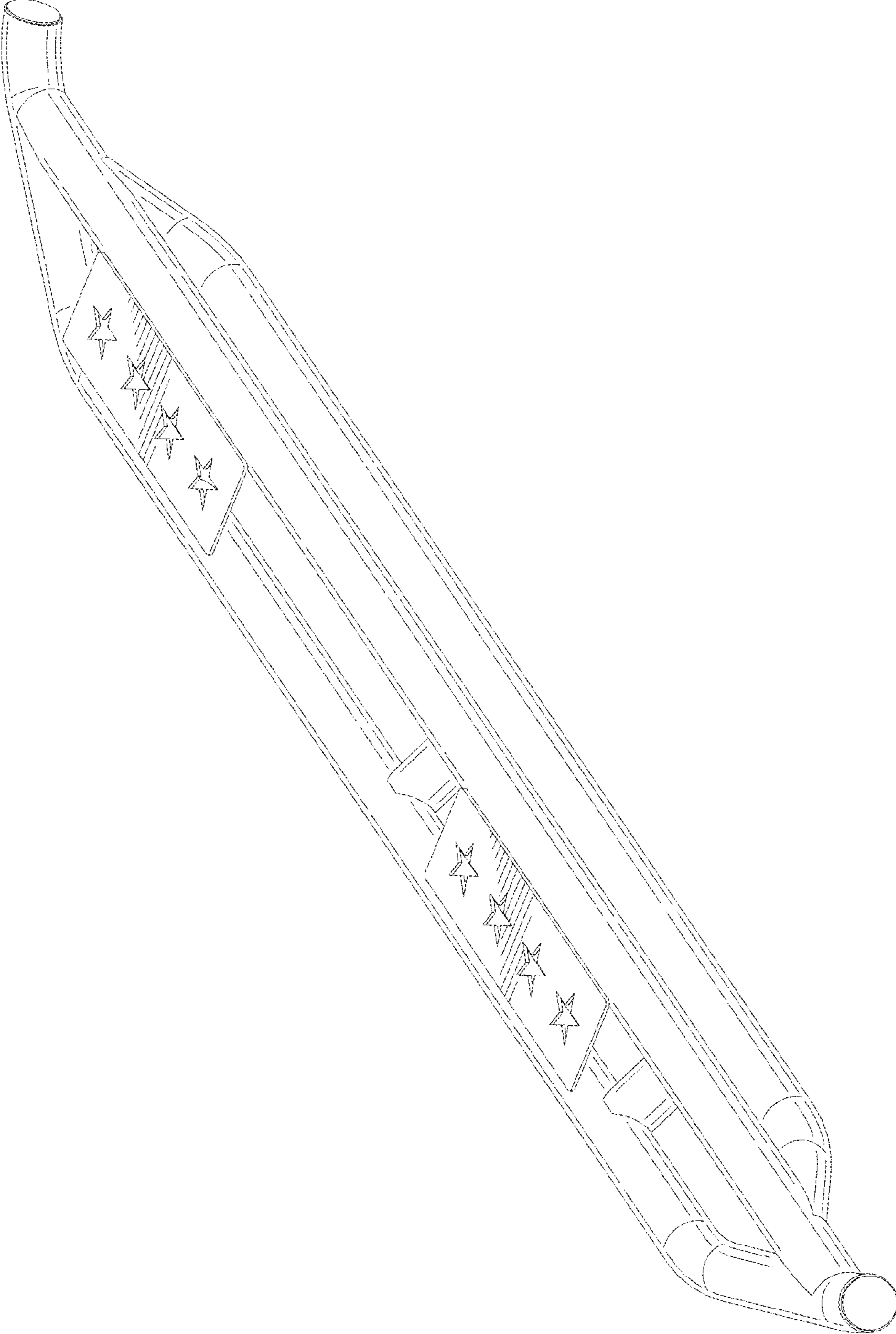

FIG. 2

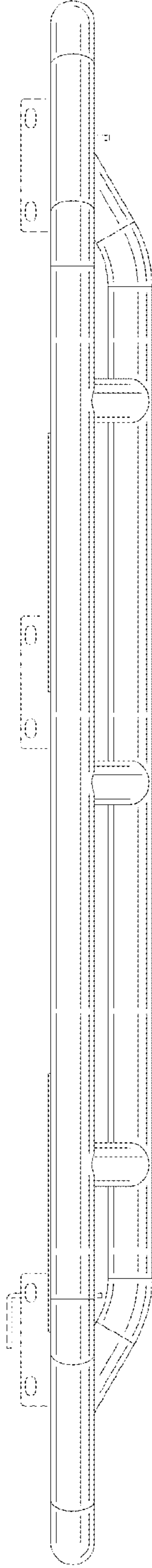

FIG. 4

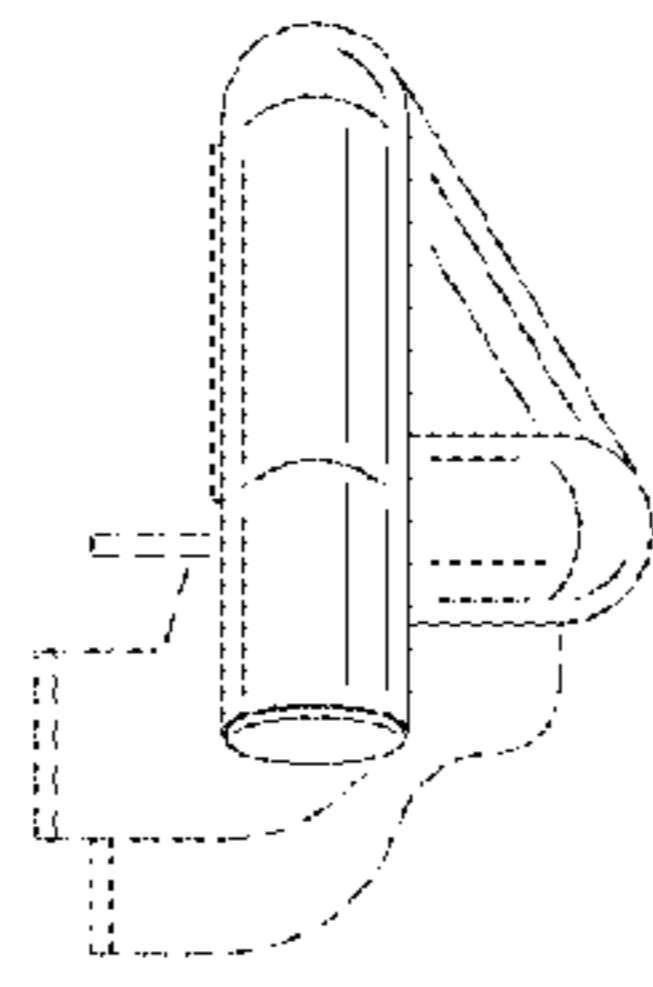

FIG. 3

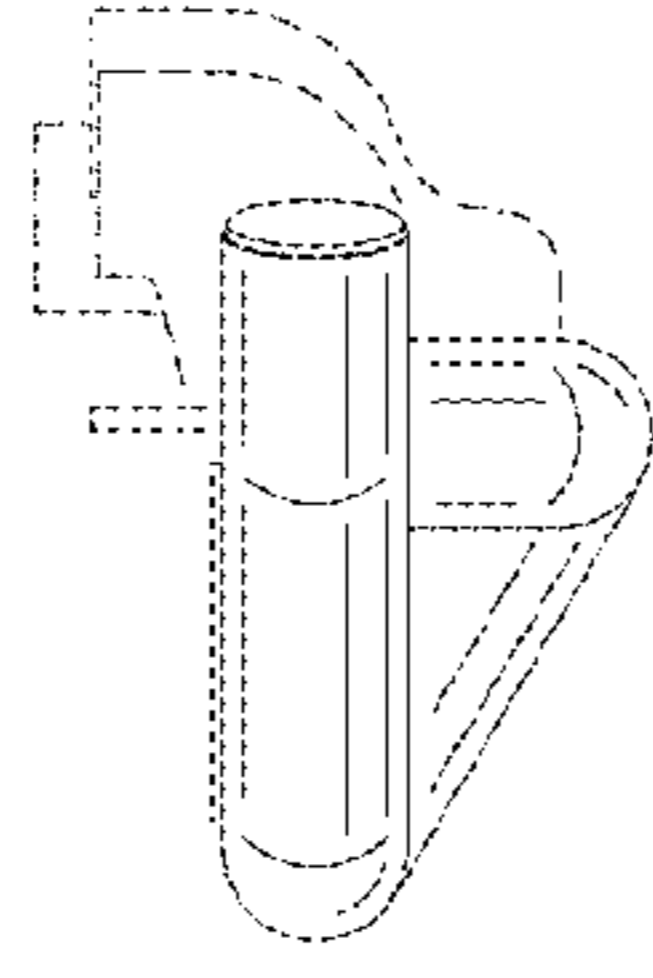

FIG. 5

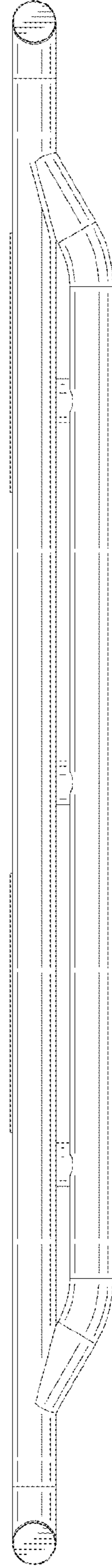

FIG. 6

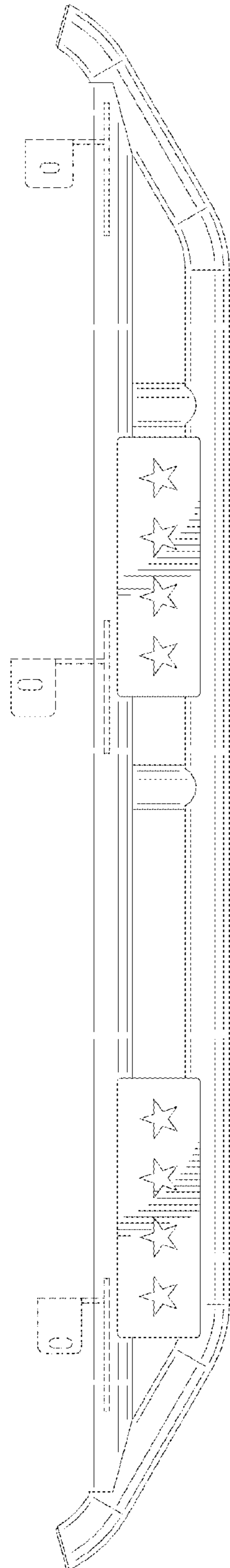

FIG. 7

