

US00D766653S

(12) **United States Design Patent**
Rosati et al.

(10) **Patent No.:** **US D766,653 S**

(45) **Date of Patent:** **** Sep. 20, 2016**

(54) **BEVERAGE MAKER**

(71) Applicant: **SPECTRUM BRANDS, INC.**,
Middleton, WI (US)

(72) Inventors: **Daniele Rosati**, Verona, WI (US);
Francisco J. Barquin, Madison, WI
(US); **Claudia Del Conte**, Madison, WI
(US)

(73) Assignee: **Spectrum Brands, Inc.**, Middleton, WI
(US)

(**) Term: **14 Years**

(21) Appl. No.: **29/509,333**

(22) Filed: **Nov. 17, 2014**

(51) **LOC (10) Cl.** **07-99**

(52) **U.S. Cl.**
USPC **D7/397; D7/399**

(58) **Field of Classification Search**
USPC D7/306-311, 305, 300, 313, 399, 398,
D7/397; 99/279, 284, 290, 280, 299, 307,
99/305, 295, 308, 309, 323.1, 395, 300;
222/23, 129.1; 62/395; D20/1;
D23/207, 209; D15/89
CPC A47J 31/44; A47J 31/00; B67D 1/0041;
B67D 3/00
See application file for complete search history.

(56) **References Cited**

U.S. PATENT DOCUMENTS

D505,292 S * 5/2005 Spencer D7/309
D550,499 S * 9/2007 Argabrite D7/309
D561,516 S * 2/2008 De Pra' D7/309
D562,052 S * 2/2008 De Pra' D7/309

D571,598 S * 6/2008 Moore D7/306
D584,097 S * 1/2009 Lam D7/305
D585,691 S * 2/2009 Borin D7/309
D589,739 S * 4/2009 Giugiaro D7/308
D592,003 S * 5/2009 Giugiaro D7/308
D600,060 S * 9/2009 Fletcher D7/306
D600,490 S * 9/2009 Pino D7/306
D624,780 S * 10/2010 Bodum D7/309
D627,188 S * 11/2010 Picozza D7/306
D630,471 S * 1/2011 Wang D7/306
D642,851 S * 8/2011 Yui D7/307
D648,971 S * 11/2011 Goralski D7/300
D649,391 S * 11/2011 Goralski D7/300
D669,295 S * 10/2012 Koury D7/309
D689,726 S * 9/2013 Romandy D7/309

* cited by examiner

Primary Examiner — Marianne Pandozzi

(74) *Attorney, Agent, or Firm* — Banner & Witcoff, Ltd.

(57) **CLAIM**

The ornamental design for a beverage maker, as shown and described.

DESCRIPTION

FIG. 1 is a perspective view of a beverage maker showing our new design;
FIG. 2 is a front view thereof;
FIG. 3 is the right side view thereof;
FIG. 4 is the left side view thereof; and,
FIG. 5 is the top view thereof.
The two vertical broken lines adjacent the lateral sides of the shaded area represent unclaimed boundaries of the design. The two vertical broken lines within the shaded area form no part of the claimed design. The broken line showing of the remainder of the beverage maker represents unclaimed subject matter and forms no part of the claimed design.

1 Claim, 5 Drawing Sheets

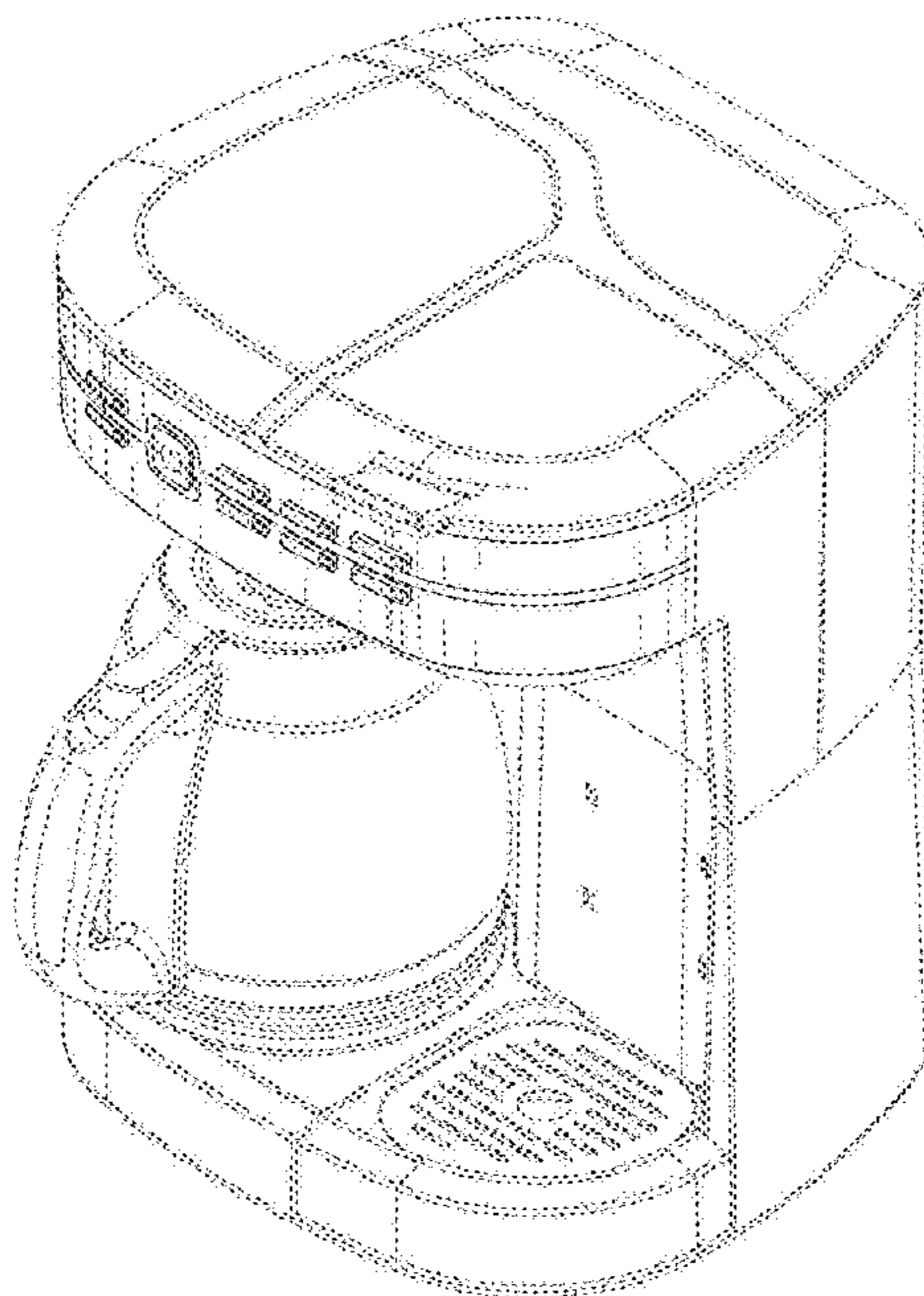

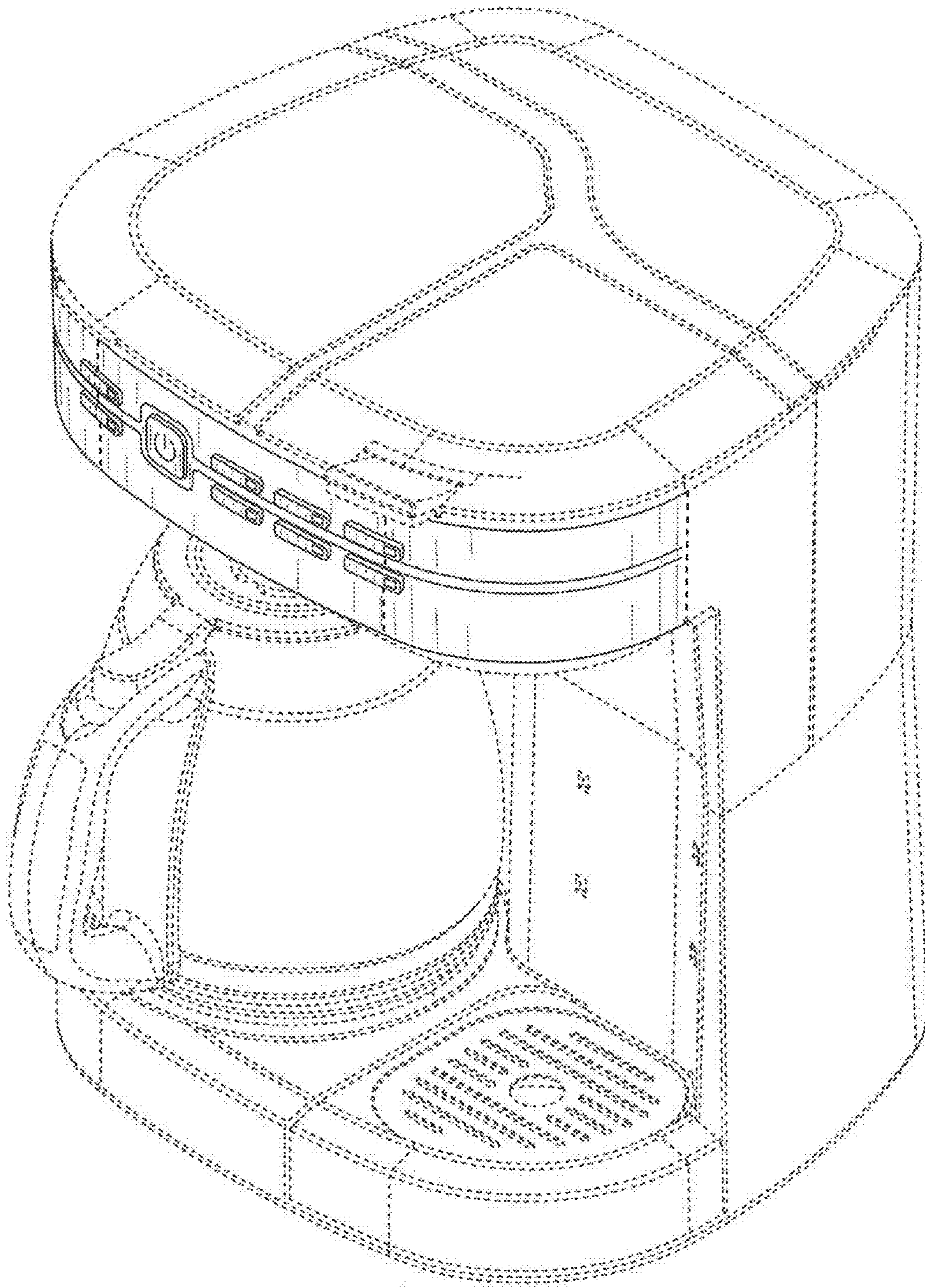

FIG. 1

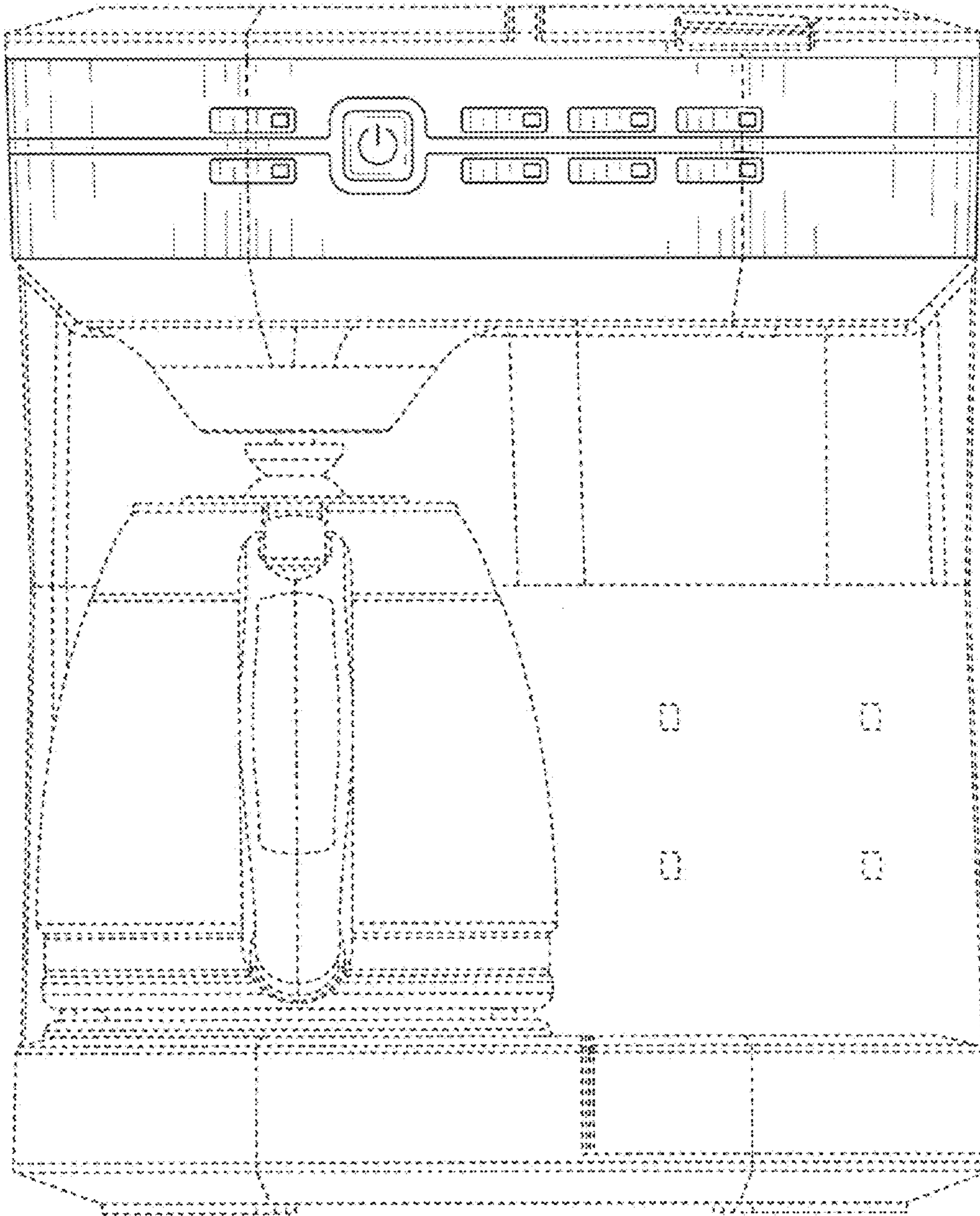

FIG. 2

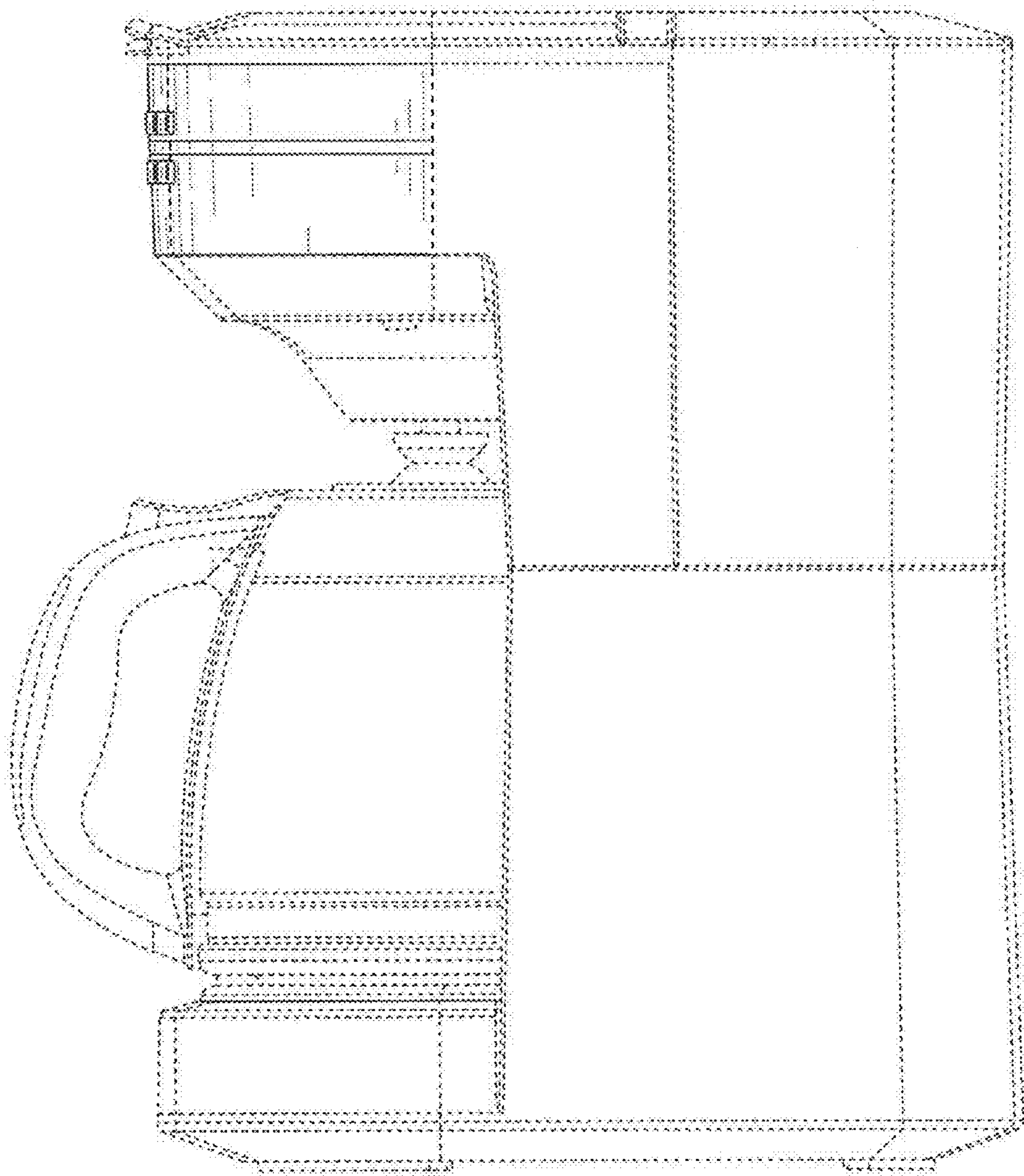

FIG. 3

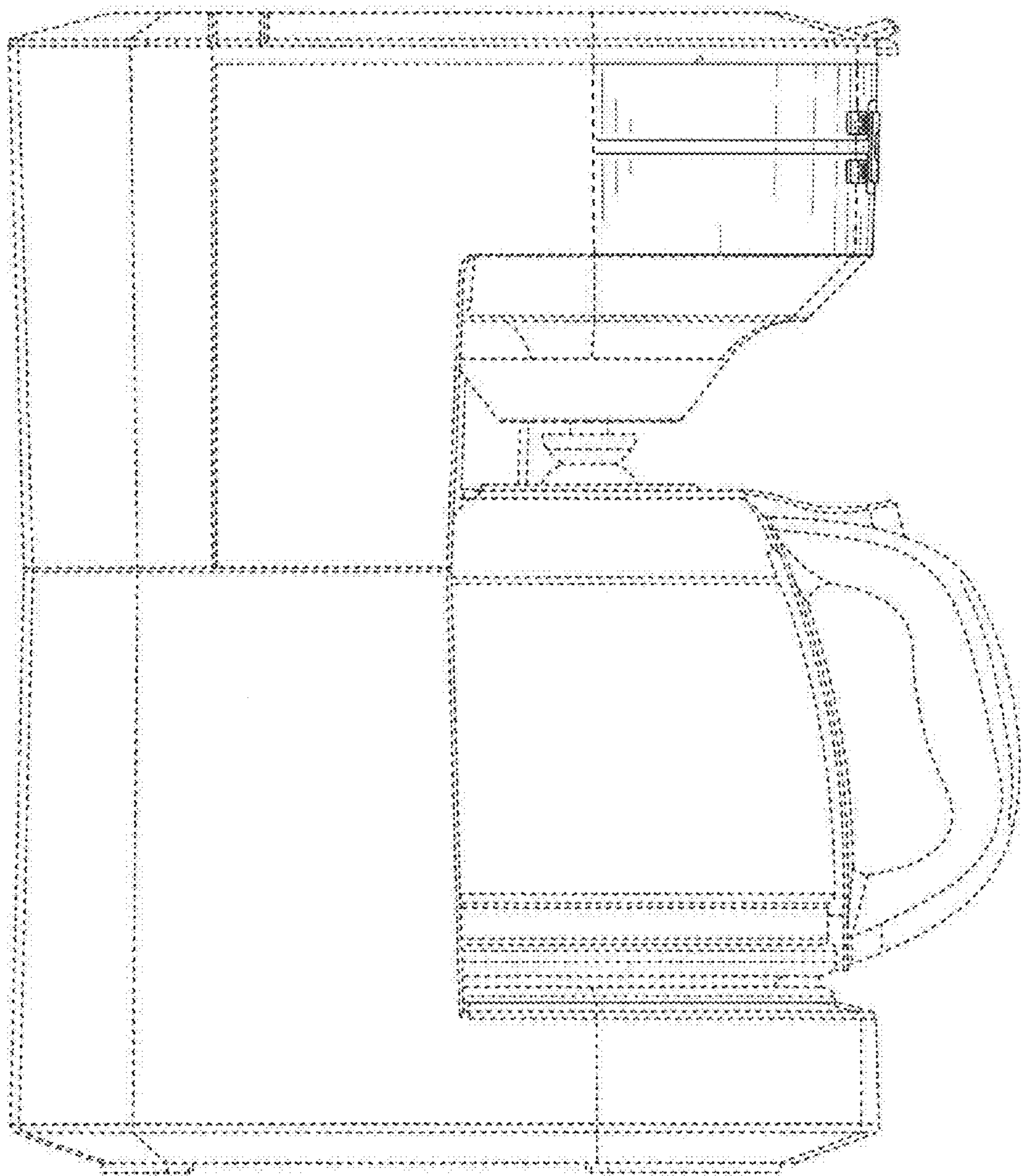

FIG. 4

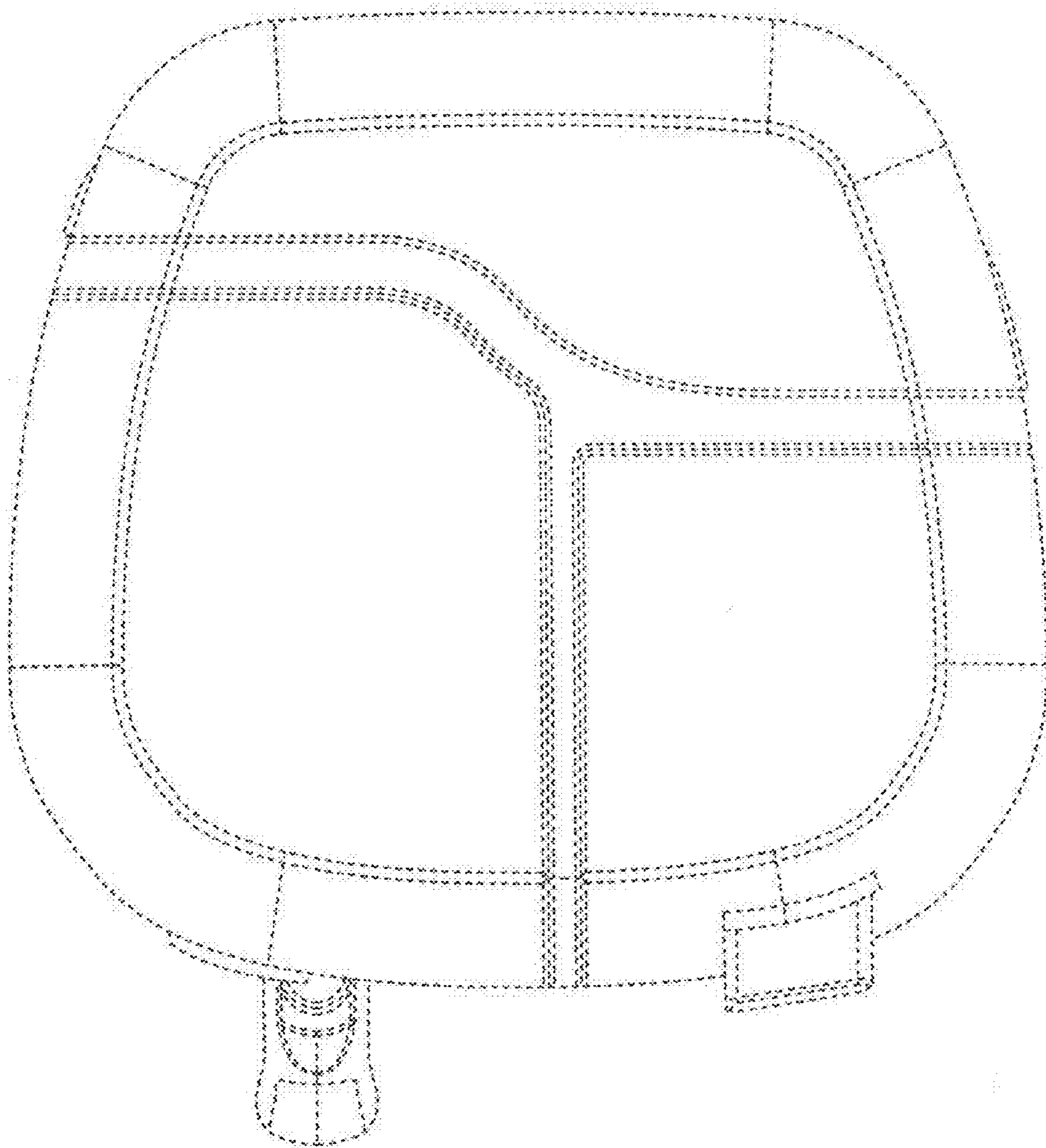

FIG. 5