

US00D766392S

(12) **United States Design Patent**
Wilson et al.

(10) **Patent No.:** **US D766,392 S**
(45) **Date of Patent:** **** Sep. 13, 2016**

(54) **FLAT BOTTOM VEE ICE SKATE BLADE**

(71) Applicant: **1339513 Ontario Ltd.**, Harrow (CA)

(72) Inventors: **Murray David Wilson**, Harrow (CA);
Steven David Wilson, Harrow (CA);
Omer Leon Hageniers, Windsor (CA)

(73) Assignee: **1339513 Ontario Ltd.**, Ontario (CA)

(**) Term: **15 Years**

(21) Appl. No.: **29/531,707**

(22) Filed: **Jun. 29, 2015**

Related U.S. Application Data

(63) Continuation of application No. 29/464,463, filed on Aug. 16, 2013, now Pat. No. Des. 733,240, which is a continuation of application No. 29/388,321, filed on Mar. 28, 2011, now Pat. No. Des. 688,343, which is

(Continued)

(51) **LOC (10) Cl.** **21-02**

(52) **U.S. Cl.**
USPC **D21/761**

(58) **Field of Classification Search**
USPC D21/760, 761, 762, 771, 772, 776;
280/7.13, 11.12, 11.15, 11.14, 11.17,
280/11.18, 11.223, 11.3, 825, 841
CPC A63C 1/00; A63C 1/30; A63C 1/32;
A63C 1/34; A63C 1/40; A63C 3/00; A63C
17/00; A63C 17/18; A63C 17/20
See application file for complete search history.

(56) **References Cited**

U.S. PATENT DOCUMENTS

60,431 A 12/1866 Scott et al.
83,339 A 10/1868 Thurston

(Continued)

FOREIGN PATENT DOCUMENTS

CA 1179696 12/1984
CA 2173001 2/1997

(Continued)

OTHER PUBLICATIONS

CA Office Action dated Dec. 13, 2011 for Canadian Application No. 2,630,749, filed May 6, 2008, entitled "Ice Skate Blade Sharpening Machine" to Hageniers et al., 3 pages.

(Continued)

Primary Examiner — Cynthia M Chin

(74) *Attorney, Agent, or Firm* — Remarck Law Group PLC

(57) **CLAIM**

The ornamental design for a flat bottom vee ice skate blade, as shown and described.

DESCRIPTION

FIG. 1 is a perspective view of a first embodiment of a flat bottom vee ice skate blade.

FIG. 2 is an enlarged front side view of the ice skate blade of FIG. 1.

FIG. 3 is an enlarged rear side view of the ice skate blade of FIG. 1.

FIG. 4 is a reduced top view of the ice skate blade of FIG. 1.

FIG. 5 is a reduced bottom view of the ice skate blade of FIG. 1.

FIG. 6 is a right side view of the ice skate blade of FIG. 1.

FIG. 7 is a left side view of the ice skate blade of FIG. 1.

FIG. 8 is a greatly enlarged close-up of the front side of FIG. 2.

FIG. 9 is a cross-sectional view of the ice skate blade taken from line 9-9 of FIG. 2.

FIG. 10 is a perspective view of a second embodiment of a flat bottom vee ice skate blade.

FIG. 11 is an enlarged front side view of the ice skate blade of FIG. 10.

FIG. 12 is an enlarged rear side view of the ice skate blade of FIG. 10. FIG. 13 is a reduced top view of the ice skate blade of FIG. 10.

FIG. 14 is a reduced bottom view of the ice skate blade of FIG. 10.

FIG. 15 is a right side view of the ice skate blade of FIG. 10.

FIG. 16 is a left side view of the ice skate blade of FIG. 10;

and,

FIG. 17 is a greatly enlarged close-up of the front side view of FIG. 11.

The broken line showing of portions of an ice skate is included for the purpose of illustrating environmental structure and forms no part of the claimed design.

1 Claim, 13 Drawing Sheets

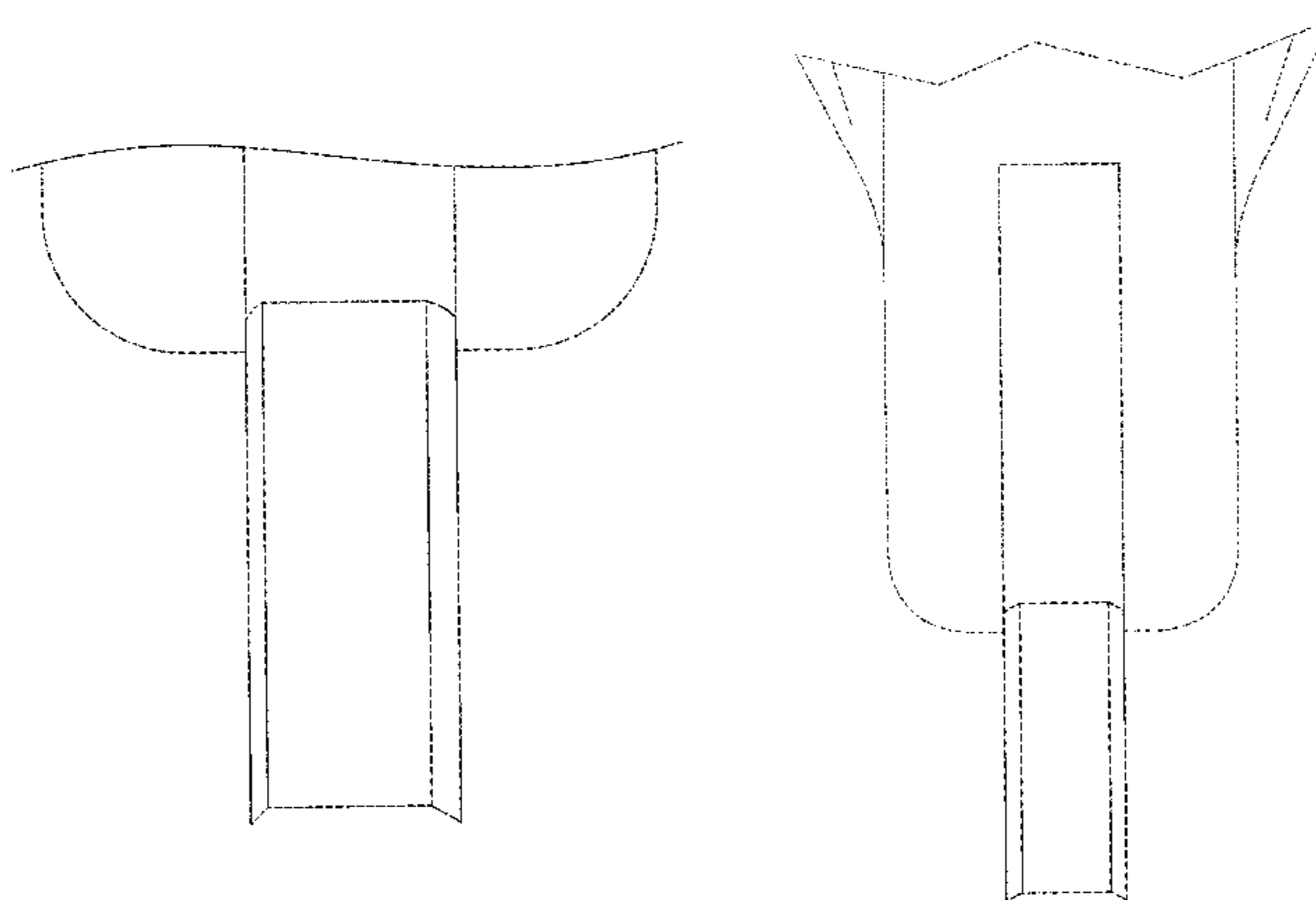

Related U.S. Application Data

a continuation-in-part of application No. 29/333,603, filed on Mar. 12, 2009, now Pat. No. Des. 637,676, and a continuation-in-part of application No. 12/402,838, filed on Mar. 12, 2009, now Pat. No. 8,056,907.

(56)

References Cited

U.S. PATENT DOCUMENTS

750,696	A	1/1904	Price	
1,100,976	A	6/1914	Hille	
1,181,831	A	5/1916	Browne	
1,786,553	A	12/1930	Thorngren	
1,826,958	A	10/1931	John	
2,055,665	A	9/1936	Moon	
2,150,964	A	3/1939	Hugo	
2,181,923	A	12/1939	Smolarek	
2,229,374	A	1/1941	Devau	
2,486,850	A	11/1949	Ives	
2,904,342	A	9/1959	Jones et al.	
3,271,906	A	9/1966	Esopi	
3,517,659	A	6/1970	Kane et al.	
3,735,533	A	5/1973	Salberg	
3,827,185	A	8/1974	Smith	
4,055,026	A	10/1977	Zwicker	
4,094,101	A	6/1978	Robinson	
4,114,913	A	9/1978	Newell et al.	
4,235,050	A	11/1980	Hannaford et al.	
4,271,635	A	6/1981	Szalay	
4,294,043	A	10/1981	Sakcriska	
D264,984	S	6/1982	Olivieri	
4,392,658	A	7/1983	Redmond et al.	
4,411,250	A	10/1983	Lach	
4,534,134	A	8/1985	Consay et al.	
4,535,571	A	8/1985	Smith	
4,615,144	A	10/1986	Peacock et al.	
4,722,152	A	2/1988	Ek et al.	
4,756,125	A	7/1988	Kadnar	
4,805,586	A	2/1989	Borse	
4,907,813	A	3/1990	Hall	
5,009,039	A	4/1991	Lager et al.	
5,248,156	A	9/1993	Cann et al.	
5,287,657	A	2/1994	Tschida et al.	
5,332,242	A	7/1994	Cann et al.	
5,348,079	A	9/1994	Tanaka	
5,354,078	A	10/1994	Belleisle	
5,431,597	A	7/1995	Anderson	
5,441,100	A	8/1995	Ueda et al.	
5,445,050	A	8/1995	Owens	
5,499,556	A	3/1996	Exner et al.	
5,547,416	A	8/1996	Timms	
D373,399	S	9/1996	Both	
D373,807	S	9/1996	Swande	
5,570,893	A	11/1996	Swande	
5,591,069	A	1/1997	Wurthman	
5,641,169	A	6/1997	Bekessy	
5,704,829	A	1/1998	Long	
5,725,419	A	3/1998	Osthoff et al.	
5,769,434	A *	6/1998	Wurthner A63C 1/30 280/11.12	
D396,515	S *	7/1998	Venier D21/762	
5,826,890	A	10/1998	Swande	
5,975,197	A	11/1999	Kado	
6,030,283	A	2/2000	Anderson	
6,109,622	A *	8/2000	Reynolds A63C 1/303 280/11.17	
6,113,474	A	9/2000	Shih et al.	
6,116,989	A	9/2000	Balastik	
6,203,028	B1	3/2001	Kress	
6,234,532	B1 *	5/2001	Kollen A63C 1/30 280/11.12	
6,286,498	B1	9/2001	Sung	
6,308,700	B1	10/2001	Lierse	
6,318,738	B1 *	11/2001	Abkowitz A63C 1/30 280/11.18	
6,368,198	B1	4/2002	Sung et al.	

6,422,934	B1	7/2002	Blach et al.	
6,443,819	B2	9/2002	Sakcriska	
6,467,778	B1	10/2002	Goldsmith et al.	
6,481,113	B1	11/2002	Brenner et al.	
6,619,674	B2	9/2003	Baldwin	
6,620,523	B2	9/2003	Abkowitz et al.	
6,695,322	B2	2/2004	Goldsmith et al.	
D500,112	S	12/2004	Brumpton	
6,830,251	B2	12/2004	Titzmann	
6,953,390	B2	10/2005	Sakurai et al.	
D514,643	S	2/2006	Henderson	
7,073,810	B2	7/2006	Wilson	
7,234,709	B2	6/2007	Lambert	
D555,180	S	11/2007	Amamoto et al.	
7,380,801	B2	6/2008	Rudolph	
7,387,302	B2	6/2008	Goldsmith et al.	
7,559,828	B2	7/2009	Liao	
D603,432	S	11/2009	Wilson et al.	
7,648,146	B2	1/2010	Tatomir	
7,673,884	B2 *	3/2010	Wuerthner A63C 1/32 280/11.12	
D626,978	S	11/2010	Huh	
D631,120	S	1/2011	Salmon	
7,866,675	B2 *	1/2011	Hauser A63C 1/303 280/11.12	
D637,676	S	5/2011	Wilson et al.	
7,934,978	B2	5/2011	Wilson et al.	
8,056,907	B2 *	11/2011	Wilson A63C 1/32 280/11.12	
D665,830	S	8/2012	Wilson et al.	
8,277,284	B2	10/2012	Wilson et al.	
D681,077	S	4/2013	Wilson et al.	
D688,343	S *	8/2013	Wilson D21/761	
8,574,030	B2	11/2013	Wilson et al.	
D701,890	S	4/2014	Wilson et al.	
2001/0052678	A1	12/2001	Titzmann	
2002/0014041	A1	2/2002	Baldoni et al.	
2003/0106270	A1	6/2003	Baldoni et al.	
2003/0234499	A1 *	12/2003	Rudolph A63C 1/30 280/11.18	
2004/0157537	A1	8/2004	Tatum et al.	
2005/0276979	A1	12/2005	Slutz et al.	
2006/0040584	A1	2/2006	Ray et al.	
2006/0183411	A1	8/2006	Moon	
2007/0001426	A1	1/2007	Wade	
2008/0051013	A1	2/2008	Burgess	
2009/0206563	A1	8/2009	Ferras	
2009/0273149	A1	11/2009	Wilson et al.	
2010/0194062	A1	8/2010	Hauser	
2010/0201088	A1	8/2010	Newman et al.	

FOREIGN PATENT DOCUMENTS

CA	2373449	11/2000
WO	0067949	11/2000

OTHER PUBLICATIONS

CA Office Action dated Jun. 13, 2011 for Canadian Application No. 2,663,095, filed Apr. 16, 2009, entitled "Ice Skate Blades" to Wilson et al., 2 pages.

CA Office Action dated Jun. 8, 2011 for Canadian Application No. 2,630,749, filed May 6, 2008, entitled "Ice Skate Blade Sharpening Machine" to Hageniers et al., 3 pages.

Office Action dated Feb. 15, 2012 for U.S. Appl. No. 13/073,497, entitled "Ice Skate Blades and Sharpening Machines" to Wilson et al., 19 pages.

Office Action dated Mar. 25, 2011 for U.S. Appl. No. 12/402,838, filed Mar. 12, 2009, entitled "Ice Skate Blades" to Wilson et al., 15 pages.

Office Action dated Mar. 5, 2013 for U.S. Appl. No. 13/600,348, filed Aug. 31, 2012, entitled "Method of Making an Ice Skate Blade" to Wilson et al., 9 pages.

Office Action dated Nov. 26, 2010 for U.S. Appl. No. 12/402,838, filed Mar. 12, 2009, entitled "Ice Skate Blades" to Wilson et al., 20 pages.

(56)

References Cited

OTHER PUBLICATIONS

Office Action dated Nov. 9, 2010 for U.S. Appl. No. 12/114,191, filed May 2, 2008, entitled "Ice Skate Blade Sharpening Machine" to Wilson et al., 9 pages.

Office Action dated Oct. 6, 2010 for U.S. Appl. No. 12/114,191, filed May 2, 2008, entitled "Ice Skate Blade Sharpening Machine" to Wilson et al., 20 pages.

Printout purporting to be a portion of Abrasive Technology, Manufacturer of Diamond & CBN Tooling: Resin & Metal Bonded

Product Line and including a copyright notice date of 2004 on the final page, 11 pages.

Printout purporting to be a portion of Norton Stock Catalog 2005-2006 Diamond Tools and bearing no date, 16 pages.

Printout purporting to be a webpage of Norton Abrasives from 2006 and bearing a date of Jul. 29, 2011, 1 page.

Submission of Prior Art Under Provisions of Section 34 for Canadian Application No. 2,630,749 dated Jul. 29, 2011, 141 pages including 6 Exhibits.

* cited by examiner

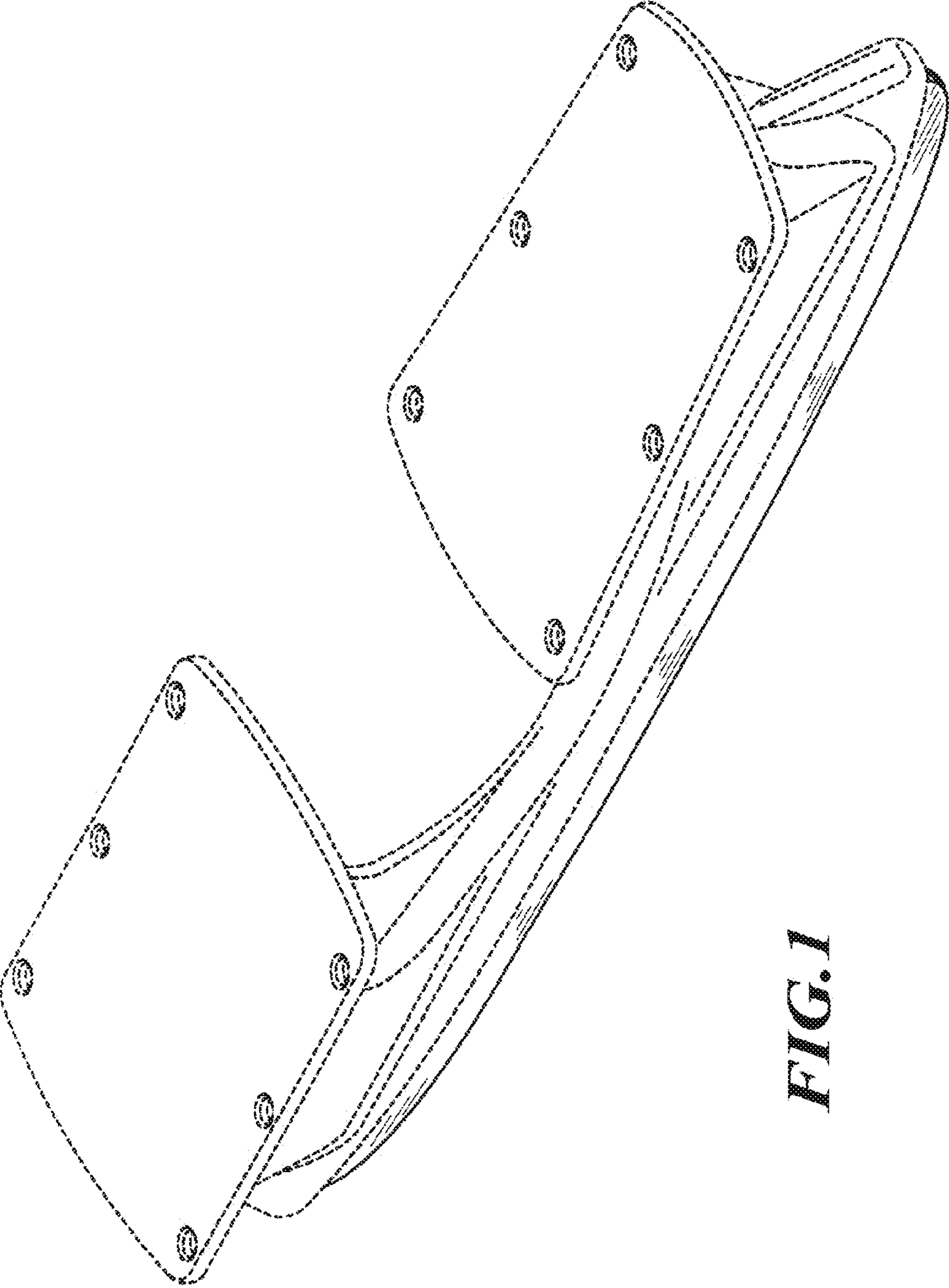

FIG. 1

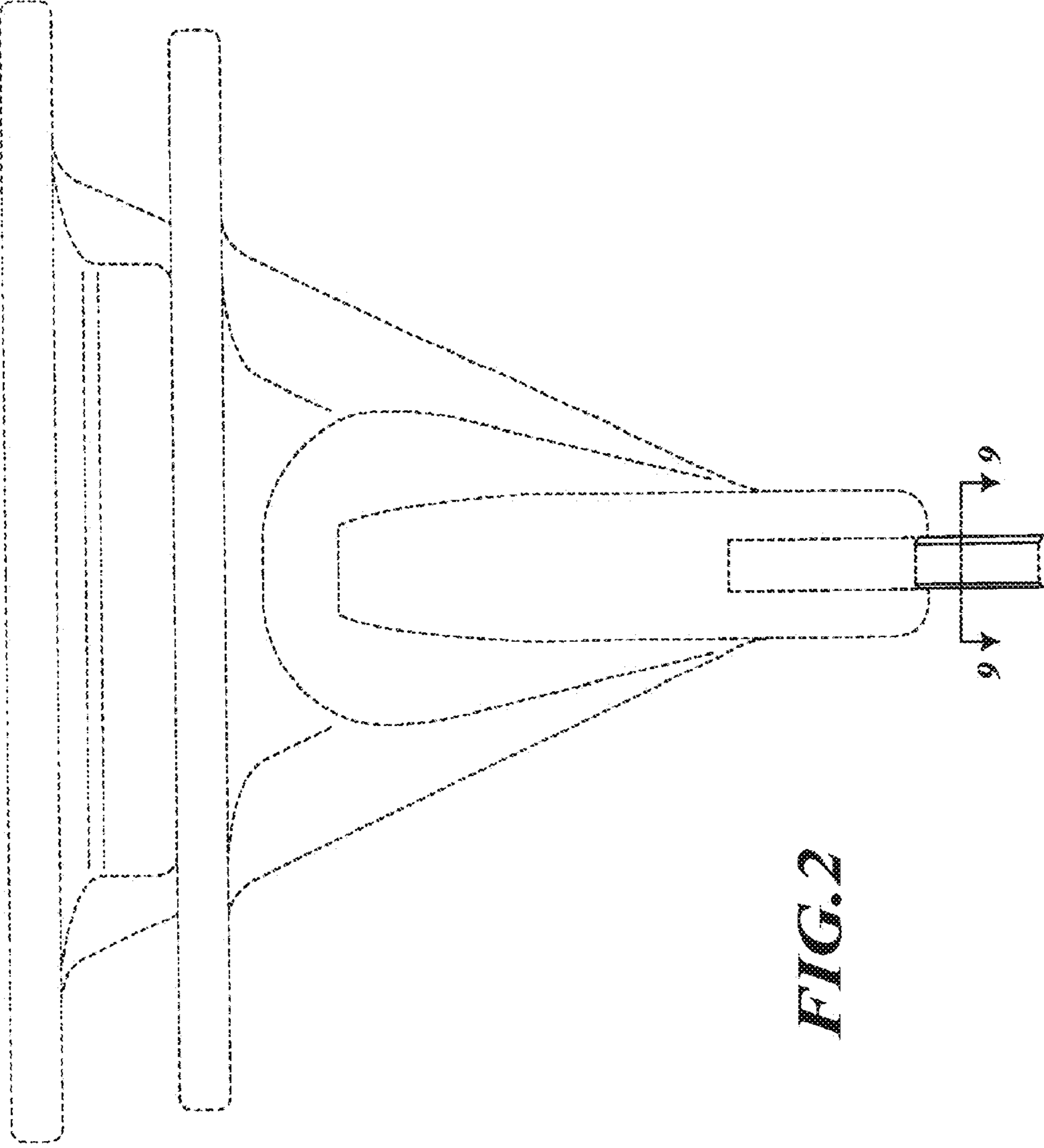

FIG. 2

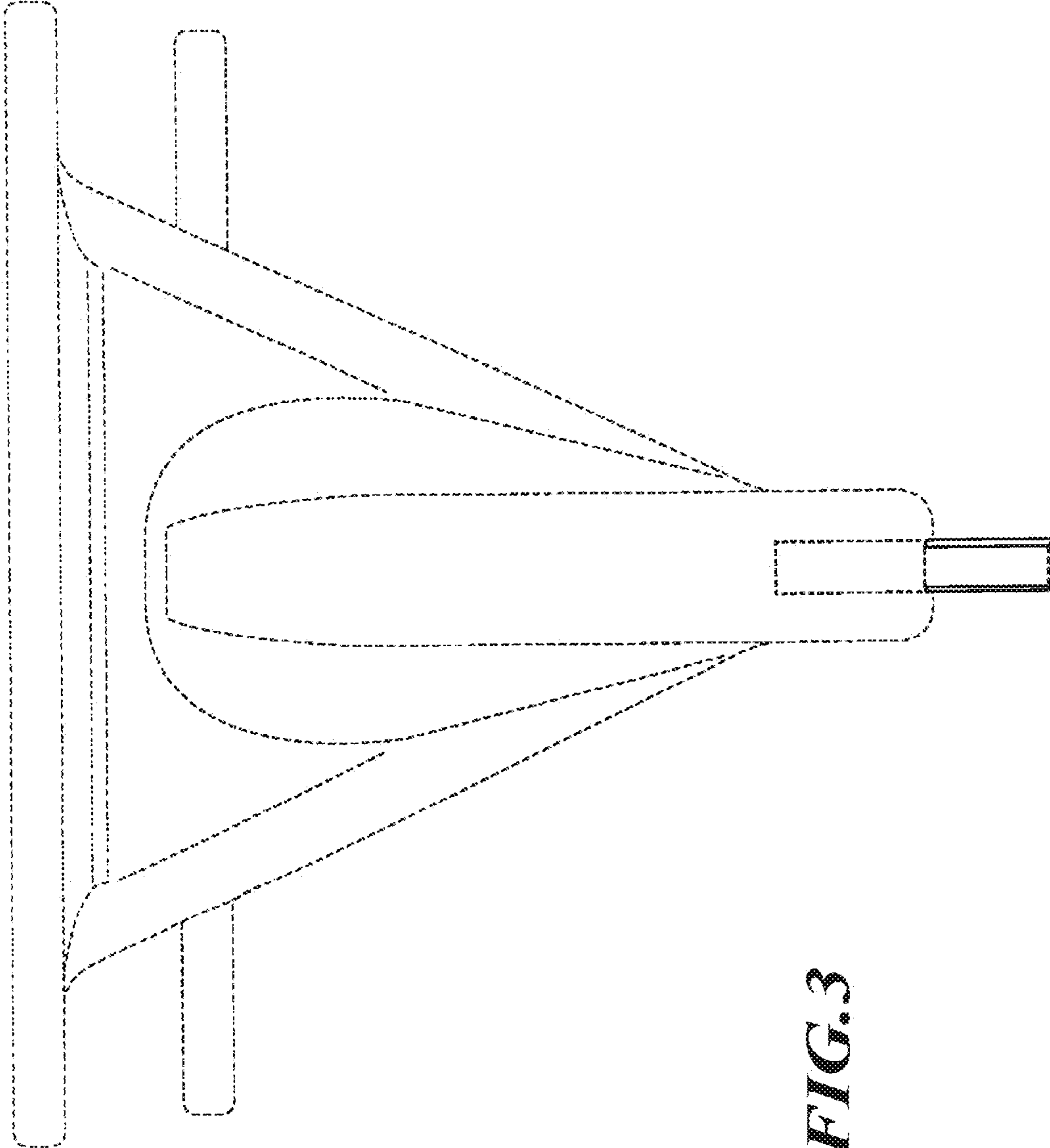

FIG. 3

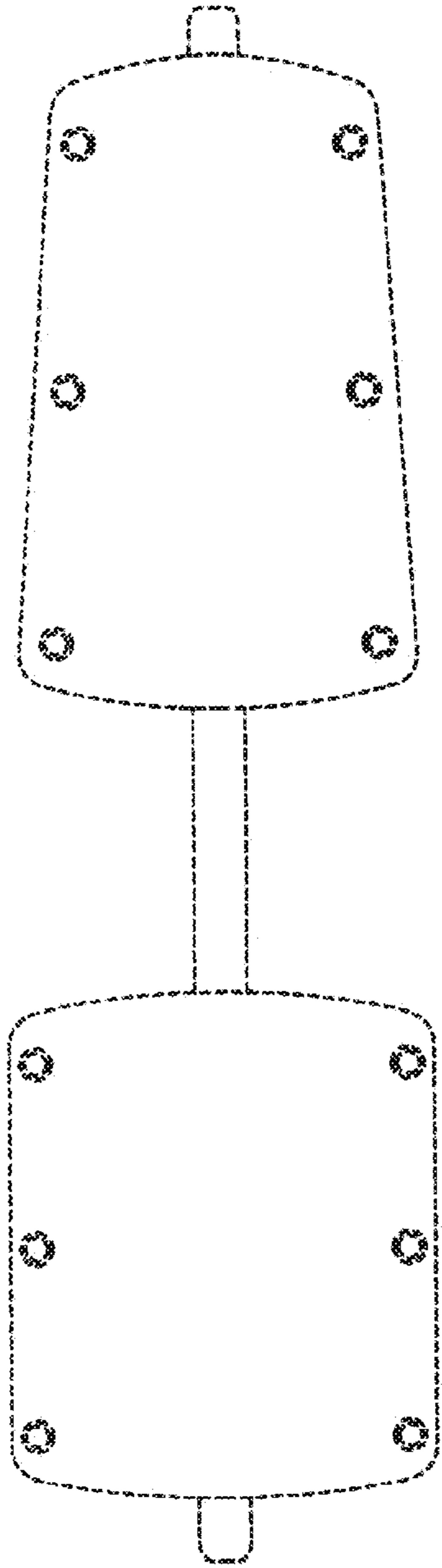

FIG. 4

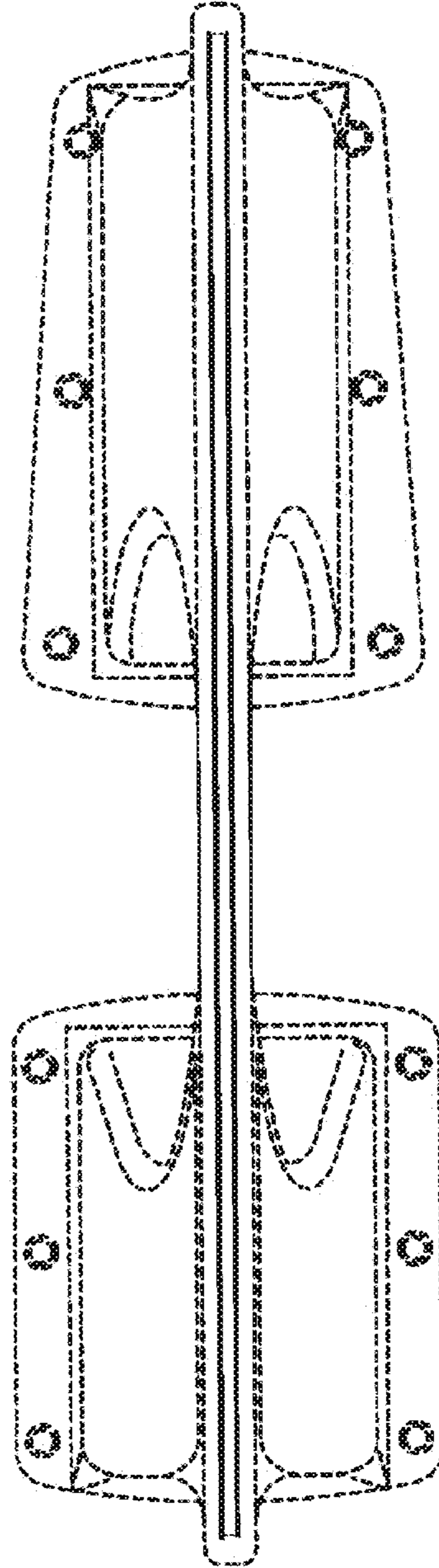

FIG. 5

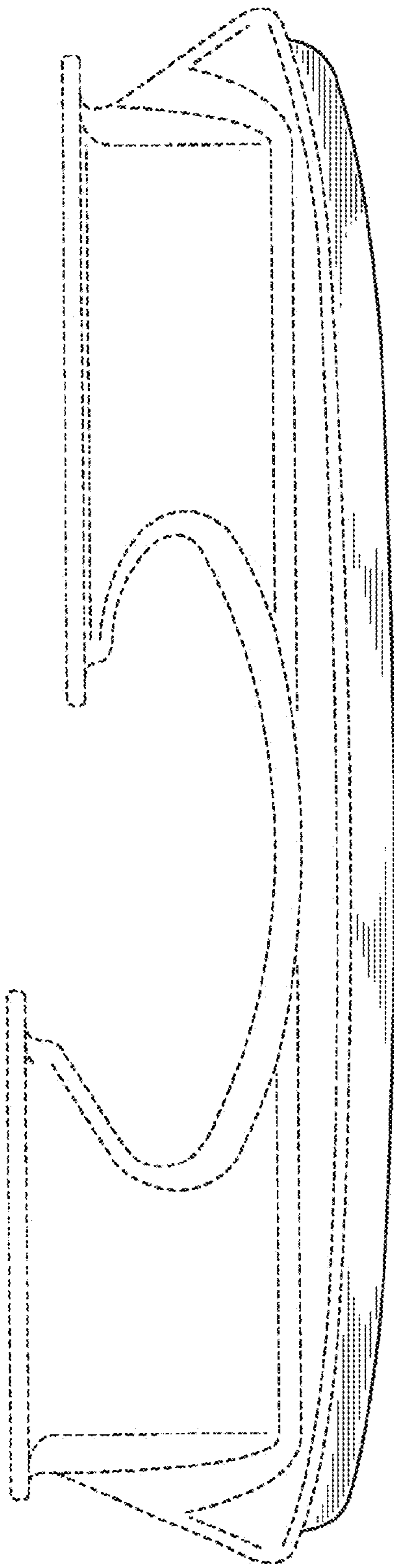

FIG. 6

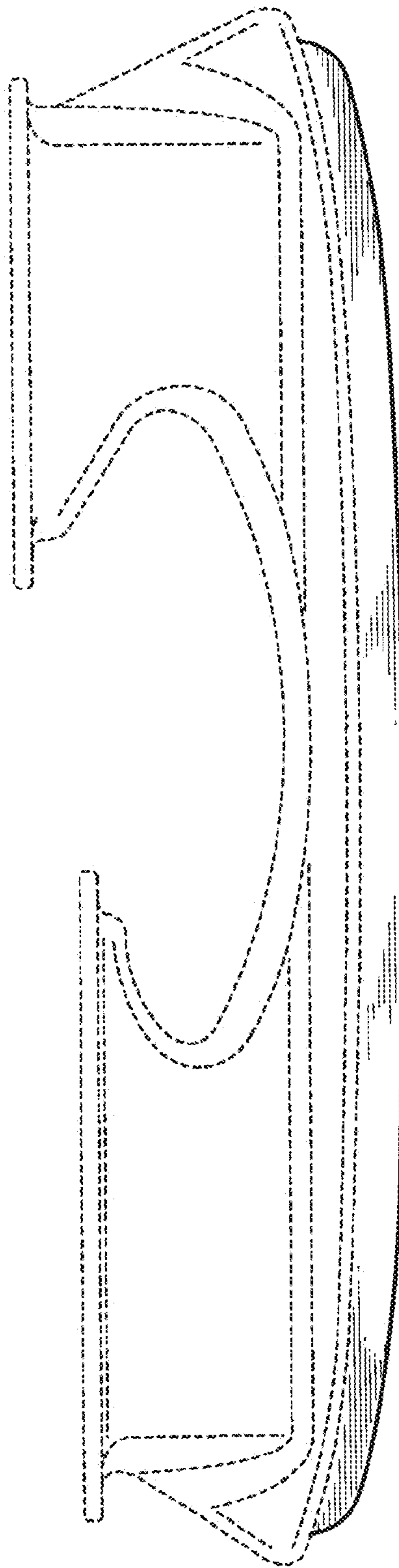

FIG. 7

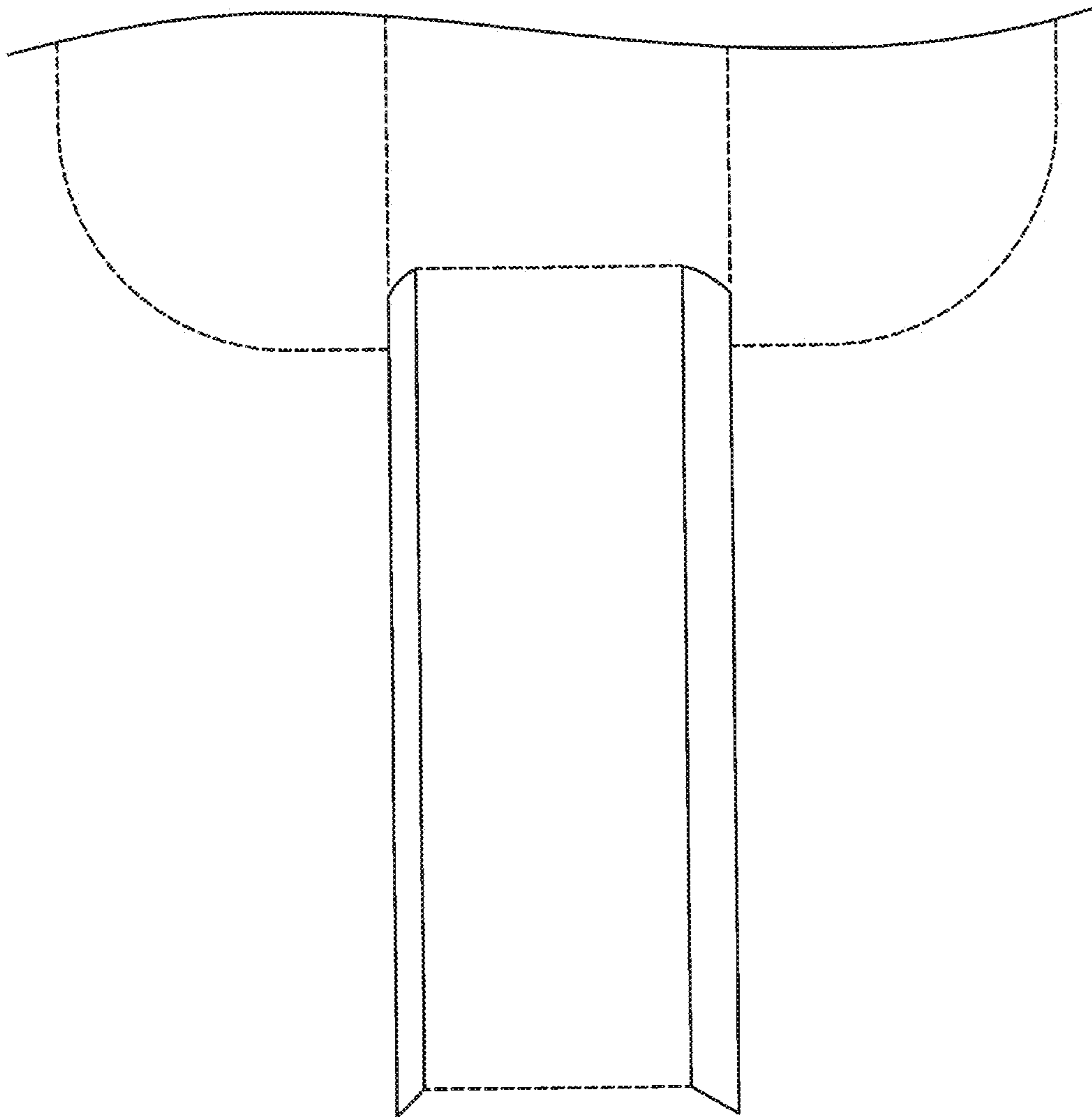

FIG. 8

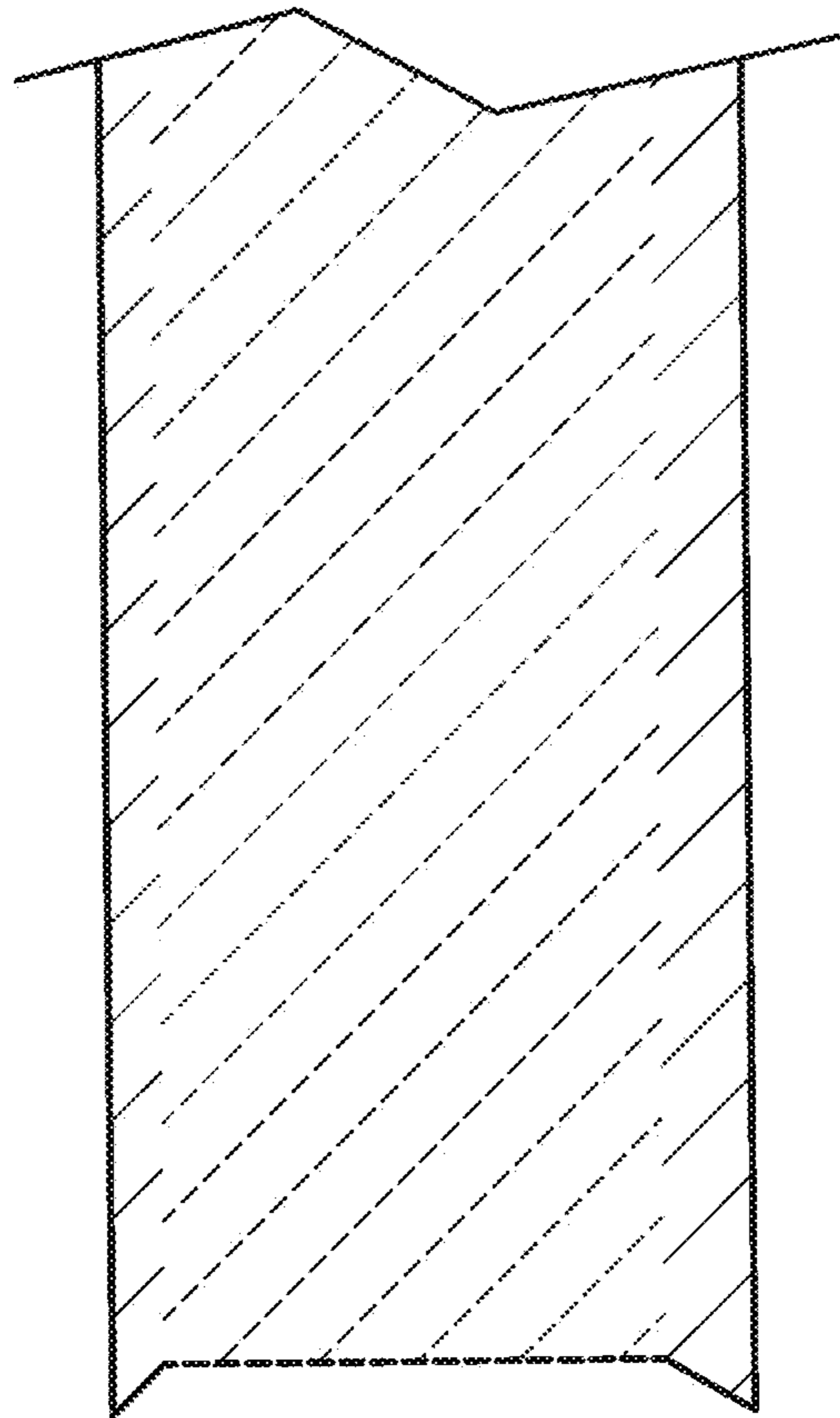

FIG. 9

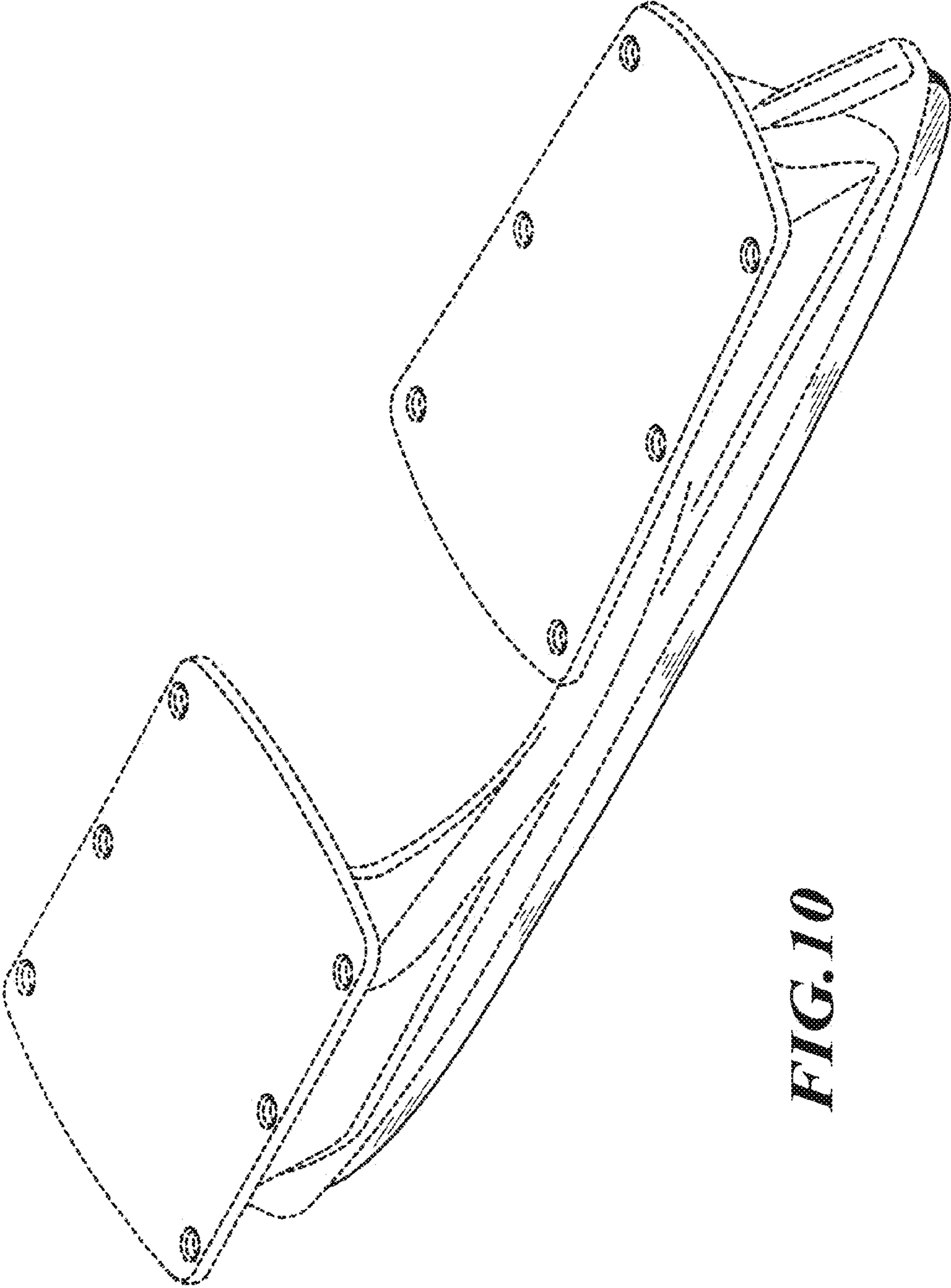

FIG. 10

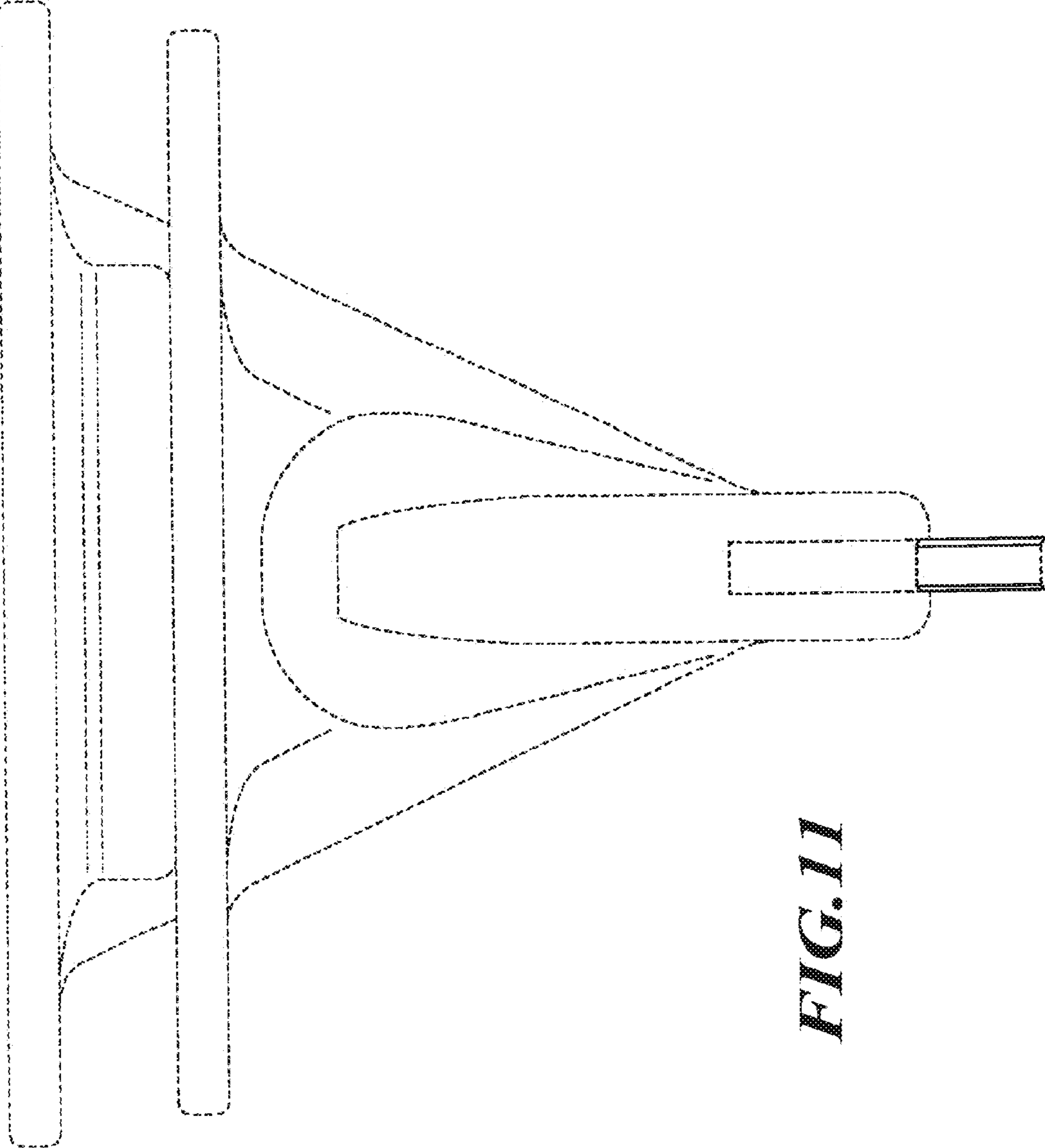

FIG. 11

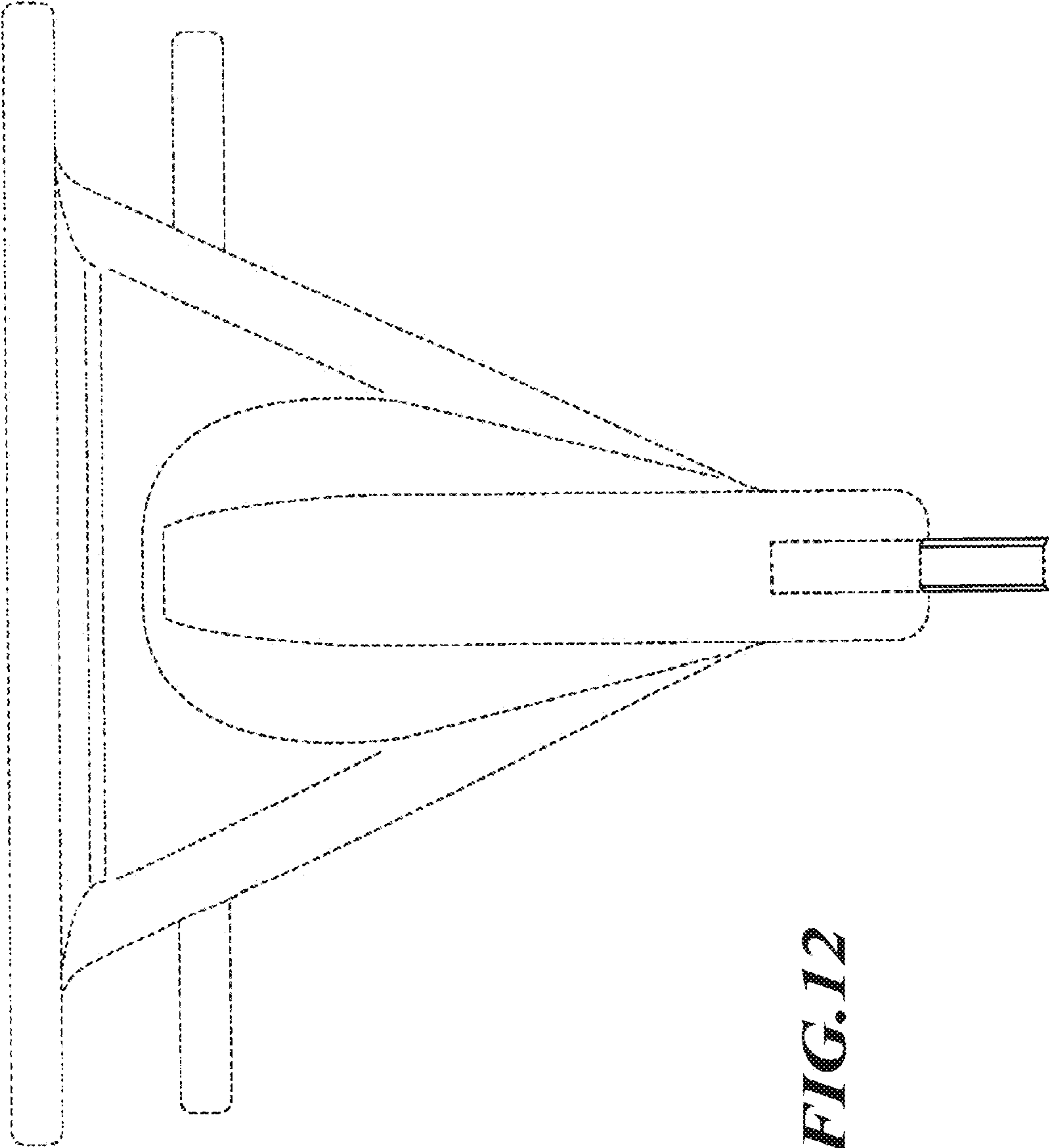

FIG. 12

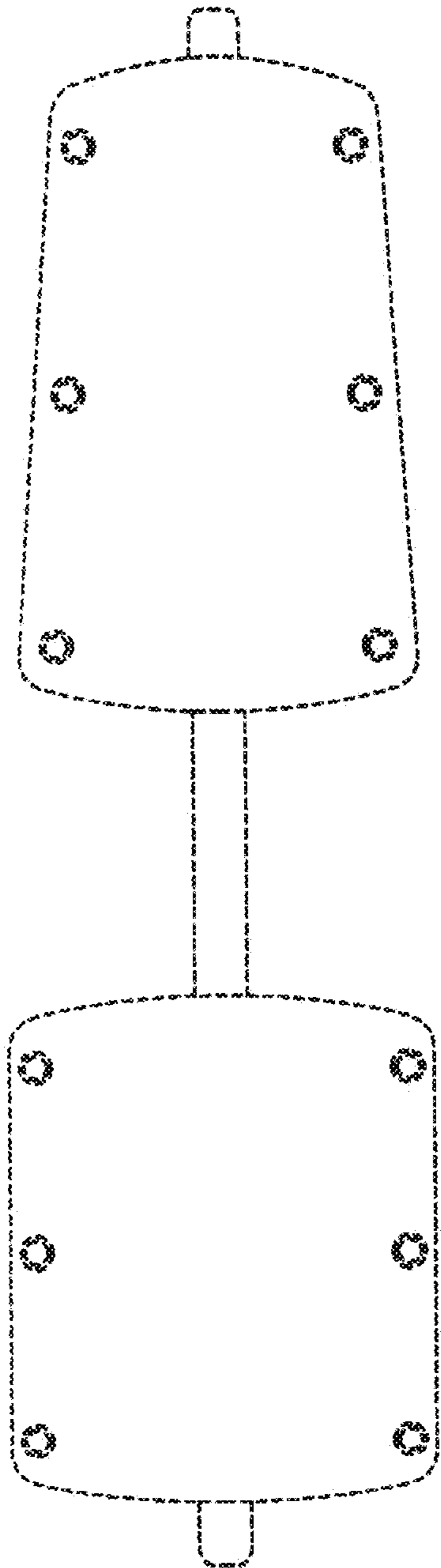

FIG. 13

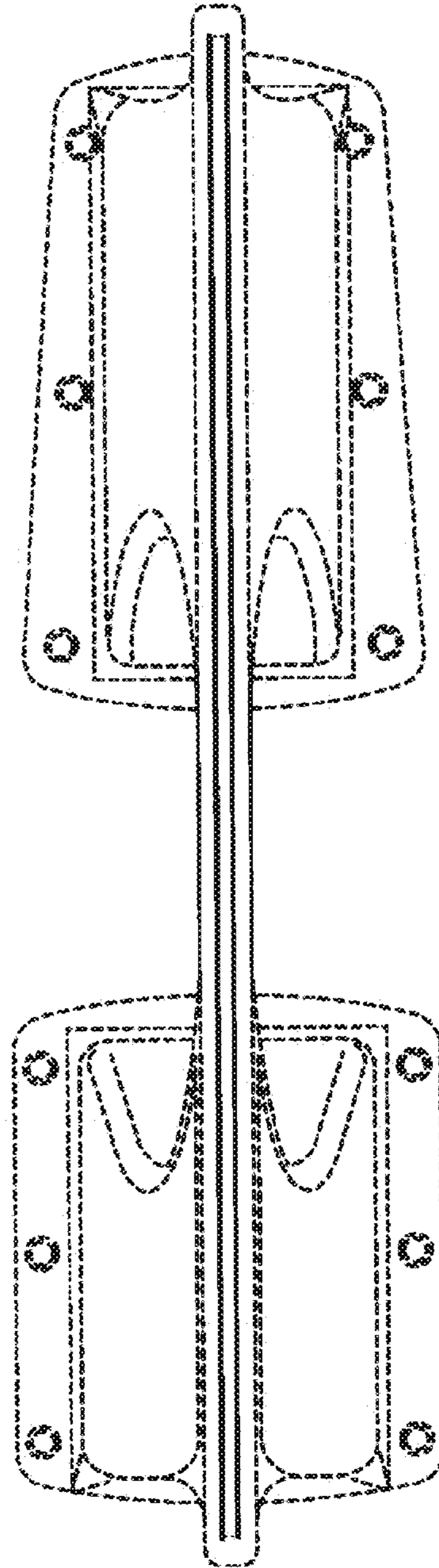

FIG. 14

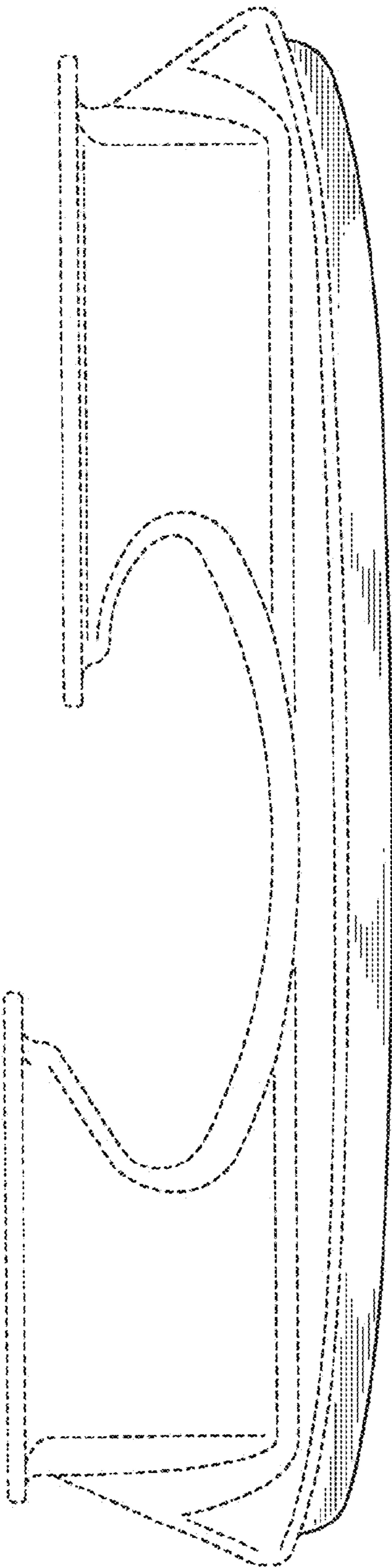

FIG. 15

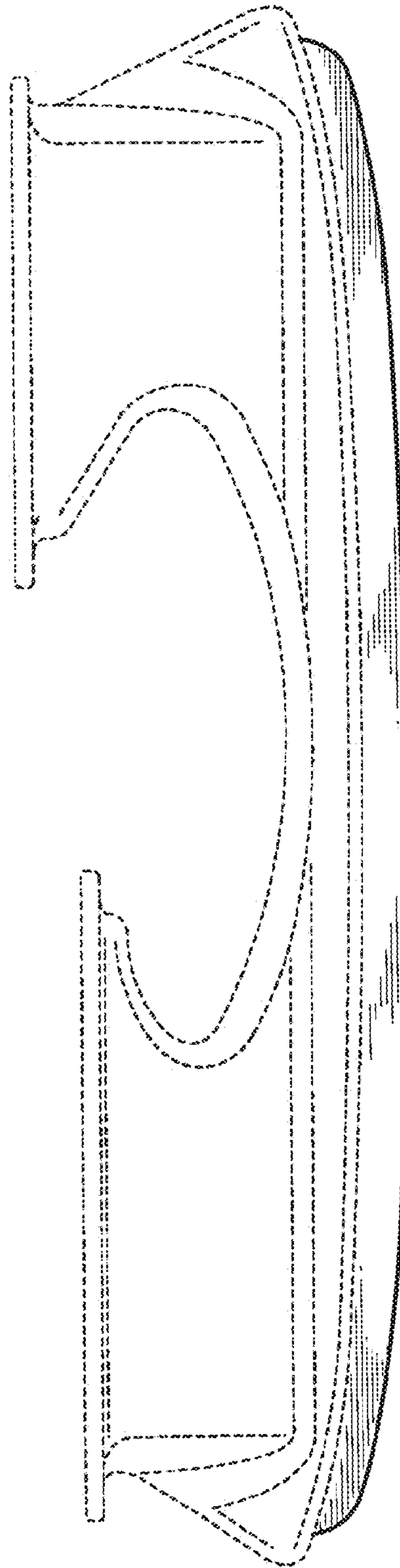

FIG. 16

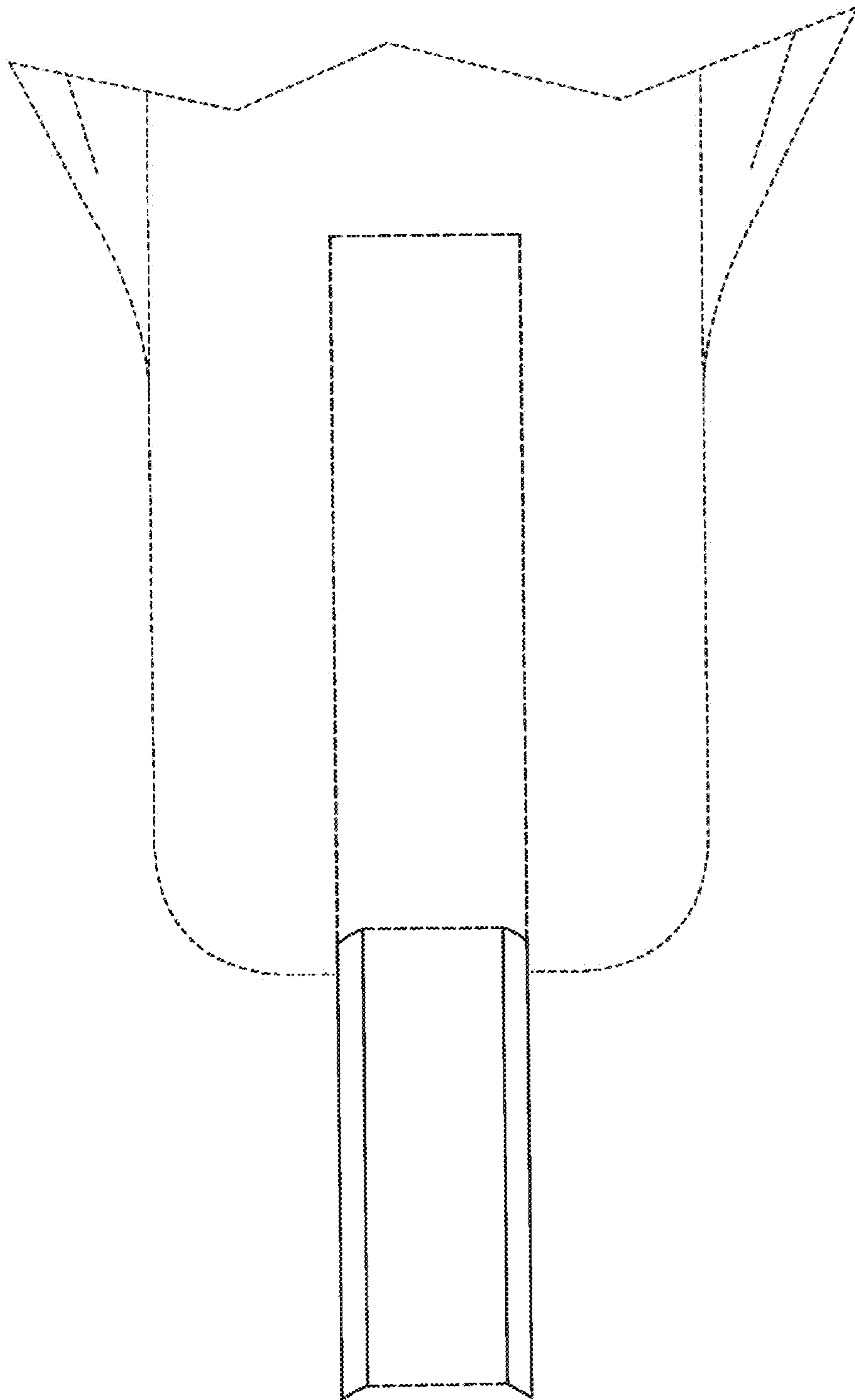

FIG. 17