



US00D766218S

(12) **United States Design Patent**
Yang et al.

(10) **Patent No.:** **US D766,218 S**
(45) **Date of Patent:** **** Sep. 13, 2016**

(54) **REMOTE CONTROL**

(71) Applicant: **Analogix Semiconductor, Inc.**, Santa Clara, CA (US)

(72) Inventors: **Kewei Yang**, Saratoga, CA (US);
André Bouwer, San Jose, CA (US);
Marvin Su, Palo Alto, CA (US);
Soumendra Mohanty, San Jose, CA (US)

(73) Assignee: **Analogix Semiconductor, Inc.**, Santa Clara, CA (US)

(**) Term: **14 Years**

(21) Appl. No.: **29/525,448**

(22) Filed: **Apr. 29, 2015**

Related U.S. Application Data

(63) Continuation-in-part of application No. 14/624,521, filed on Feb. 17, 2015.

(51) **LOC (10) Cl.** **14-03**

(52) **U.S. Cl.**
USPC **D14/218**

(58) **Field of Classification Search**

USPC D14/137, 174, 217-218, 240, 247,
D14/388-390, 396, 511, 485, 489, 490, 491,
D14/492; D21/516; D13/162-164, 168,
D13/174; 715/738; 434/350; 600/323;
348/211.99, 14.05, 114, 734;
341/175-176; 455/575.1
CPC G08C 23/04; G08C 19/12; H04N 5/44;
H04L 17/02

See application file for complete search history.

(56) **References Cited**

U.S. PATENT DOCUMENTS

D533,177 S * 12/2006 Andre D14/314
D537,817 S * 3/2007 Andre D14/314

FOREIGN PATENT DOCUMENTS

CN 303454038 11/2015
CN 303542283 1/2016
WO DM088070 10/2015

OTHER PUBLICATIONS

Notice of Allowance dated Aug. 25, 2015 in Chinese Application No. 201530187861.0, filed Jun. 10, 2015.

Notice of Allowance dated Oct. 15, 2015 in Chinese Application No. 201530187611.7, filed Jun. 10, 2015.

Non-Final Office Action, Sep. 24, 2015, U.S. Appl. No. 14/624,521, filed Feb. 17, 2015.

Non-Final Office Action, Dec. 2, 2015, U.S. Appl. No. 14/734,950, filed Jun. 9, 2015.

Office Action dated Mar. 10, 2016 in Taiwanese Application No. 104306033, filed Oct. 27, 2015.

* cited by examiner

Primary Examiner — Ralf Seifert

(74) *Attorney, Agent, or Firm* — Carr & Ferrell LLP

(57) **CLAIM**

The ornamental design for a remote control, as shown and described.

DESCRIPTION

FIG. 1 is a top perspective view of a remote control showing our new design;

FIG. 2 is a sectional view taken along the lines in FIG. 1;

FIG. 3 is another perspective view of FIG. 1;

FIG. 4 is a sectional view taken along the lines in FIG. 3;

FIG. 5 is a front view of FIG. 1;

FIG. 6 is a rear view of FIG. 1;

FIG. 7 is a right side view of FIG. 1;

FIG. 8 is a left side view of FIG. 1;

FIG. 9 is a top view of FIG. 1;

FIG. 10 is a bottom view of FIG. 1;

FIG. 11 is a top perspective view of a remote control showing the second embodiment of our new design;

FIG. 12 is a sectional view taken along the lines in FIG. 11;

FIG. 13 is another top perspective view of FIG. 11;

FIG. 14 is sectional view taken along the lines in FIG. 13;

FIG. 15 is a front view of FIG. 11;

FIG. 16 is a rear view of FIG. 11;

FIG. 17 is a right side view of FIG. 11;

FIG. 18 is a left side view of FIG. 11;

FIG. 19 is a top view of FIG. 11;

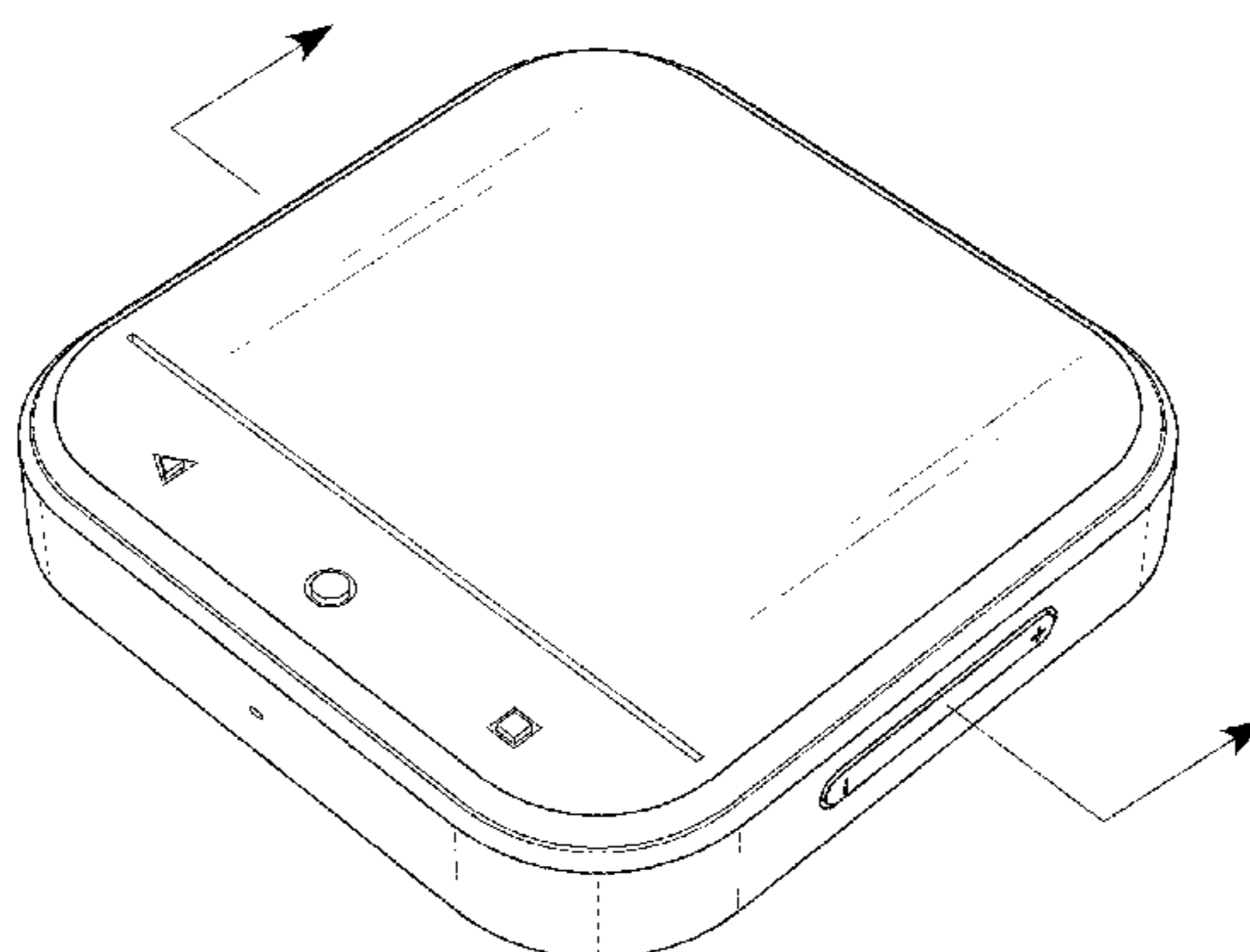

FIG. 20 is a bottom view of FIG. 11;
FIG. 21 is a top perspective view of a remote control showing the third embodiment of our new design;
FIG. 22 is a sectional view taken along the lines in FIG. 21;
FIG. 23 is another top perspective view of FIG. 21;
FIG. 24 is a sectional view taken along the lines in FIG. 23;
FIG. 25 is a front view of FIG. 21;
FIG. 26 is a rear view of FIG. 21;
FIG. 27 is a right side view of FIG. 21;
FIG. 28 is a left side view of FIG. 21;
FIG. 29 is a top view of FIG. 21;
FIG. 30 is a bottom view of FIG. 21;
FIG. 31 is a top perspective view of a remote control showing the fourth embodiment of our new design;
FIG. 32 is a sectional view taken along the lines in FIG. 31;
FIG. 33 is another top perspective view of FIG. 31;
FIG. 34 is a sectional view taken along the lines in FIG. 33;
FIG. 35 is a front view of FIG. 31;

FIG. 36 is a rear view of FIG. 31;
FIG. 37 is a right side view of FIG. 31;
FIG. 38 is a left side view of FIG. 31;
FIG. 39 is a top view of FIG. 31;
FIG. 40 is a bottom view of FIG. 31;
FIG. 41 is a top perspective view of a remote control showing the fifth embodiment of our new design;
FIG. 42 is a sectional view taken along the lines in FIG. 41;
FIG. 43 is another top perspective view of FIG. 41;
FIG. 44 is a sectional view taken along the lines in FIG. 43;
FIG. 45 is a front view of FIG. 41;
FIG. 46 is a rear view of FIG. 41;
FIG. 47 is a right side view of FIG. 41;
FIG. 48 is a left side view of FIG. 41;
FIG. 49 is a top view of FIG. 41; and,
FIG. 50 is a bottom view of FIG. 41.

1 Claim, 25 Drawing Sheets

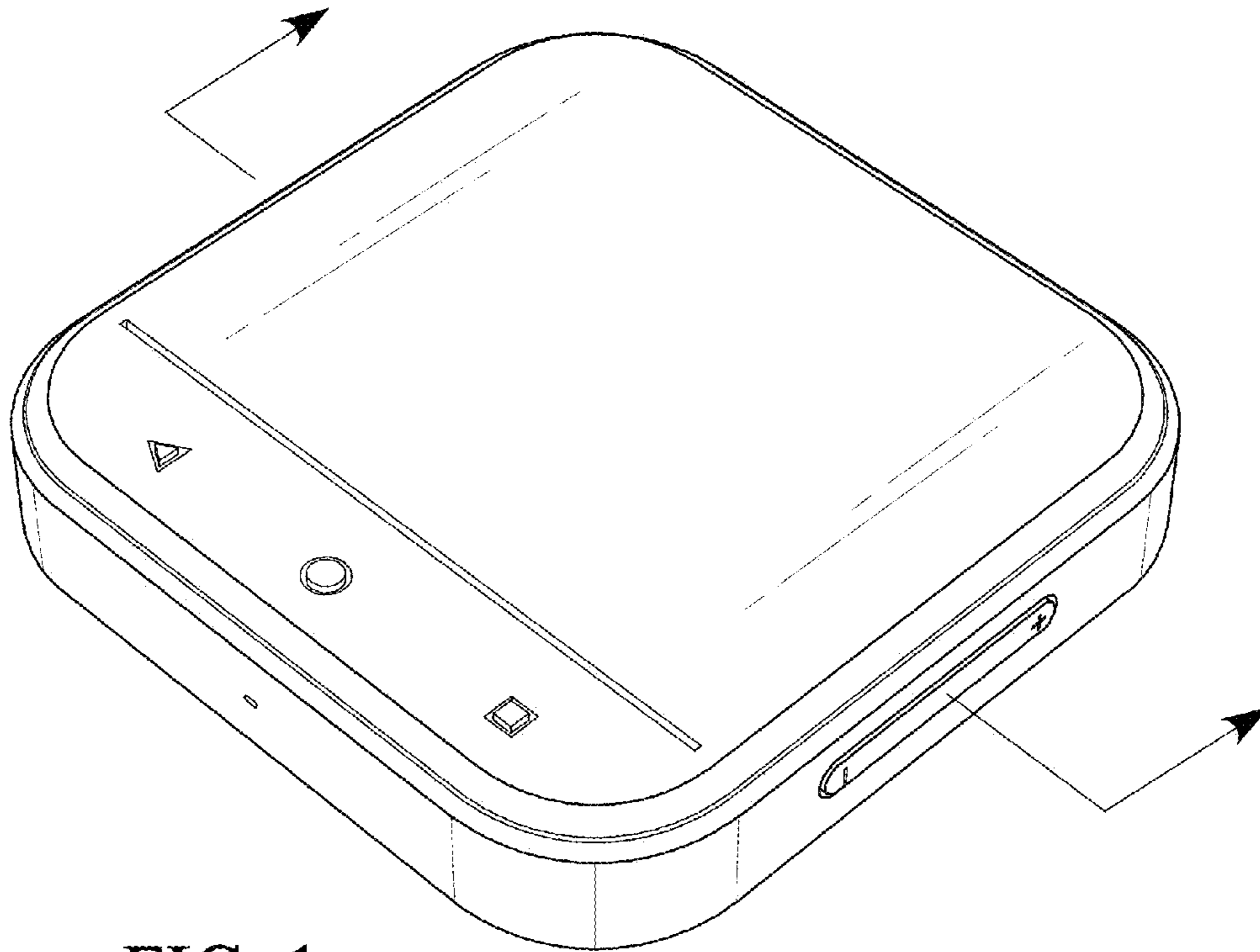

FIG. 1

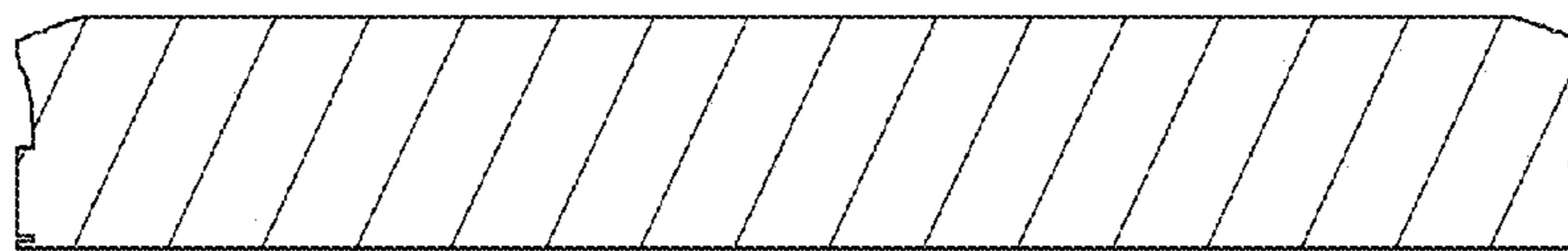
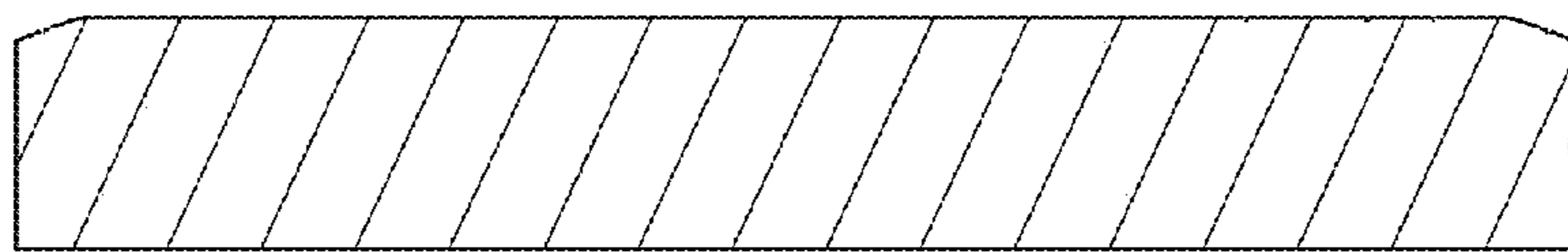
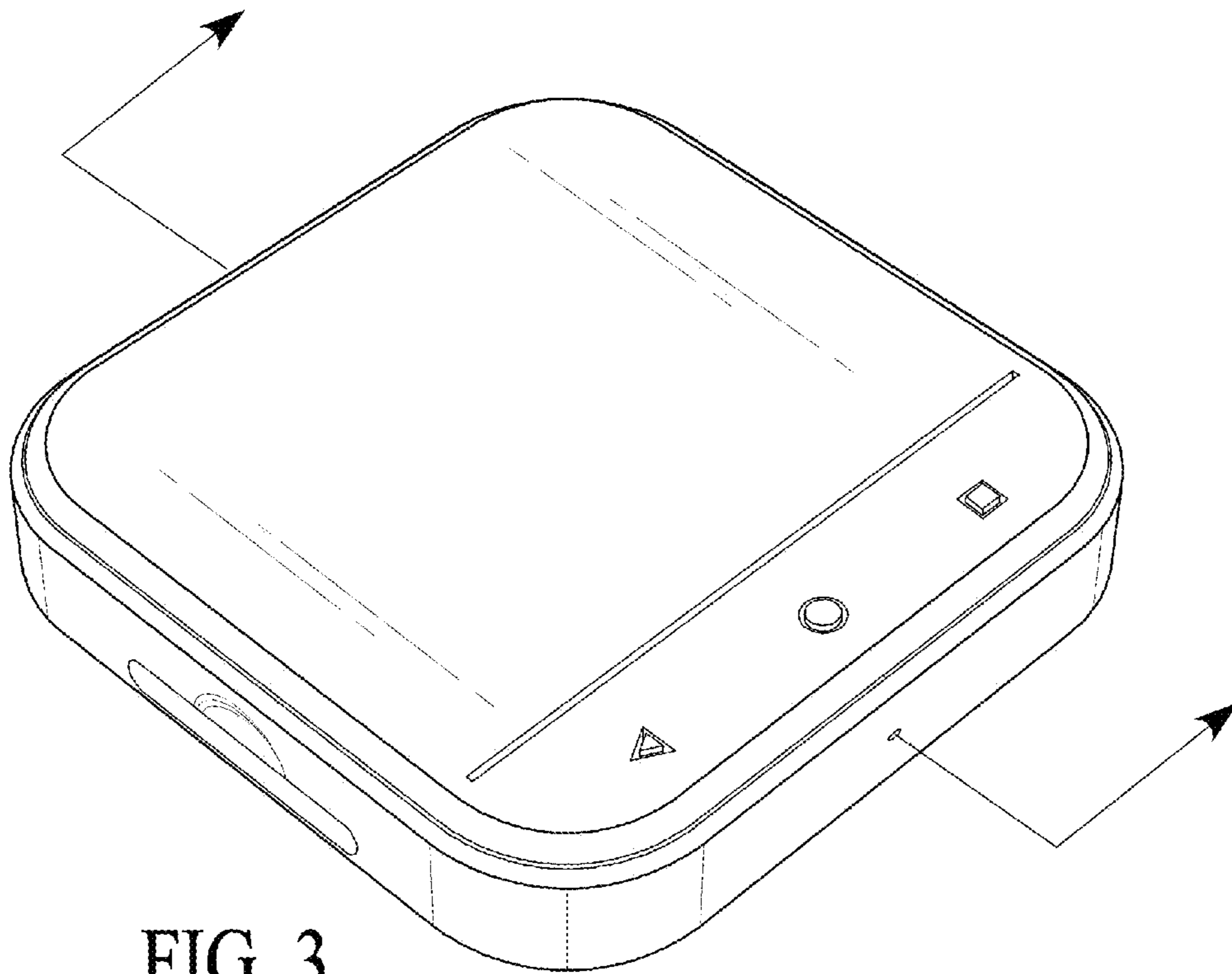

FIG. 2



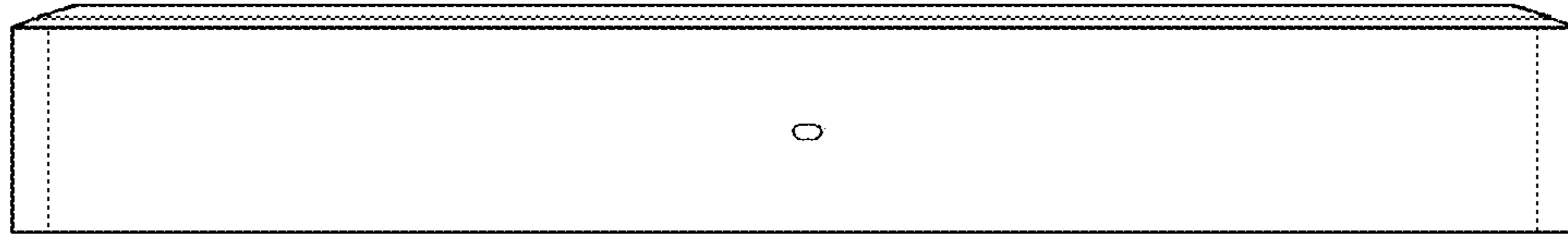

FIG. 5

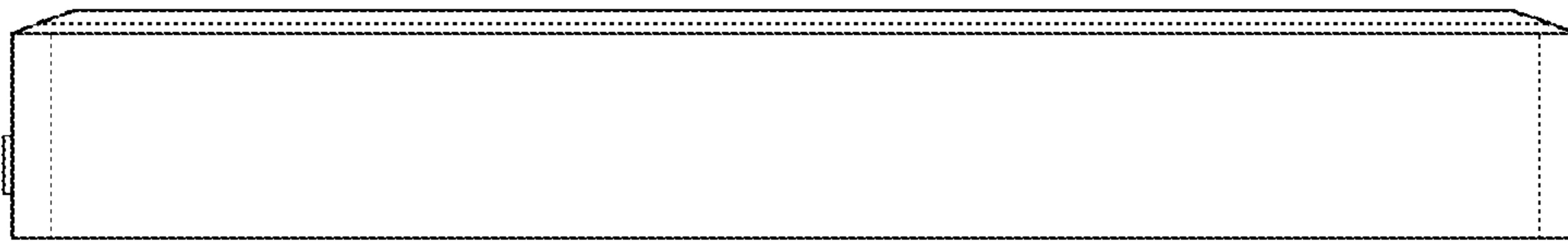

FIG. 6

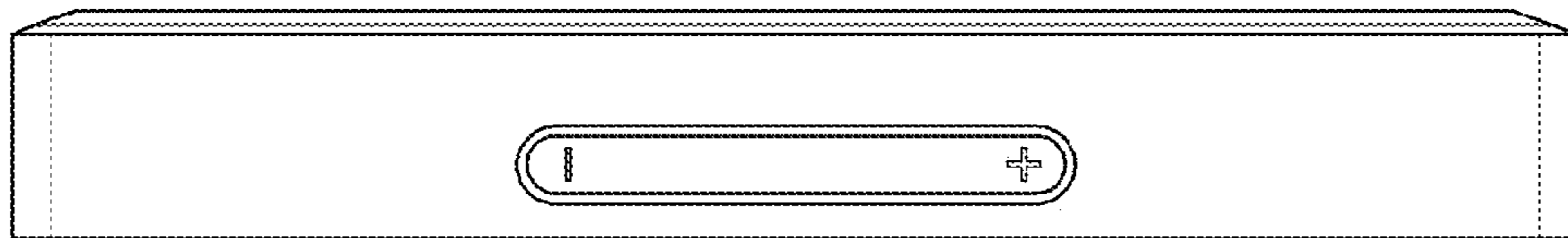

FIG. 7

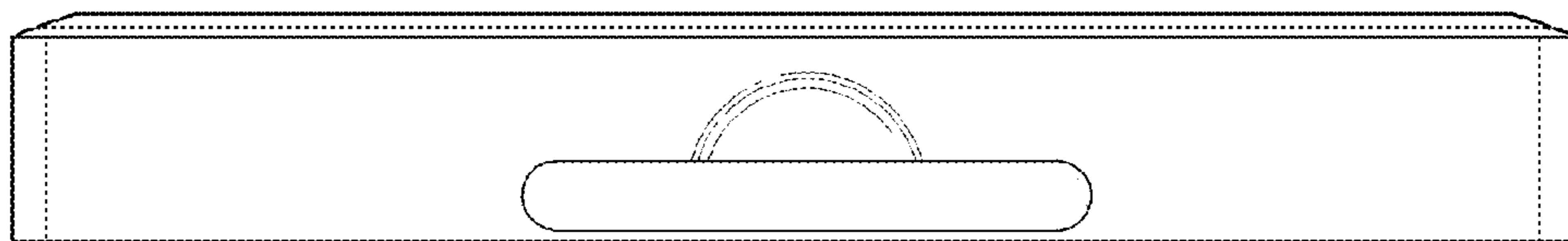

FIG. 8

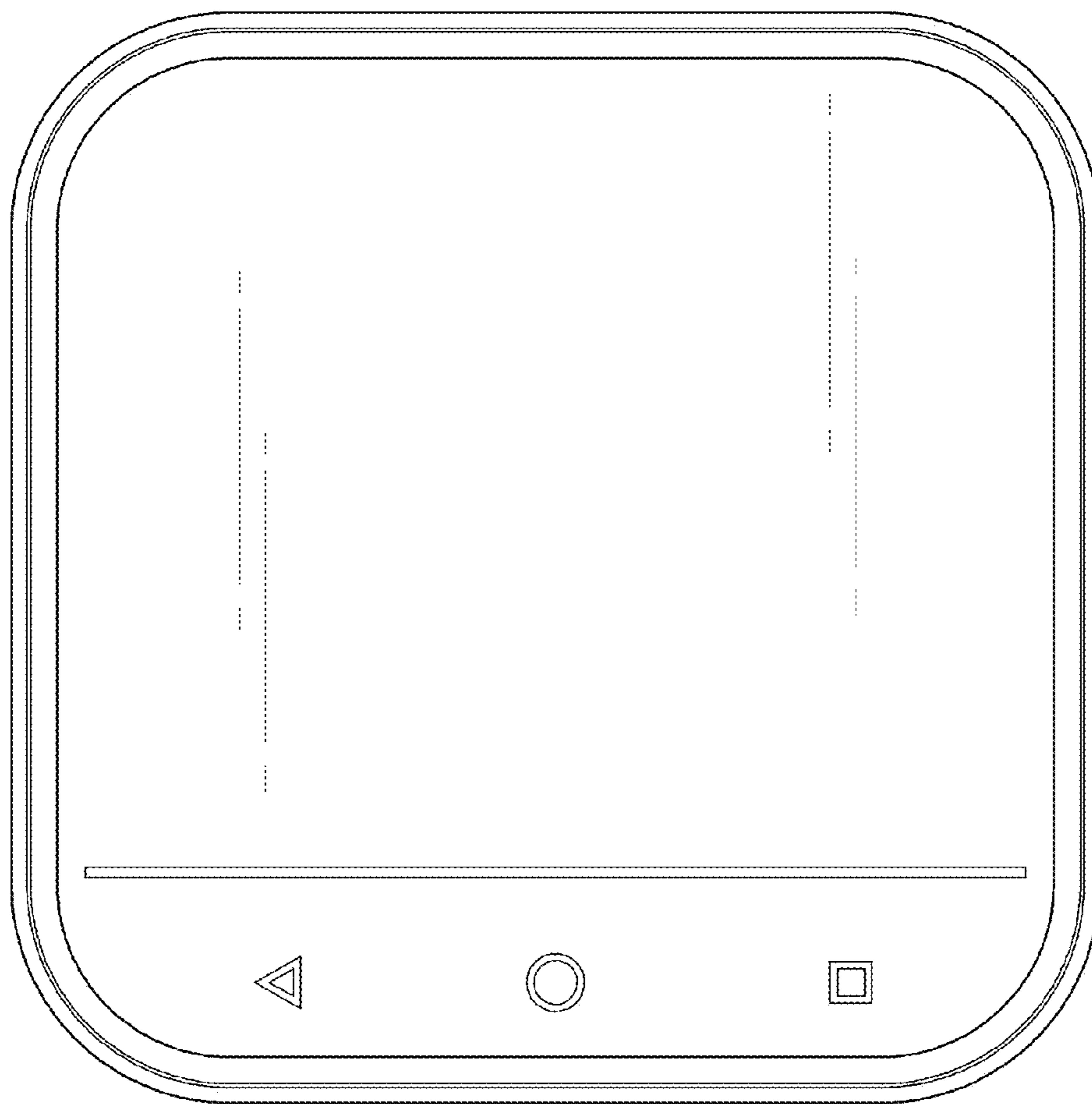

FIG. 9

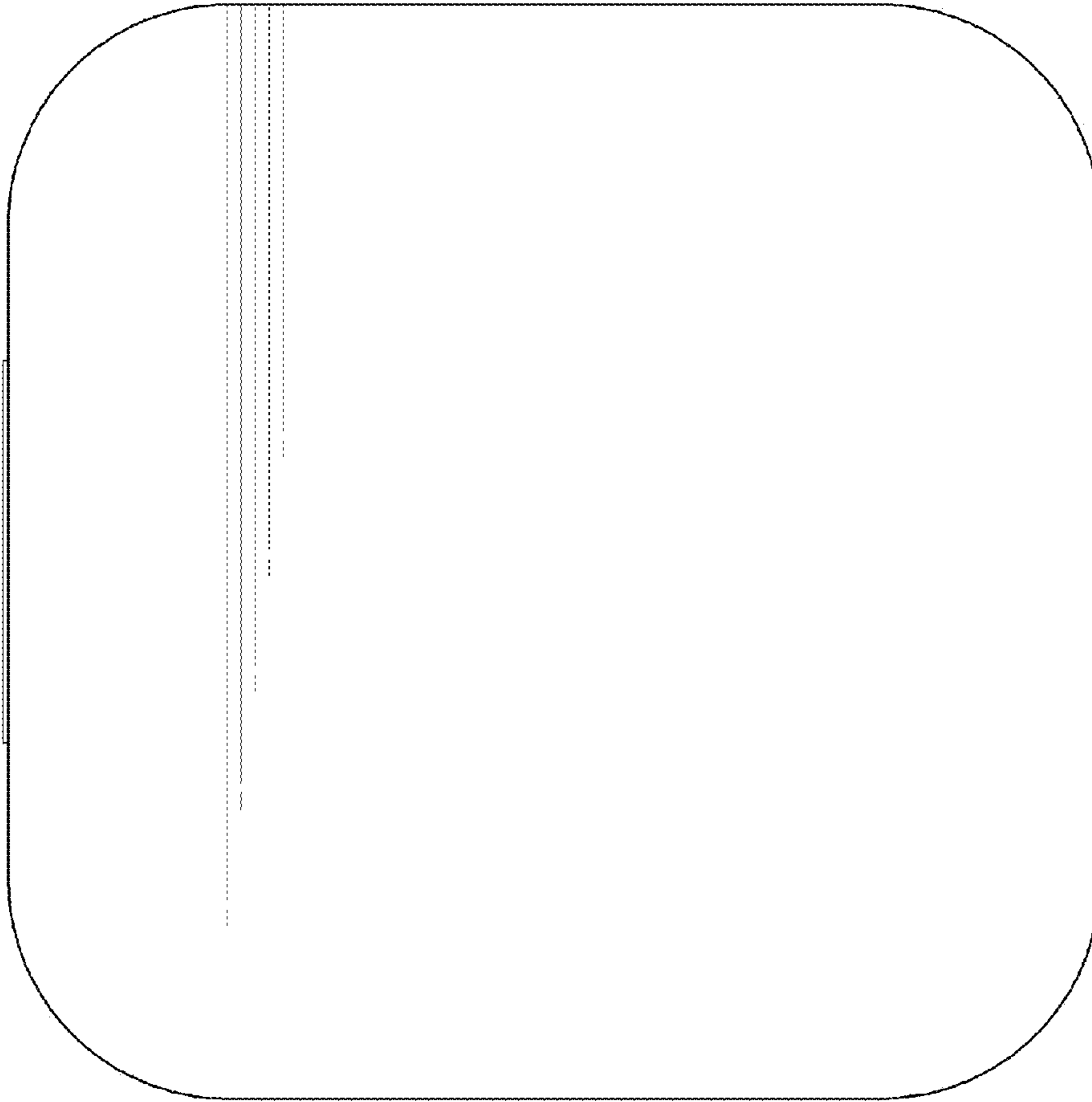

FIG. 10

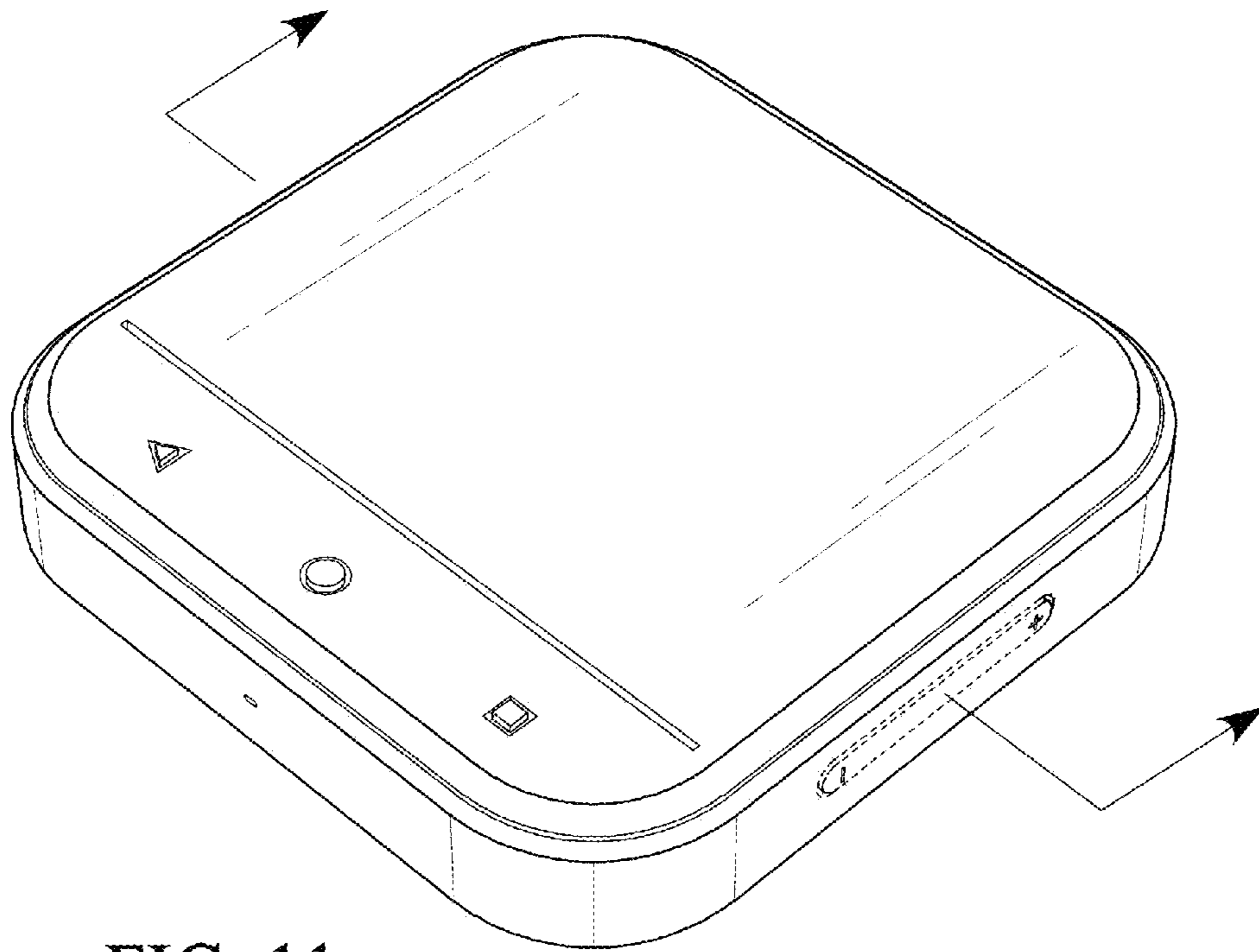

FIG. 11

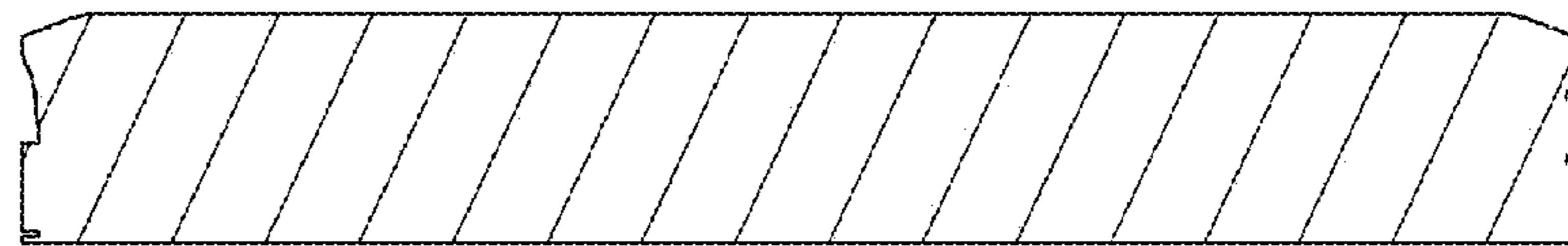

FIG. 12

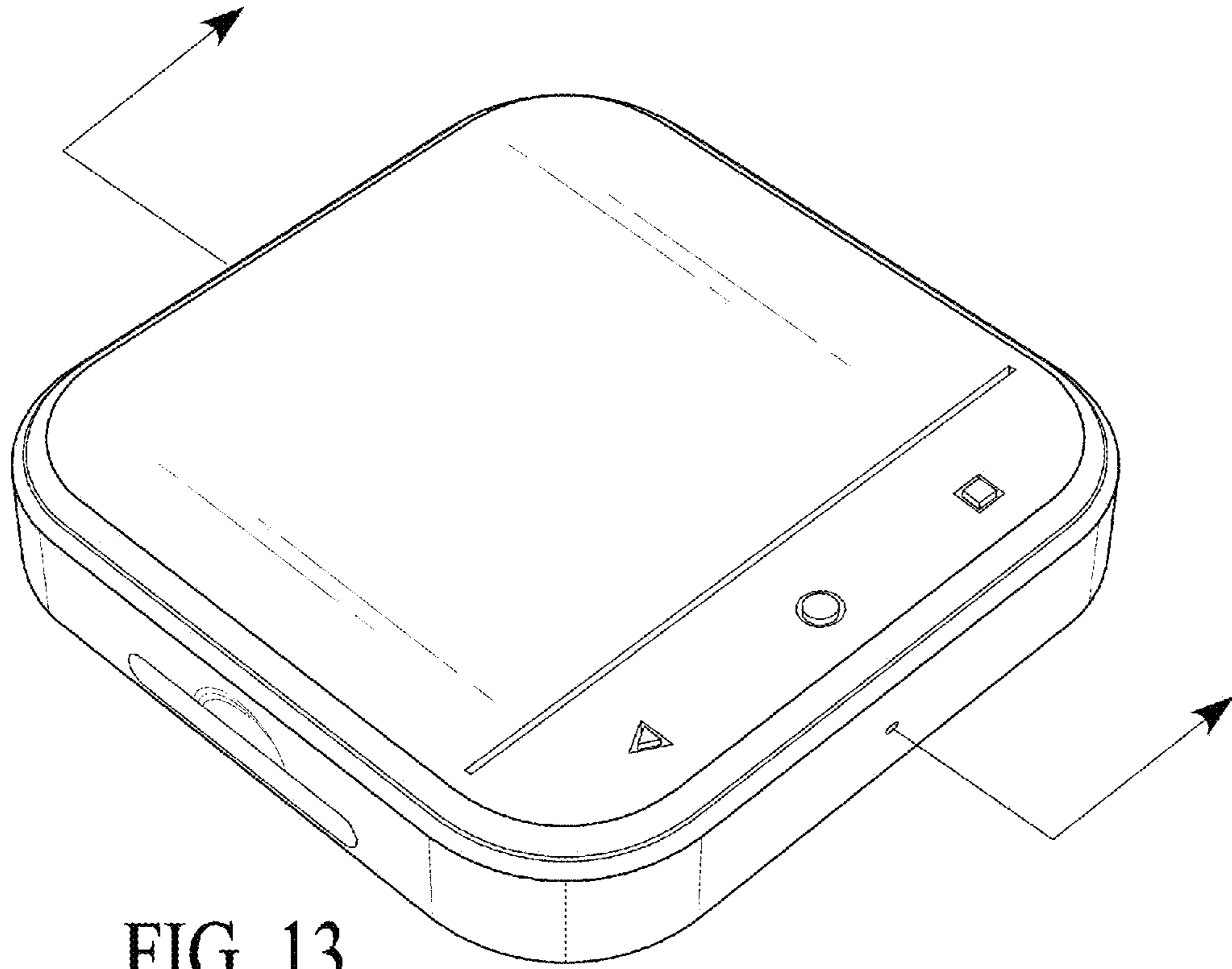

FIG. 13

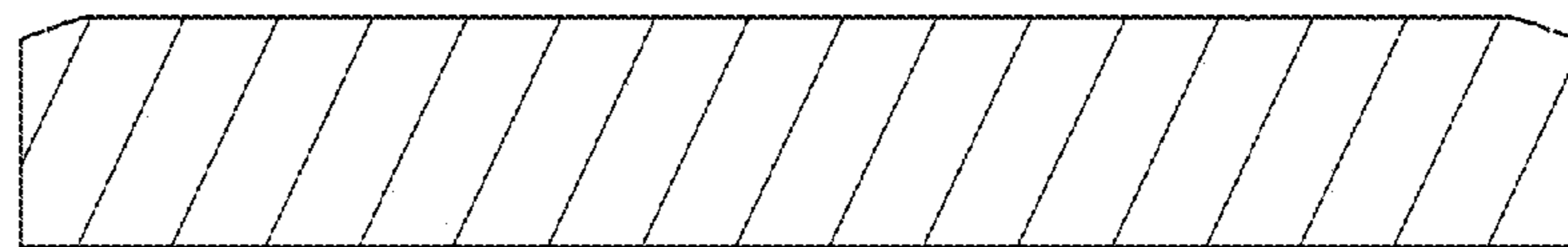

FIG. 14

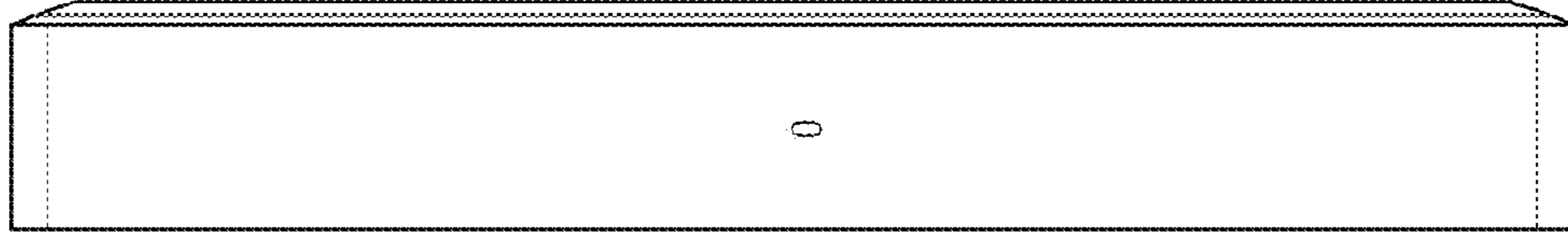

FIG. 15

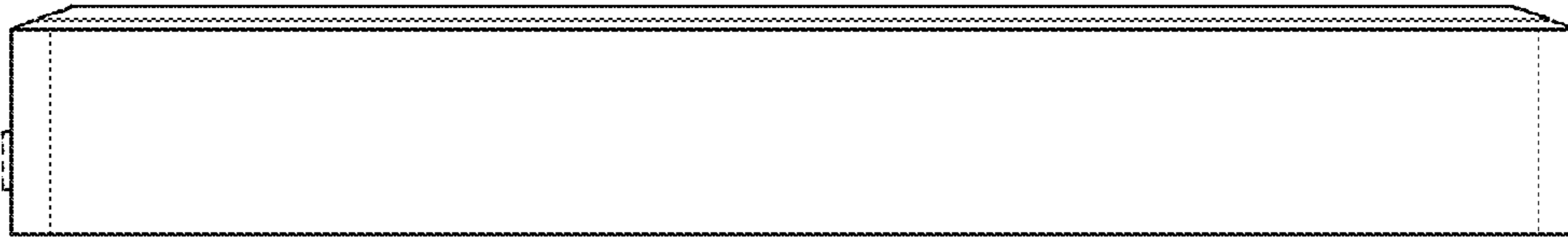

FIG. 16

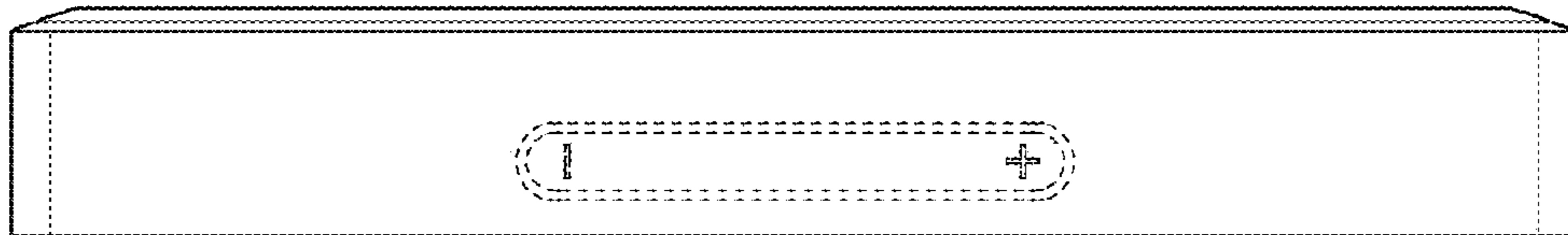

FIG. 17

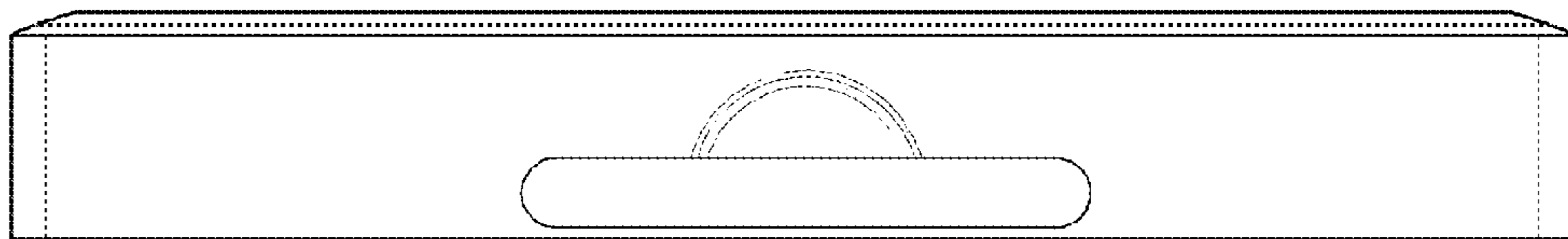

FIG. 18

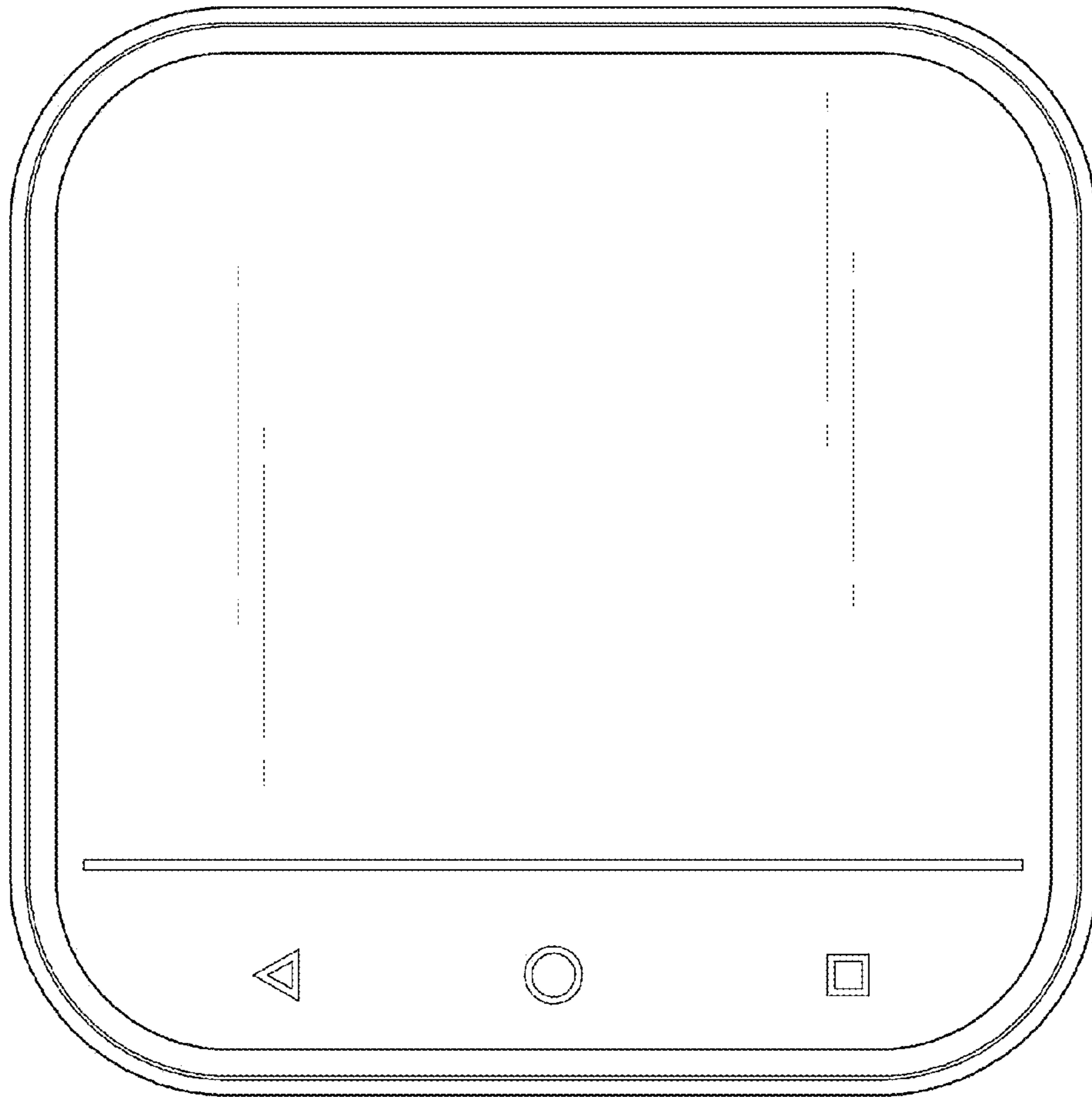

FIG. 19

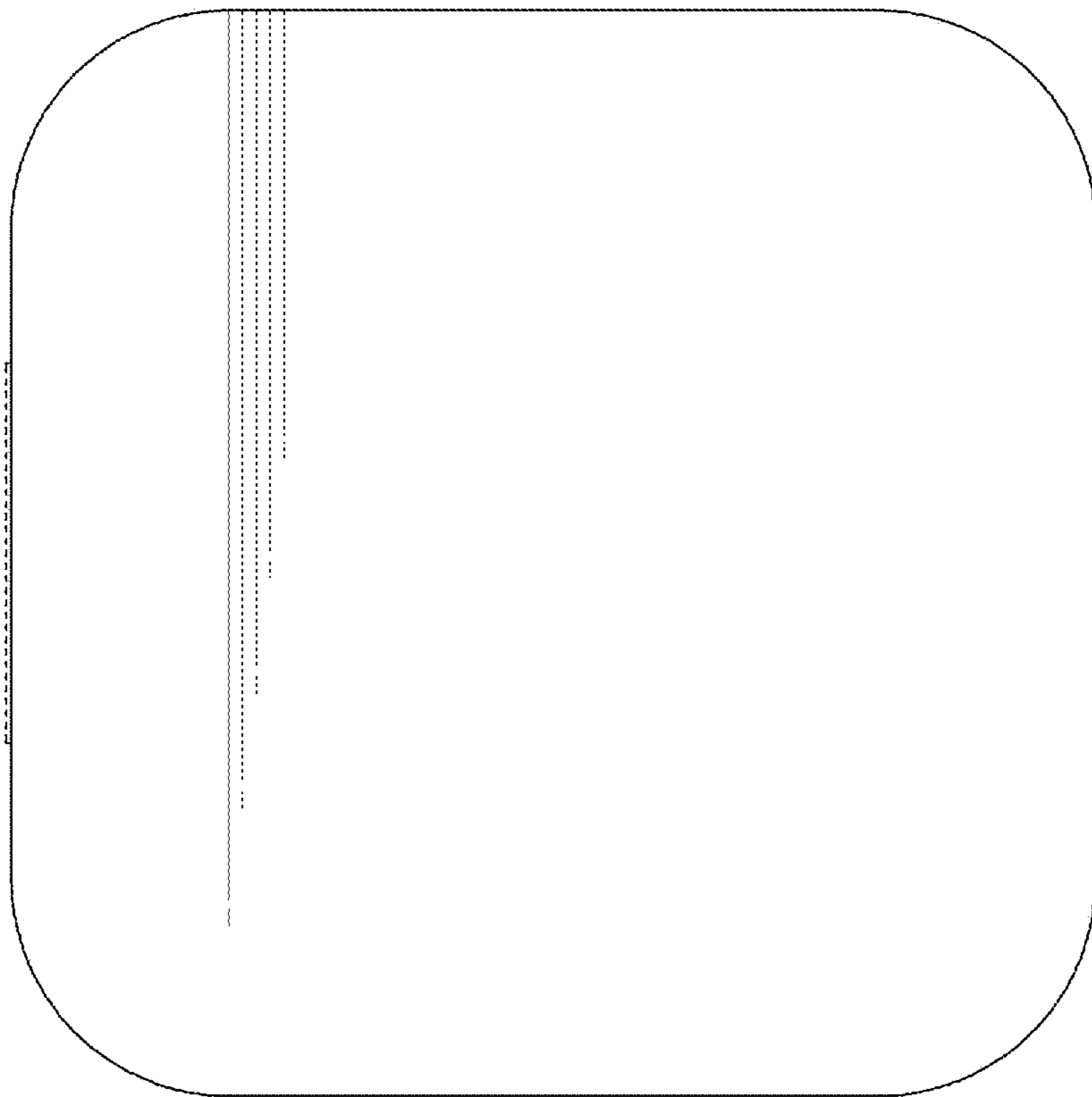

FIG. 20

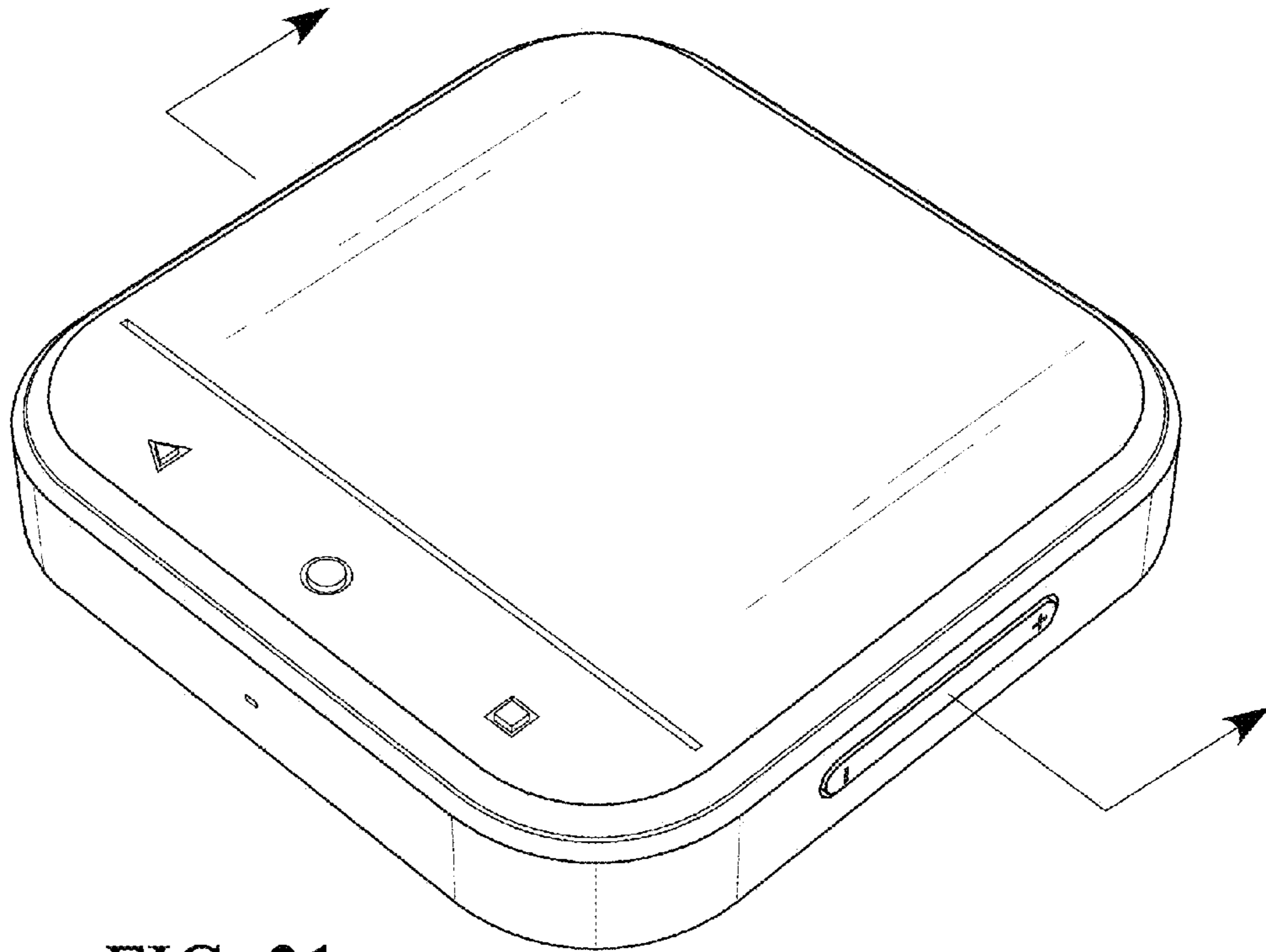

FIG. 21

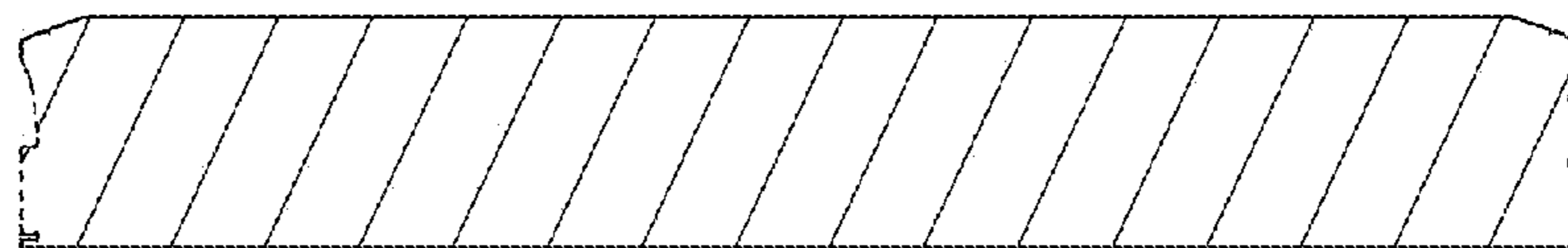

FIG. 22

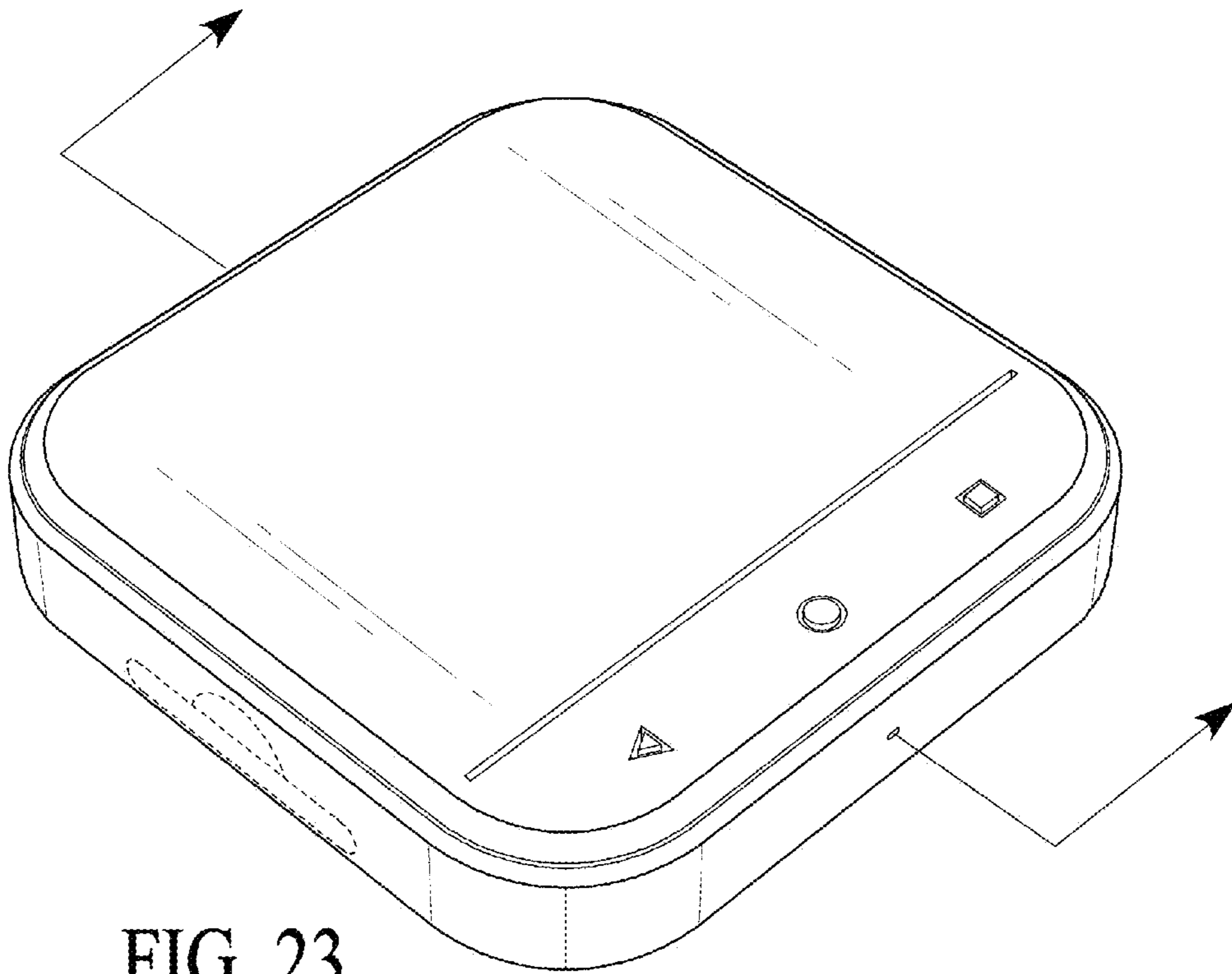

FIG. 23

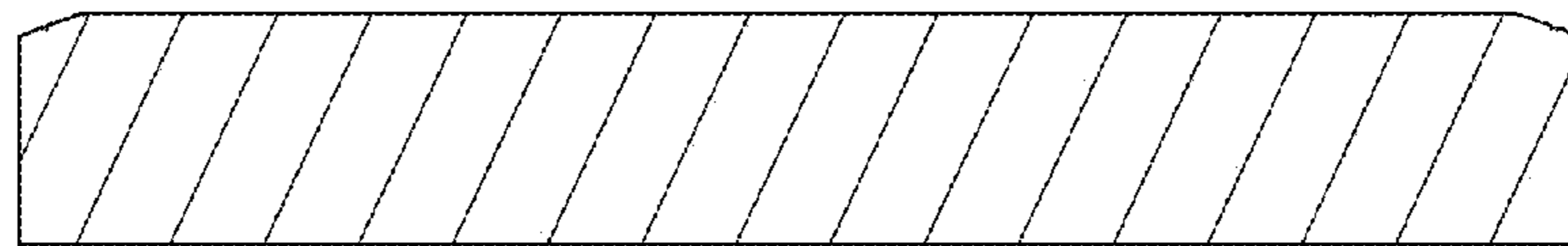

FIG. 24

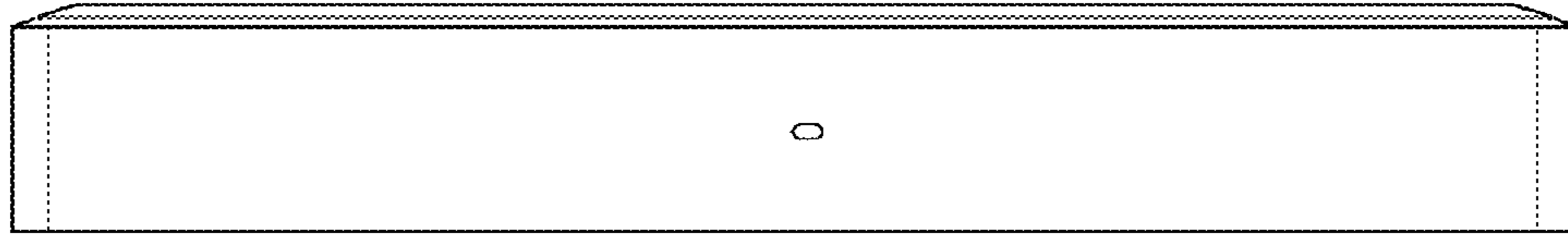

FIG. 25



FIG. 26

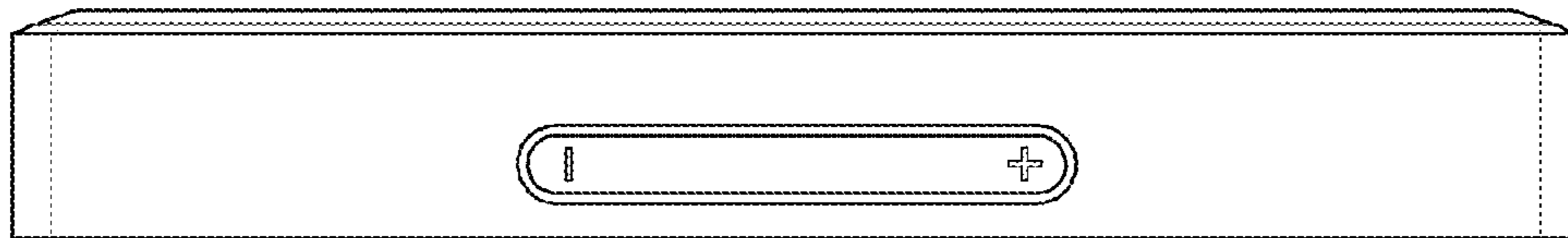

FIG. 27

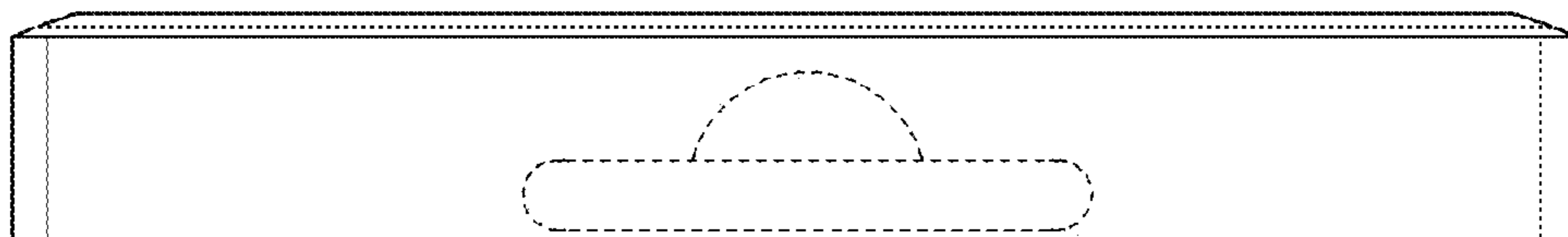

FIG. 28

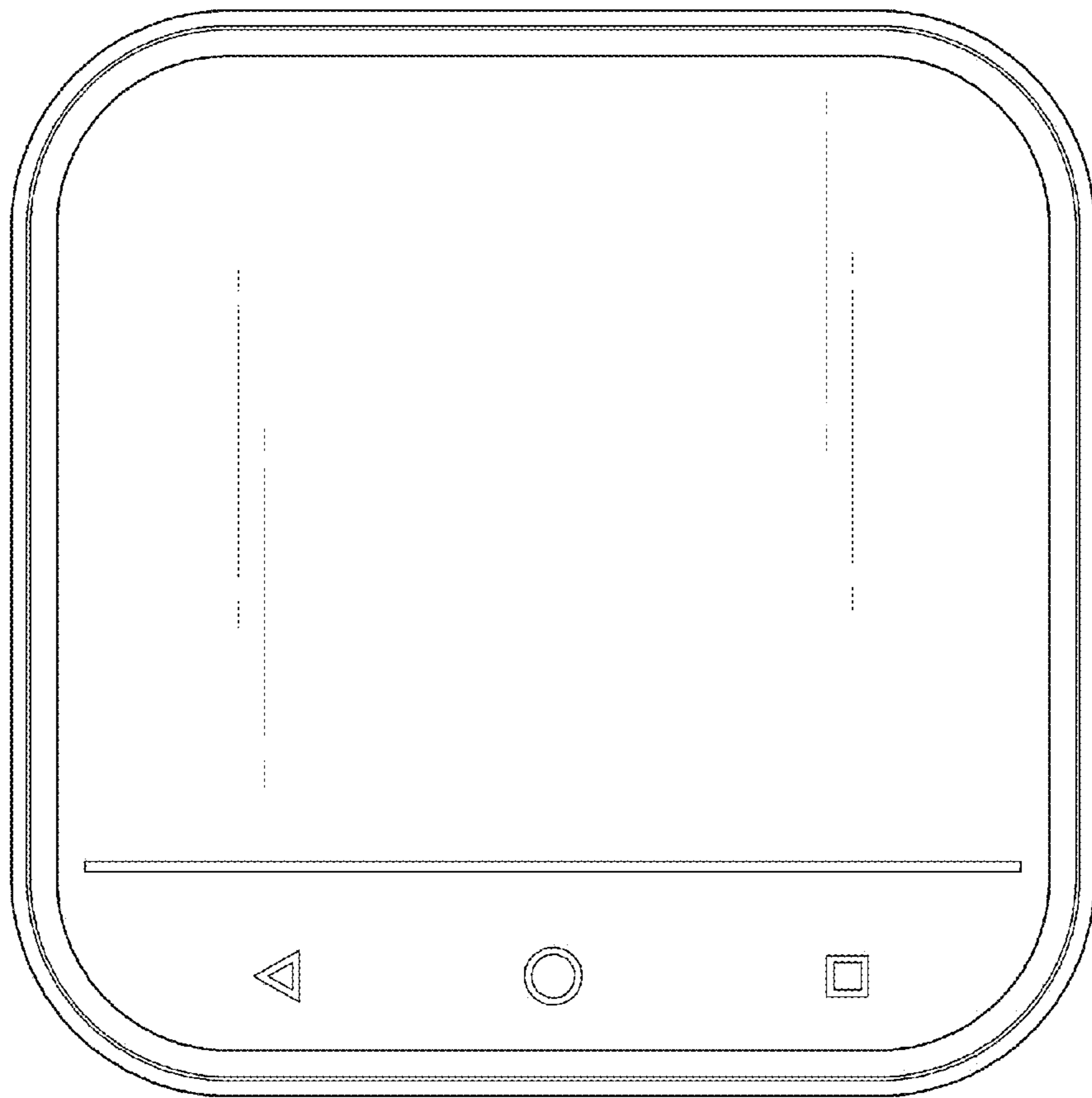

FIG. 29

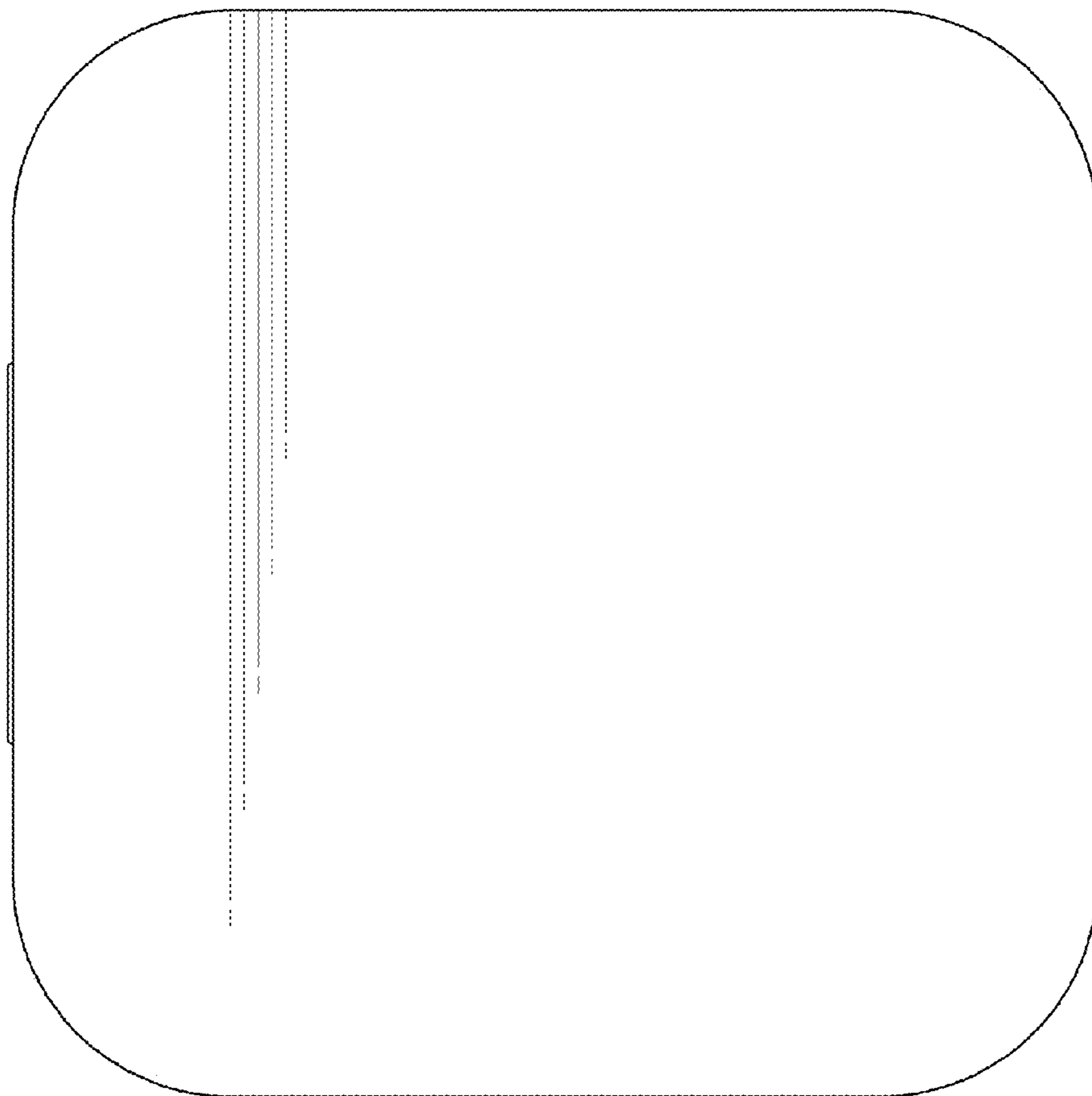

FIG. 30

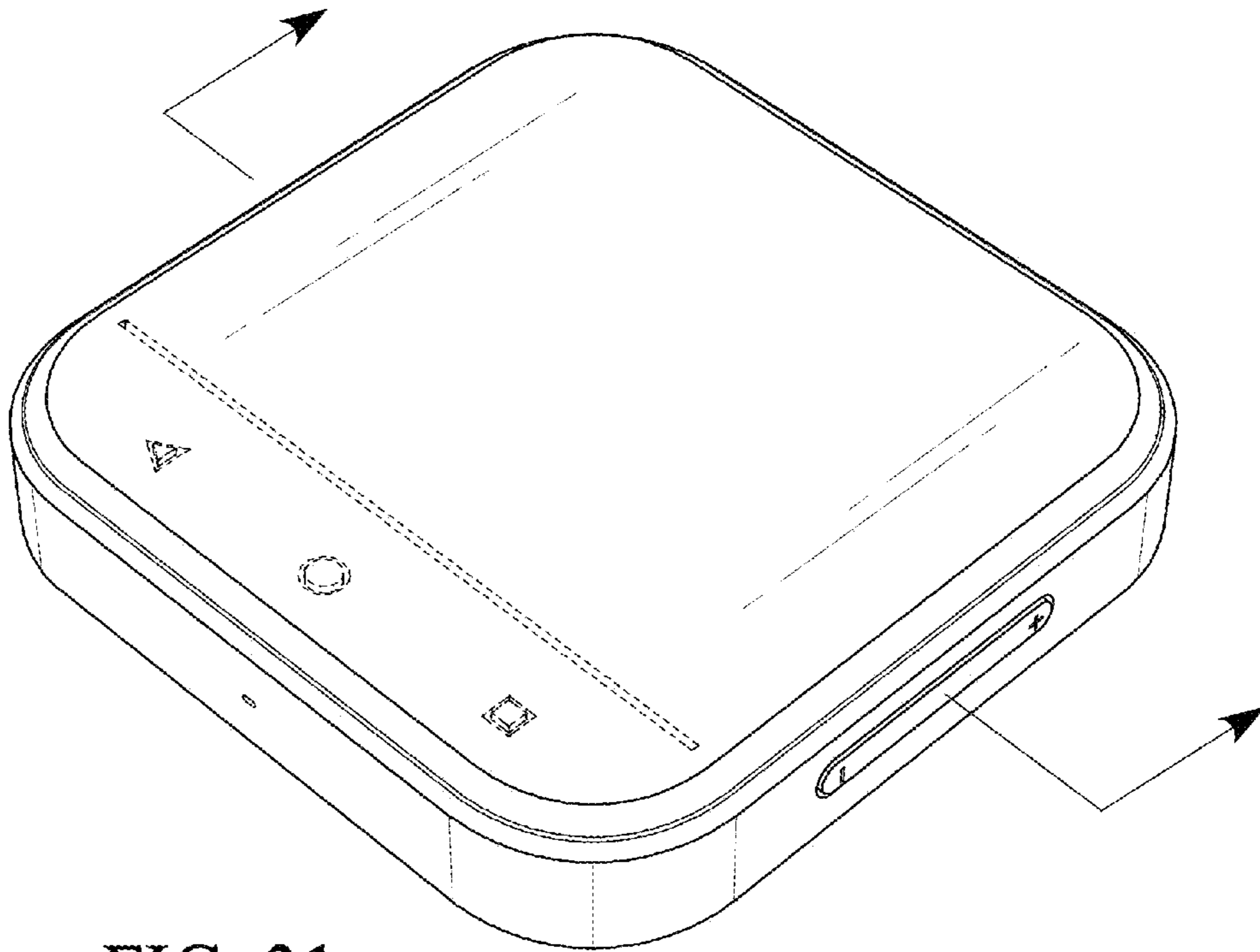

FIG. 31

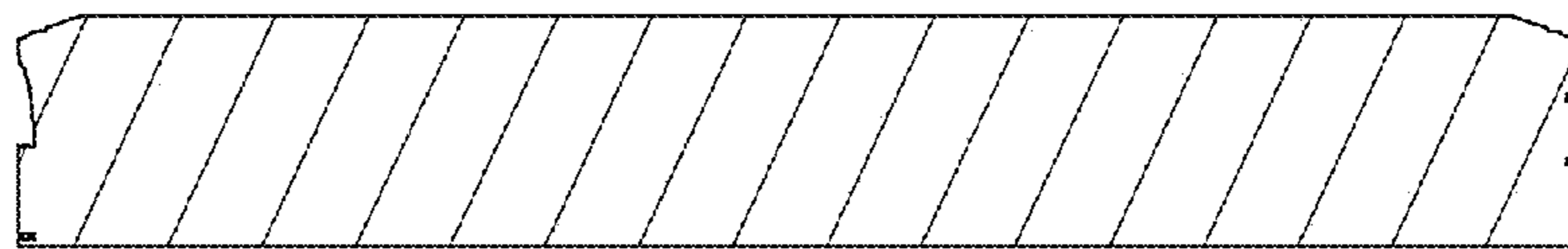
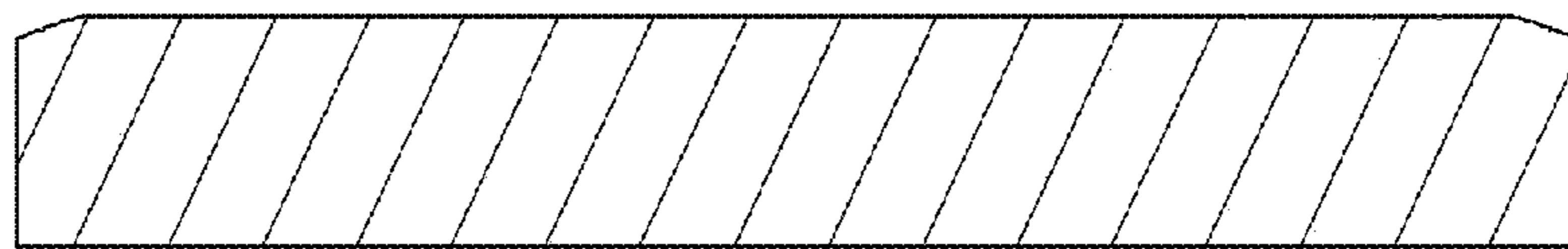
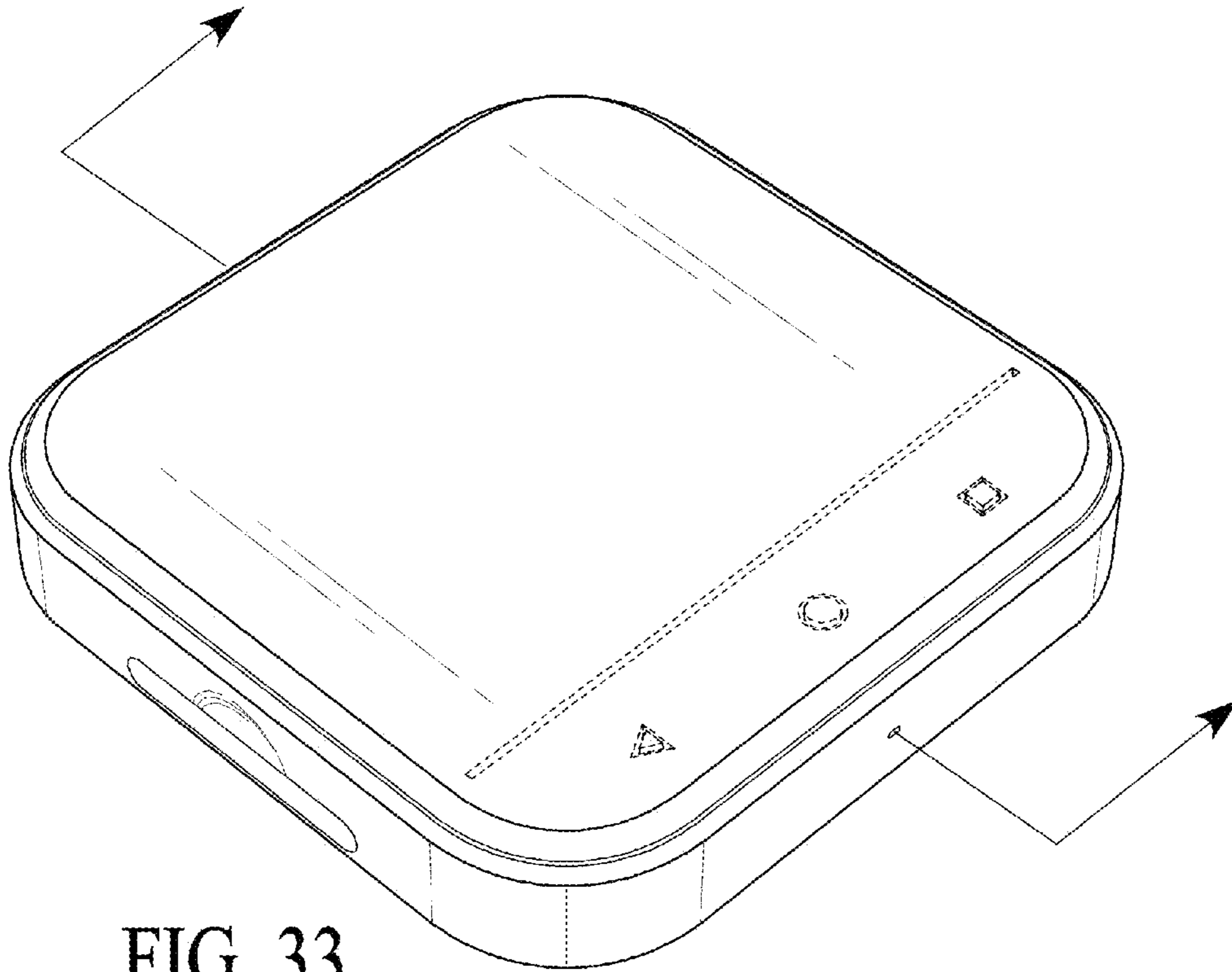

FIG. 32



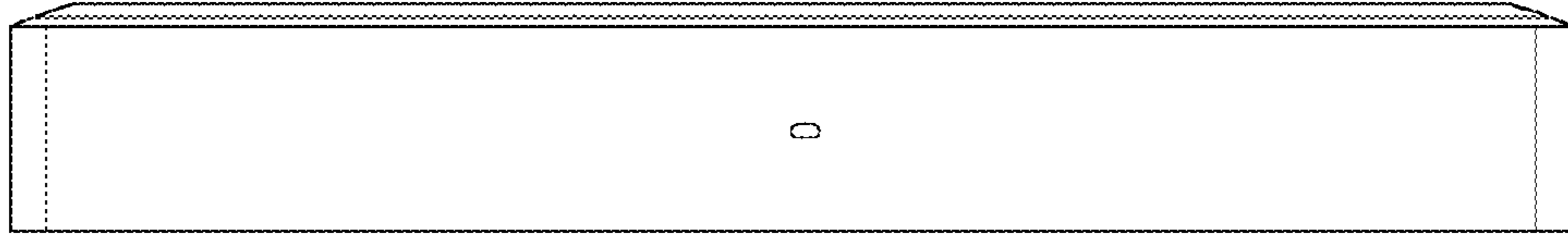

FIG. 35

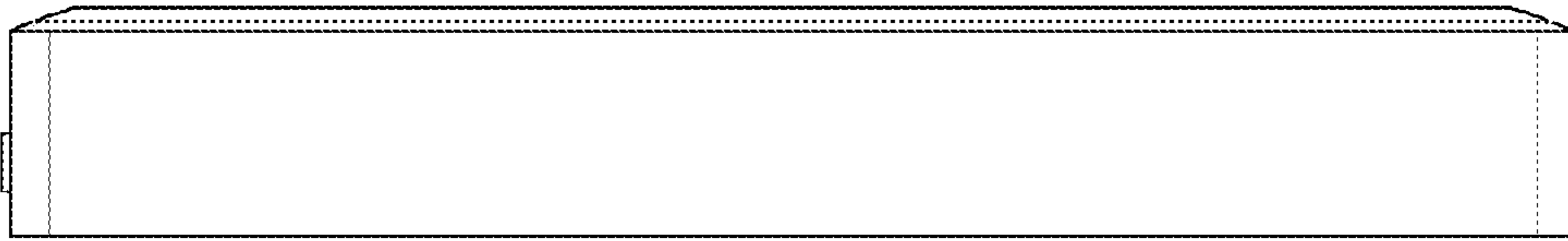

FIG. 36

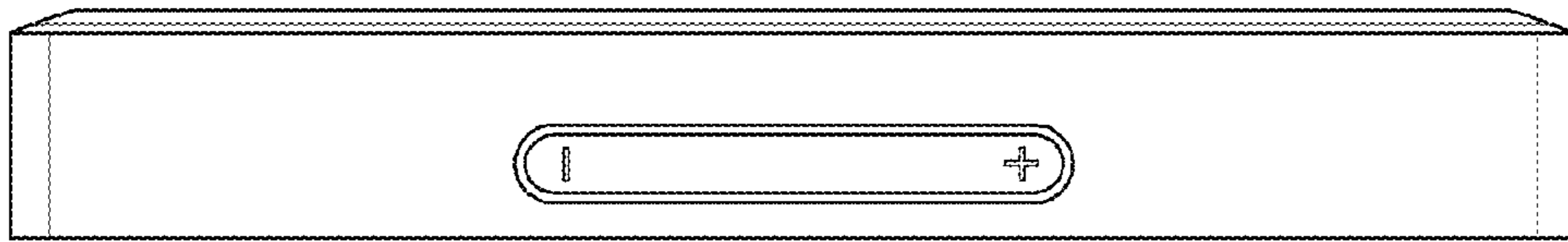

FIG. 37

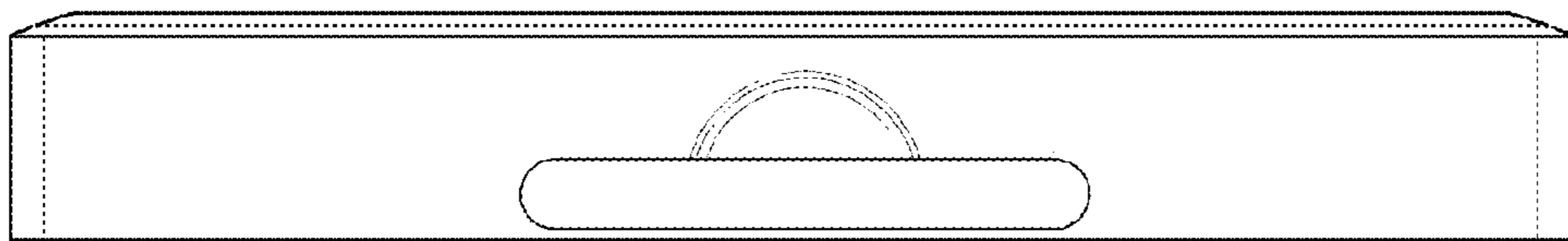

FIG. 38

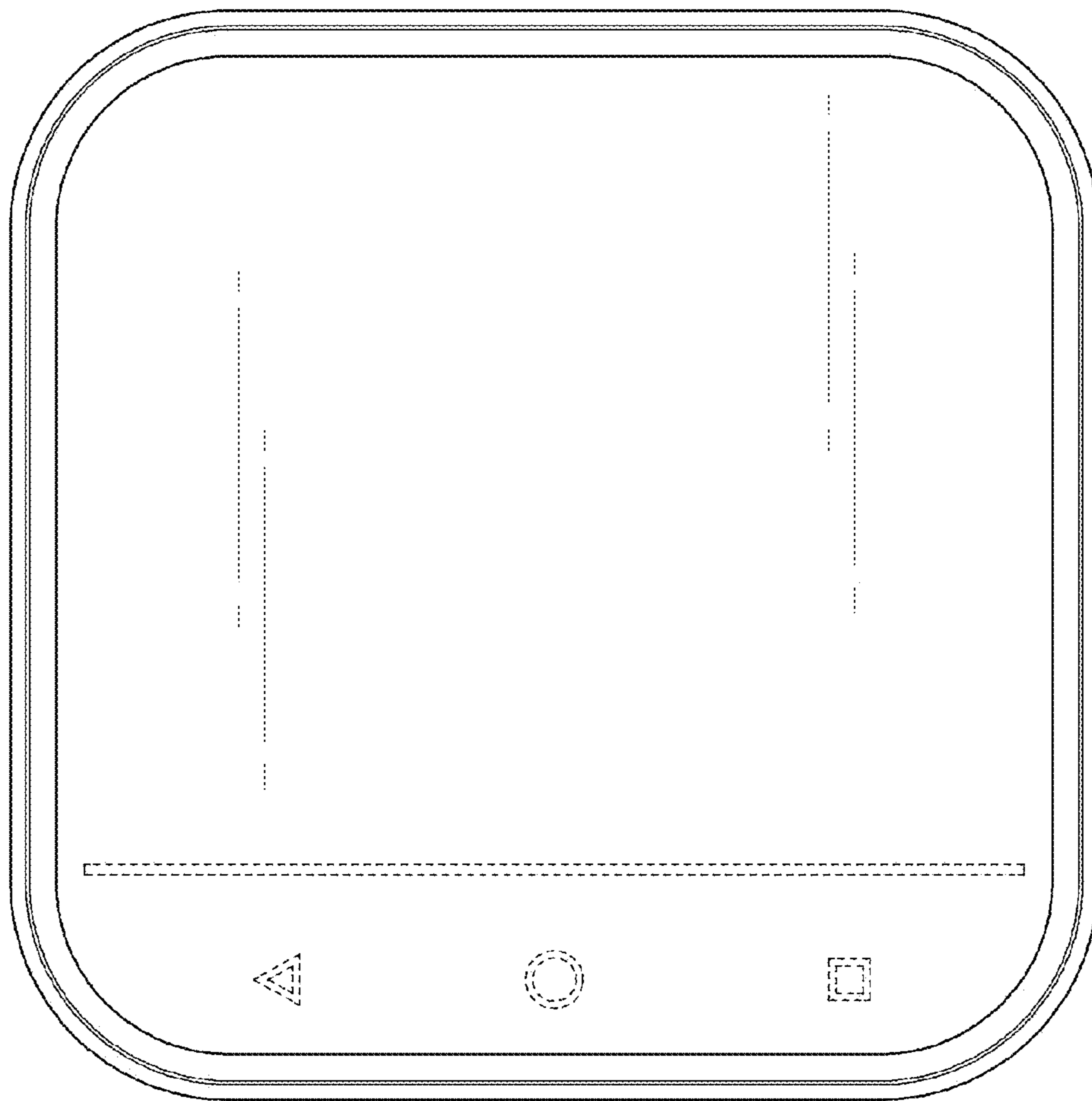

FIG. 39

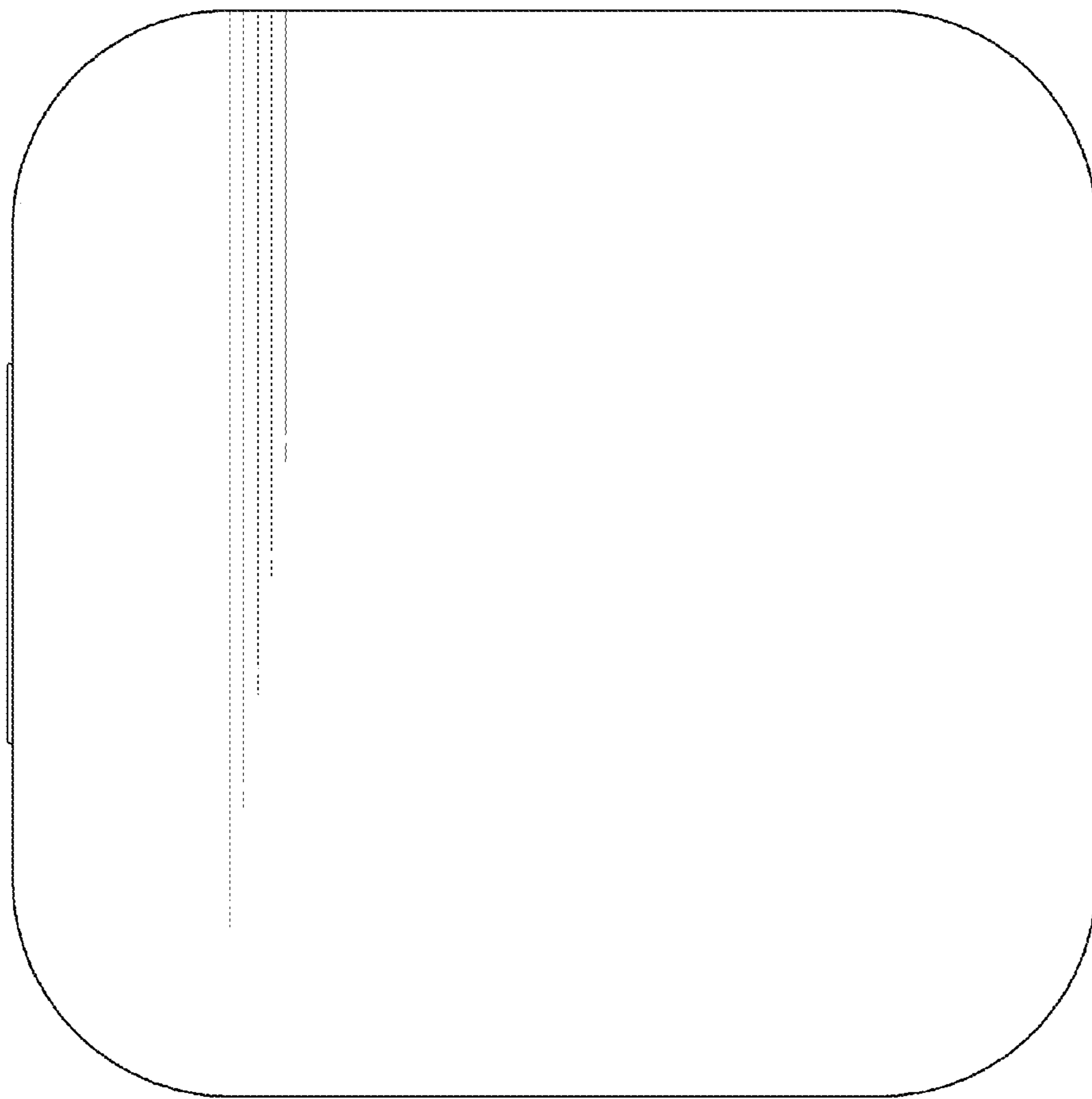

FIG. 40

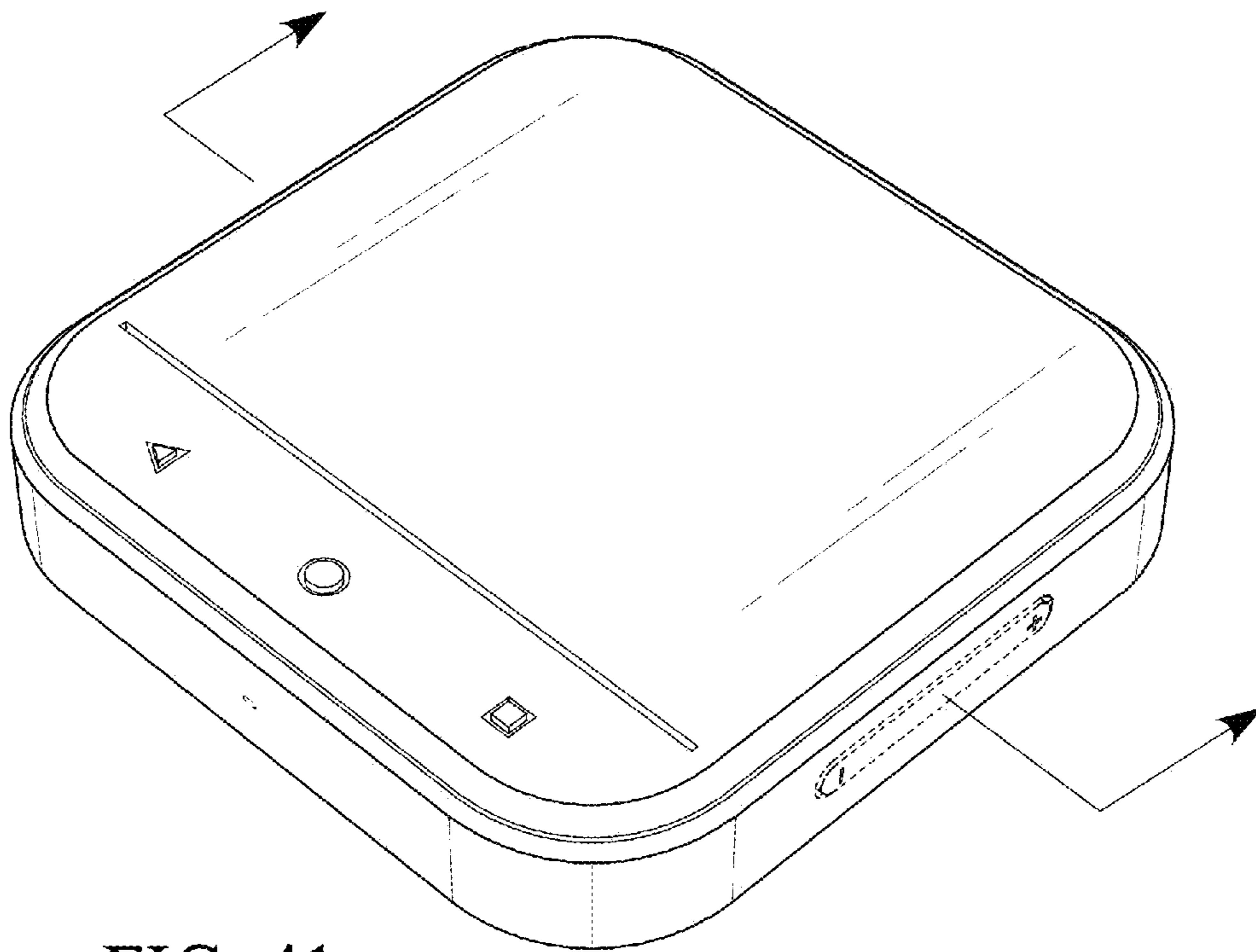

FIG. 41

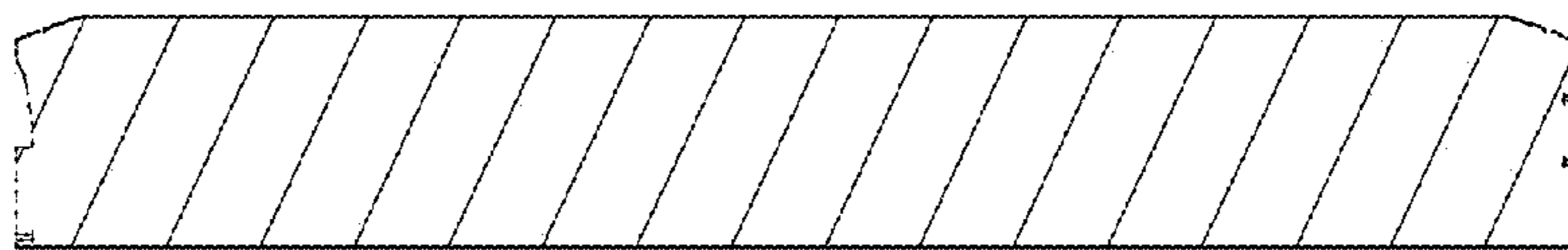

FIG. 42

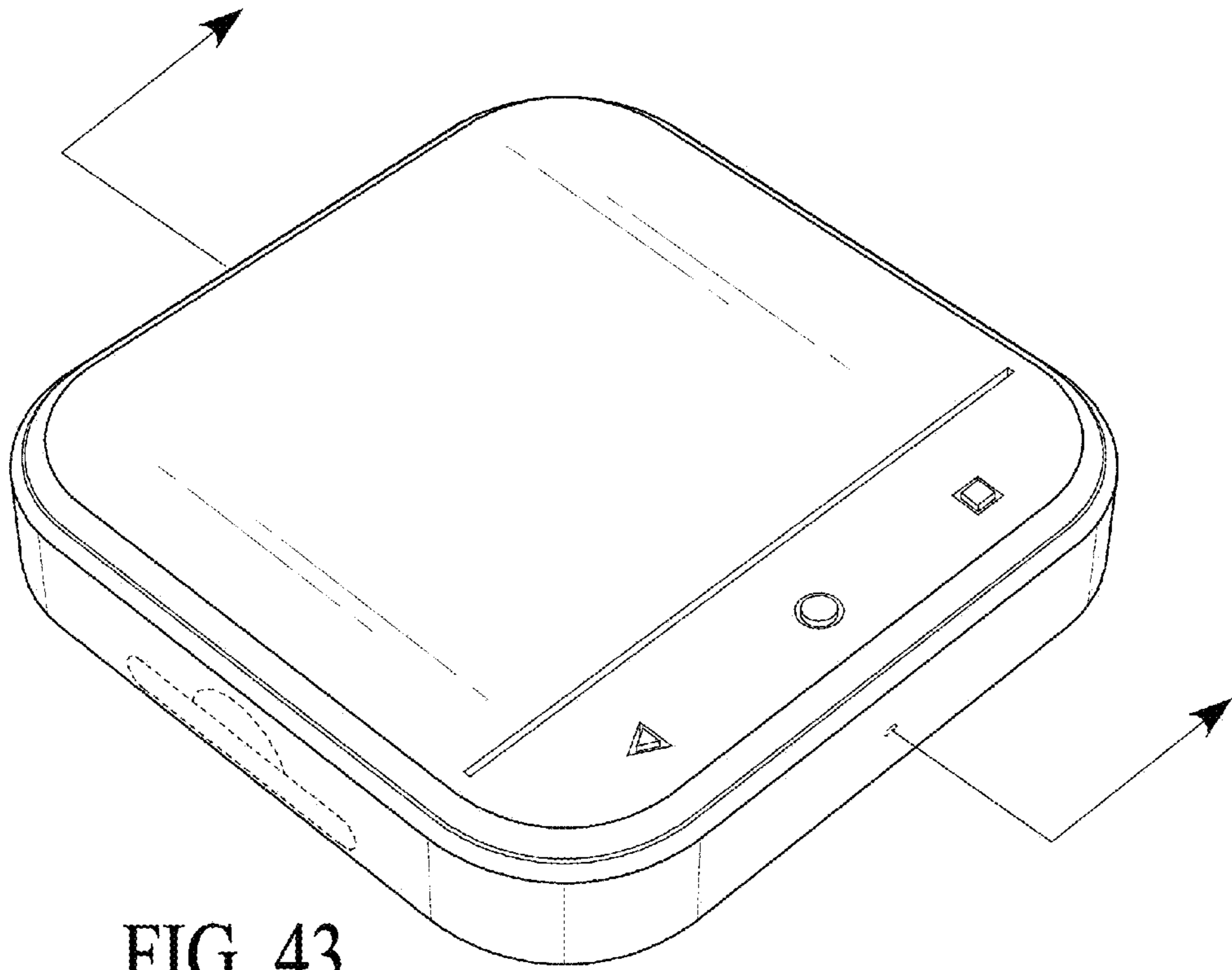

FIG. 43

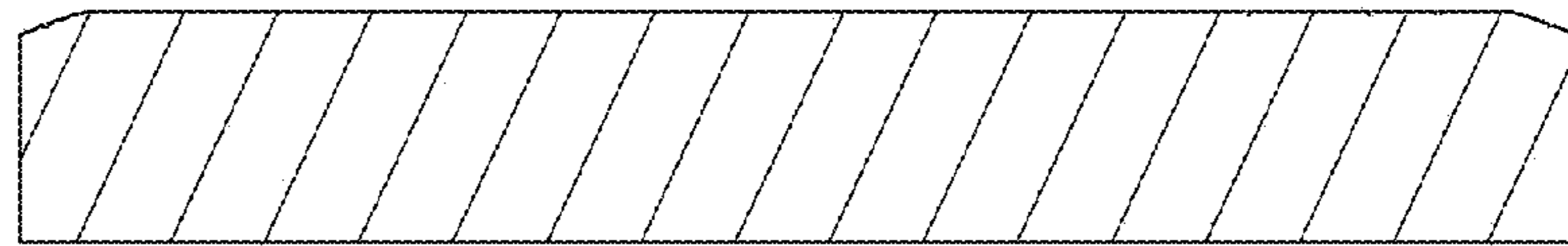

FIG. 44

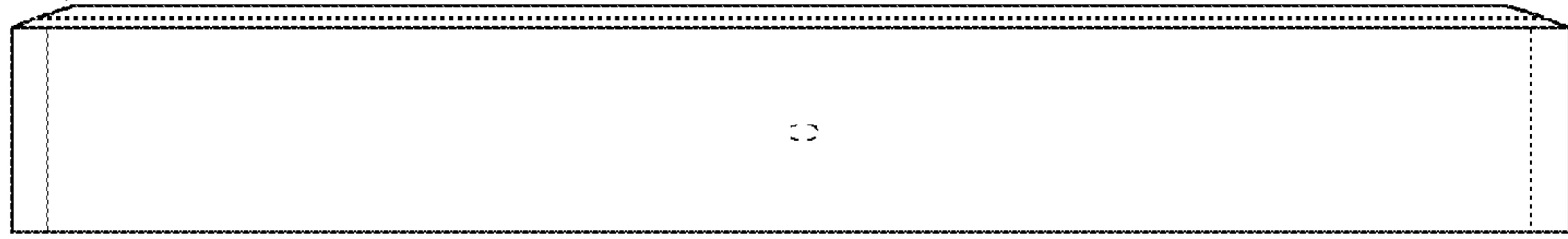

FIG. 45

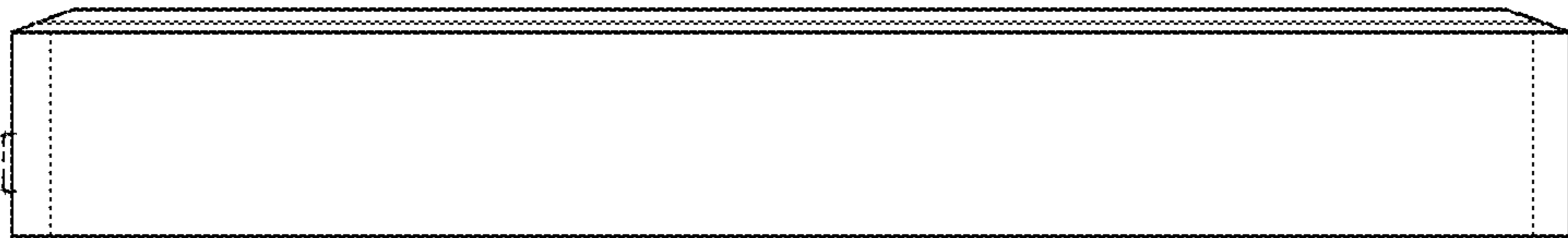

FIG. 46

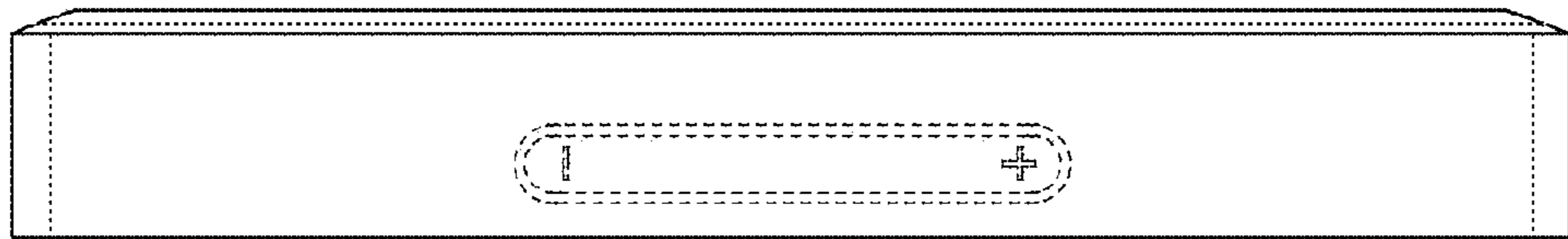

FIG. 47

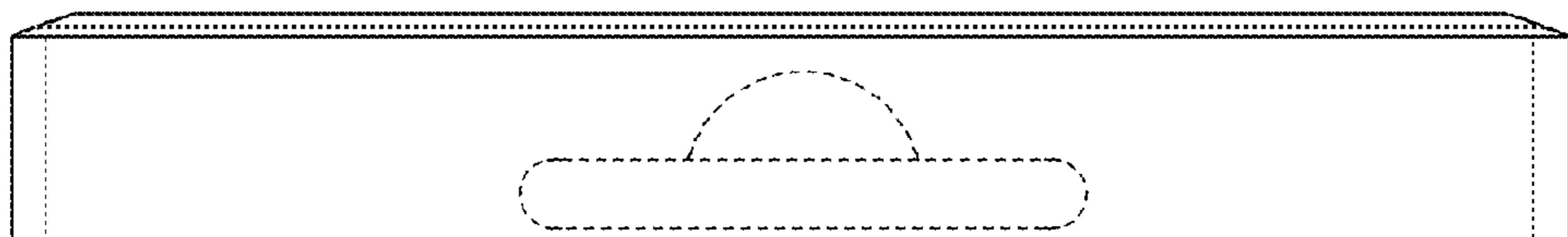

FIG. 48

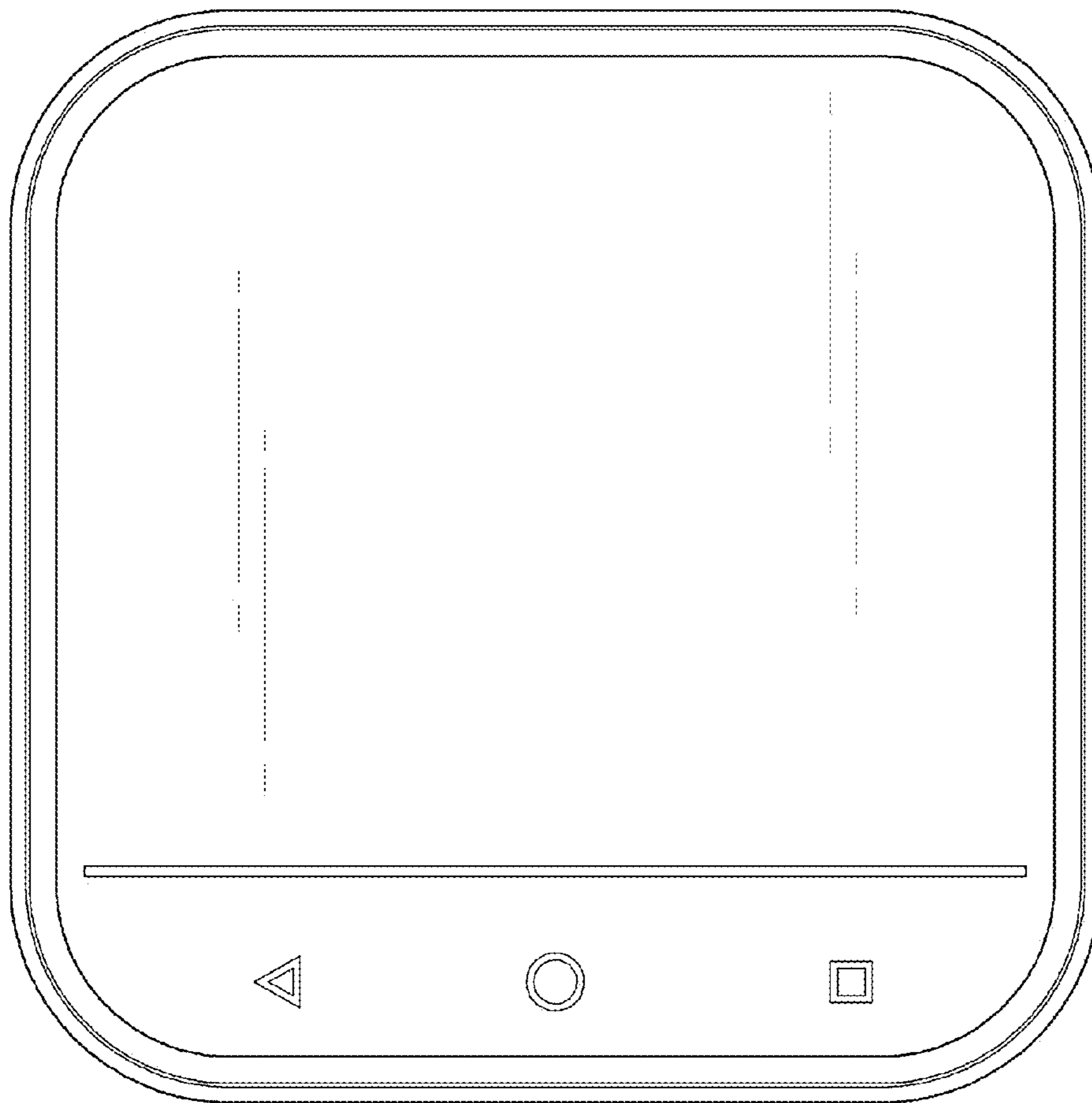

FIG. 49

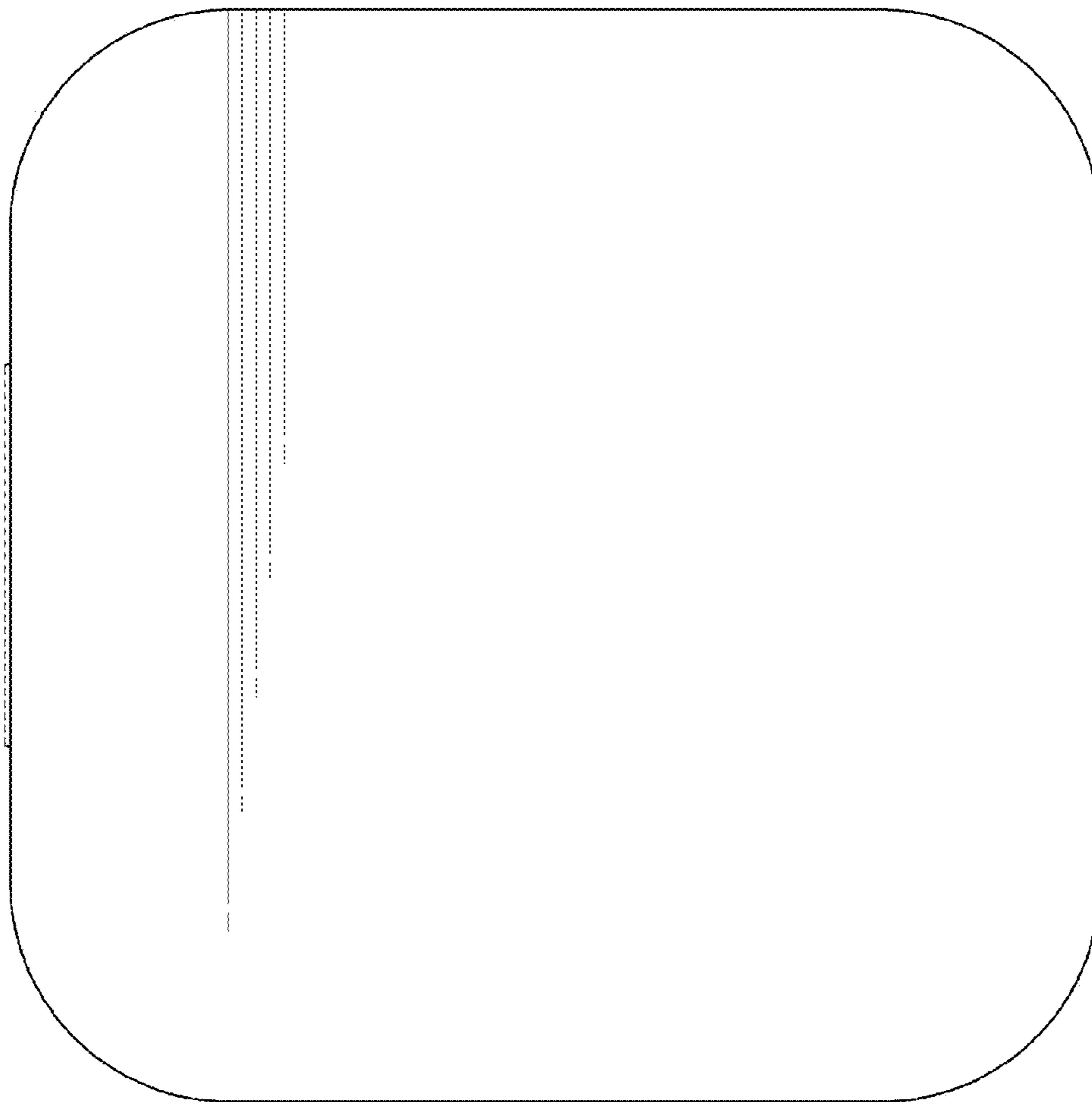

FIG. 50