



US00D766142S

(12) **United States Design Patent**  
**Renshaw et al.**

(10) **Patent No.:** **US D766,142 S**

(45) **Date of Patent:** **\*\* Sep. 13, 2016**

- (54) **TIE ROD AND NUT**
- (71) Applicant: **PULTRON COMPOSITES LIMITED**, Gisborne (NZ)
- (72) Inventors: **Peter Louis Renshaw**, Gisborne (NZ);  
**Everett Babbitt**, Bellingham, WA (US)
- (73) Assignee: **Pultron Composites Limited**, Gisborne (NZ)
- (\*\*) Term: **14 Years**
- (21) Appl. No.: **29/511,989**
- (22) Filed: **Dec. 16, 2014**
- (30) **Foreign Application Priority Data**

- Jun. 16, 2014 (NZ) ..... 418957
- (51) **LOC (10) Cl.** ..... **12-16**
- (52) **U.S. Cl.**  
USPC ..... **D12/159**
- (58) **Field of Classification Search**  
USPC ..... D12/194; D8/382-399  
CPC ..... E21D 21/0033; E21D 21/008; E21D 21/004; E21D 20/00; E21D 21/0006; E21D 21/0053; E21D 21/0073  
See application file for complete search history.

(56) **References Cited**

**U.S. PATENT DOCUMENTS**

- 3,227,031 A \* 1/1966 Williams ..... E04C 5/122  
411/26
- 3,358,549 A \* 12/1967 Lerich ..... E21D 21/008  
411/24
- 3,379,019 A \* 4/1968 Williams ..... E21D 20/021  
405/259.3
- 4,100,748 A \* 7/1978 Hansen ..... E21D 21/008  
405/259.3
- 4,619,559 A \* 10/1986 Norris ..... E21D 21/008  
405/259.1
- D336,388 S \* 6/1993 Reid ..... D6/672
- D354,905 S \* 1/1995 Fitzmyers ..... D8/387
- 5,775,850 A \* 7/1998 Gale ..... E21D 21/0026  
405/259.1

- 6,984,091 B2 \* 1/2006 Maltby ..... E21D 21/006  
405/259.1
- 7,318,689 B2 \* 1/2008 Kanflod ..... E21B 17/0426  
405/259.3
- 7,445,406 B2 \* 11/2008 Ortlepp ..... E21D 21/0026  
405/259.1
- D669,772 S \* 10/2012 Fox ..... D8/387
- D678,757 S \* 3/2013 Imai ..... D8/387
- 2007/0269274 A1 \* 11/2007 Seedsman ..... E21D 21/0033  
405/259.1
- 2007/0292231 A1 \* 12/2007 Boot ..... E21D 21/0006  
411/82
- 2008/0038068 A1 \* 2/2008 Craig ..... E21D 21/0046  
405/259.3

\* cited by examiner

*Primary Examiner* — Michael A Pratt

(74) *Attorney, Agent, or Firm* — Studebaker & Brackett PC

(57) **CLAIM**

The ornamental design for tie rod and nut, as shown and described.

**DESCRIPTION**

FIG. 1 is a top view showing my new design for tie rod and nut,  
 FIG. 2 is a side view of the nut, the opposite side being a mirror image thereof,  
 FIG. 3 is a top view thereof, the bottom view being a mirror image thereof,  
 FIG. 4 is a rear view thereof,  
 FIG. 5 is a front view thereof,  
 FIG. 6 is a front perspective view thereof,  
 FIG. 7 is a rear perspective view thereof,  
 FIG. 8 is a perspective view of the tie rod,  
 FIG. 9 is a greatly enlarged view of the left side view thereof, the ends of the tie rod are shown broken away for ease of illustration,  
 FIG. 10 is a greatly enlarged view of the right side view thereof, the ends of the tie rod are shown broken away for ease of illustration,  
 FIG. 11 is a front view thereof; and,  
 FIG. 12 is a rear view thereof.  
 The design is shown broken apart along its length to indicate that no specific length is claimed.

**1 Claim, 10 Drawing Sheets**

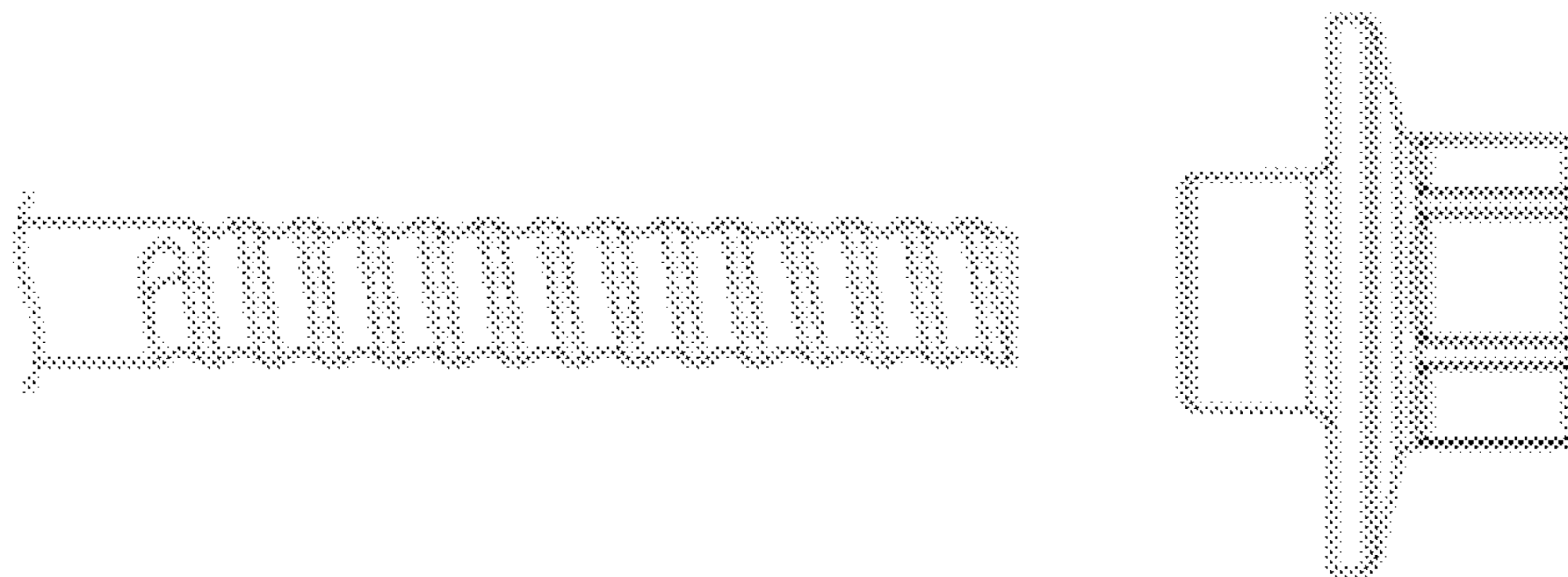

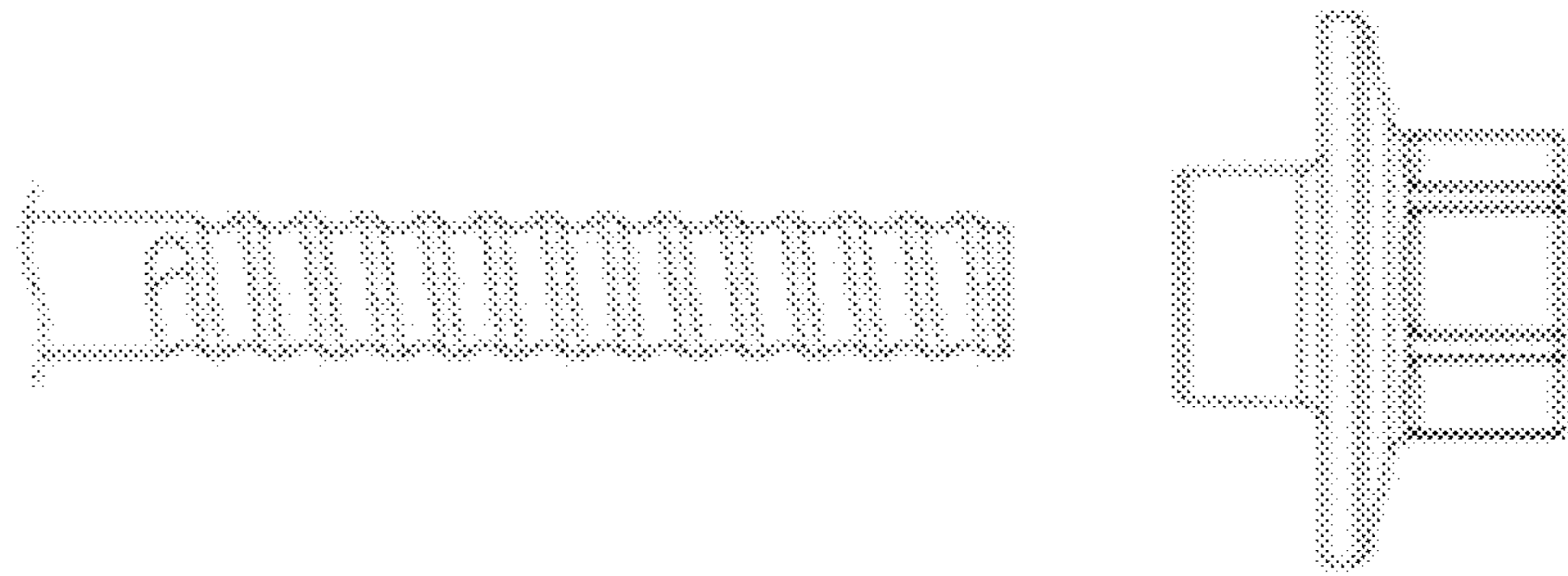

FIG. 1

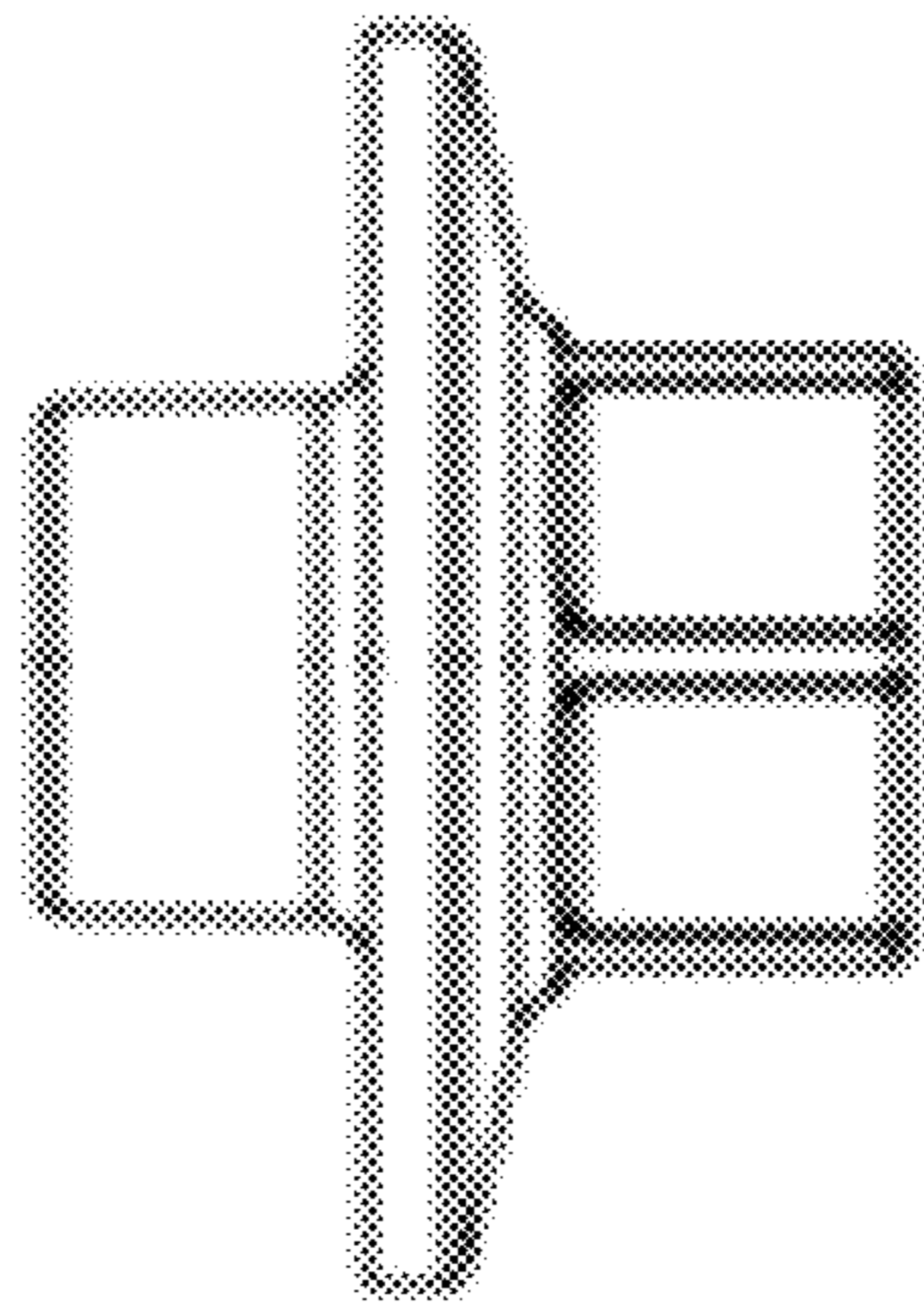

FIG. 2

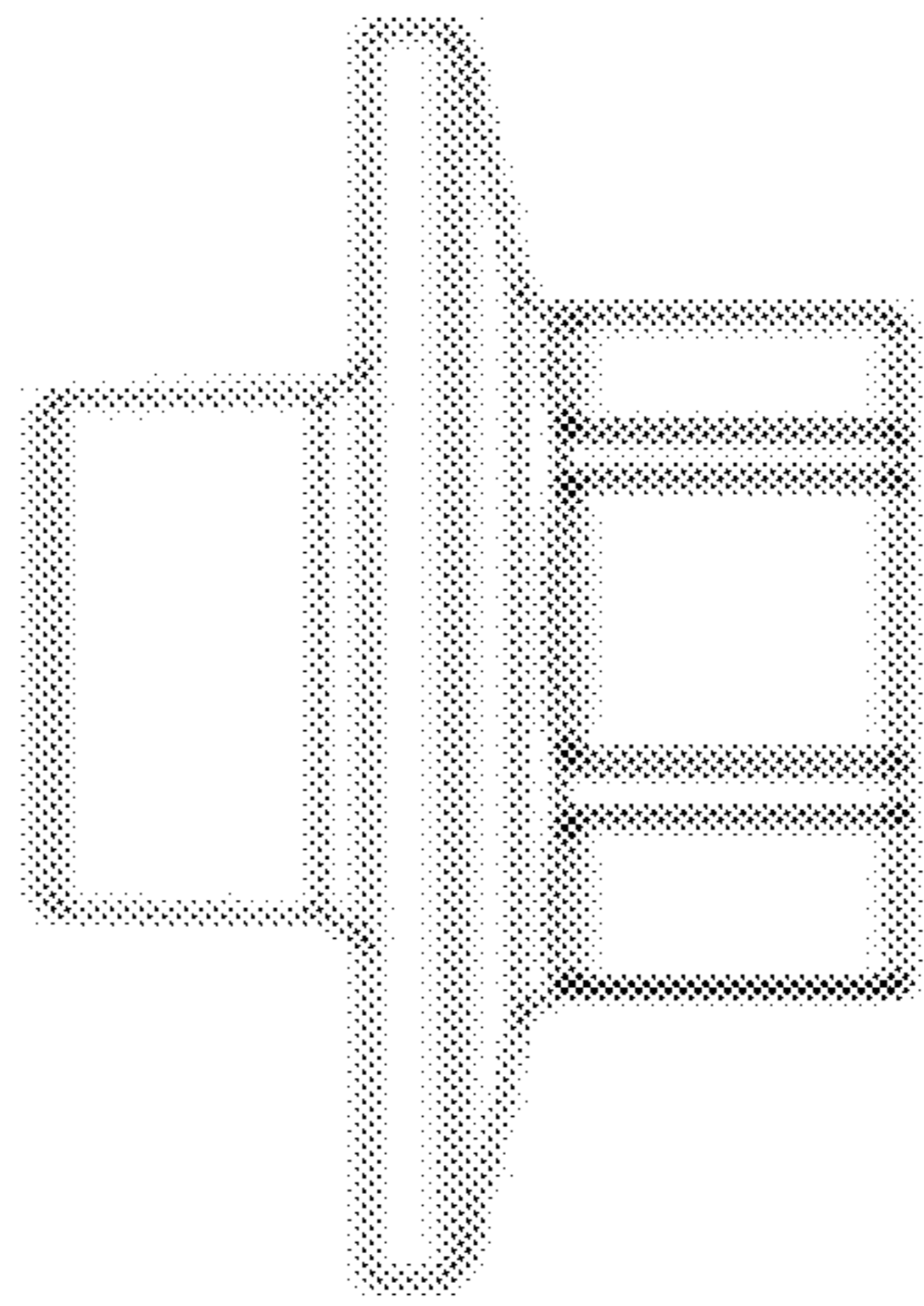

FIG. 3

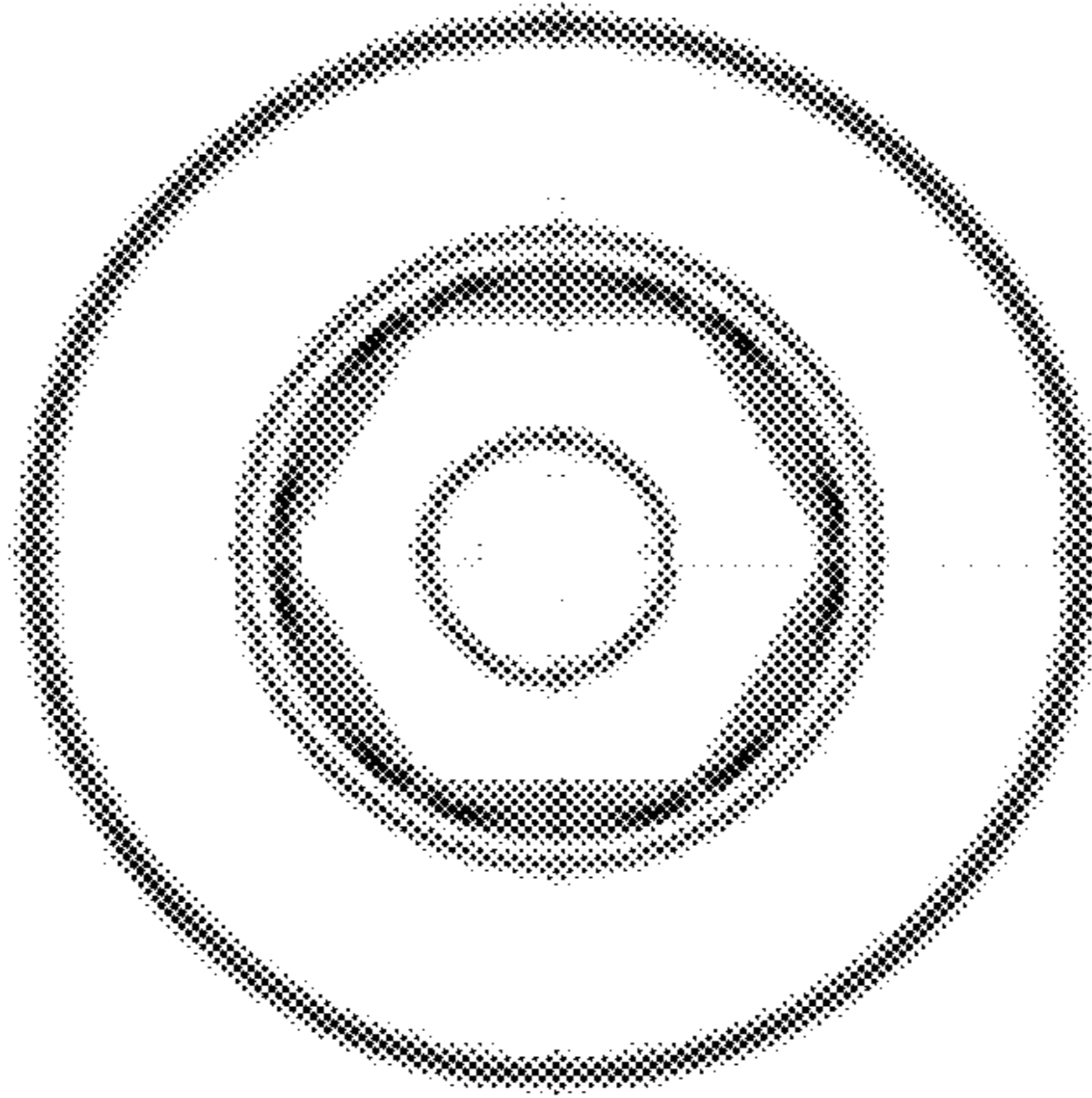

FIG. 4

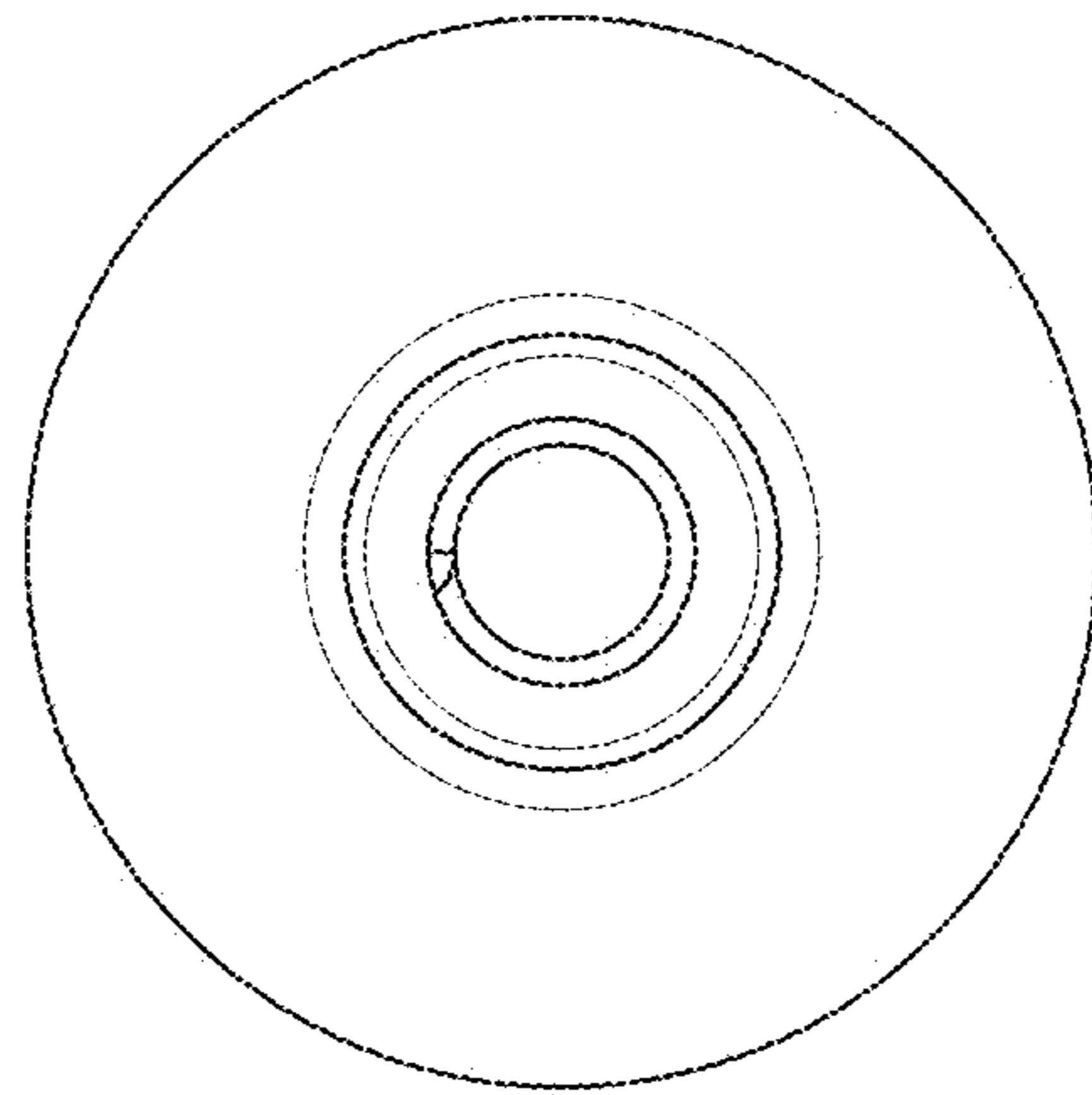

FIG. 5

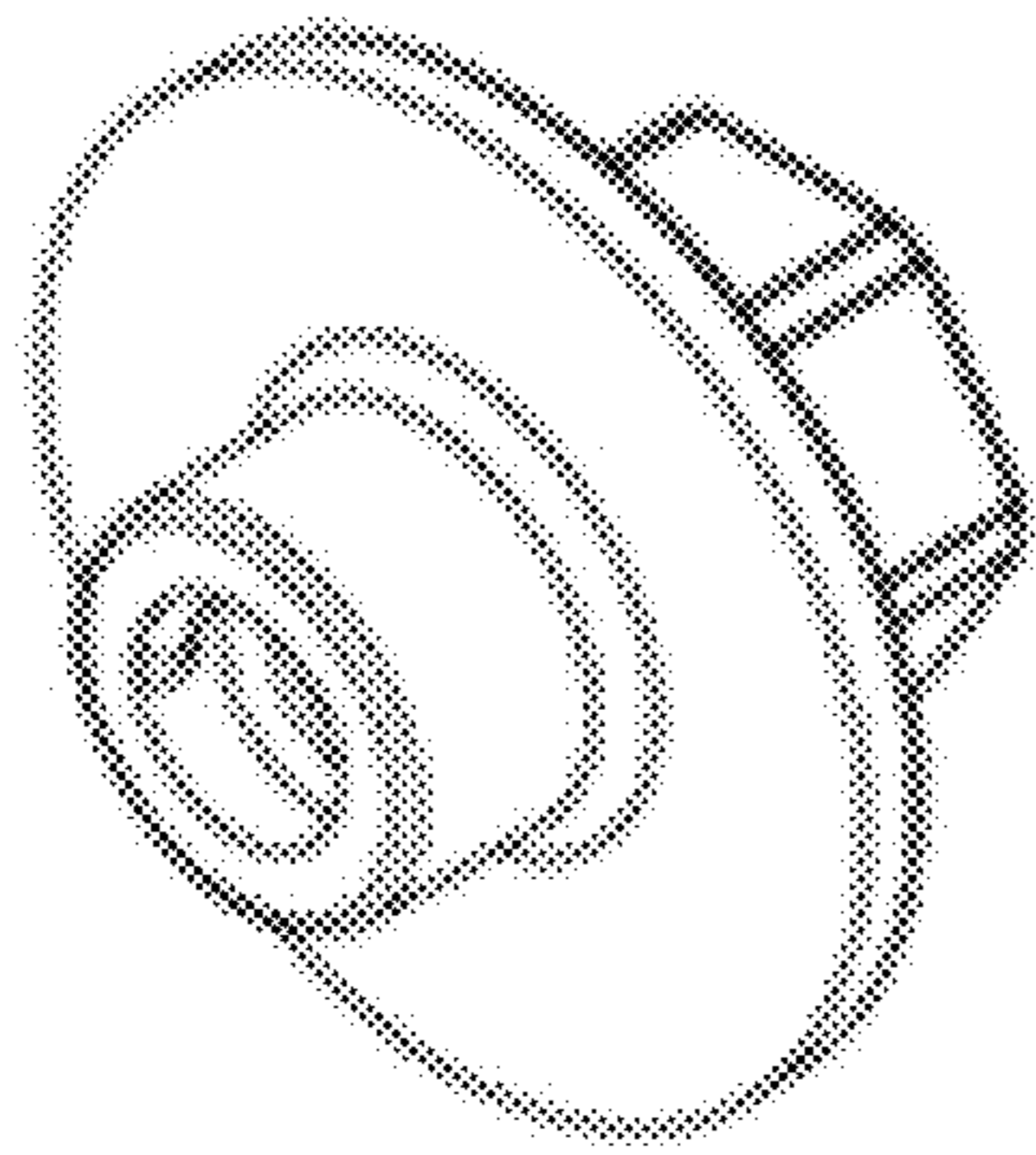

FIG. 6

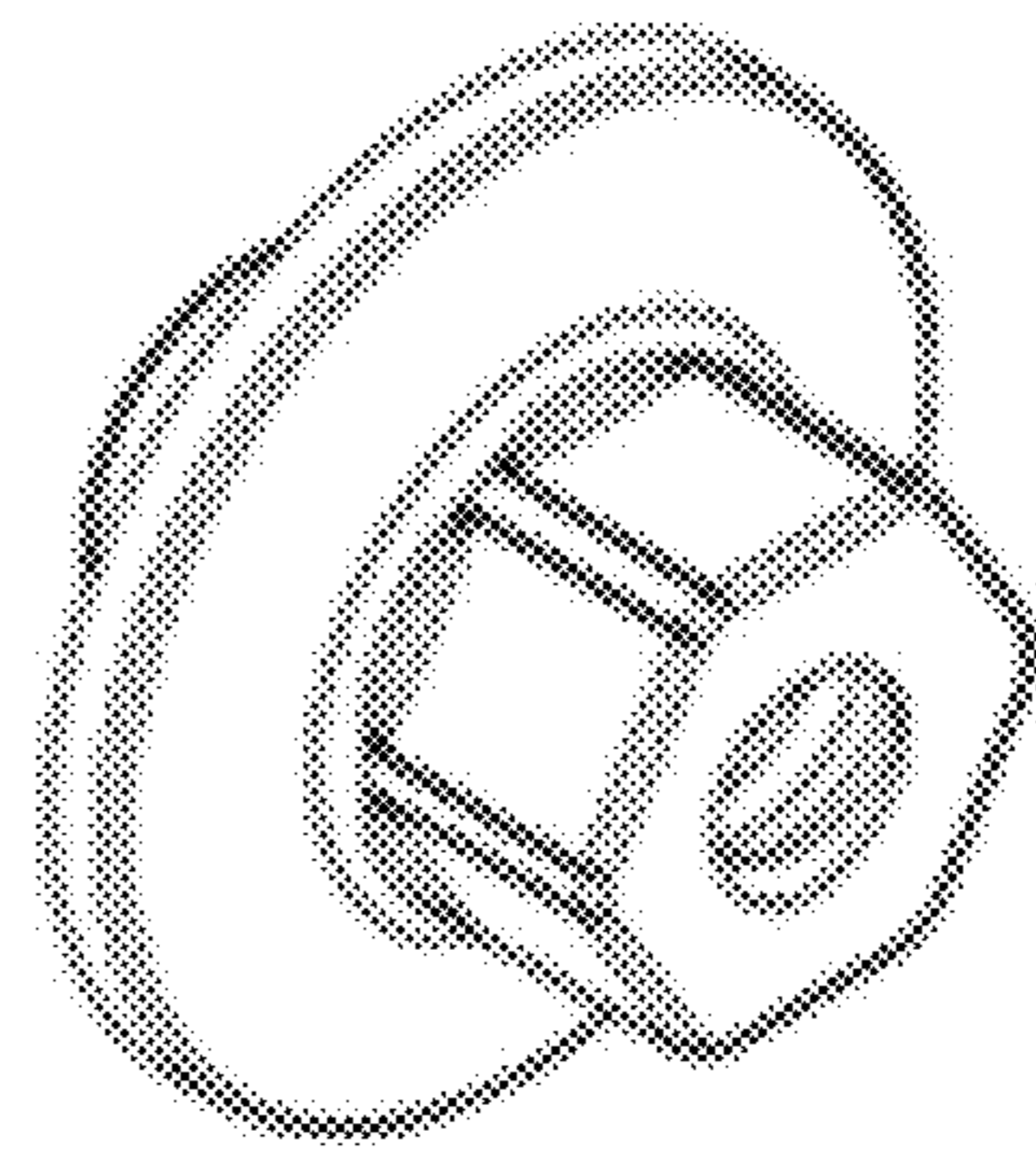

FIG. 7

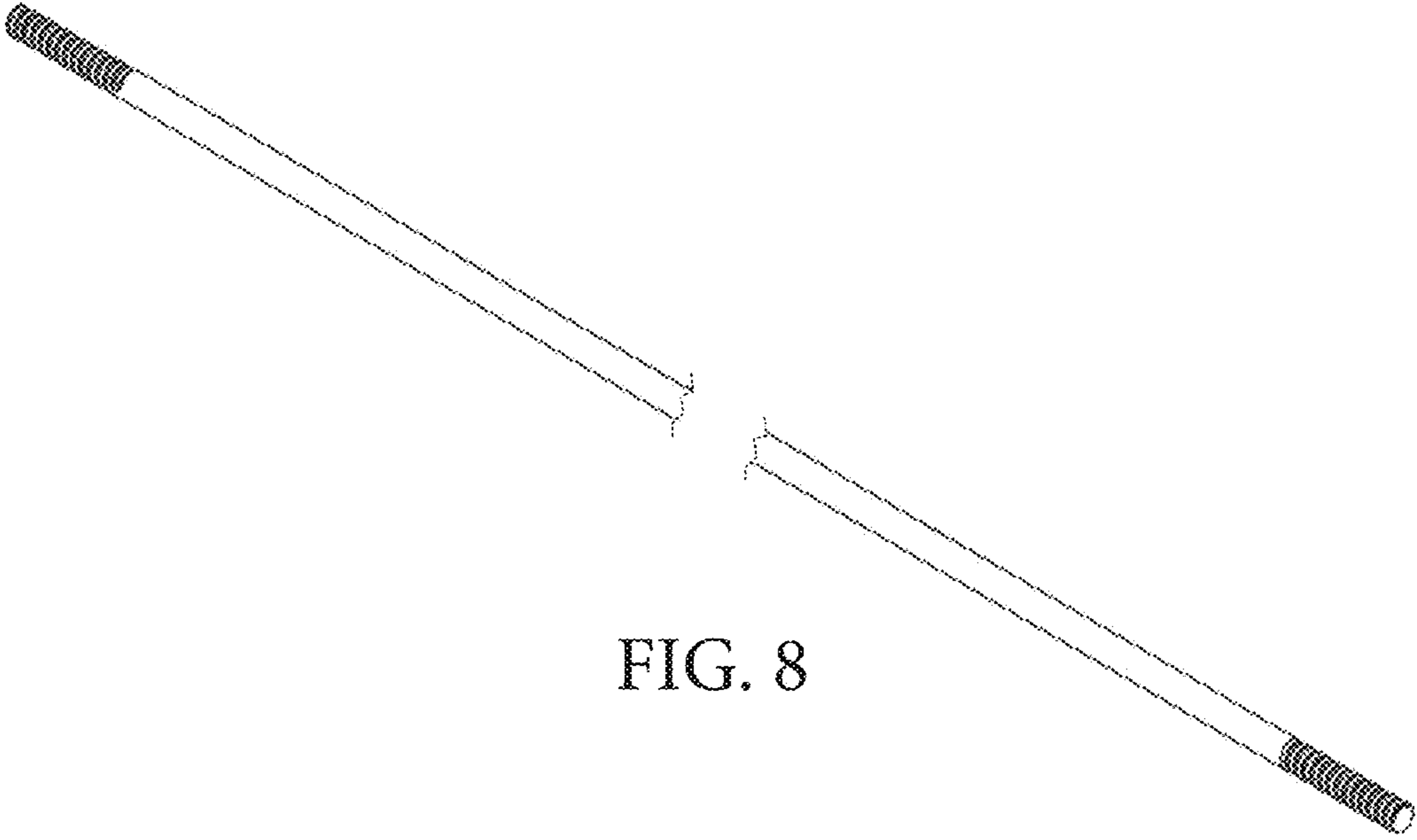

FIG. 8



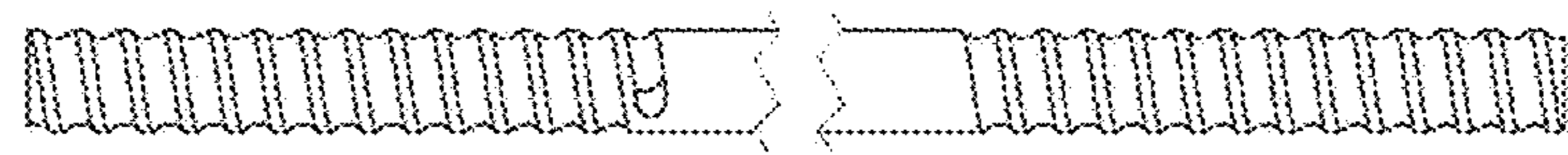

FIG. 9

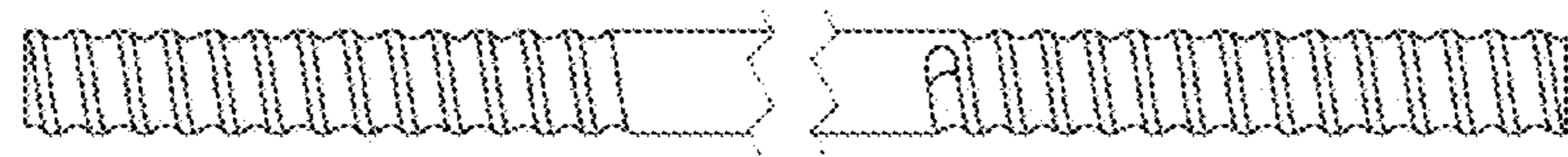

FIG. 10

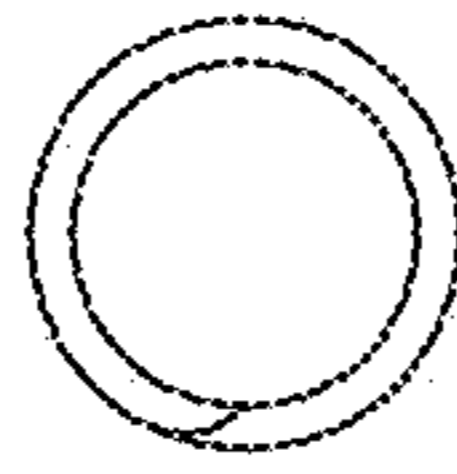

FIG. 11

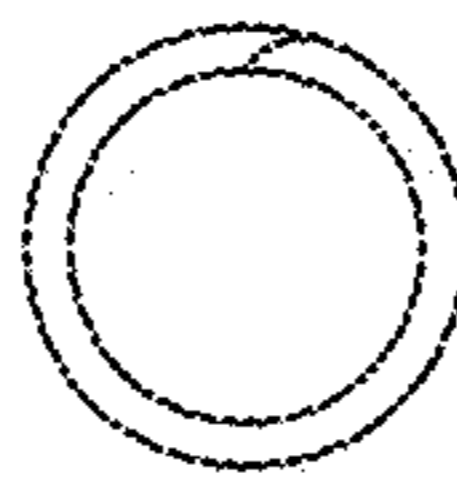

FIG. 12