



US00D765827S

(12) **United States Design Patent** (10) **Patent No.:** **US D765,827 S**
Bowen (45) **Date of Patent:** **** Sep. 6, 2016**

(54) **AIR VENT**

(56) **References Cited**

(71) Applicant: **Bentley Motors Limited**, Cheshire (GB)

U.S. PATENT DOCUMENTS

(72) Inventor: **George Bowen**, Crewe (GB)

D261,925 S *	11/1981	Laakkonen	D23/421
D273,702 S *	5/1984	Widerby	D23/393
D328,875 S *	8/1992	Perkins	D10/121
D342,990 S *	1/1994	Jaroszczyk	D23/365
D393,709 S *	4/1998	Nishizawa	D23/382
D410,707 S *	6/1999	Krog	D21/488
D468,008 S *	12/2002	Fraser	D23/390
D521,631 S *	5/2006	Habensus	D23/388
D570,981 S *	6/2008	McClelland	D23/370
D581,723 S *	12/2008	Pan	D23/261
D607,555 S *	1/2010	Nishizawa	D23/393
D681,184 S *	4/2013	Romero Carreras	D23/370
D681,796 S *	5/2013	Han	D23/390

(73) Assignee: **BENTLEY MOTORS LIMITED**, Crewe, Cheshire (GB)

(**) Term: **14 Years**

(21) Appl. No.: **29/511,900**

(22) Filed: **Dec. 15, 2014**

* cited by examiner

Related U.S. Application Data

Primary Examiner — David Muller

(63) Continuation-in-part of application No. 29/430,747, filed on Aug. 29, 2012, now abandoned.

(74) *Attorney, Agent, or Firm* — Barlow, Josephs & Holmes, Ltd.

(30) **Foreign Application Priority Data**

(57) **CLAIM**

The ornamental design for an air vent, as shown and described.

Mar. 1, 2012 (EM) 2000885

DESCRIPTION

(51) **LOC (10) Cl.** **23-04**

(52) **U.S. Cl.**
USPC **D23/393**

(58) **Field of Classification Search**

USPC D23/385–395, 397, 370–373, 365, 354, D23/399–403, 421, 499; 454/309, 275–277, 454/284, 287–291, 358–363; 52/302.1, 52/32.07; 285/229, 189, 183, 123.1, 15, 285/114, 110, 424, 197

CPC F24F 7/00; F24F 7/013; F24F 13/082; F24F 13/10; F24F 13/16

See application file for complete search history.

FIG. 1 is a perspective view of an air vent in accordance with the present design;
FIG. 2 is a front plan view thereof;
FIG. 3 is a rear plan view thereof;
FIG. 4 is a side elevation view thereof; and,
FIG. 5 is a perspective view thereof showing an air vane in broken line.

The portions of the drawings illustrated in broken line are included for environmental purposes only, and do not form a part of the claimed design.

1 Claim, 5 Drawing Sheets

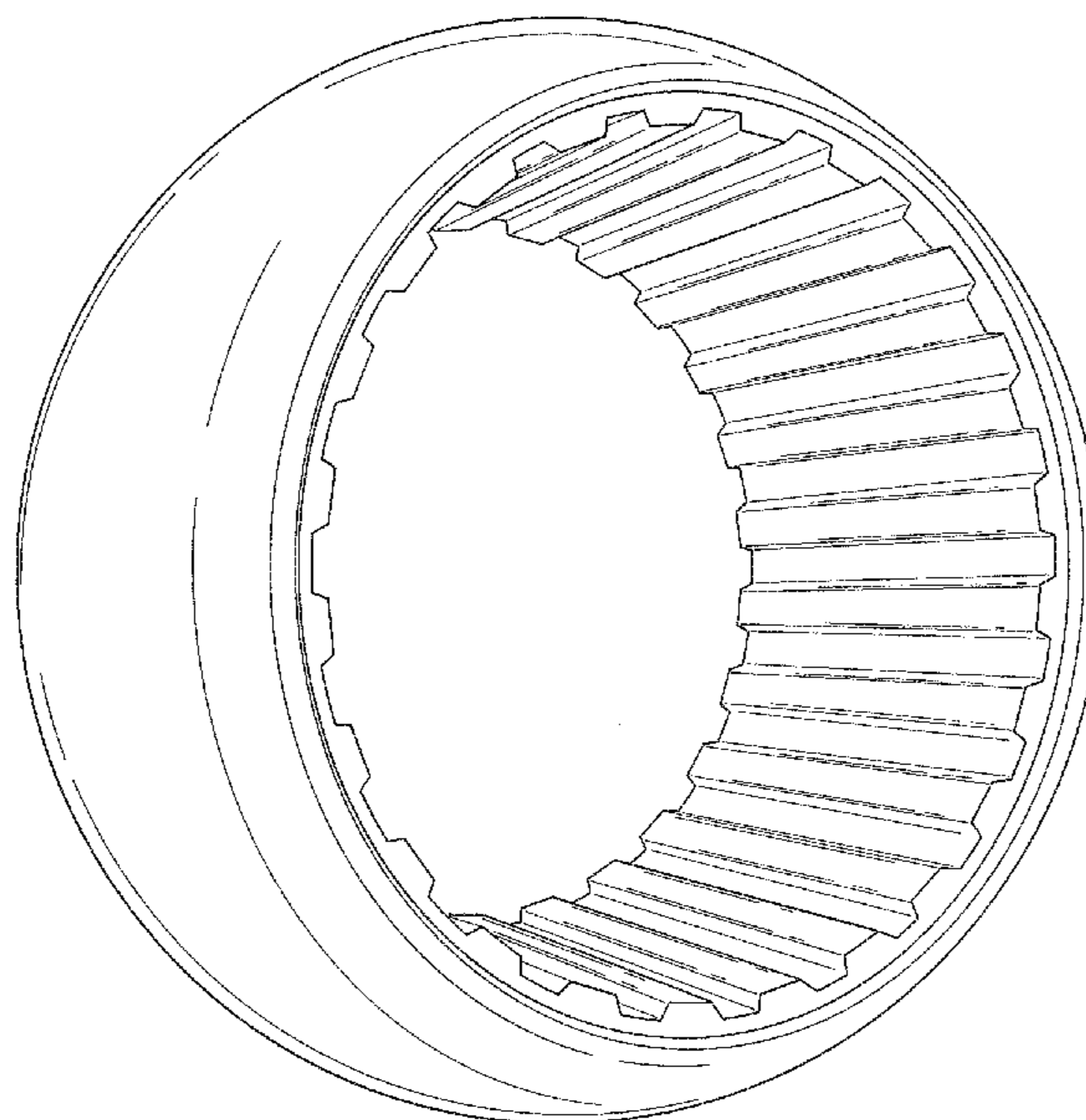

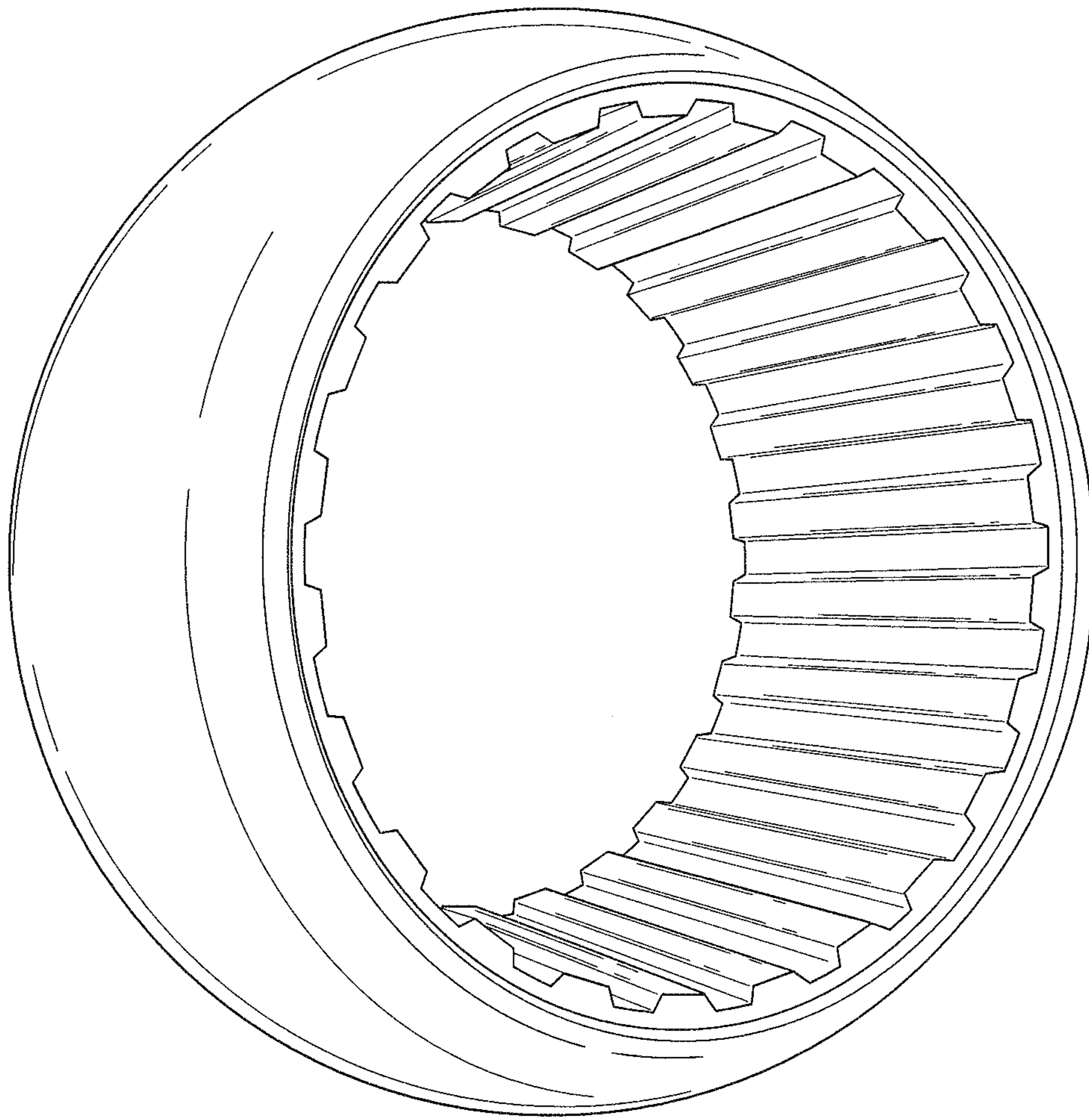

FIG. 1

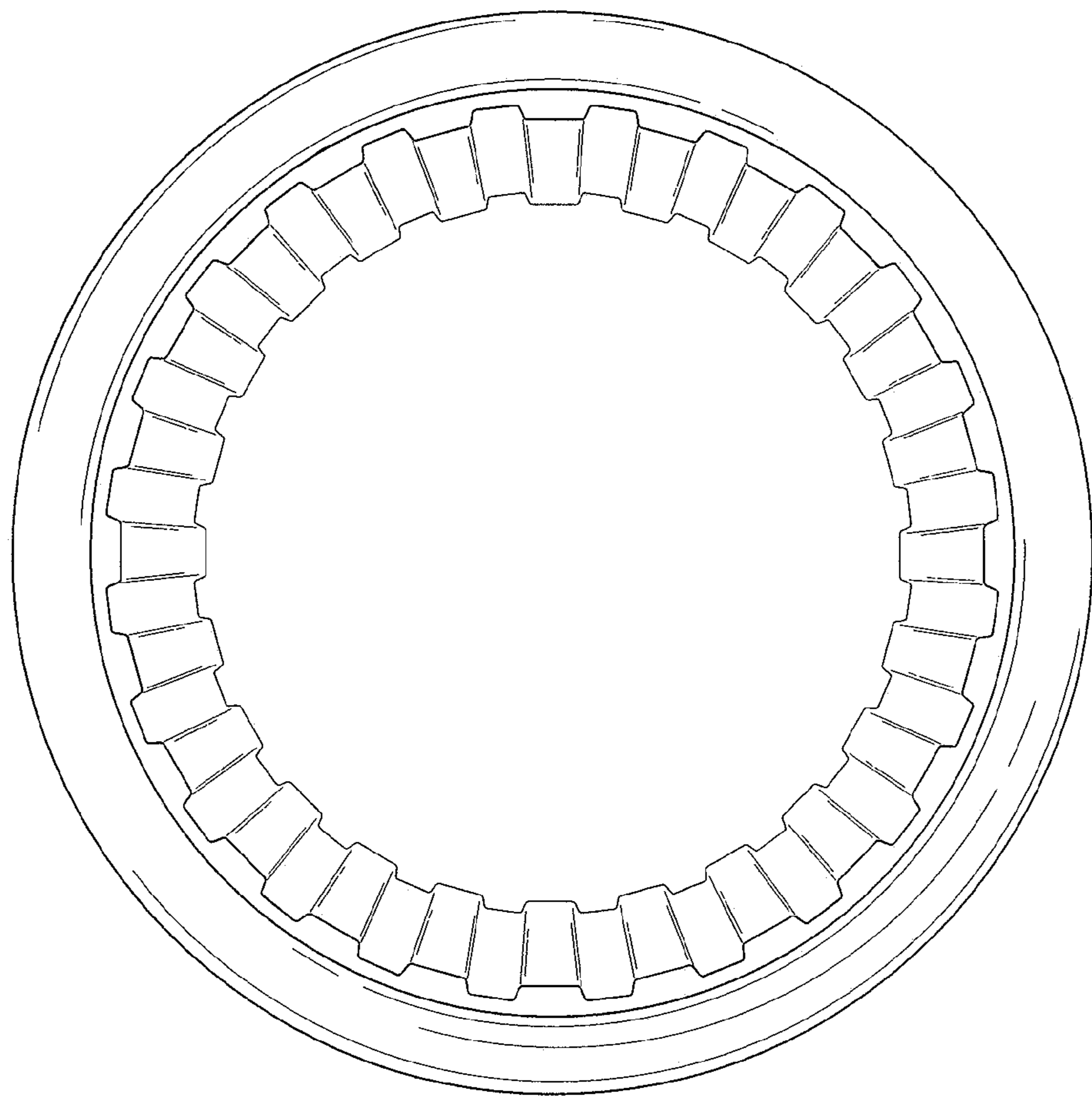

FIG. 2

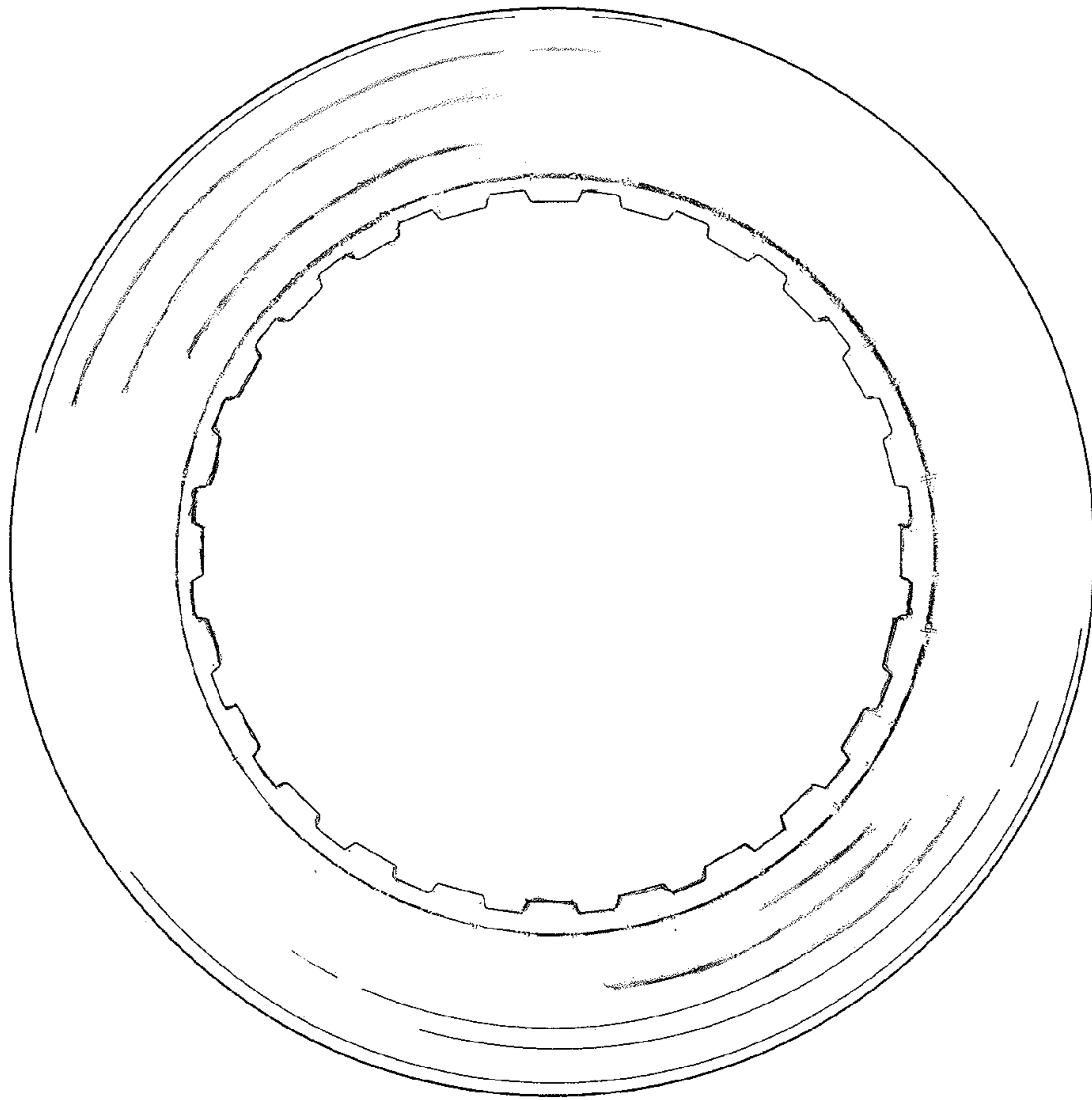

FIG. 3

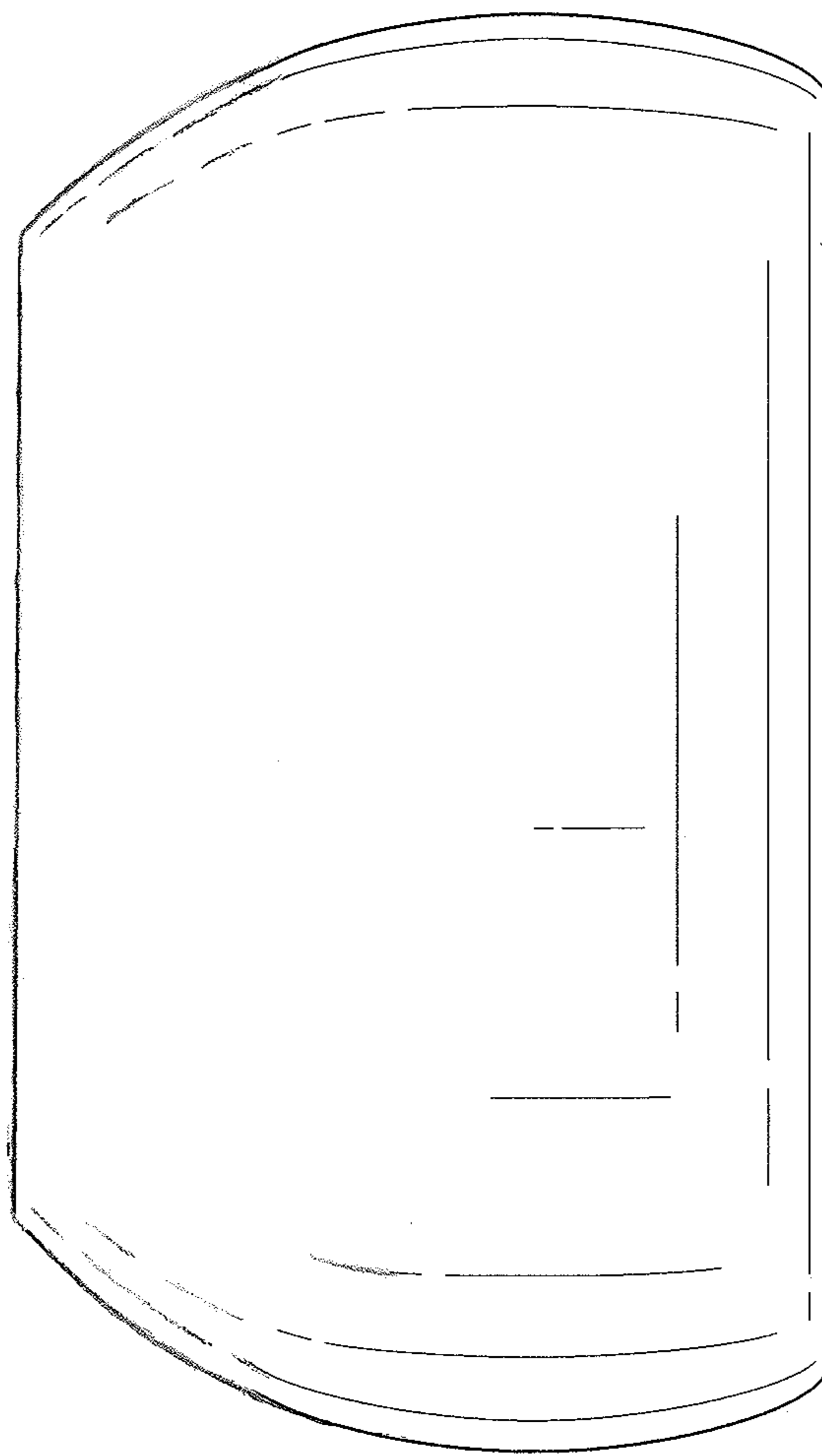

FIG. 4

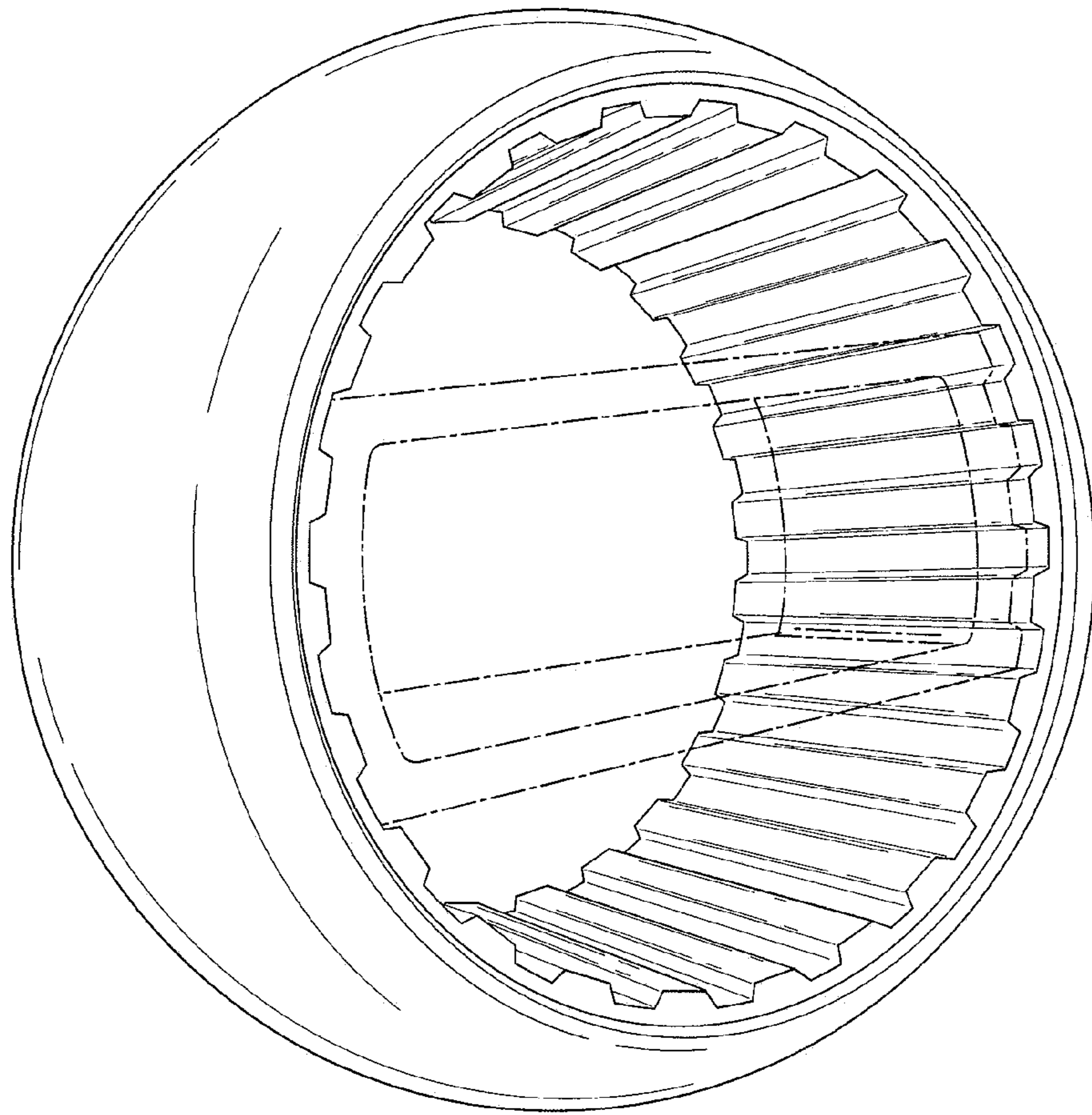

FIG. 5