

US00D765766S

(12) **United States Design Patent** (10) **Patent No.:** **US D765,766 S**  
**Steinberger** (45) **Date of Patent:** **\*\* Sep. 6, 2016**

(54) **SOUND HOLE TUNER FOR A STRINGED MUSICAL INSTRUMENT**

(71) Applicant: **D'Addario & Company, Inc.**, Farmingdale, NY (US)

(72) Inventor: **Richard Ned Steinberger**, Nobleboro, ME (US)

(73) Assignee: **D'Addario & Company, Inc.**, Farmingdale, NY (US)

(\*\*) Term: **15 Years**

(21) Appl. No.: **29/539,881**

(22) Filed: **Sep. 18, 2015**

(51) **LOC (10) Cl.** ..... **17-99**

(52) **U.S. Cl.**  
USPC ..... **D17/99**

(58) **Field of Classification Search**  
USPC ..... D8/48, 49, 313; D15/128; D17/17, 20, D17/21, 24, 99  
CPC ..... G10D 3/00; G10D 3/003; G10D 3/006; G10G 7/00; G10G 7/005  
See application file for complete search history.

(56) **References Cited**

**U.S. PATENT DOCUMENTS**

D60,105 S \* 12/1921 Polzer ..... D8/49  
D364,411 S \* 11/1995 Wang ..... D15/128  
D488,052 S \* 4/2004 Hansen ..... D8/306  
D497,935 S \* 11/2004 Kamijima ..... D17/22

D529,094 S \* 9/2006 Weng ..... D19/72  
D541,129 S \* 4/2007 Helton ..... D8/301  
D564,013 S \* 3/2008 Patton ..... D17/99  
D583,393 S \* 12/2008 Chan ..... D15/128  
D592,685 S \* 5/2009 Ferry ..... D15/128  
D635,426 S \* 4/2011 Lau ..... D8/49  
D648,394 S \* 11/2011 Yuan ..... D19/72  
D673,209 S \* 12/2012 Reboul ..... D17/20  
2014/0033896 A1 \* 2/2014 Steinhauser ..... F16M 11/10 84/421

\* cited by examiner

*Primary Examiner* — Susan E Krakower

*Assistant Examiner* — Lisa A Grabenstetter

(74) *Attorney, Agent, or Firm* — Law Offices of Daniel A. Tesler, LLC

(57) **CLAIM**

The ornamental design for a sound hole tuner for a stringed musical instrument, as shown and described.

**DESCRIPTION**

FIG. 1 is a perspective view of the sound hole tuner for a stringed musical instrument, showing my new design; FIG. 2 is a front view thereof; FIG. 3 is a bottom plan view thereof; FIG. 4 is a top plan view thereof; FIG. 6 is a side view thereof; and, FIG. 7 is an opposite side view thereof. The broken line portions are included to show unclaimed subject matter only and form no part of the claimed design.

**1 Claim, 4 Drawing Sheets**

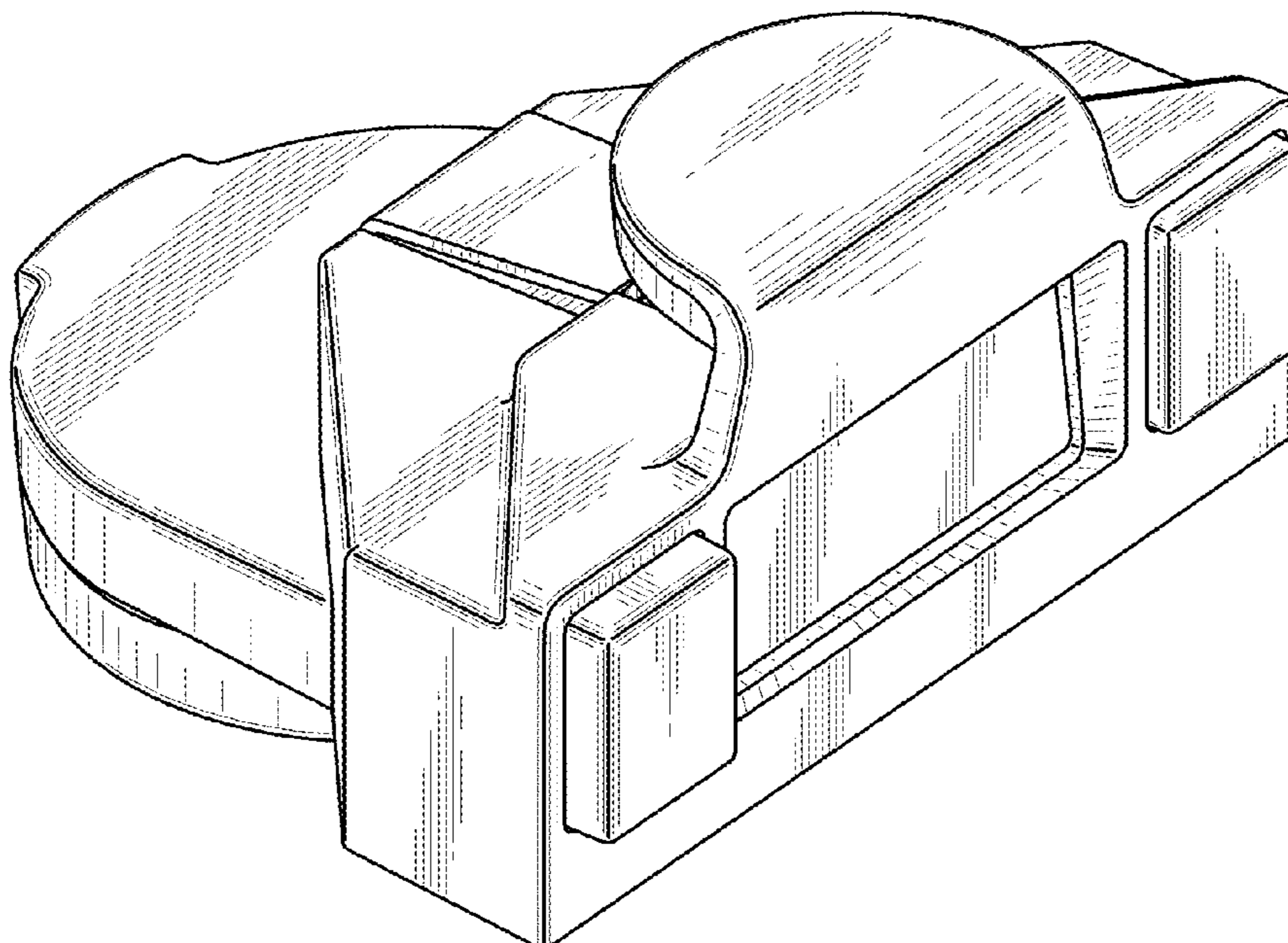

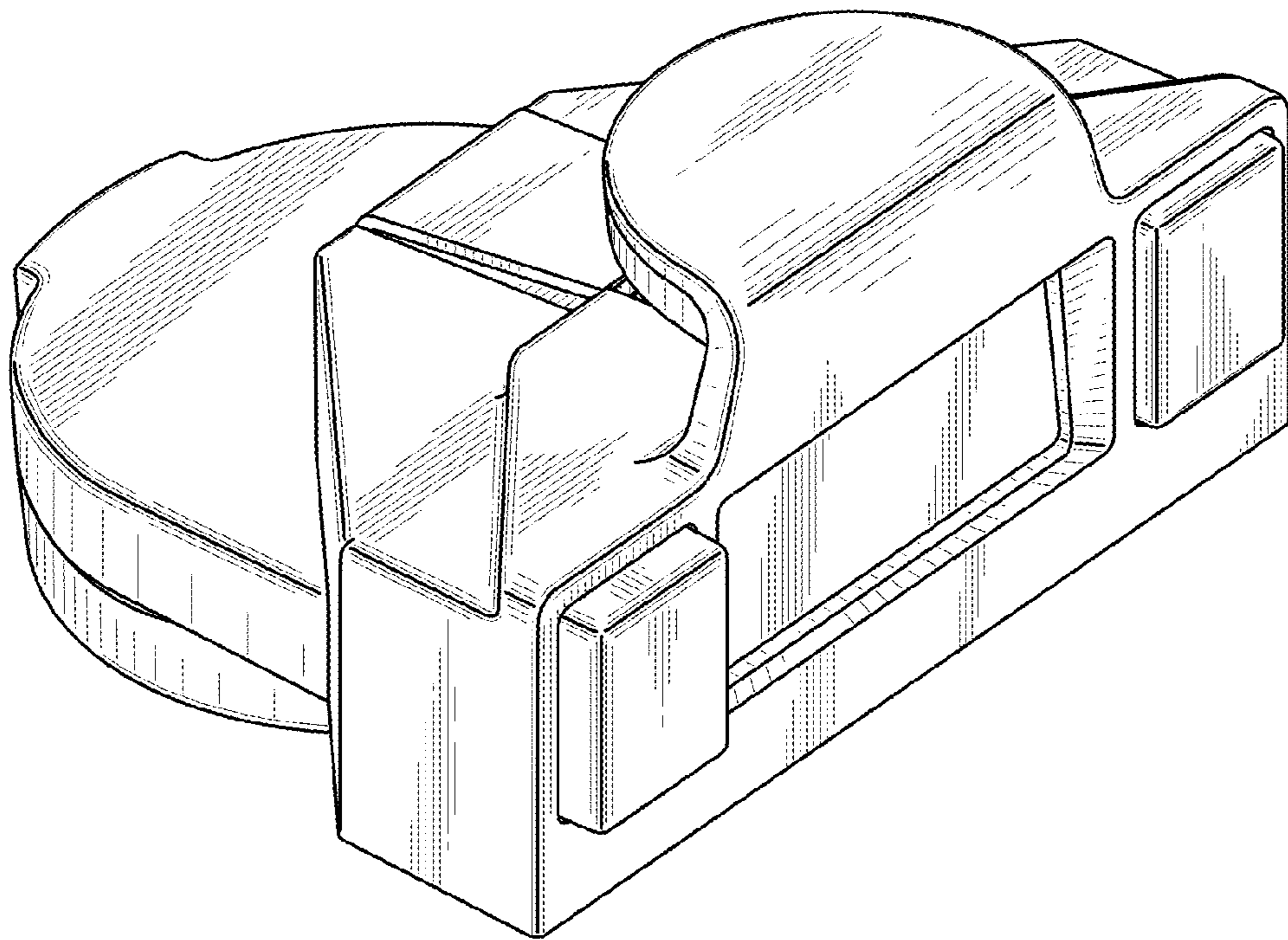

FIG. 1

FIG. 2

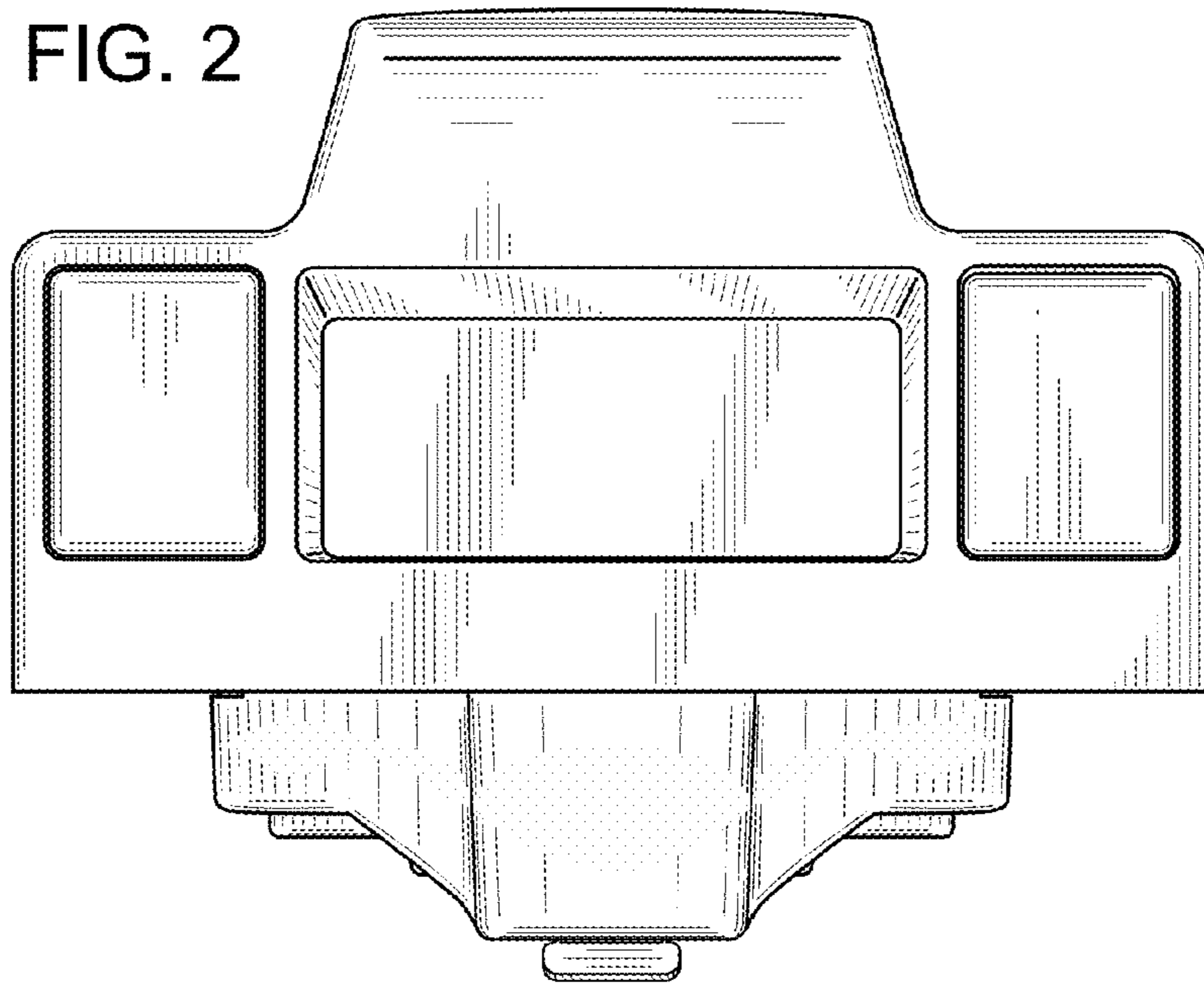

FIG. 3

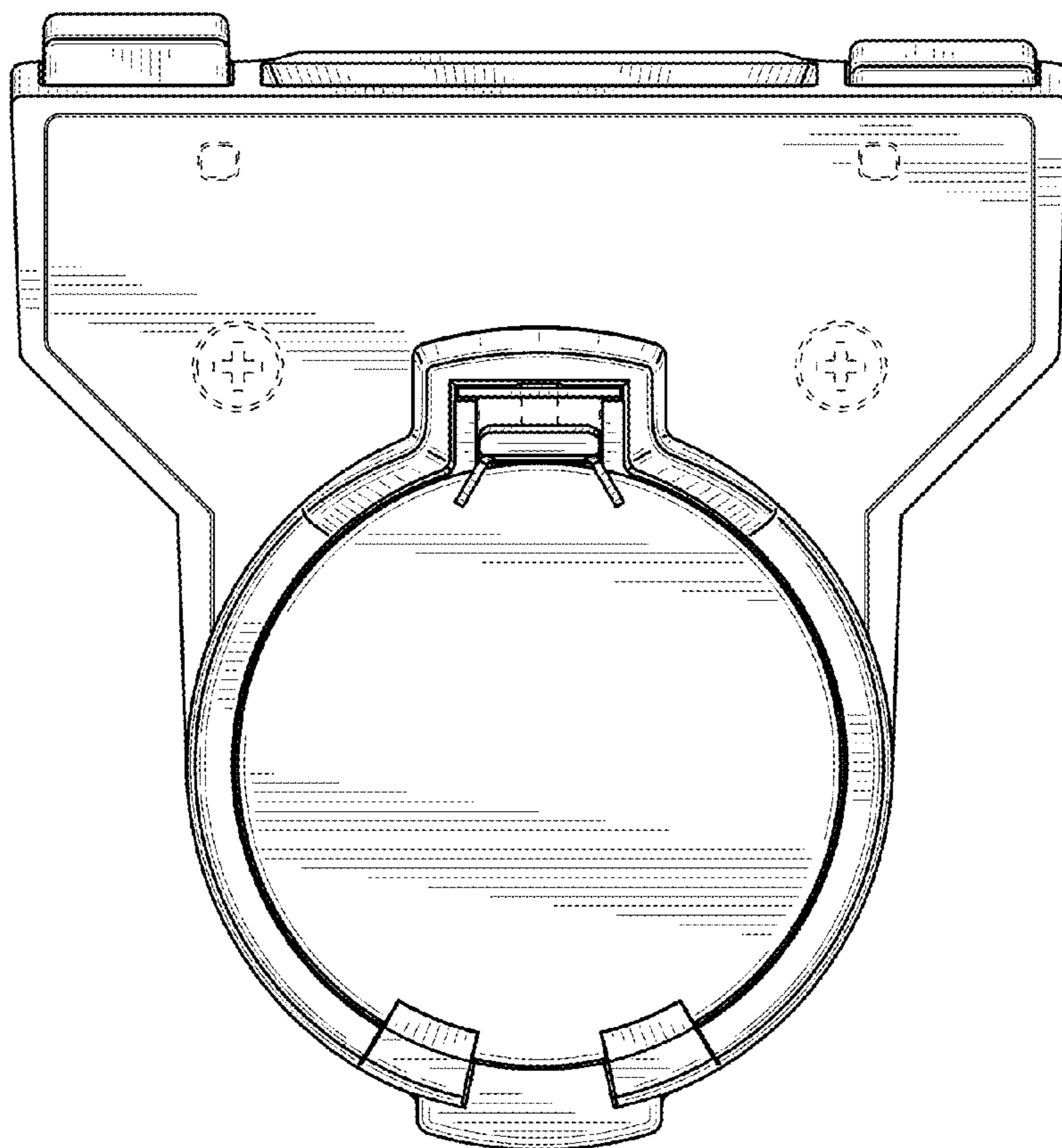



FIG. 4

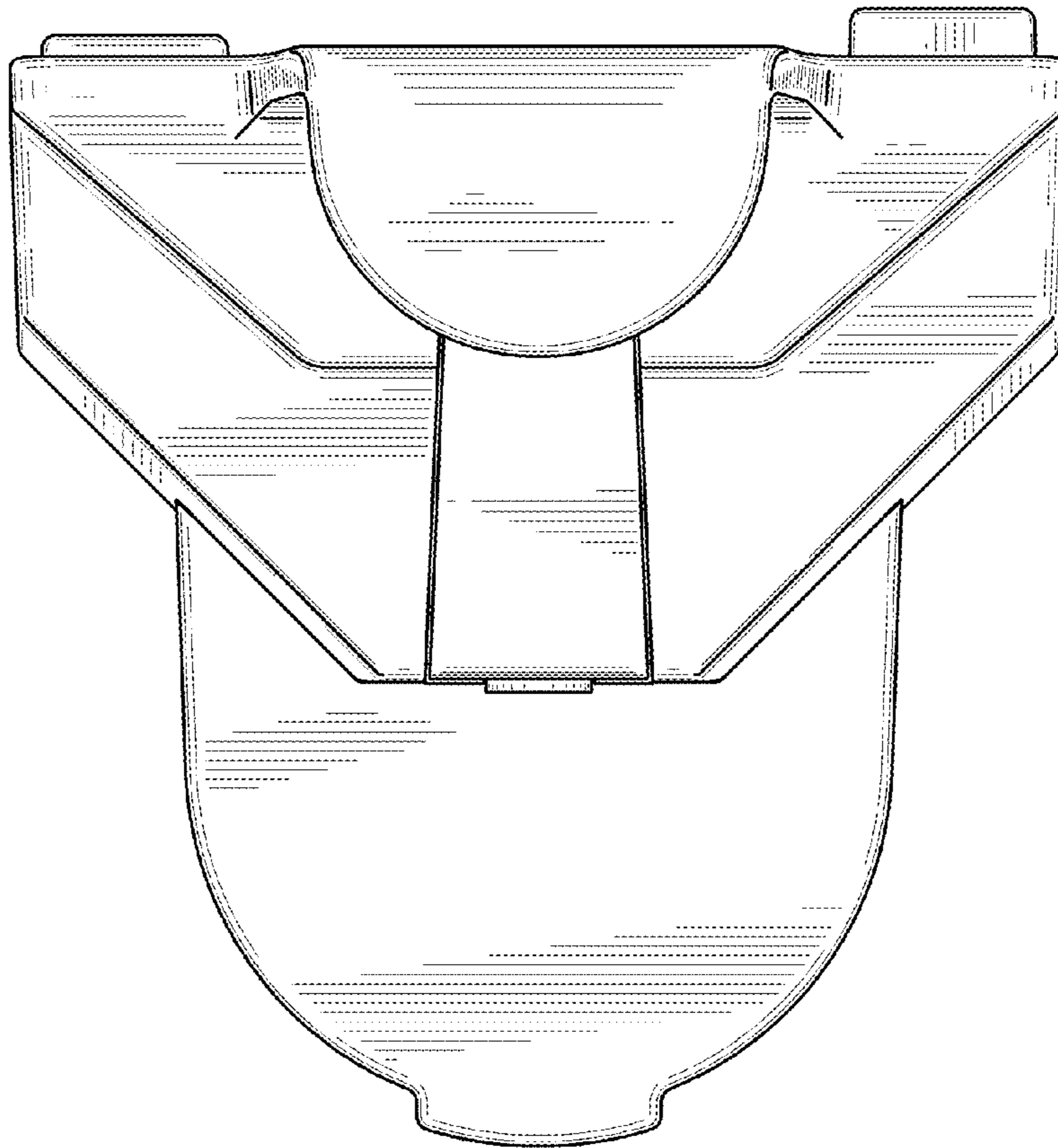

FIG. 5

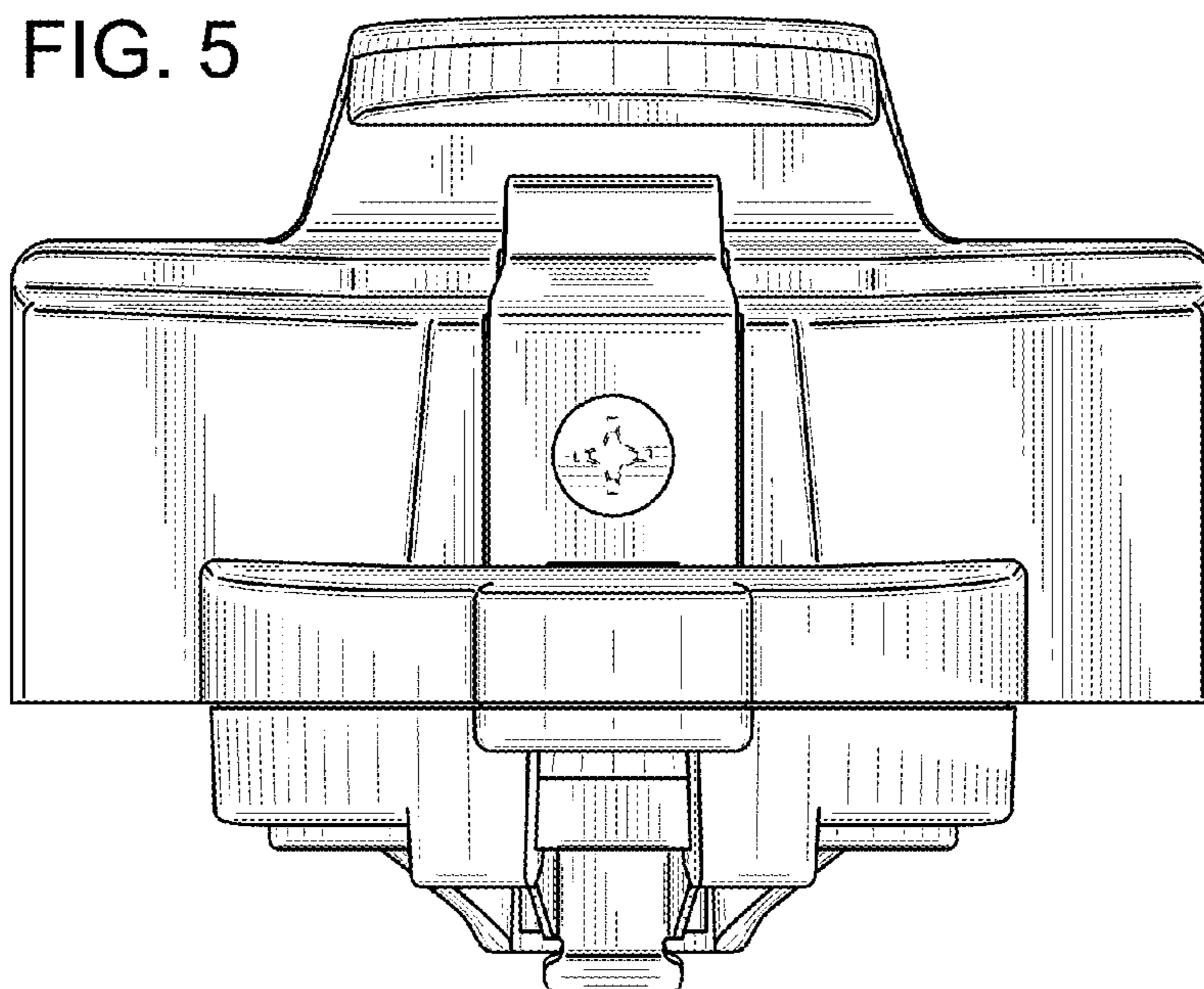

FIG. 6

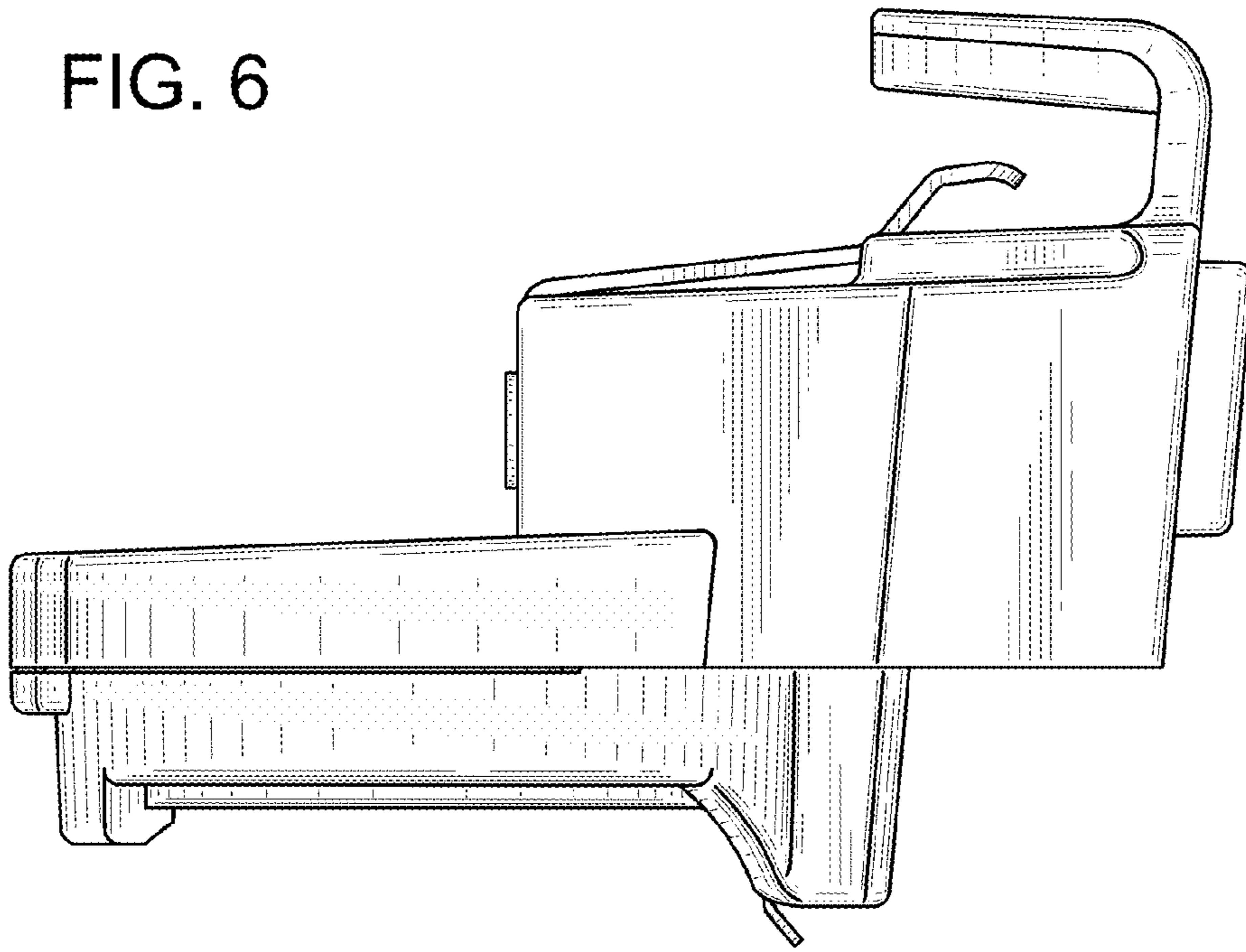

FIG. 7

