



US00D765735S

(12) **United States Design Patent**
Roemer et al.

(10) **Patent No.:** **US D765,735 S**

(45) **Date of Patent:** **** Sep. 6, 2016**

(54) **ROAD ROLLER**

(71) Applicant: **HAMM AG**, Tirschenreuth (DE)

(72) Inventors: **Axel Roemer**, Tirschenreuth (DE);
Detlef Bornemann, Tirschenreuth (DE);
Ulrich Ewringmann, Taufkirchen (DE);
Boris Eickhoff, Taufkirchen (DE)

(73) Assignee: **HAMM AG**, Tirschenreuth (DE)

(**) Term: **14 Years**

(21) Appl. No.: **29/521,386**

(22) Filed: **Mar. 23, 2015**

(30) **Foreign Application Priority Data**

Sep. 24, 2014 (EM) 001421473-0004
Sep. 24, 2014 (EM) 001421473-0005

(51) **LOC (10) Cl.** **15-03**

(52) **U.S. Cl.**
USPC **D15/20**

(58) **Field of Classification Search**
USPC D15/10, 20, 22-26, 28; 280/104,
280/124.11; 180/20, 89.12; 404/122, 132,
404/125, 90
CPC E02D 3/026; E02D 3/00; B30B 15/00
See application file for complete search history.

(56) **References Cited**

U.S. PATENT DOCUMENTS

D396,431 S * 7/1998 Lindgren D12/14
D516,094 S * 2/2006 Dotsch D15/20
D589,067 S * 3/2009 Yamamoto D15/20
D611,505 S * 3/2010 Loew D15/20
D611,506 S * 3/2010 Loew D15/20
D657,397 S * 4/2012 Loew D15/20

8,376,655 B2 * 2/2013 Marsolek E01C 19/26
404/103
D694,278 S * 11/2013 Ewringmann D15/20
D694,279 S * 11/2013 Ewringmann D15/20
D699,764 S * 2/2014 Loew D15/20
D744,543 S * 12/2015 Loew D15/20
D745,063 S * 12/2015 Loew D15/20
D749,142 S * 2/2016 Erdmann D15/20
D749,143 S * 2/2016 Erdmann D15/20

* cited by examiner

Primary Examiner — Mark Goodwin

(74) *Attorney, Agent, or Firm* — Greer, Burns & Crain, Ltd.

(57) **CLAIM**

The ornamental design for road roller, as shown and described.

DESCRIPTION

FIG. 1 is a top front perspective view of the present road roller;
FIG. 2 is a top rear perspective view of same;
FIG. 3 is a front view of the present road roller;
FIG. 4 is a rear view of same;
FIG. 5 is a left side view of the present road roller;
FIG. 6 is a right side view of same;
FIG. 7 is a top view of the present road roller;
FIG. 8 is a top front perspective view of a second embodiment of the present road roller;
FIG. 9 is a top rear perspective view of the road roller of FIG. 8;
FIG. 10 is a front view of same;
FIG. 11 is a rear view of the road roller of FIG. 8;
FIG. 12 is a left side view of same;
FIG. 13 is a right side view of same; and,
FIG. 14 is a top view of same.
The structure shown in broken lines is for environment purposes only and does not form part of the claimed invention.

1 Claim, 14 Drawing Sheets

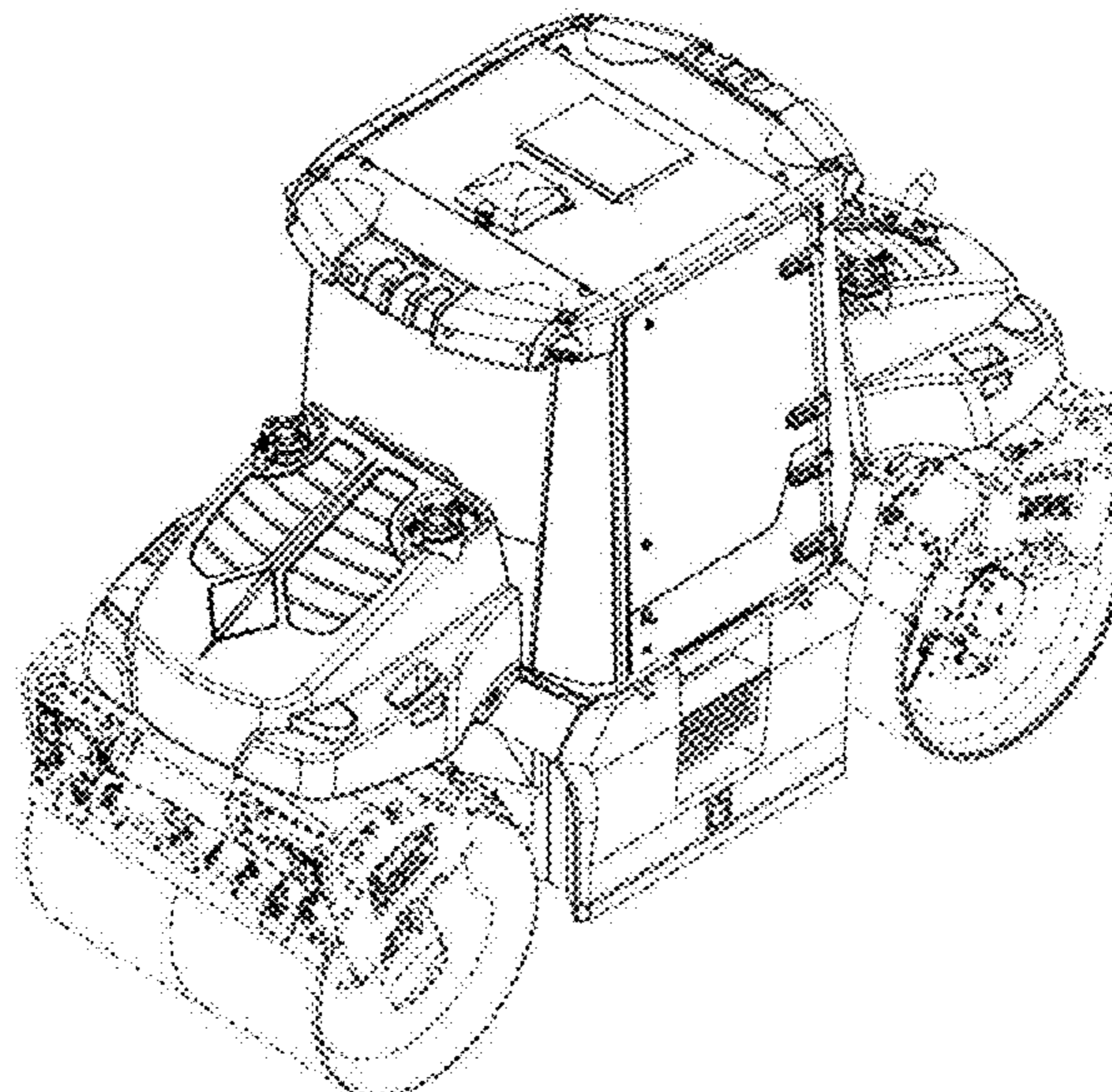

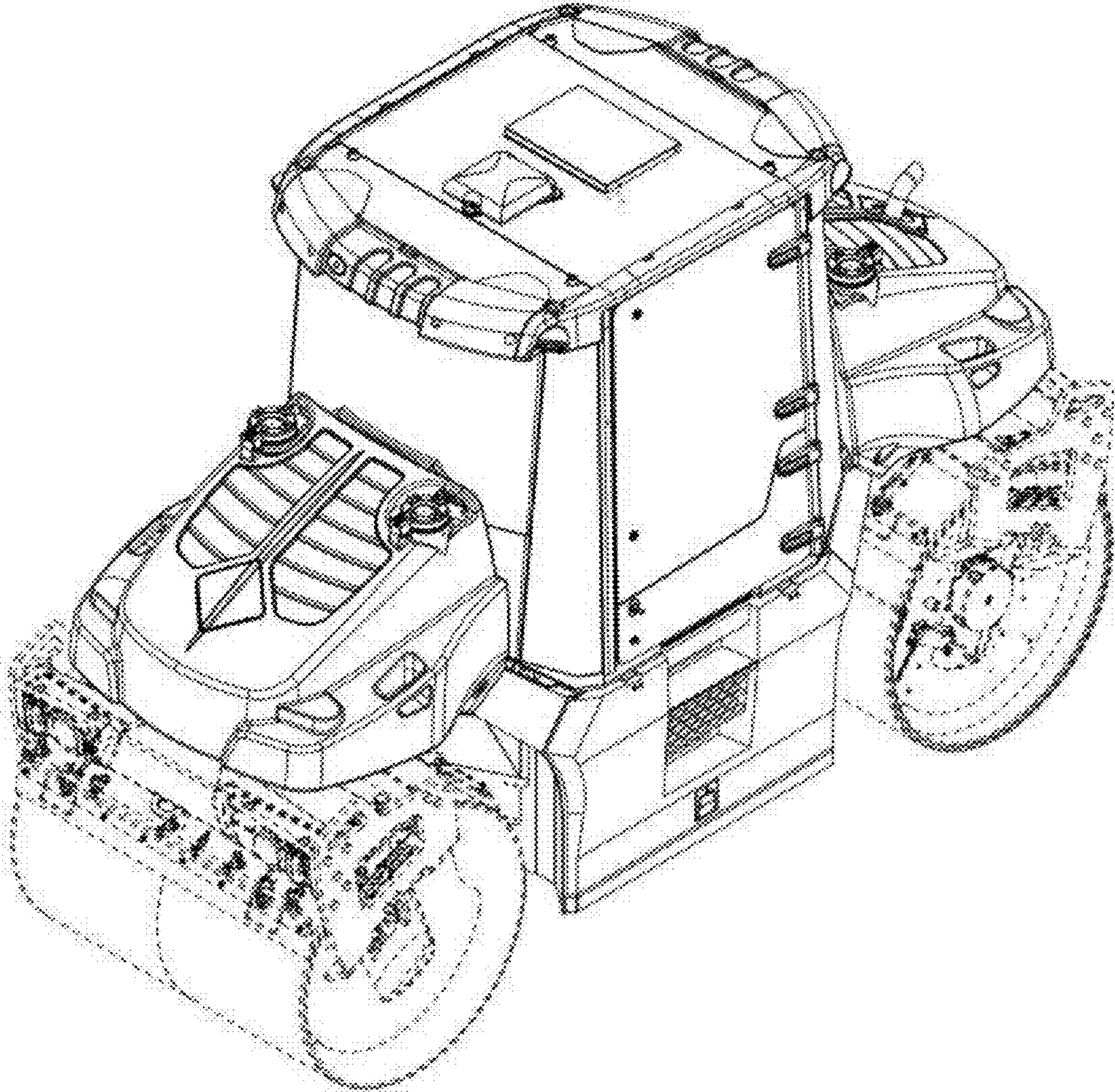

FIG. 1

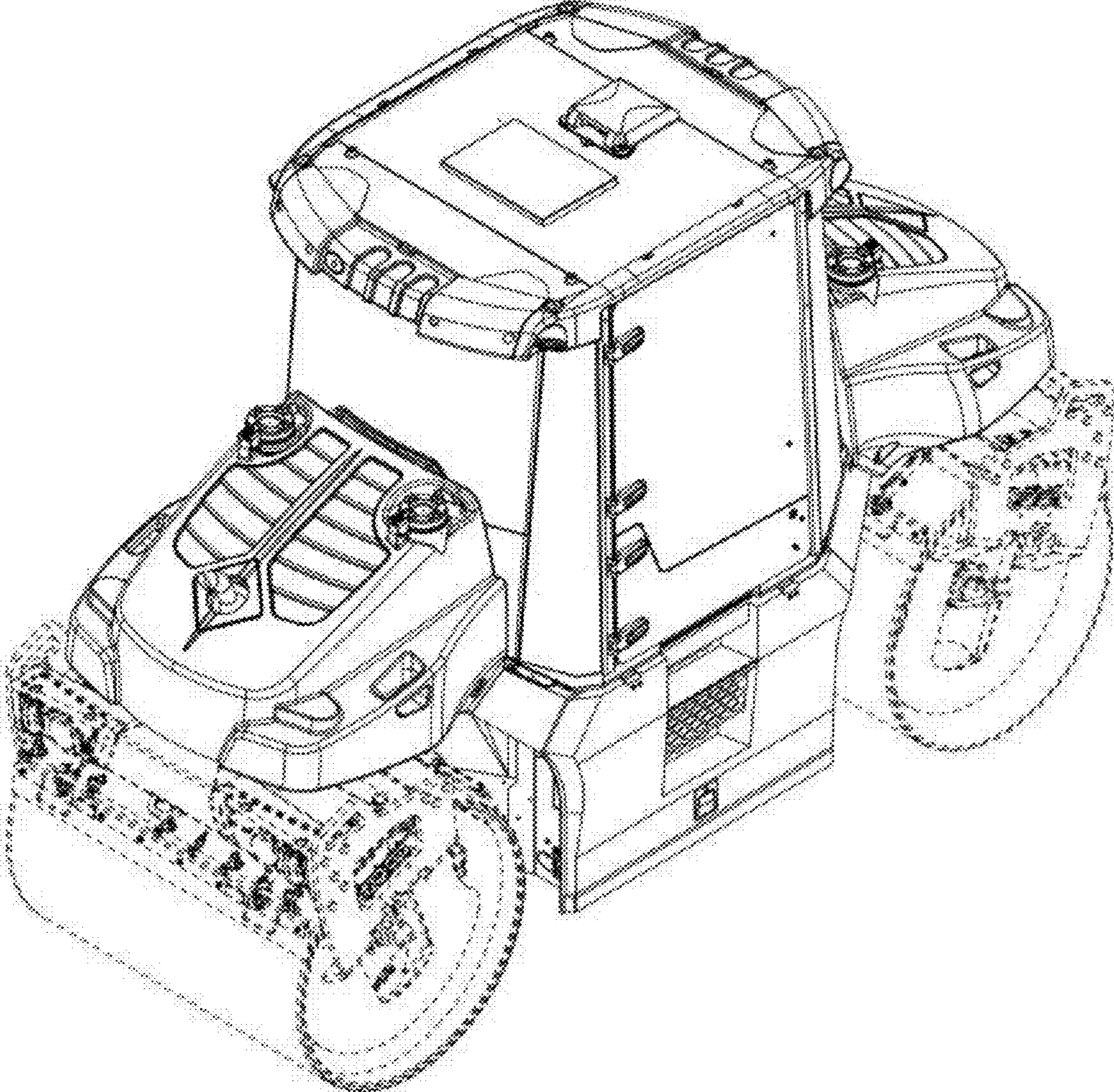

FIG. 2

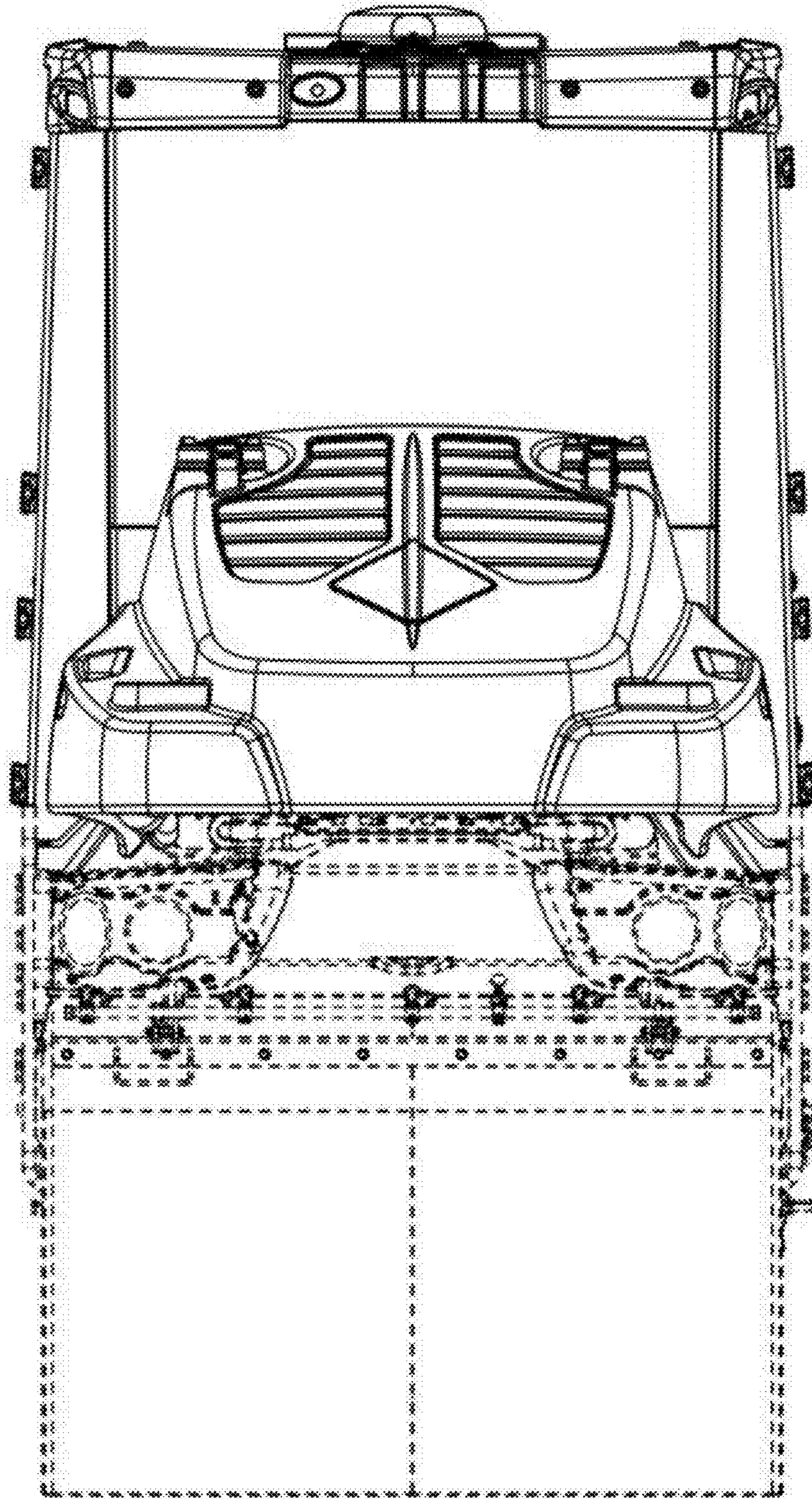

FIG. 3

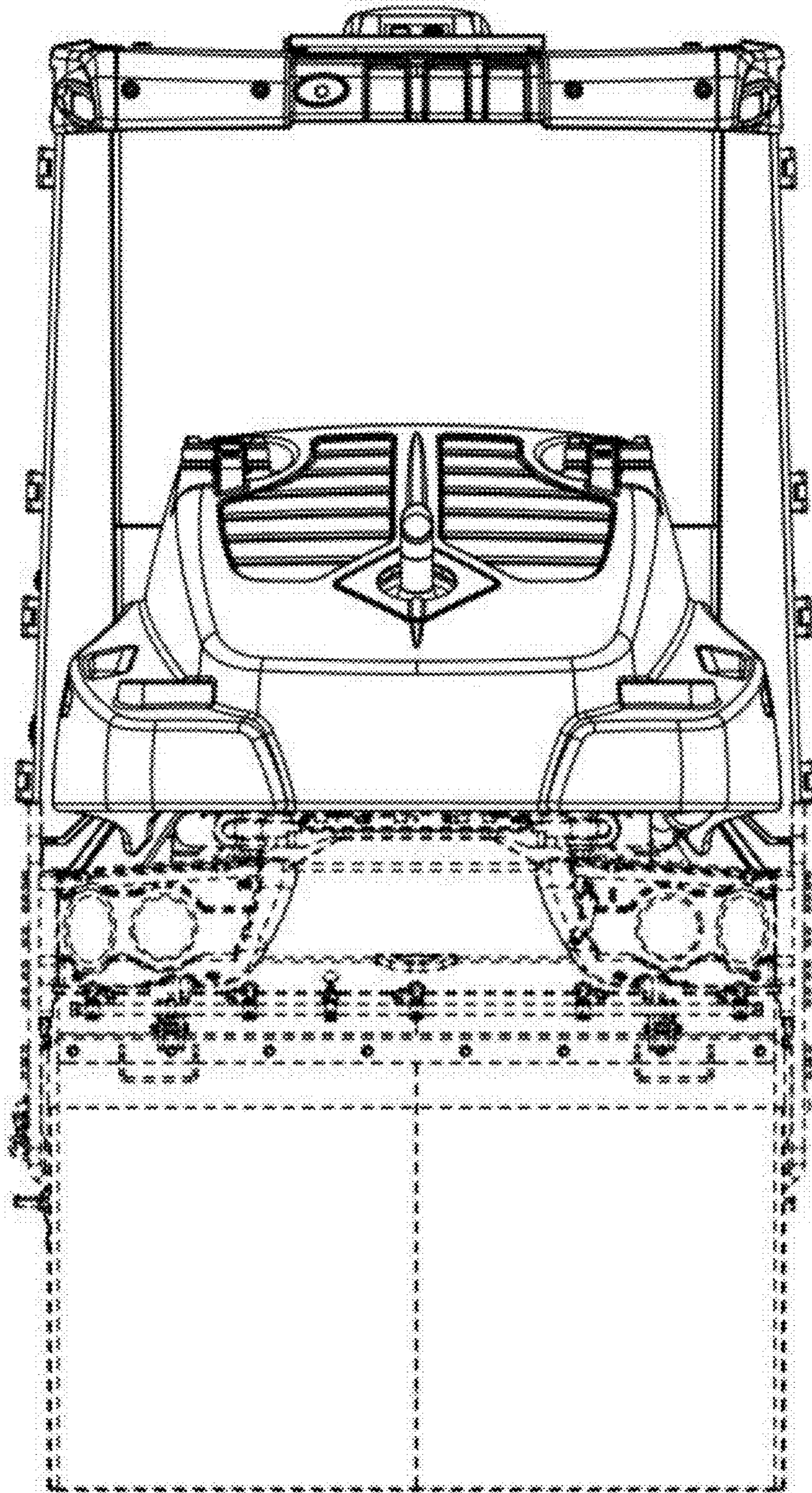

FIG. 4

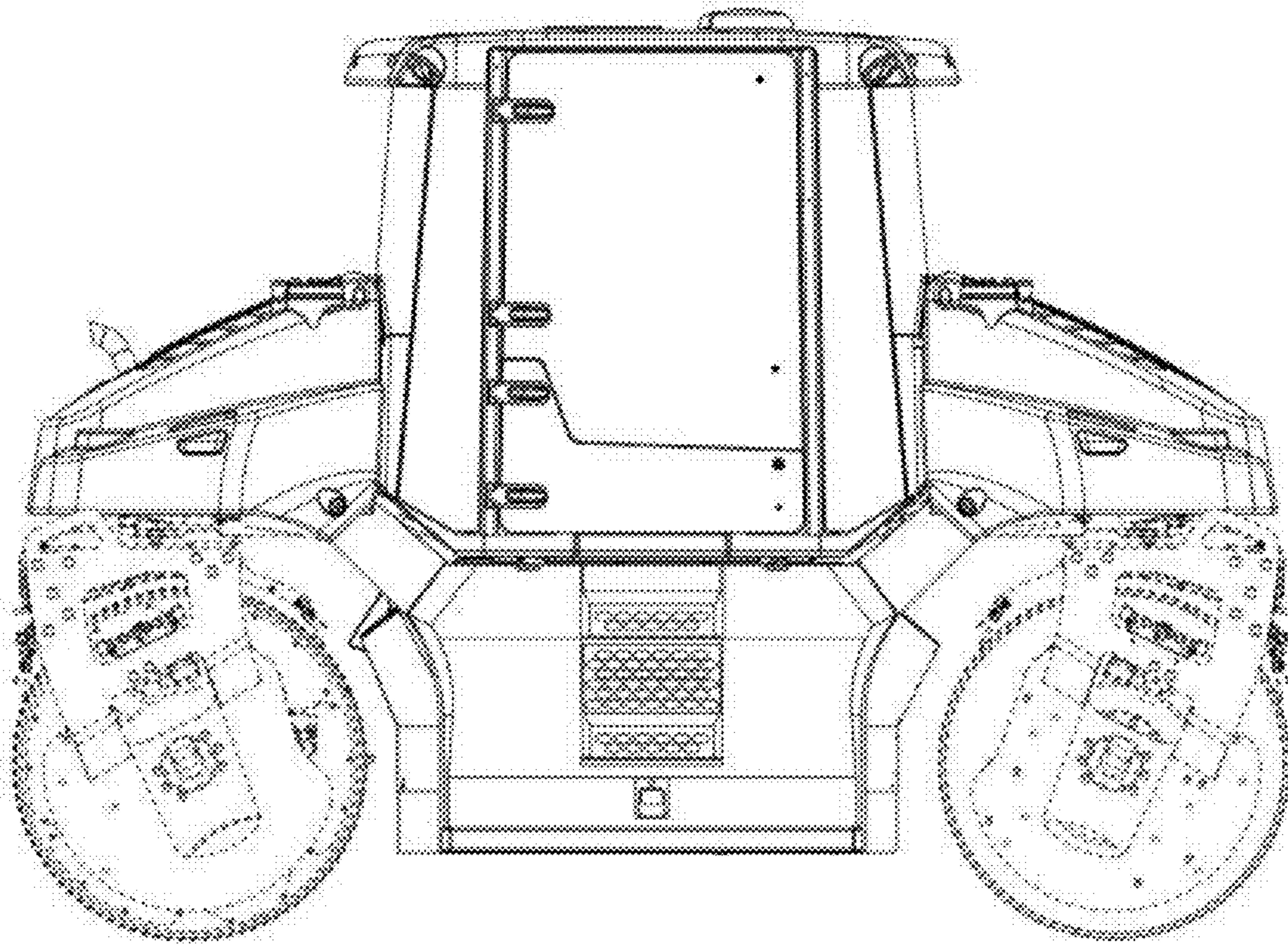

FIG. 5

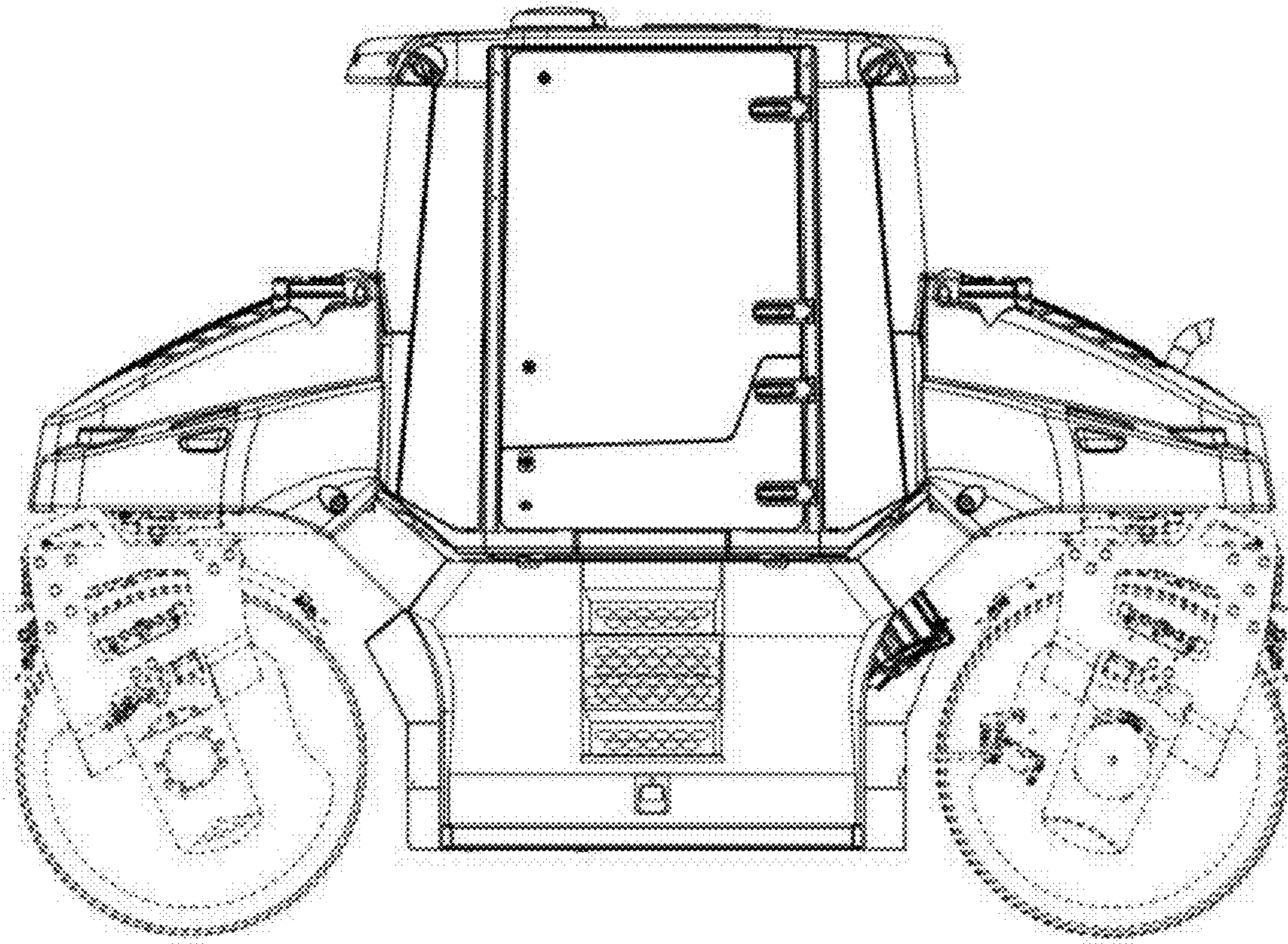

FIG. 6

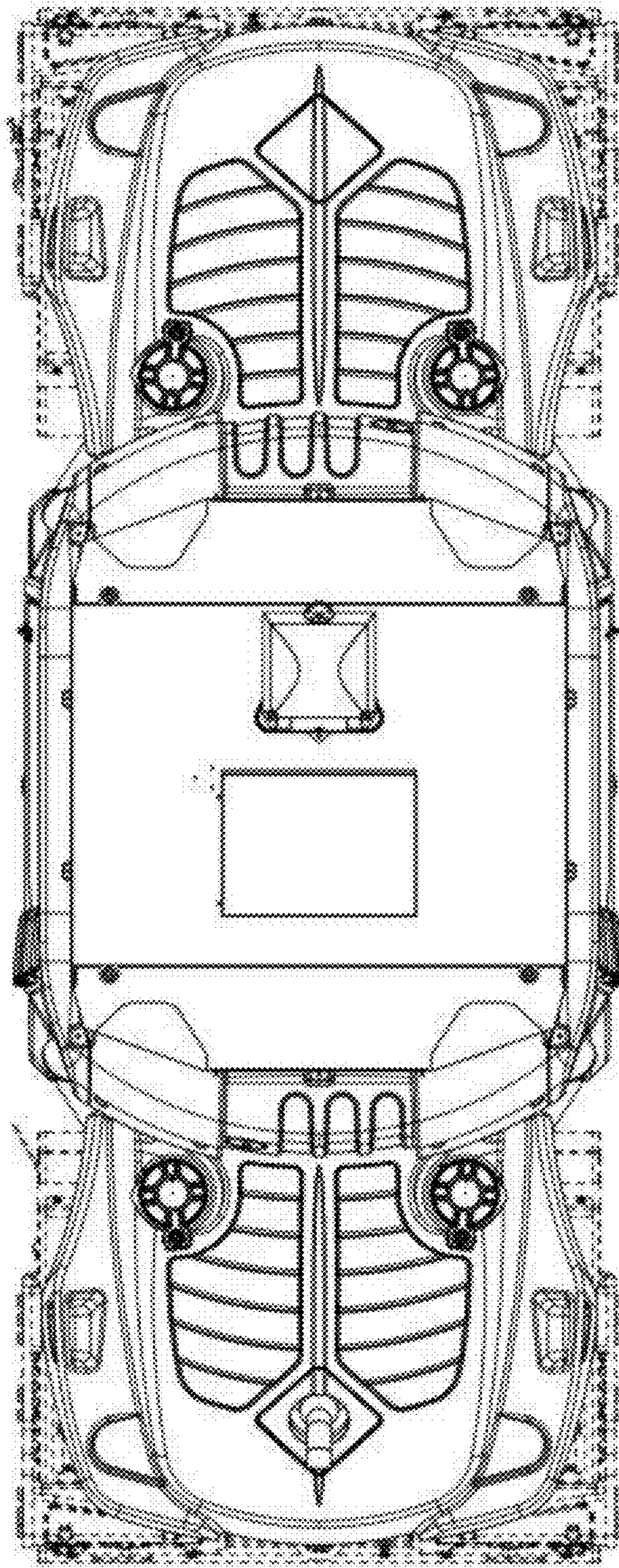

FIG. 7

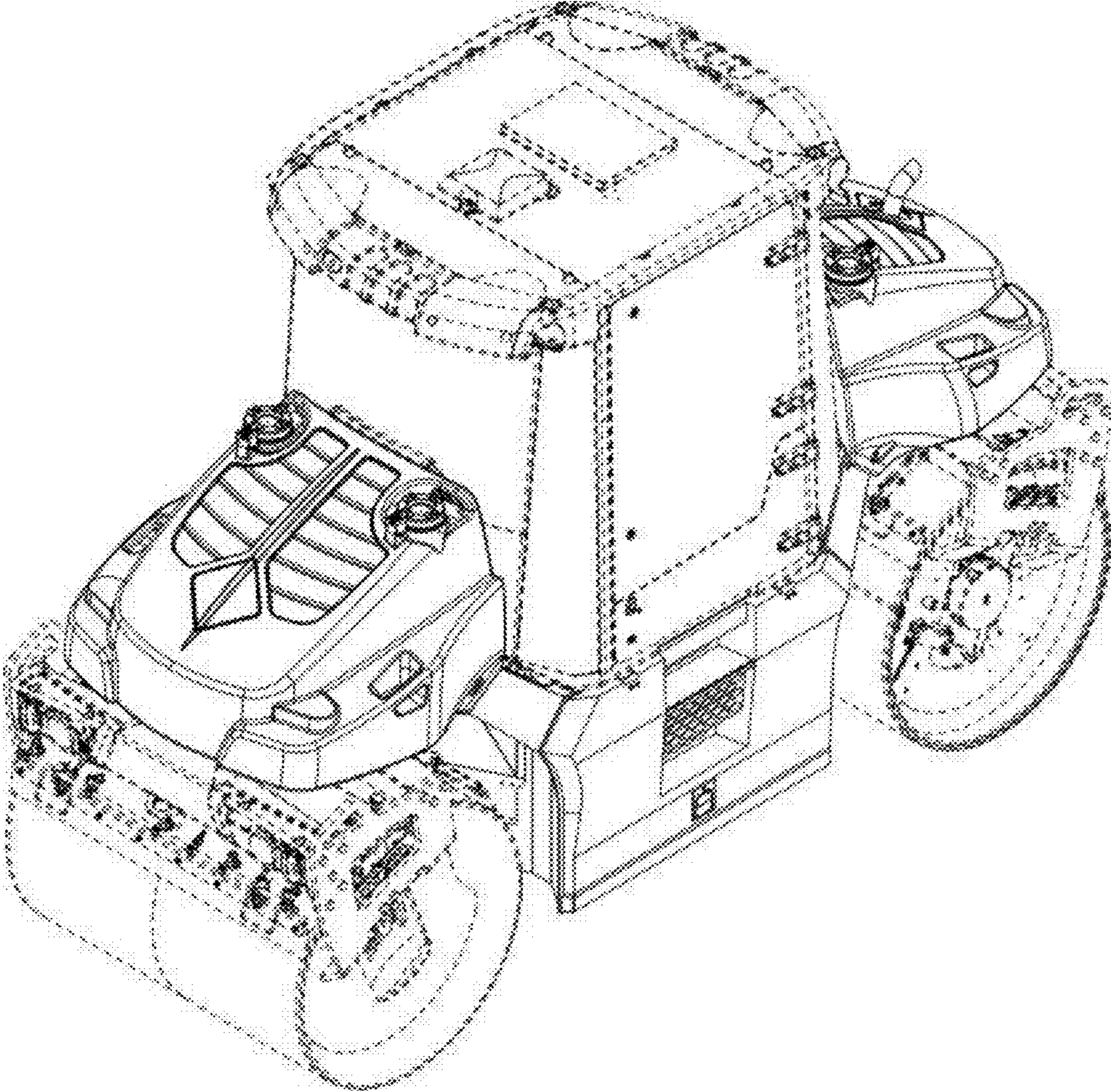

FIG. 8

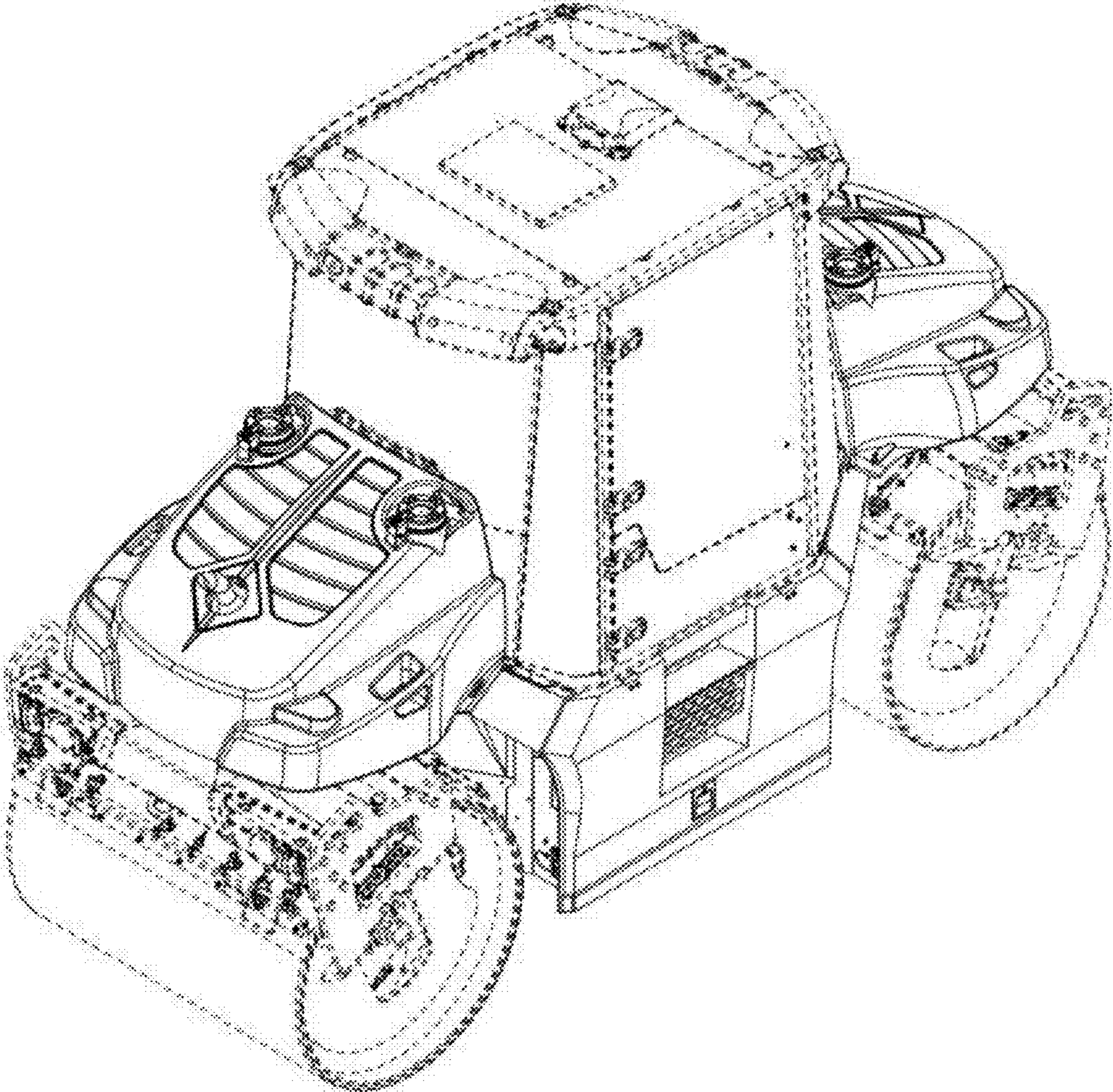

FIG. 9

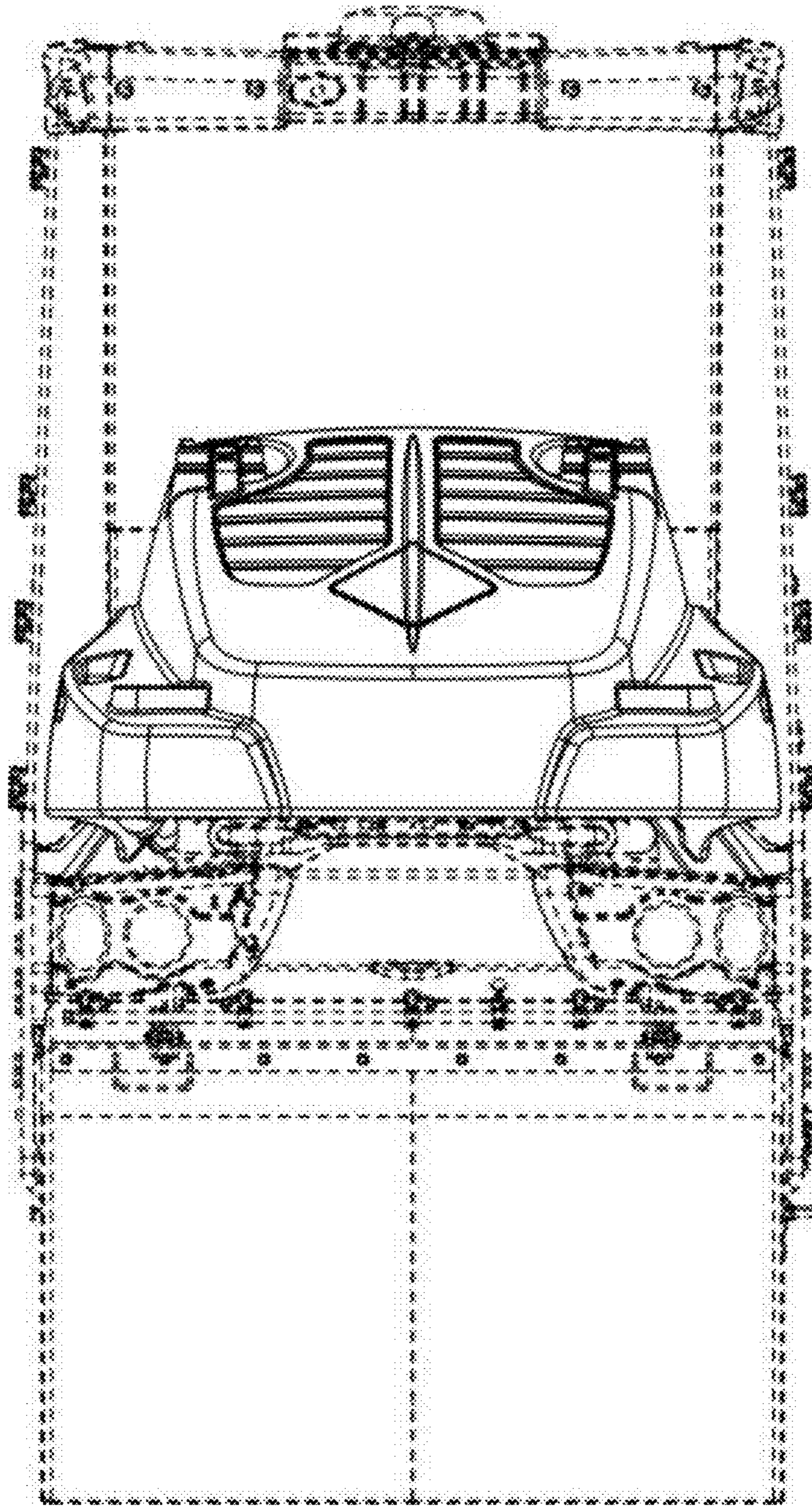

FIG. 10

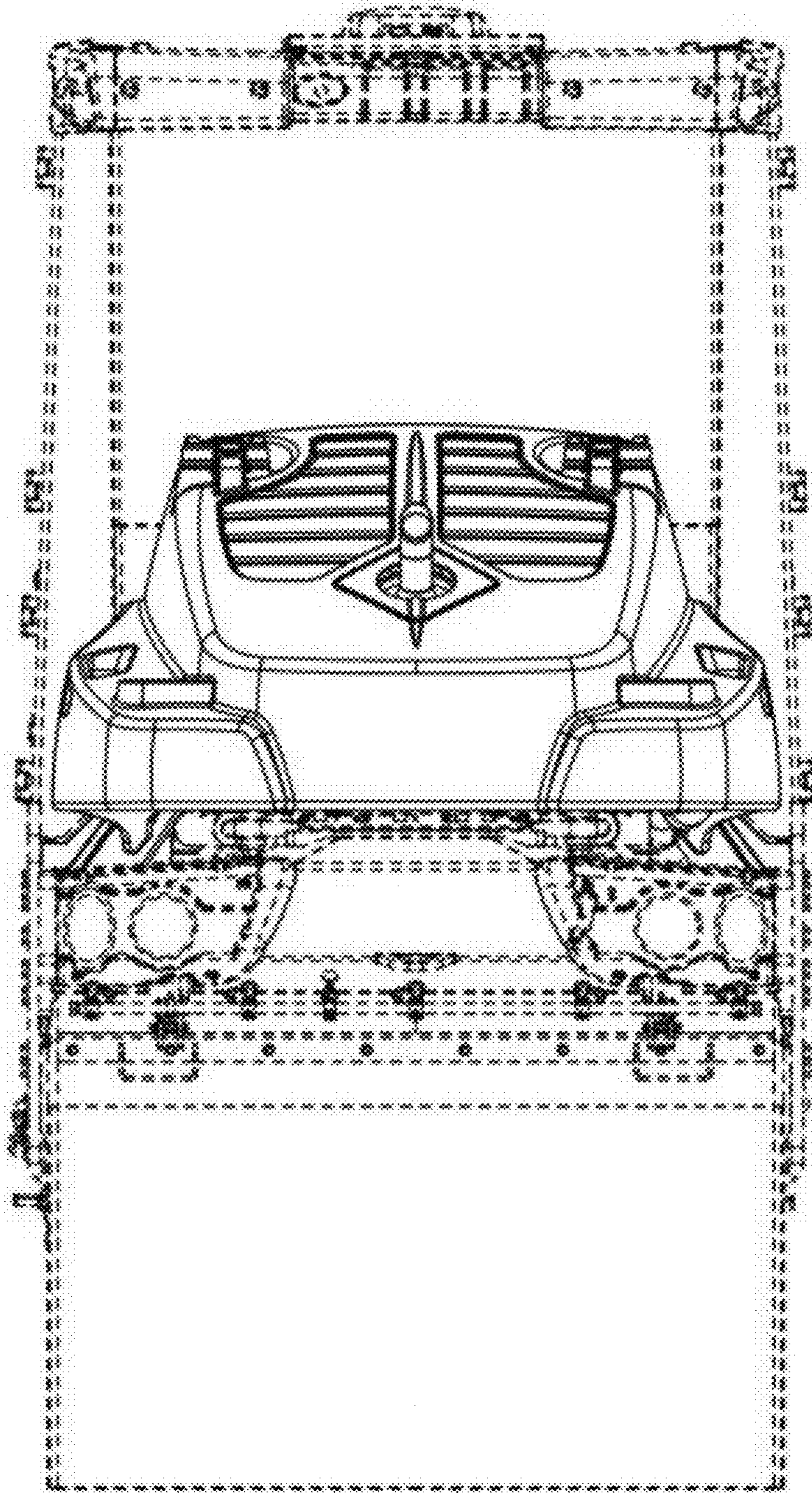

FIG. 11

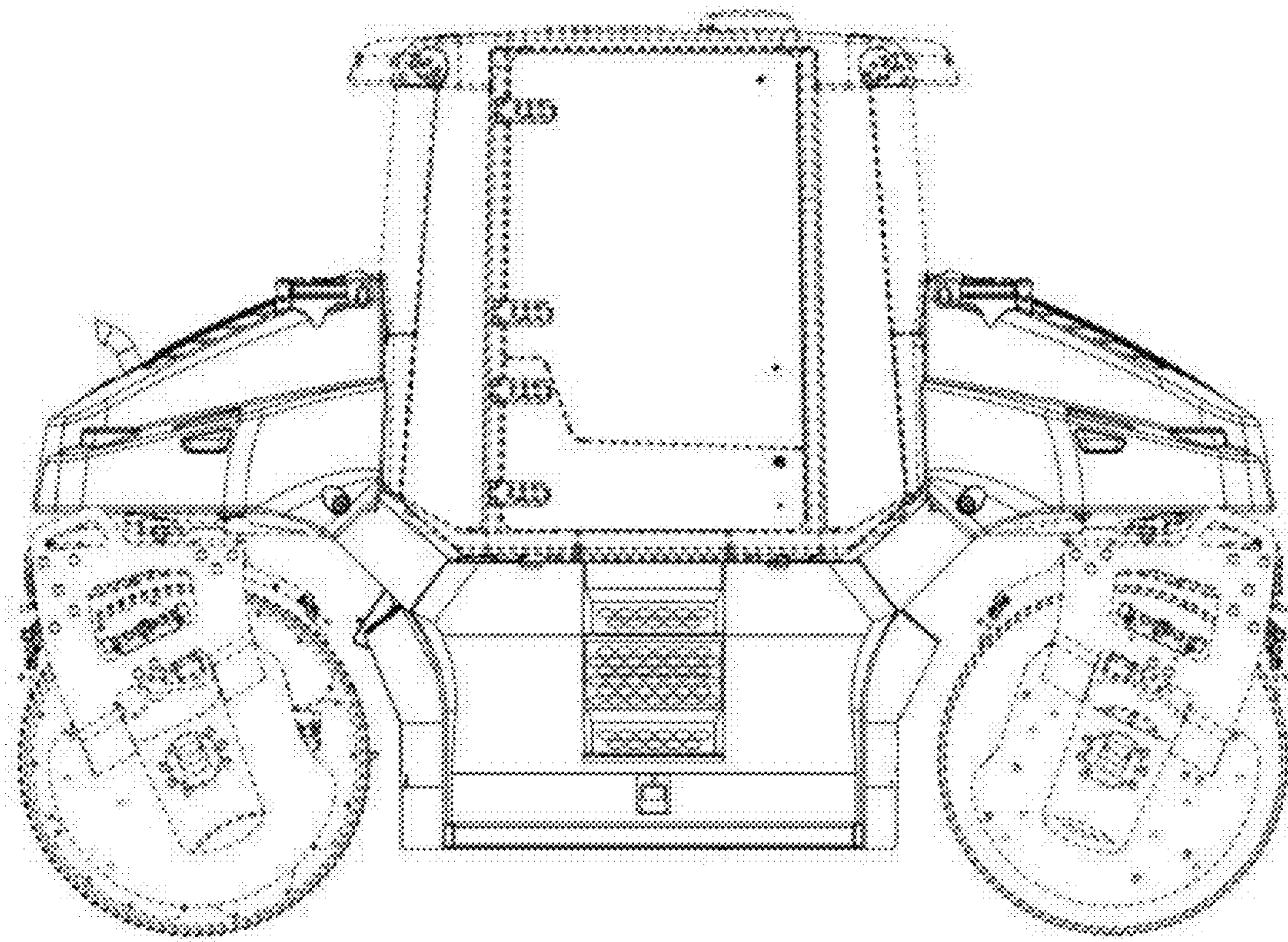

FIG. 12

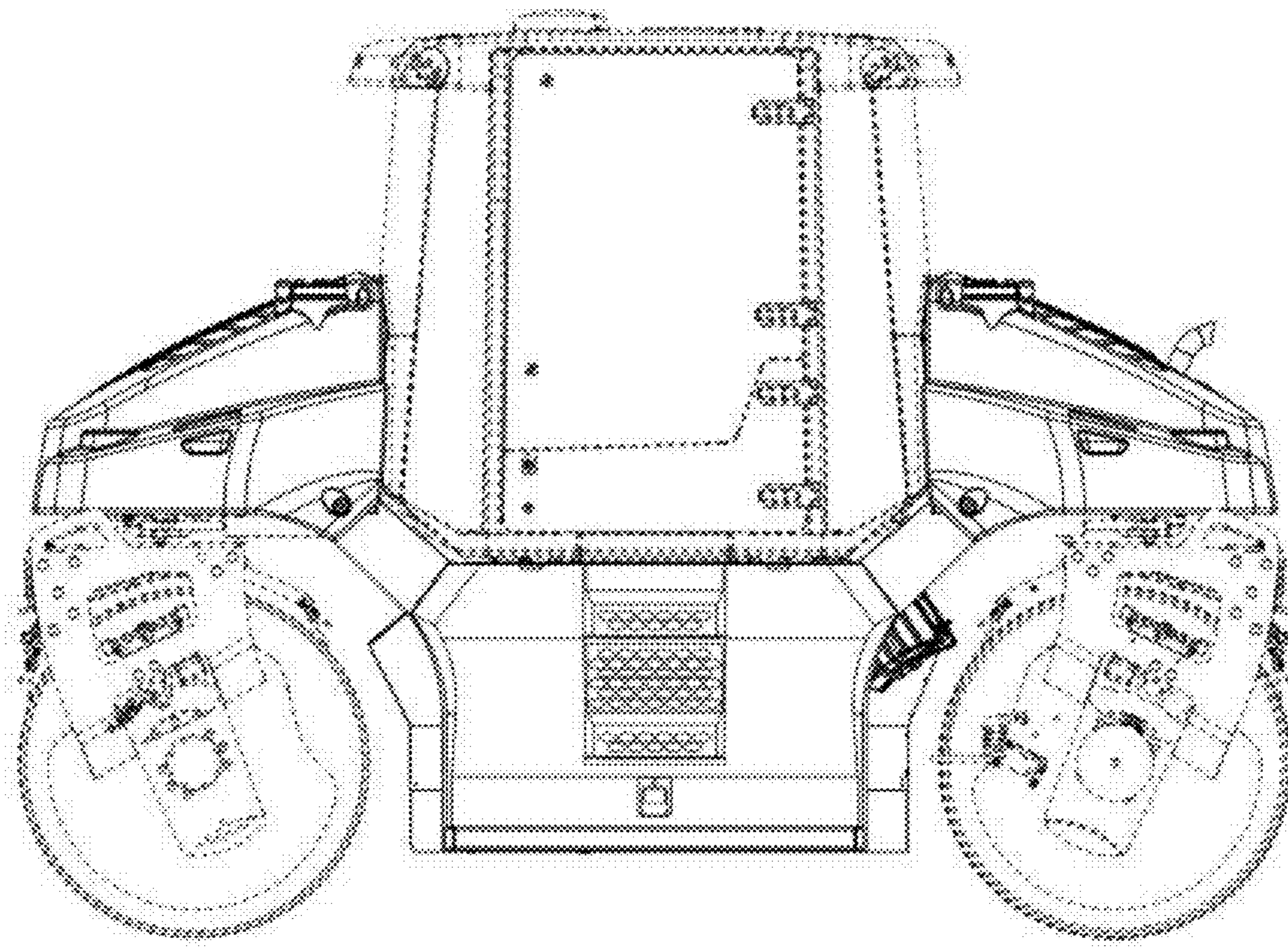

FIG. 13

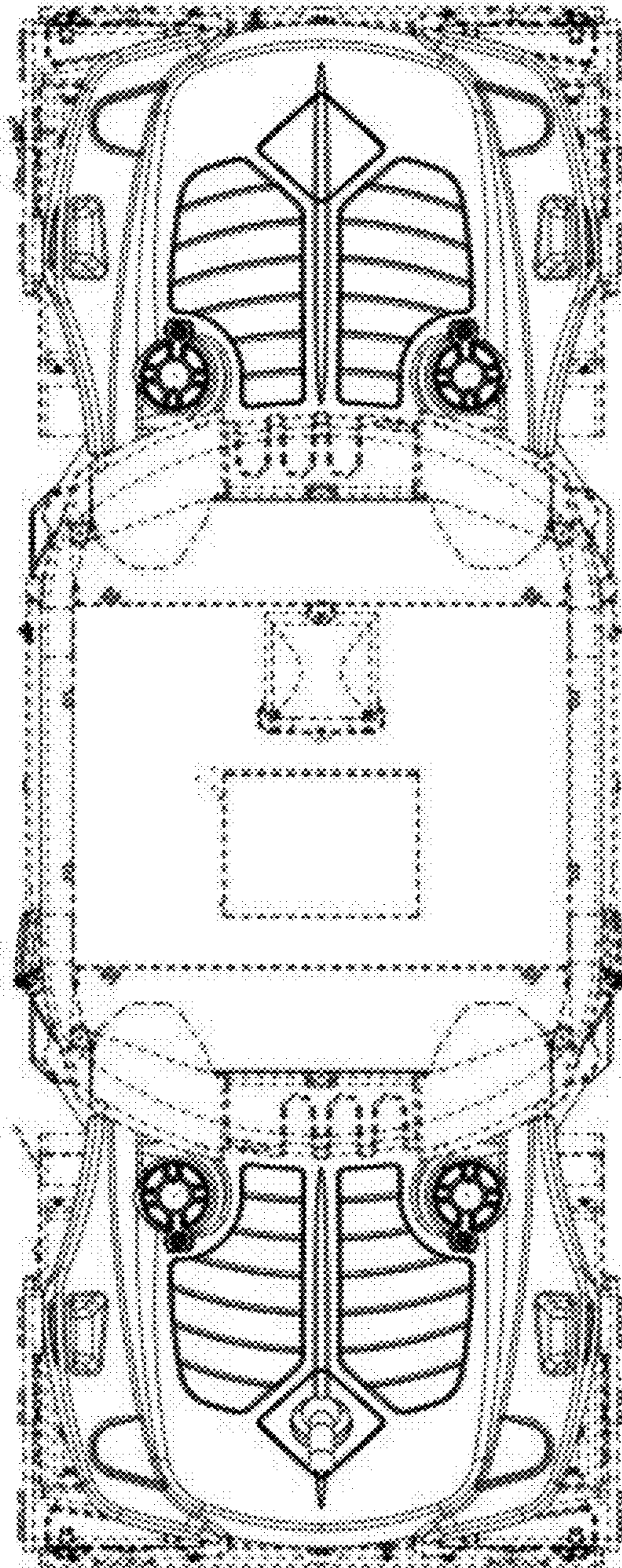

FIG. 14

UNITED STATES PATENT AND TRADEMARK OFFICE
CERTIFICATE OF CORRECTION

PATENT NO. : D765,735 S
APPLICATION NO. : 29/521386
DATED : September 6, 2016
INVENTOR(S) : Axel Römer et al.

Page 1 of 1

It is certified that error appears in the above-identified patent and that said Letters Patent is hereby corrected as shown below:

On the Title Page

Under DESCRIPTION, please change to read as follows:

FIG. 1 is a top front perspective view of the present road roller;

FIG. 2 is a top rear perspective view of same;

FIG. 3 is a front view of the present road roller;

FIG. 4 is a rear view of same;

FIG. 5 is a left side view of the present road roller;

FIG. 6 is a right side view of same; and

FIG. 7 is a top view of the present road roller.

The structure shown in broken lines is for environment purposes only and does not form part of the claimed invention.

Please delete "1 Claim, 14 Drawing Sheets" and insert -- 1 Claim, 7 Drawing Sheets --.

In the Drawings

Please delete FIGs. 8-14.

Signed and Sealed this
Eighth Day of August, 2017



Joseph Matal
*Performing the Functions and Duties of the
Under Secretary of Commerce for Intellectual Property and
Director of the United States Patent and Trademark Office*