



US00D765143S

(12) **United States Design Patent** (10) **Patent No.:** **US D765,143 S**  
**VanderMeulen** (45) **Date of Patent:** **\*\* Aug. 30, 2016**

(54) **ENGINE HEADER**  
(71) Applicant: **Keith VanderMeulen**, Santa Maria, CA (US)  
(72) Inventor: **Keith VanderMeulen**, Santa Maria, CA (US)  
(\*\*) Term: **14 Years**  
(21) Appl. No.: **29/514,080**  
(22) Filed: **Jan. 8, 2015**  
(51) **LOC (10) Cl.** ..... **15-01**  
(52) **U.S. Cl.**  
USPC ..... **D15/5**  
(58) **Field of Classification Search**  
USPC ..... D15/5; 123/184.39, 184.41, 184.42, 123/184.44, 184.47, 184.53, 184.61, 123/184.34, 184.33, 184.21, 41.27, 41.73, 123/184.35, 184.36, 184.55, 572; 60/299, 60/302, 313, 323, 325, 324; D12/194, D12/110; 29/890.08; 285/150; 180/89.2, 180/296, 309; 181/227, 228, 239-241, 264, 181/282, 247-249  
CPC ..... F02M 35/10144; F02M 35/112; F02M 35/116; F02M 35/162; F02M 35/10039; F02M 35/10052; F02M 35/10078; F02M 35/10347; F02M 35/10334; F02M 35/10321; F02M 35/10098; F02M 35/10072; F02M 35/104; F02M 35/10085  
See application file for complete search history.

D676,460 S \* 2/2013 Grubisich ..... D15/5  
D679,288 S \* 4/2013 Grubisich ..... D15/5  
D700,556 S \* 3/2014 Glaeser ..... D12/194  
D700,558 S \* 3/2014 Glaeser ..... D12/194  
D700,559 S \* 3/2014 Glaeser ..... D12/194  
D700,560 S \* 3/2014 Glaeser ..... D12/194  
D700,561 S \* 3/2014 Glaeser ..... D12/194  
2009/0013679 A1\* 1/2009 Abe ..... F01N 13/102  
60/321  
2011/0016859 A1\* 1/2011 Schumnig ..... F01N 3/10  
60/323  
2011/0107996 A1\* 5/2011 Menin ..... F02B 31/06  
123/184.61  
2011/0315125 A1\* 12/2011 Lohr ..... F02M 35/10229  
123/519  
2015/0267597 A1\* 9/2015 Fischer ..... F01N 13/16  
60/323

\* cited by examiner

*Primary Examiner* — T. Chase Nelson  
*Assistant Examiner* — Ania Aman  
(74) *Attorney, Agent, or Firm* — Dunlap Bennett & Ludwig PLLC

(57) **CLAIM**  
The ornamental design for an engine header, as shown and described.

**DESCRIPTION**

FIG. 1 is a front perspective view of an engine header; FIG. 2 is a front elevation view thereof; FIG. 3 is a rear elevation view thereof; FIG. 4 is a left side elevation view thereof; the right side view being a mirror image thereof; FIG. 5 is a top plan view thereof; and, FIG. 6 is a bottom plan view thereof.

**1 Claim, 4 Drawing Sheets**

(56) **References Cited**  
U.S. PATENT DOCUMENTS  
D266,168 S \* 9/1982 Lindbrandt ..... D15/5  
6,553,954 B1 \* 4/2003 Stonecker ..... F02B 75/20  
123/184.21

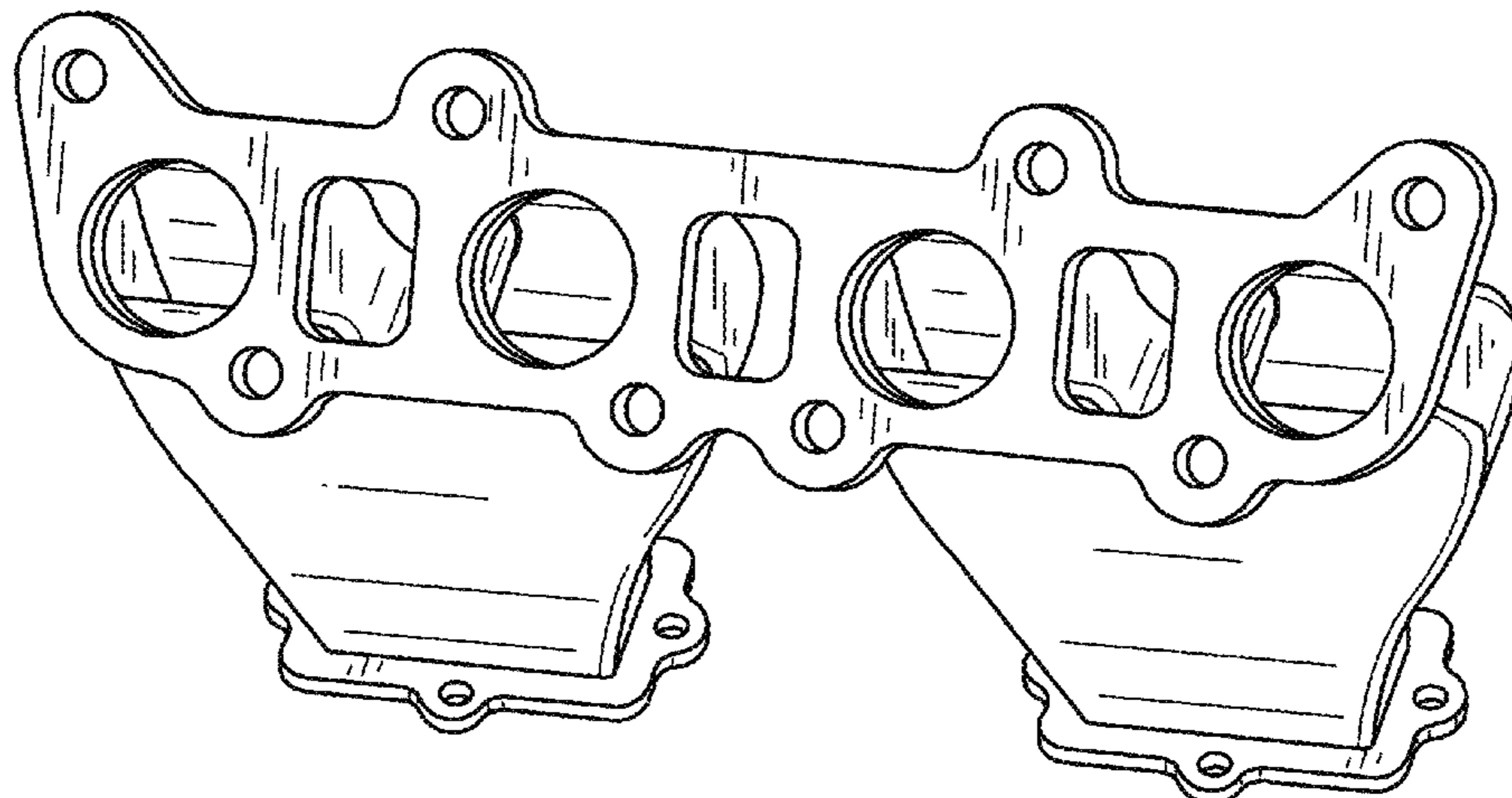

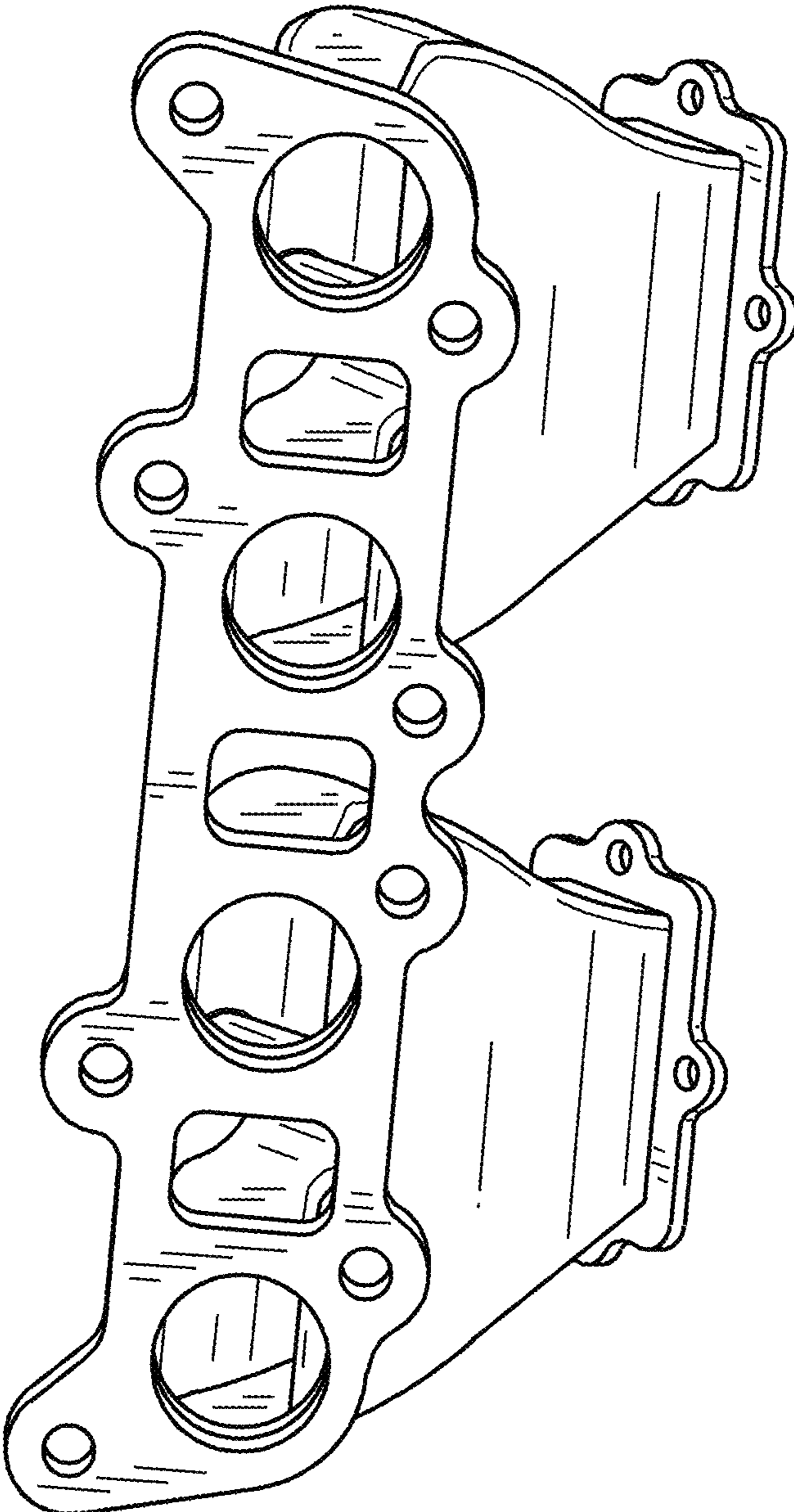

FIG. 1

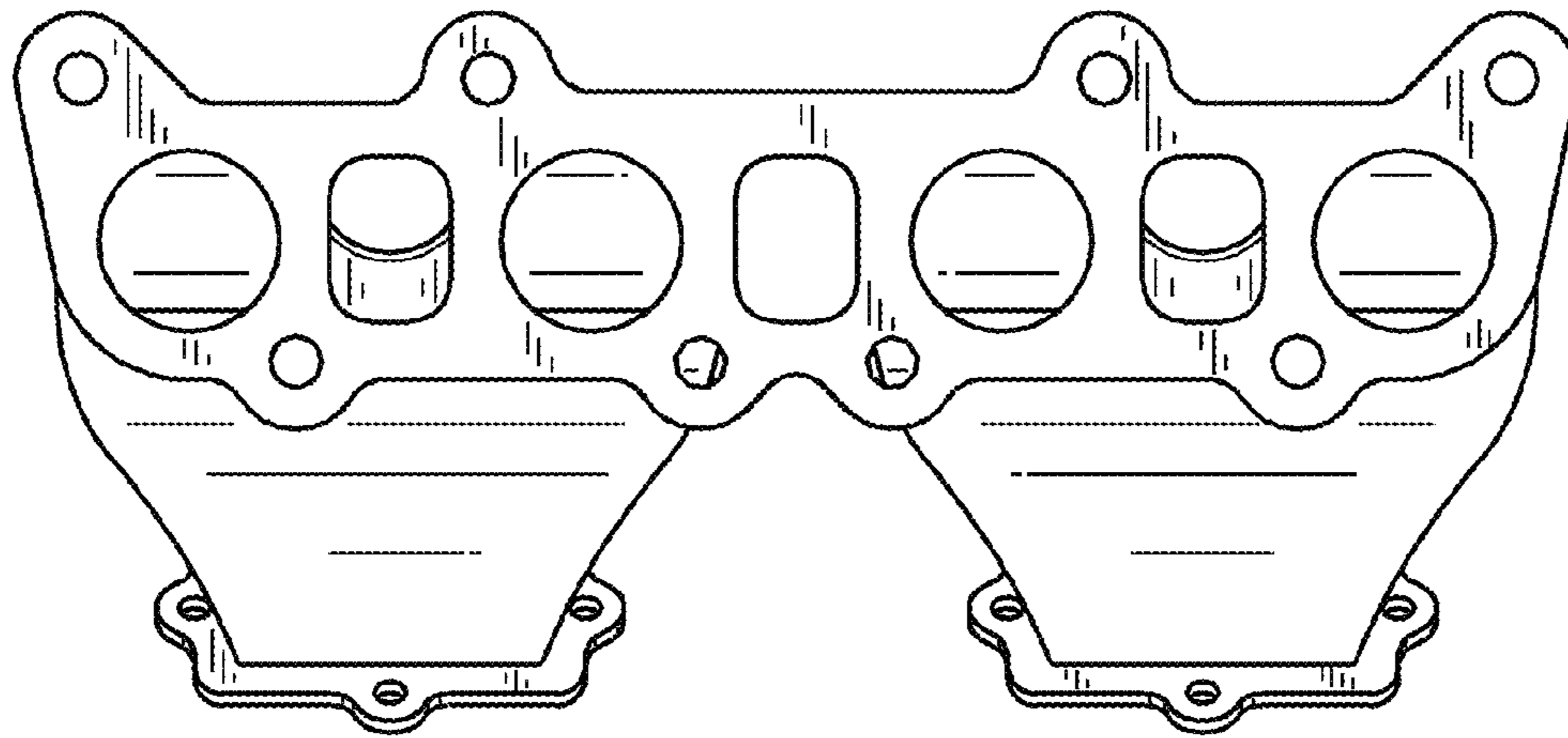

FIG. 2

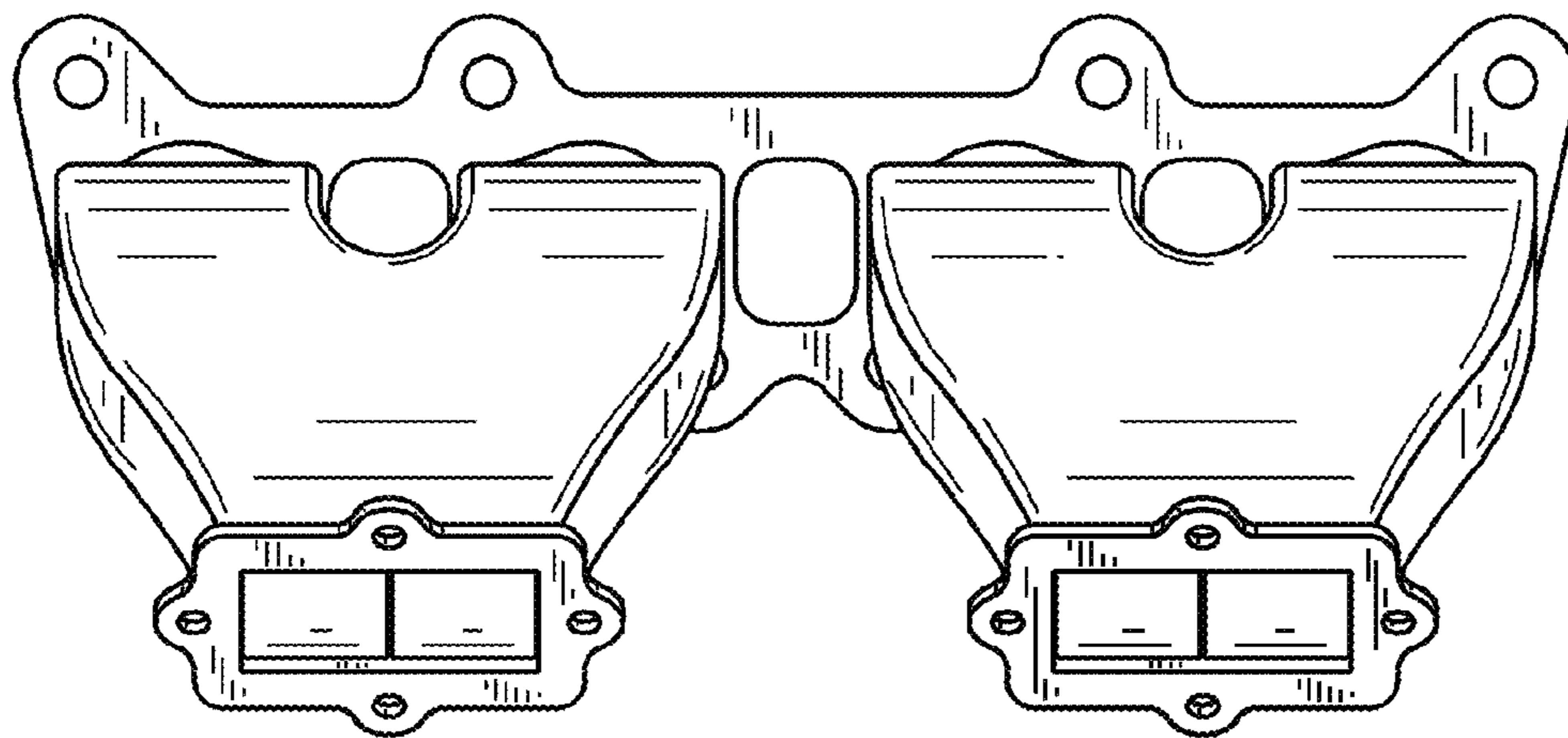

FIG. 3

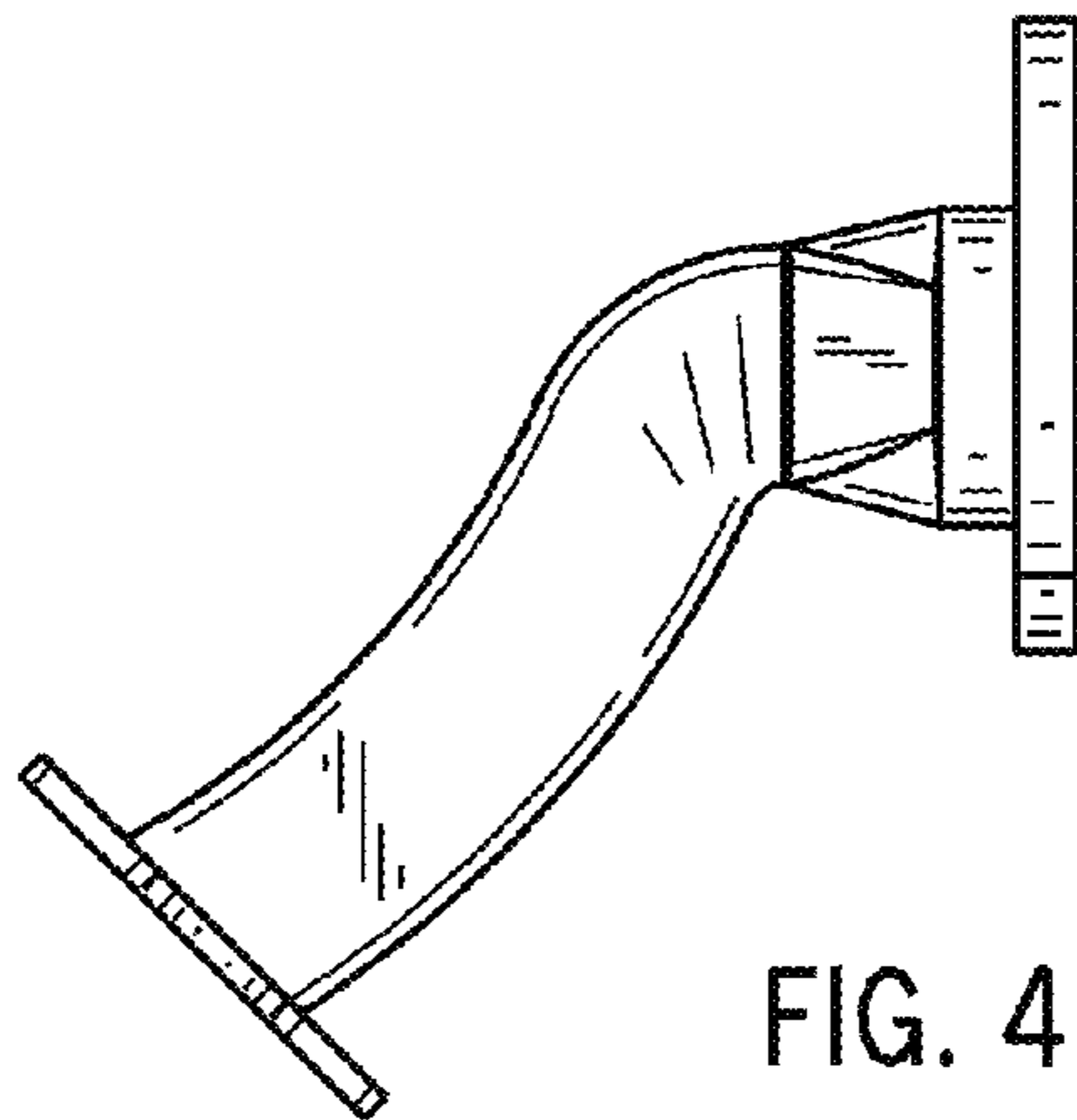

FIG. 4

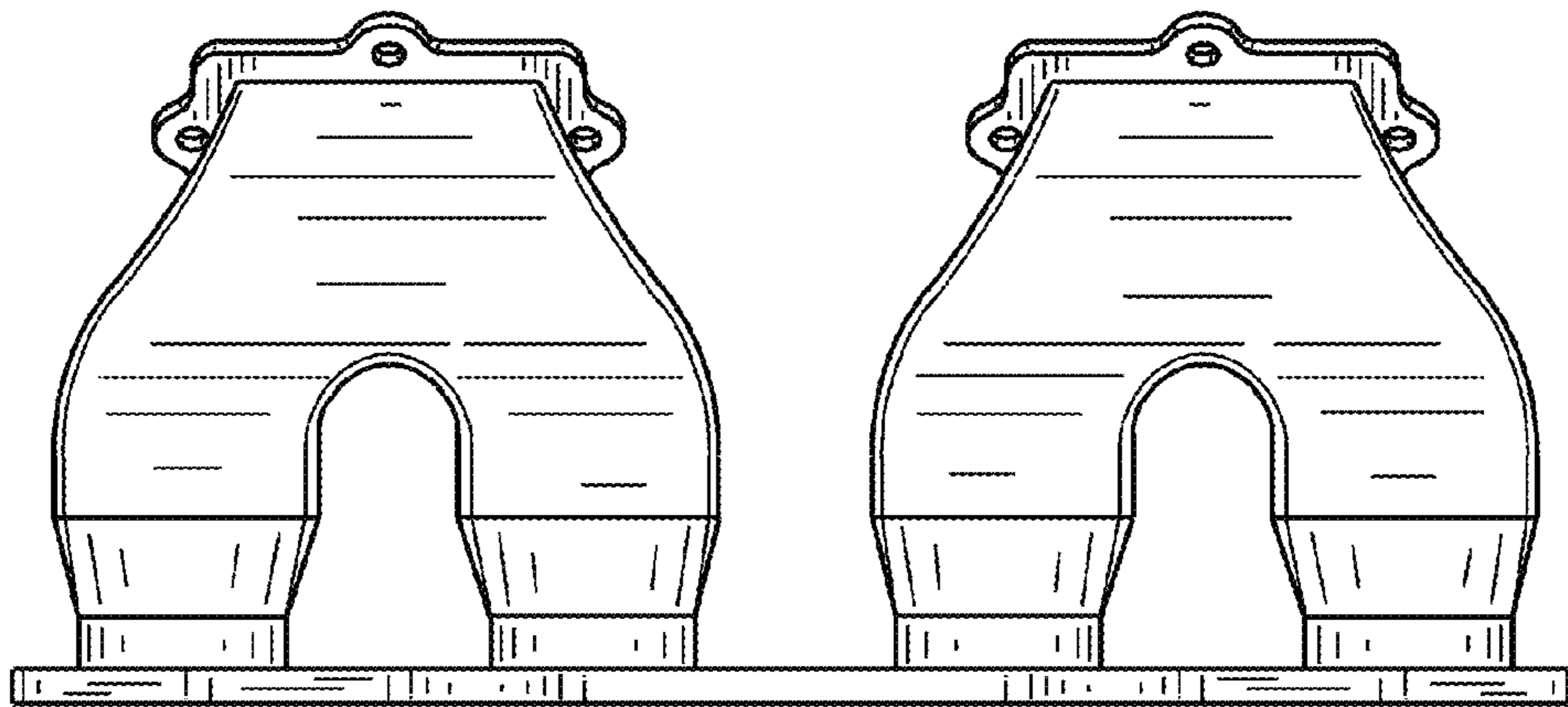

FIG. 5

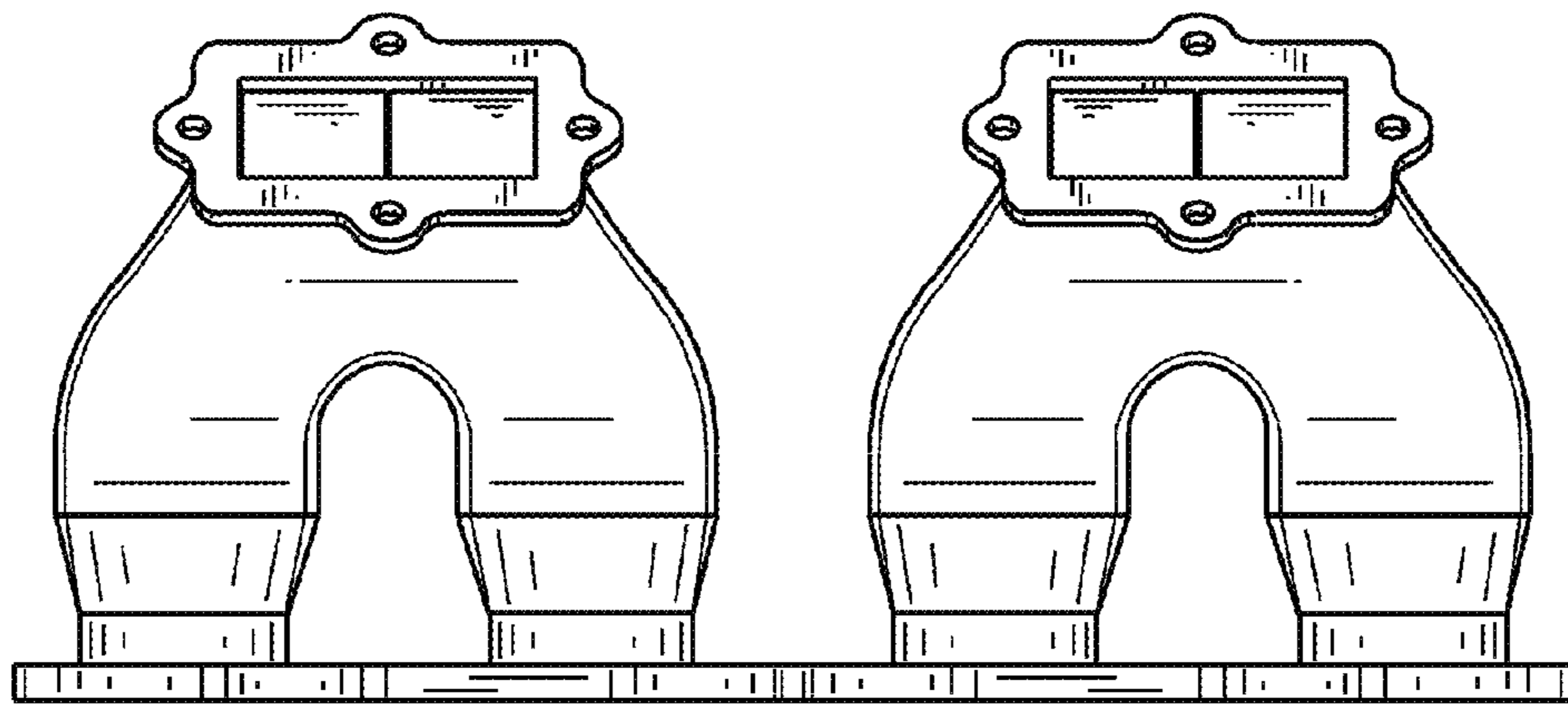

FIG. 6