



US00D765003S

(12) **United States Design Patent**
Toth

(10) **Patent No.:** **US D765,003 S**

(45) **Date of Patent:** **** Aug. 30, 2016**

(54) **WHEEL OR WHEEL COVER**

(71) Applicant: **Daimler AG**, Stuttgart (DE)

(72) Inventor: **Benedek Toth**, Laguna Hills, CA (US)

(73) Assignee: **Daimler AG**, Stuttgart (DE)

(**) Term: **14 Years**

(21) Appl. No.: **29/520,187**

(22) Filed: **Mar. 12, 2015**

(30) **Foreign Application Priority Data**

Sep. 15, 2014 (EM) 002538256-0001

(51) **LOC (10) Cl.** **12-16**

(52) **U.S. Cl.**
USPC **D12/211**

(58) **Field of Classification Search**
USPC D12/204–213
CPC B60B 7/00; B60B 7/02; B60B 7/04;
B60B 7/01; B60B 7/06; B60B 3/02; B60B
3/04; B60B 3/06; B60B 3/10; B60B 1/00;
B60B 1/08; B60B 1/10; B60B 1/12
See application file for complete search history.

(56) **References Cited**

U.S. PATENT DOCUMENTS

D437,821 S * 2/2001 Frohlich D12/211
D476,938 S * 7/2003 Hatori D12/209
D526,262 S * 8/2006 Guevara D12/209
D530,253 S * 10/2006 Coutts D12/209
D530,657 S * 10/2006 Pfeiffer D12/211
D531,565 S * 11/2006 Pfeiffer D12/211

D538,216 S * 3/2007 Sycha D12/209
D587,178 S * 2/2009 Pfeiffer D12/209
D587,180 S * 2/2009 Pfeiffer D12/209
D595,203 S * 6/2009 Rak D12/211
D601,074 S * 9/2009 Buschmann D12/209
D628,527 S * 12/2010 Faghihzadeh D12/211
D645,391 S * 9/2011 Weil D12/209
D671,875 S * 12/2012 Camacho D12/209
D719,076 S * 12/2014 McLeod D12/211

FOREIGN PATENT DOCUMENTS

EM 002417170-0003 3/2014
EM 002468249-0001 5/2014
EM 002403139-0001 7/2014
EM 002470922-0001 10/2014

* cited by examiner

Primary Examiner — Stacia Cadmus

(74) *Attorney, Agent, or Firm* — Crowell & Moring LLP

(57) **CLAIM**

The ornamental design for a wheel or wheel cover, as shown and described.

DESCRIPTION

FIG. 1 is a front view of a wheel or wheel cover according to the design; and,

FIG. 2 is a perspective view thereof.

The broken line showing of the rear of the wheel and the bolt holes and the center hole in the central hub area is included for the purpose of illustrating environment and forms no part of the claimed design.

1 Claim, 1 Drawing Sheet

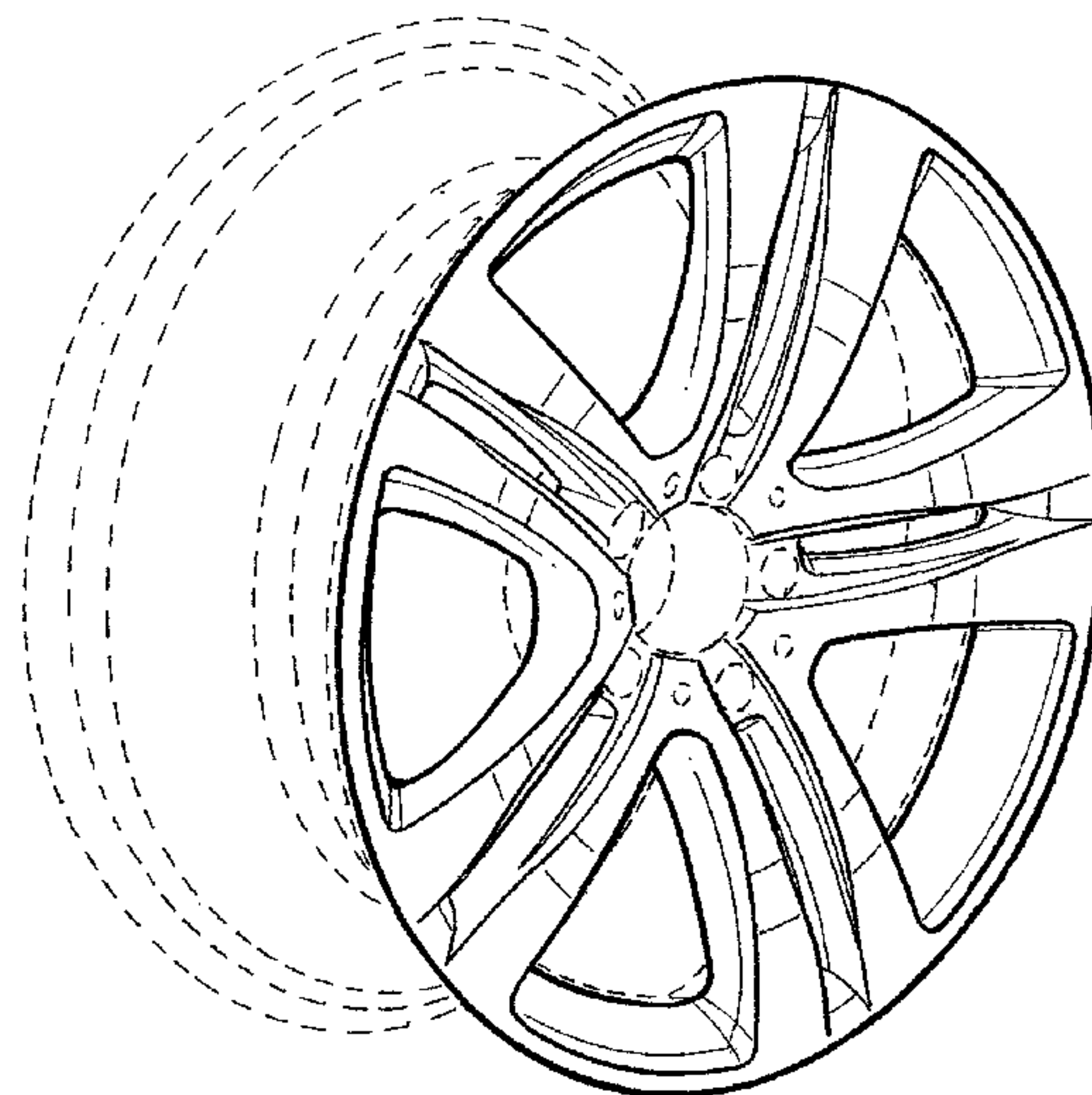
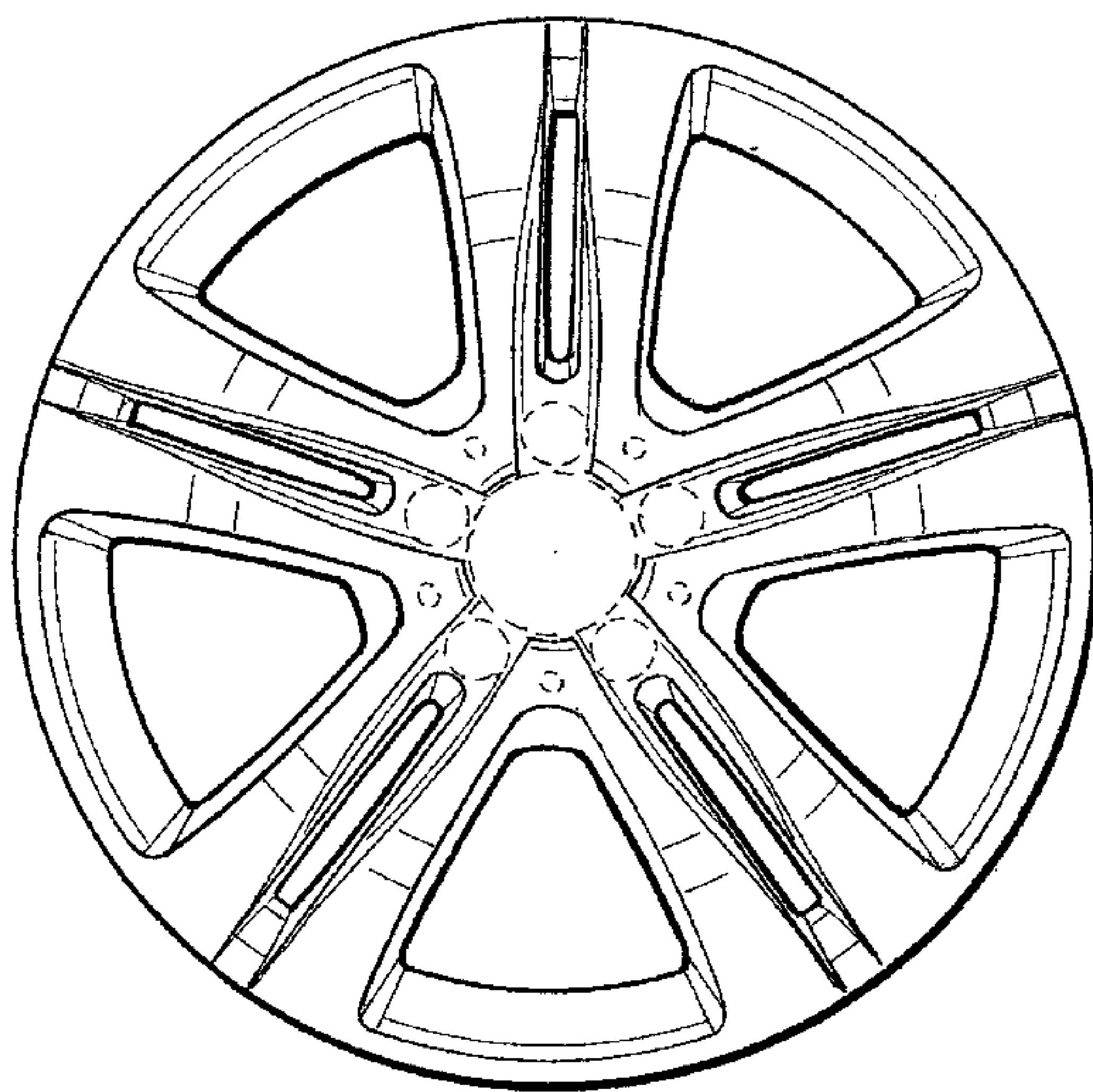

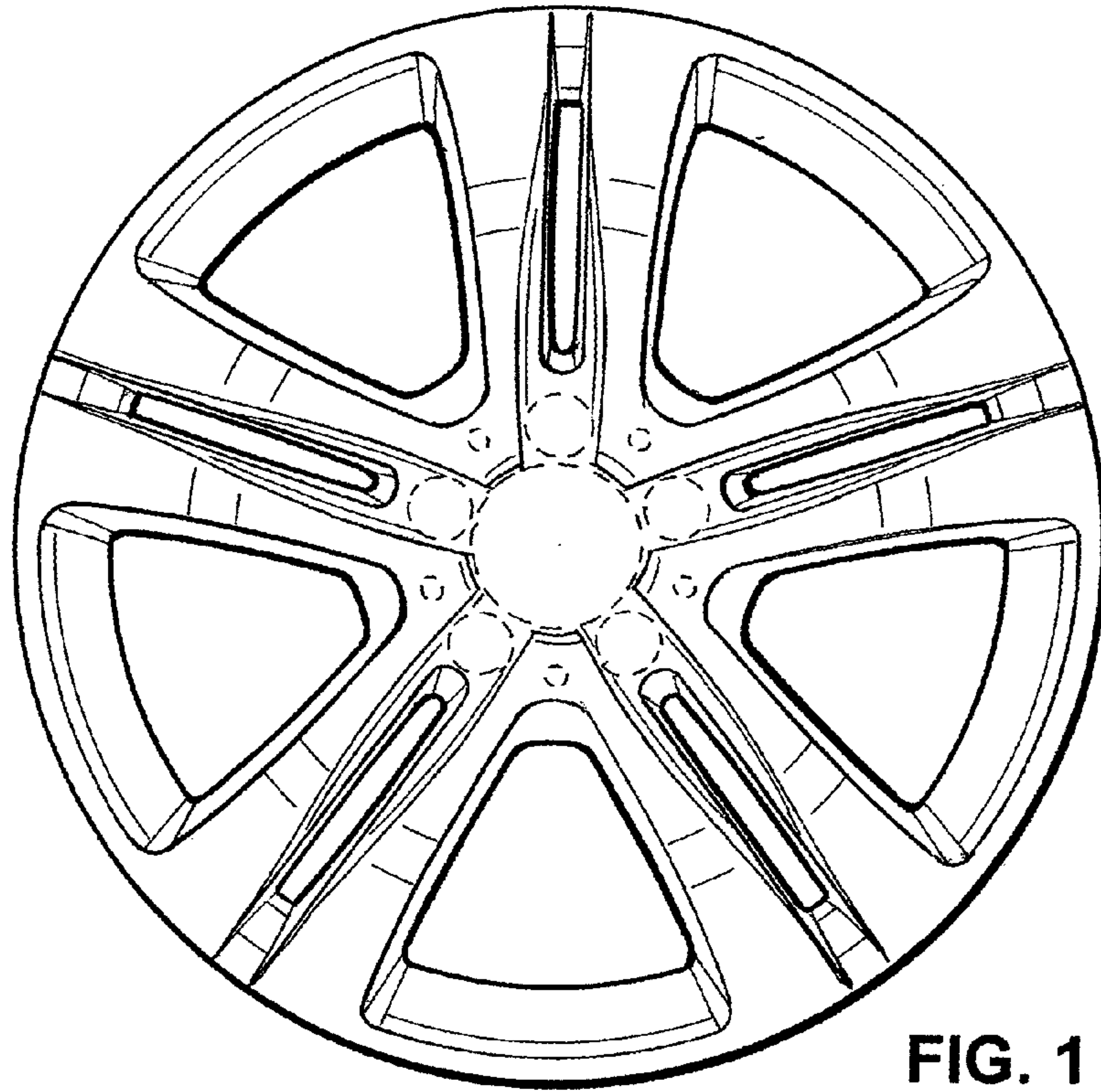

FIG. 1

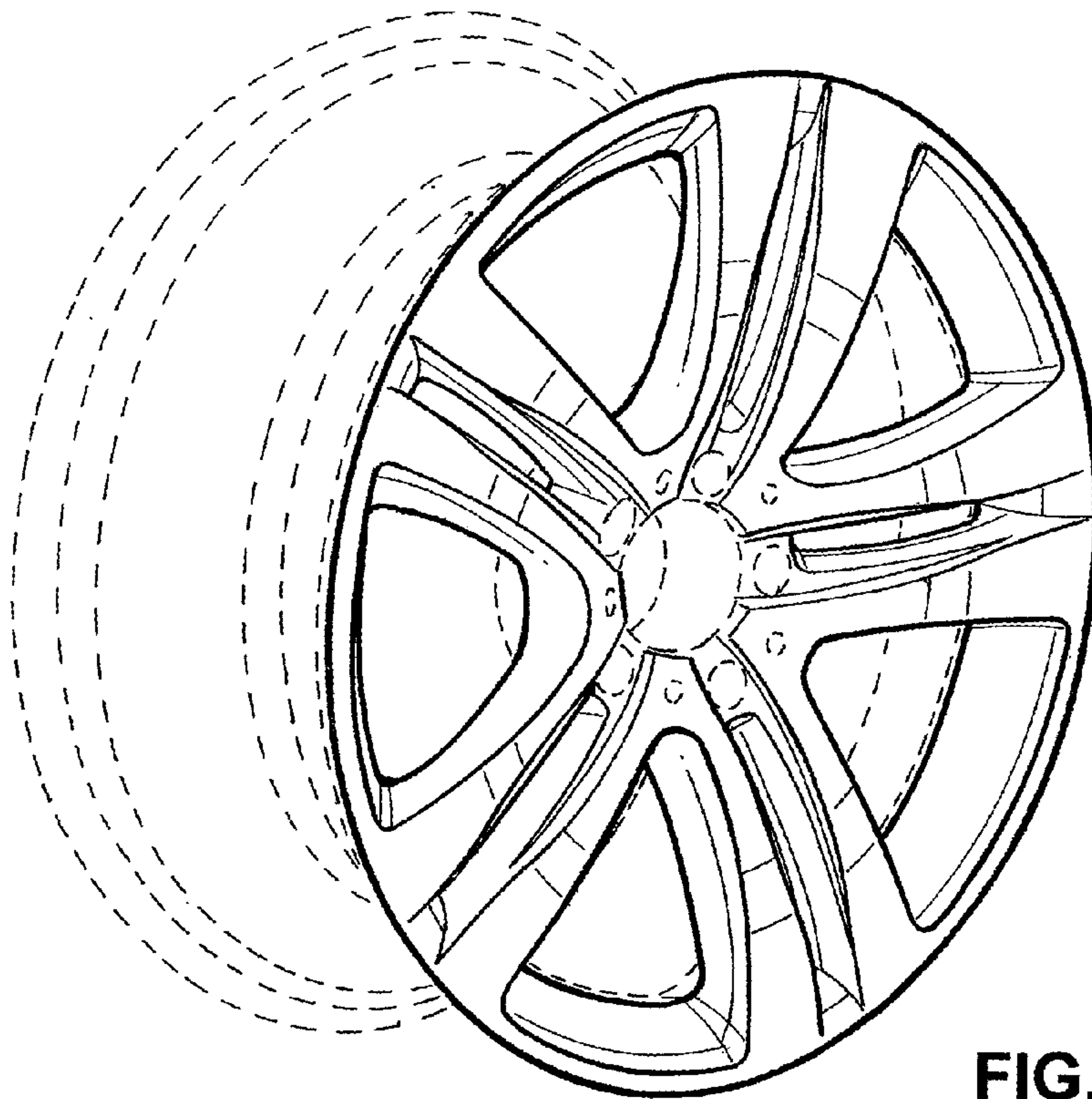

FIG. 2