

US00D764379S

(12) **United States Design Patent**  
**Conrad**

(10) **Patent No.:** **US D764,379 S**  
(45) **Date of Patent:** **\*\* Aug. 23, 2016**

(54) **MIDDLE RAIL FOR A WATERCRAFT**

(71) Applicant: **Premier Marine, Inc.**, Wyoming, MN (US)

(72) Inventor: **Kristie Conrad**, Cambridge, MN (US)

(73) Assignee: **Premier Marine, Inc.**, Wyoming, MN (US)

(\*\*) Term: **15 Years**

(21) Appl. No.: **29/526,855**

(22) Filed: **May 13, 2015**

(51) **LOC (10) Cl.** ..... **12-06**

(52) **U.S. Cl.**  
USPC ..... **D12/317; D25/38.1**

(58) **Field of Classification Search**  
USPC ..... D12/300–318; D25/38.1, 41.1, 124;  
114/61.1, 61.14, 61.2, 61.22, 61.24,  
114/343, 352, 355, 356, 357, 361, 364  
CPC ..... B63B 1/12; B63B 1/121; B63B 1/125;  
B63B 17/02; B63B 17/026; B63B 17/04  
See application file for complete search history.

(56) **References Cited**

**U.S. PATENT DOCUMENTS**

D258,279 S 2/1981 Moore  
D335,353 S 5/1993 Baker  
5,706,753 A \* 1/1998 Menne ..... B63B 17/02  
114/361  
5,706,754 A \* 1/1998 Menne, Jr. .... B63B 17/04  
114/364

D415,075 S 10/1999 Lan  
6,234,098 B1 \* 5/2001 Biedenweg ..... B63B 3/48  
114/61.1  
D455,634 S \* 4/2002 Hummel ..... D25/124  
D499,494 S 12/2004 Tjakra et al.  
D509,906 S 9/2005 Enersen  
D536,098 S \* 1/2007 Walker ..... D25/38.1  
D560,823 S 1/2008 Holland  
D610,715 S \* 2/2010 Koehn ..... D25/124  
D661,813 S \* 6/2012 Walker ..... D25/38.1  
D732,205 S \* 6/2015 Campbell ..... D25/124  
2007/0022938 A1 \* 2/2007 Fishburn ..... B63B 17/04  
114/364

\* cited by examiner

*Primary Examiner* — Cynthia M Chin

(74) *Attorney, Agent, or Firm* — Winthrop & Weinstine, P.A.

(57) **CLAIM**

The ornamental design for a middle rail for a watercraft, as shown and described.

**DESCRIPTION**

FIG. 1 is a perspective view of a middle rail for a watercraft; FIG. 2 is a cross-sectional/end view of FIG. 1; FIG. 3 is a front view of FIG. 1; FIG. 4 is a rear view of FIG. 1; FIG. 5 is a top view of FIG. 1; FIG. 6 is a cross-sectional/end view of FIG. 1 as viewed from opposite the view of FIG. 2; and, FIG. 7 is a bottom view of FIG. 1. The broken away symbols in the drawings indicate the appearance of any portion of the article between the break lines forms no part of the claimed design.

**1 Claim, 3 Drawing Sheets**

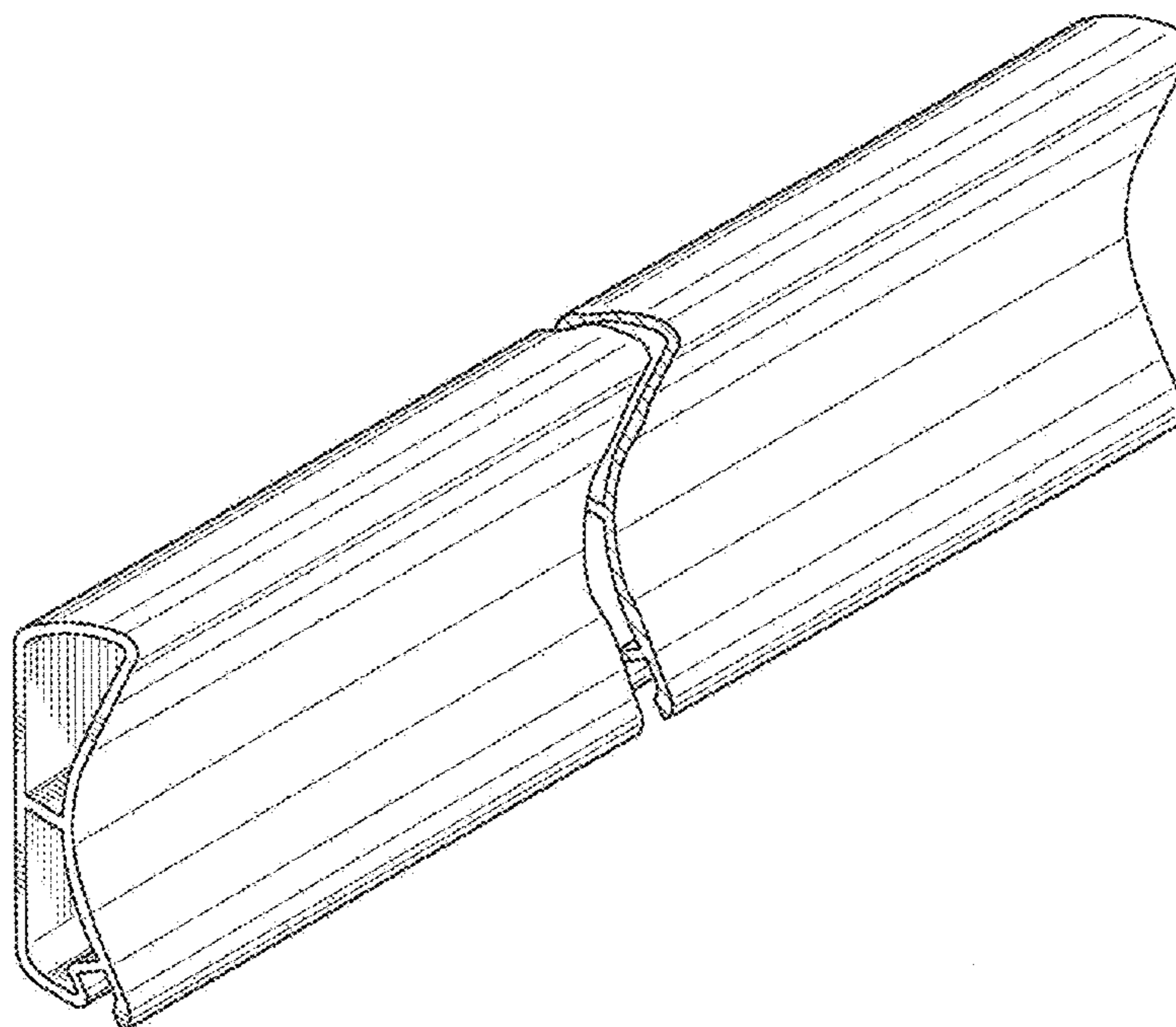

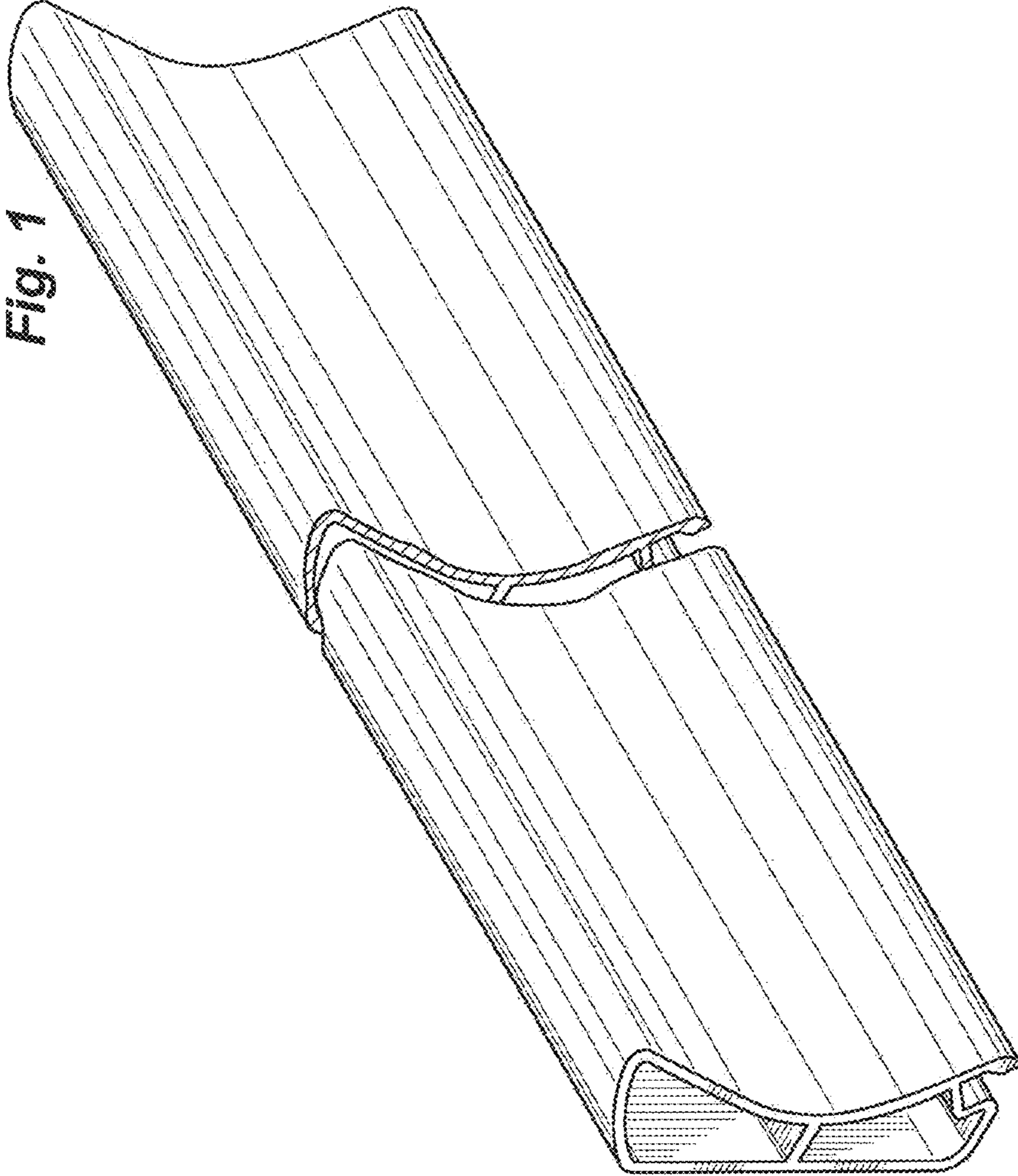

Fig. 1

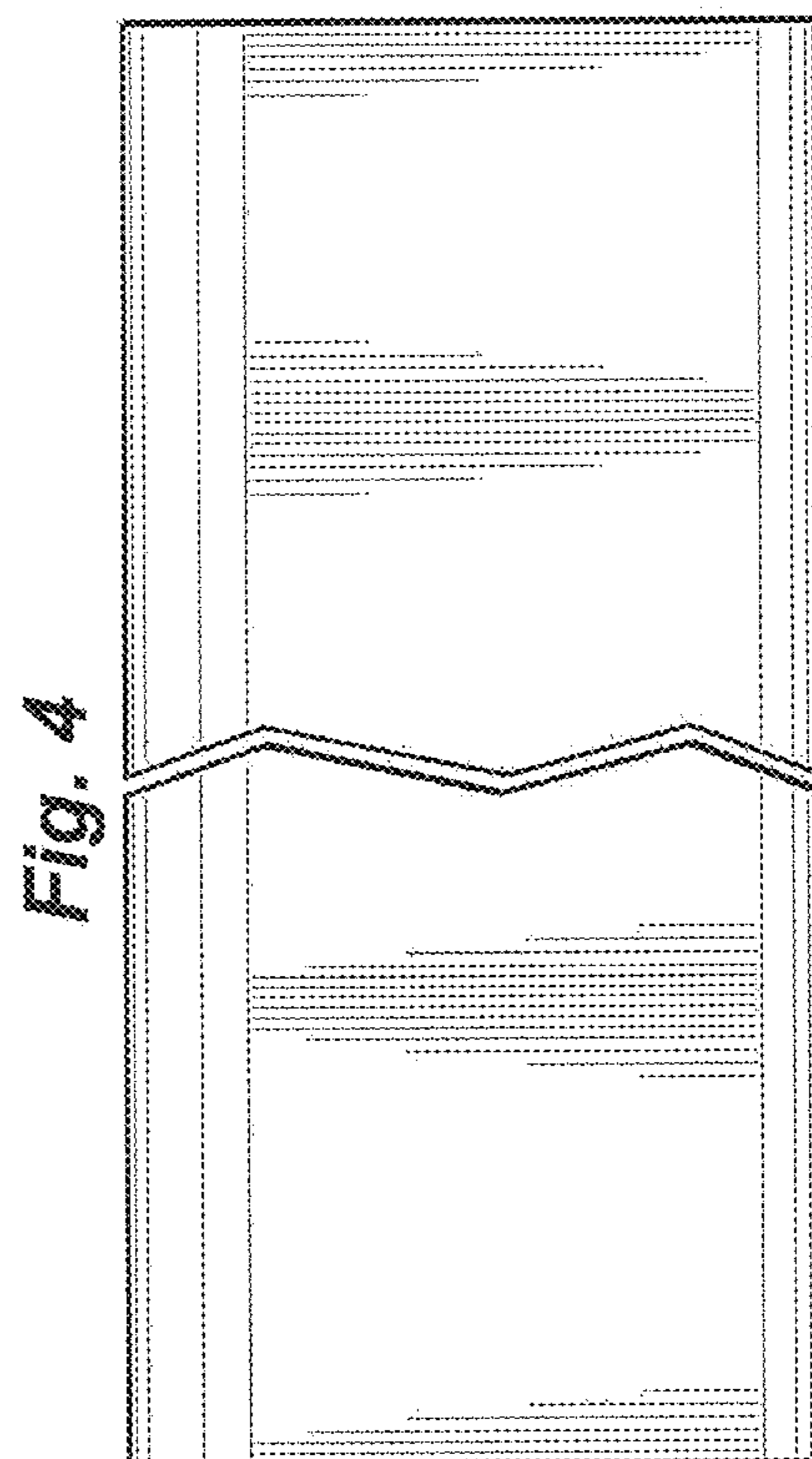
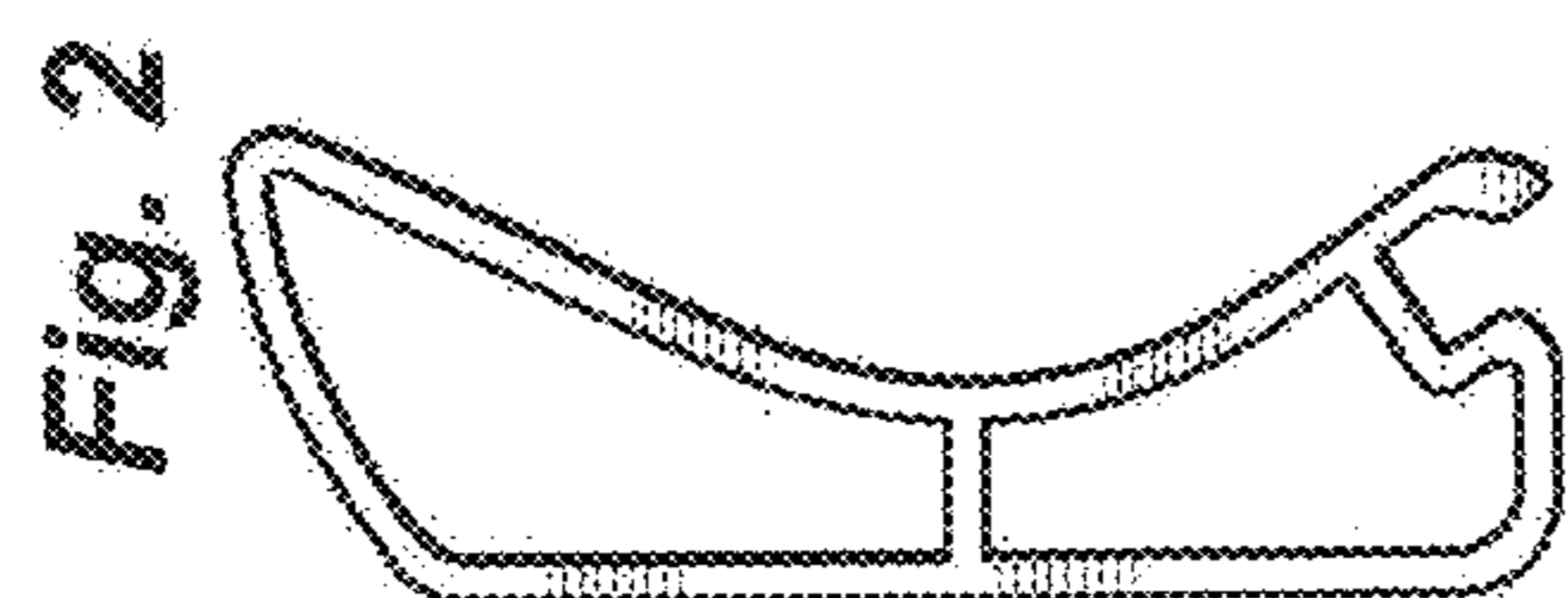
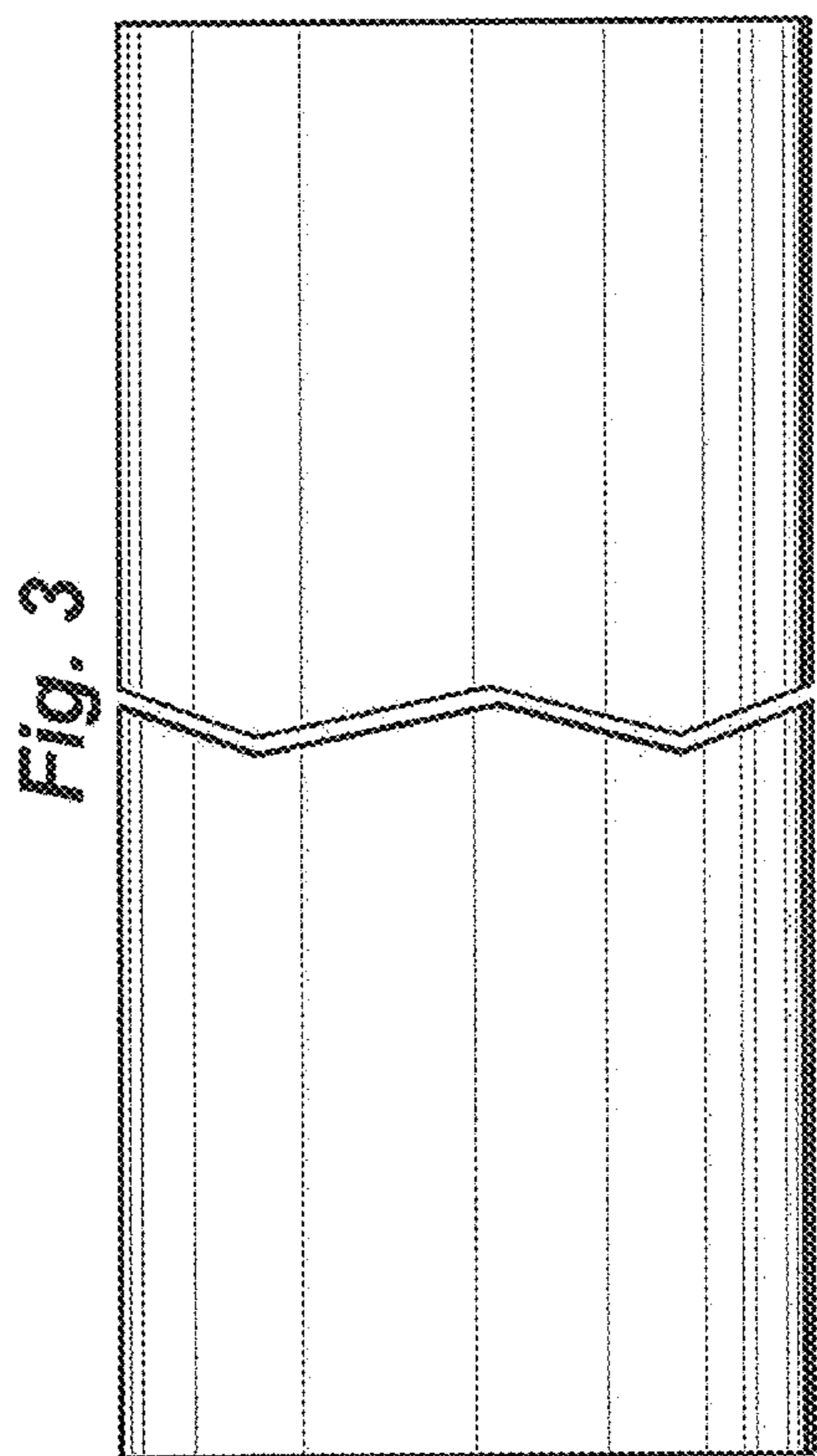



Fig. 6

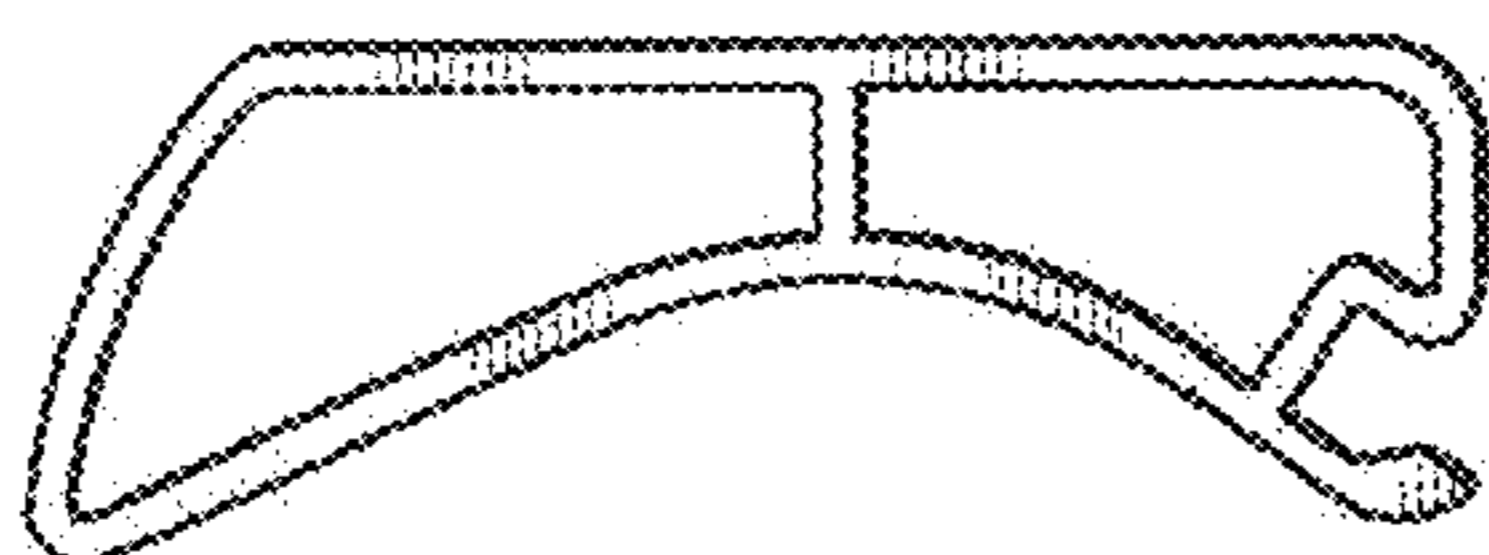

Fig. 5

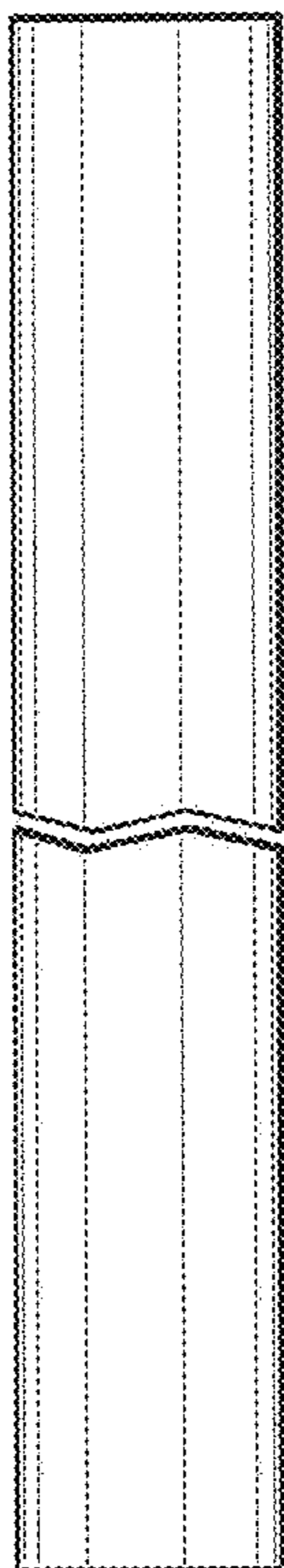

Fig. 7

