



US00D764350S

(12) **United States Design Patent** (10) **Patent No.:** **US D764,350 S**
Okuyama et al. (45) **Date of Patent:** **** Aug. 23, 2016**

(54) **UTILITY VEHICLE**

(71) Applicant: **YANMAR CO., LTD.**, Osaka-shi,
Osaka (JP)

(72) Inventors: **Kiyoyuki Okuyama**, Yamagata (JP);
Masaaki Yamashita, Osaka (JP);
Tsuyoshi Kawakami, Osaka (JP);
Daisuke Hirata, Osaka (JP)

(73) Assignee: **Yanmar Co., Ltd.**, Osaka (JP)

(**) Term: **14 Years**

(21) Appl. No.: **29/526,397**

(22) Filed: **May 8, 2015**

(30) **Foreign Application Priority Data**

Nov. 11, 2014 (JP) D2014-025169

(51) **LOC (10) Cl.** **12-13**

(52) **U.S. Cl.**
USPC **D12/14**

(58) **Field of Classification Search**
USPC D12/1, 2, 13, 12, 15, 14, 16, 86, 87, 3,
D12/4, 5, 85, 107, 110, 173; D21/14, 424,
D21/433, 803; D15/30; 296/1.01, 24.33,
296/181.1, 181.2, 181.4, 187.01, 187.09,
296/187.11, 187.12, 190.08, 192, 193.05,
296/193.11, 181.5; 280/183-185, DIG. 5, 1,
280/16, 82, 88, 90, 14, 756; 180/233, 908,
180/89.1, 89.11, 6.5

CPC B62D 35/00; B62D 39/00; B62D 47/00;
B62D 47/003; B62D 63/02; B62D 33/0617;
B62D 33/00; A01B 59/02; B60L 2200/22;
B60Y 2200/86; B60Y 2200/91; B60R 21/13

See application file for complete search history.

(56) **References Cited**

U.S. PATENT DOCUMENTS

D604,201	S	*	11/2009	Kawaguchi	D12/14
D642,493	S	*	8/2011	Goibert	D12/87
D675,960	S	*	2/2013	Hashimoto	D12/87
D682,738	S	*	5/2013	Li	D12/14
D699,627	S	*	2/2014	Tang	D12/14
D700,869	S	*	3/2014	Sato	D12/14
D701,143	S	*	3/2014	Shan	D12/87
8,752,879	B1	*	6/2014	Heit	B60P 3/423 296/39.1
D712,309	S	*	9/2014	Wu	D12/14
D719,061	S	*	12/2014	Tandrup	D12/87
2007/0267241	A1	*	11/2007	Ball	B62D 27/065 180/312
2013/0087402	A1	*	4/2013	Kaku	B60K 13/04 180/309
2015/0061275	A1	*	3/2015	Deckard	B60G 21/055 280/788

FOREIGN PATENT DOCUMENTS

JP D1529964 7/2015

* cited by examiner

Primary Examiner — T. Chase Nelson

Assistant Examiner — Ania Aman

(74) *Attorney, Agent, or Firm* — Sterne, Kessler, Goldstein & Fox P.L.L.C.

(57) **CLAIM**

The ornamental design for a utility vehicle, as shown and described.

DESCRIPTION

FIG. 1 is a front perspective view of a utility vehicle showing our new design;
FIG. 2 is a right side view thereof;
FIG. 3 is a left side view thereof;
FIG. 4 is a top plan view thereof;
FIG. 5 is a bottom plan view thereof;
FIG. 6 is a front view thereof; and,
FIG. 7 is a rear view thereof.

1 Claim, 7 Drawing Sheets

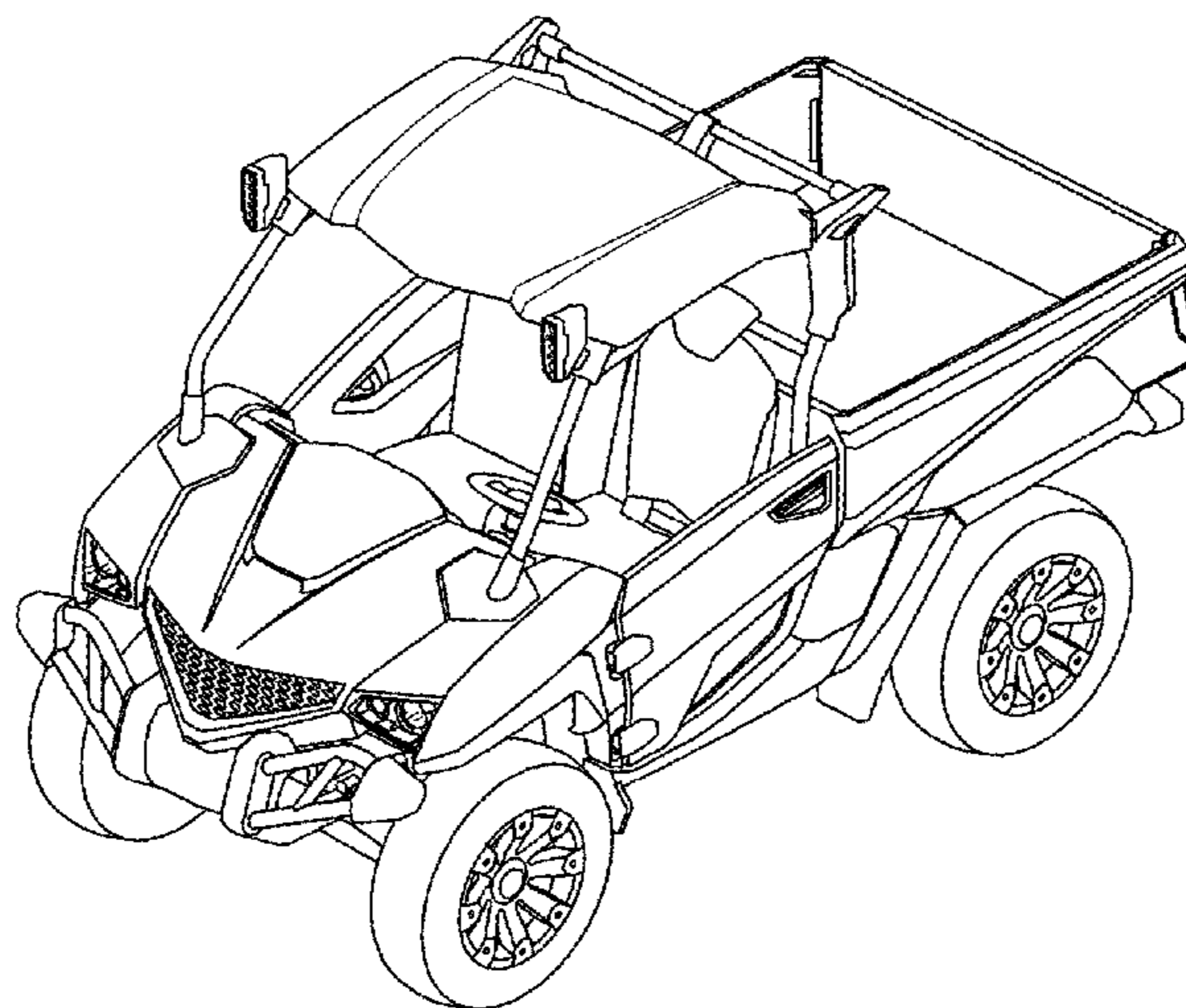

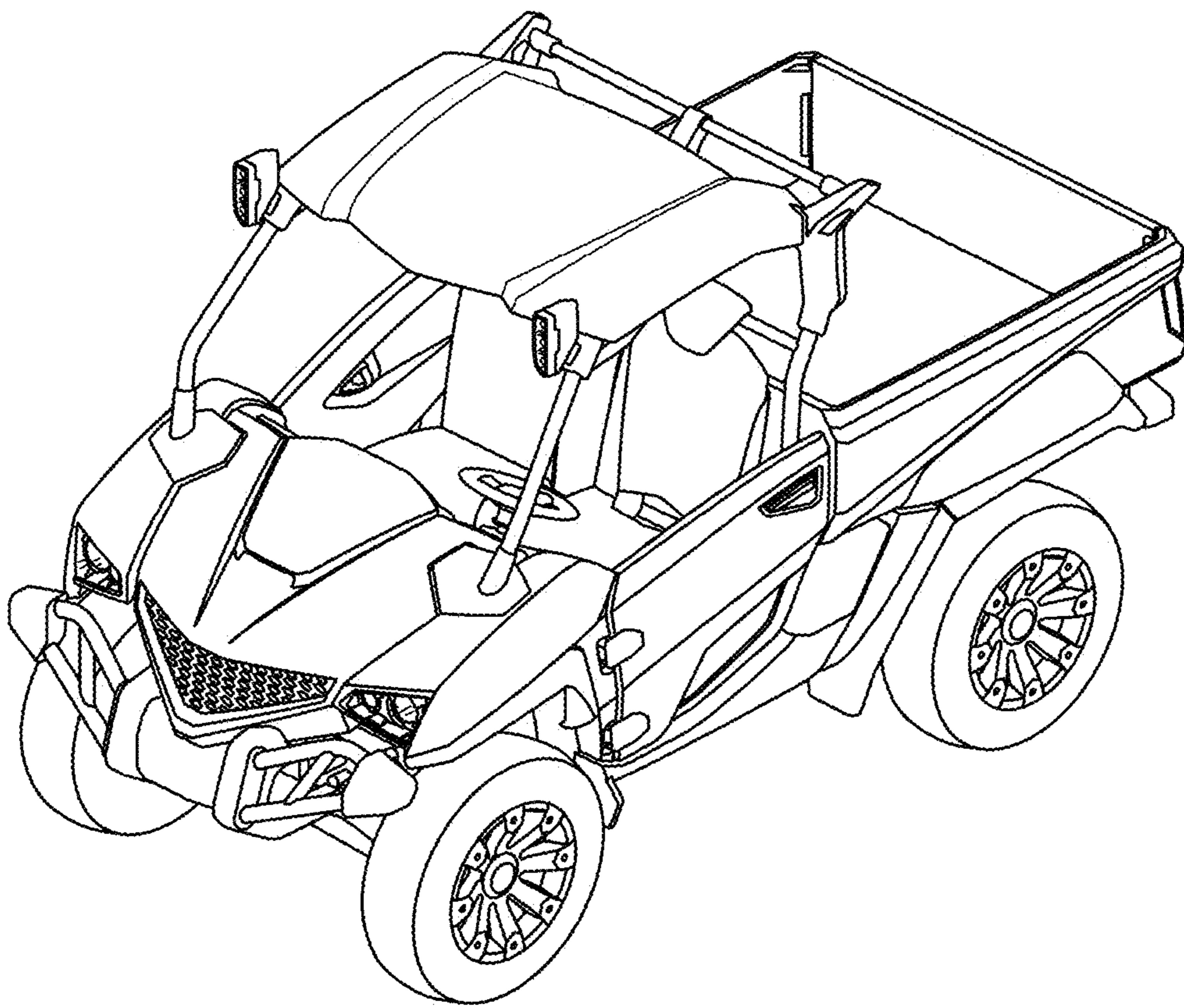

FIG. 1

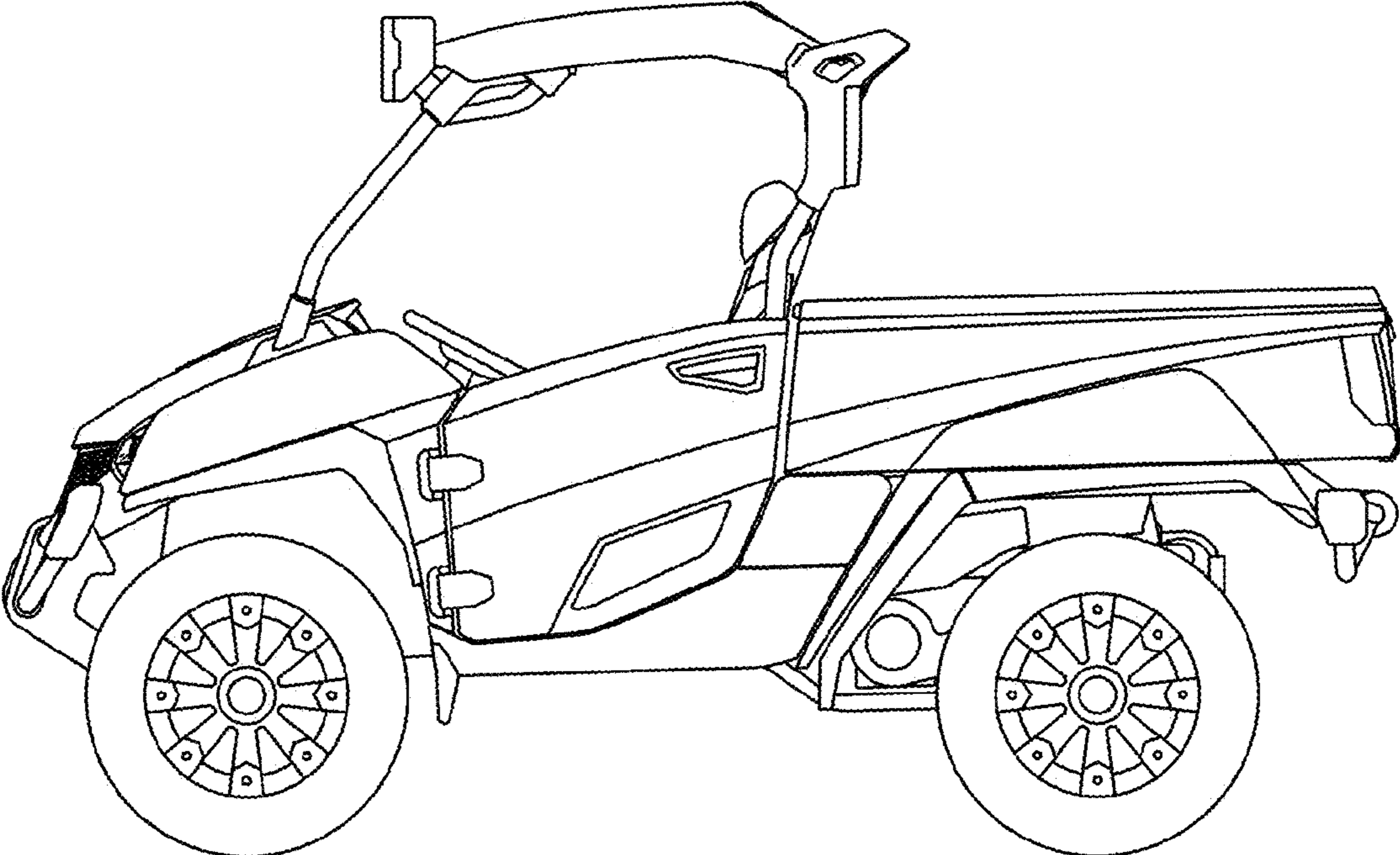

FIG. 2

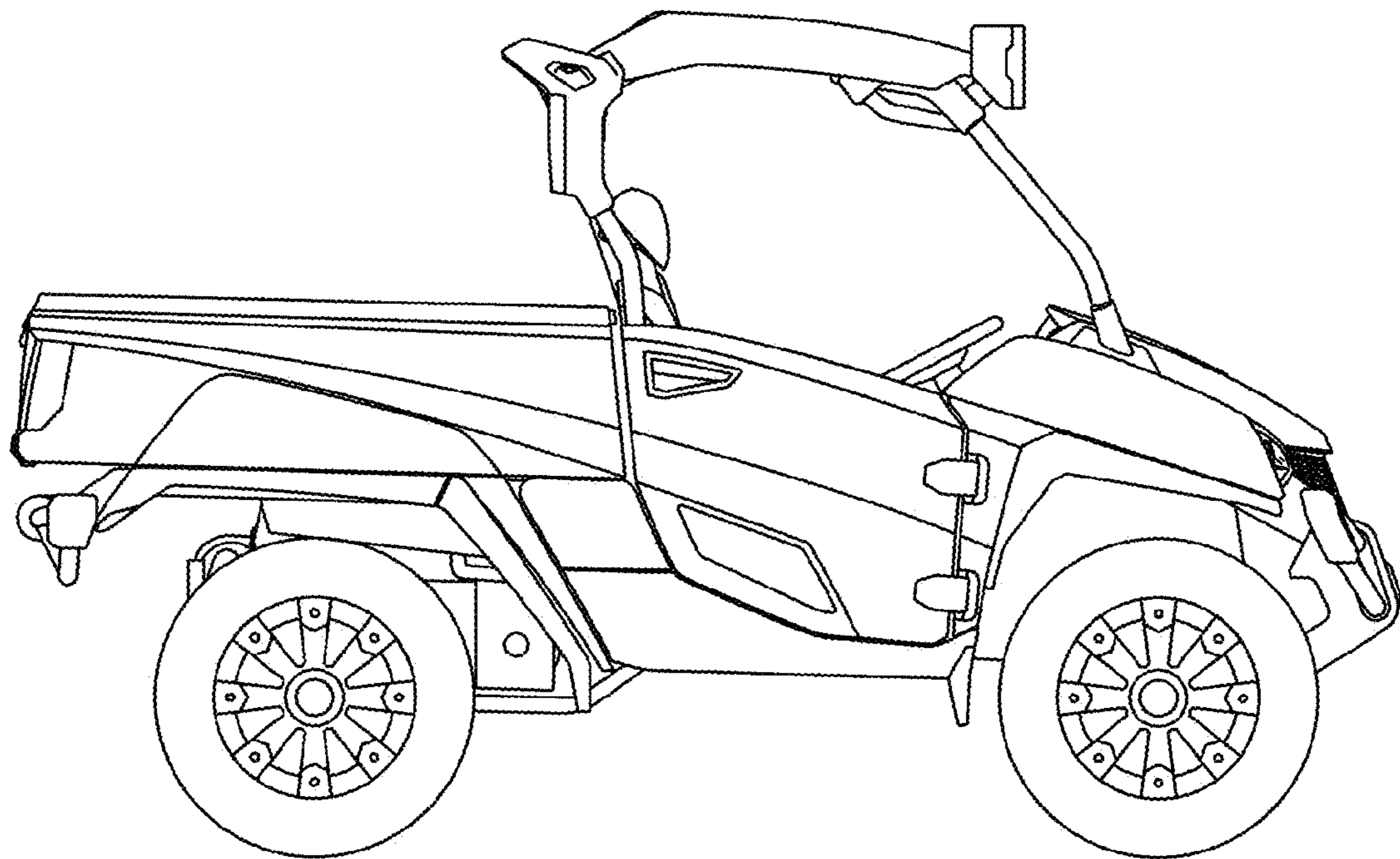

FIG. 3

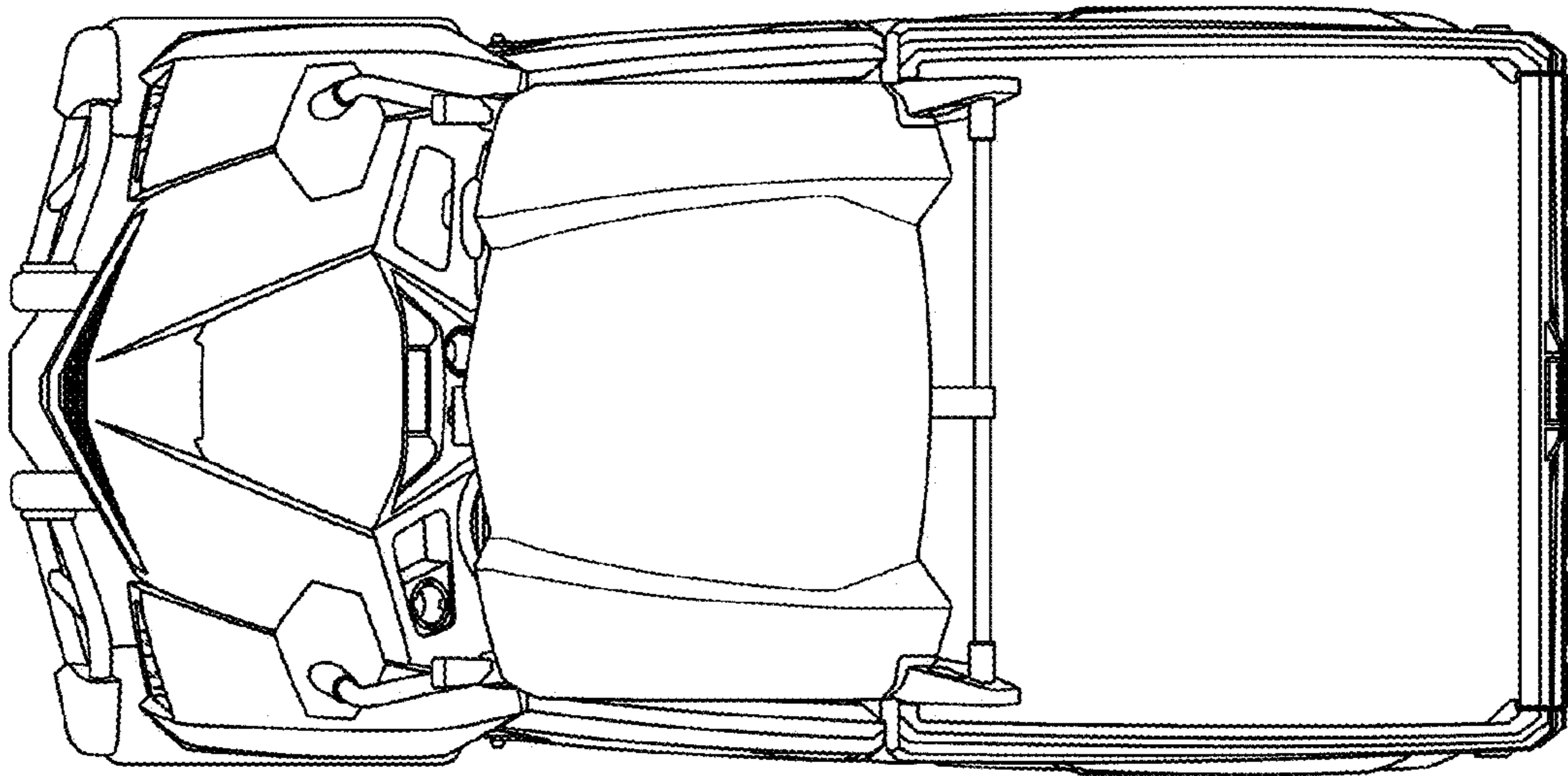

FIG. 4

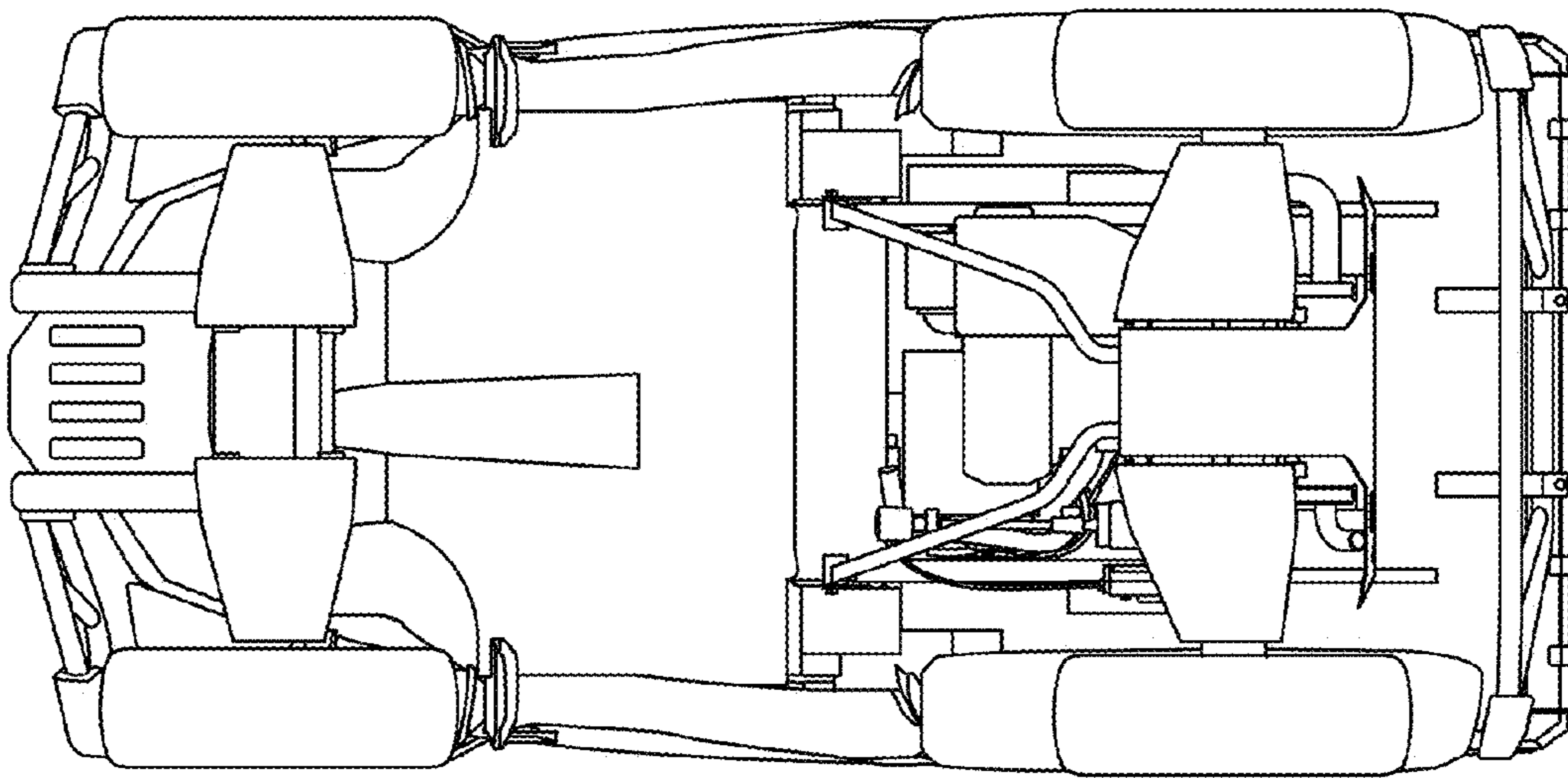

FIG. 5

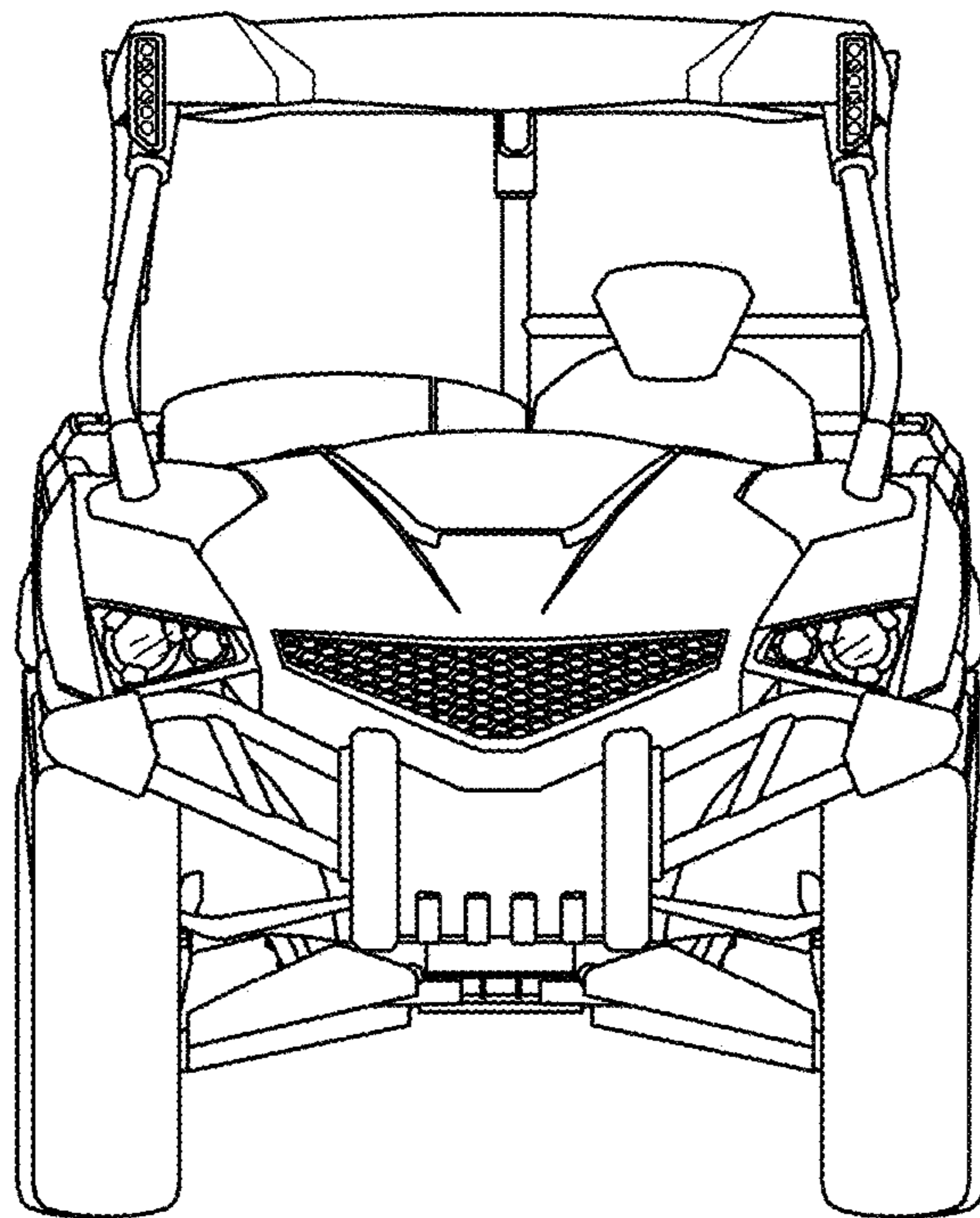

FIG. 6

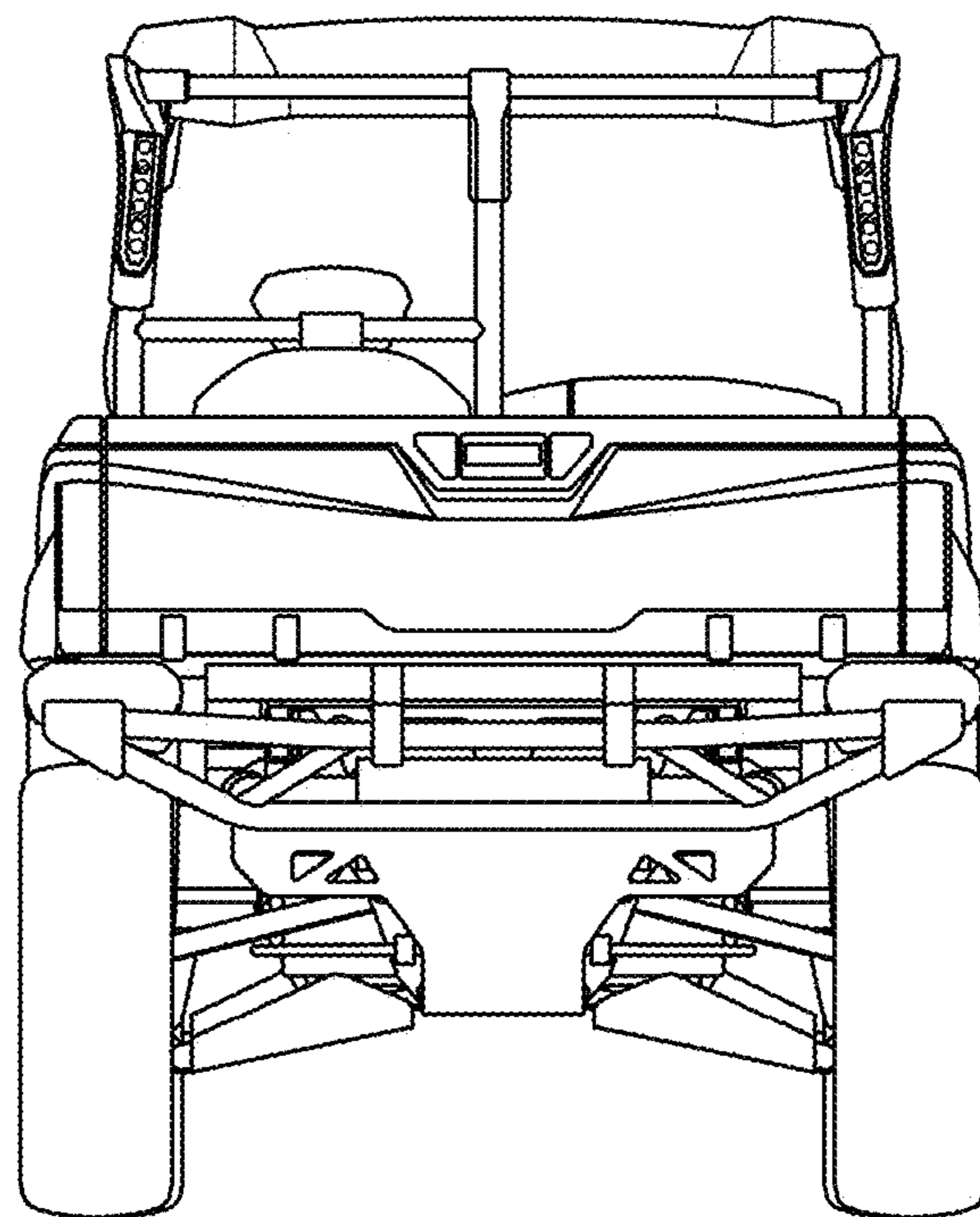

FIG. 7