



US00D764345S

(12) **United States Design Patent**
Burns

(10) **Patent No.:** **US D764,345 S**

(45) **Date of Patent:** **** Aug. 23, 2016**

(54) **RIBBON AWARD**

(71) Applicant: **Jennifer Burns**, Tiffin, OH (US)

(72) Inventor: **Jennifer Burns**, Tiffin, OH (US)

(**) Term: **15 Years**

(21) Appl. No.: **29/531,536**

(22) Filed: **Jun. 26, 2015**

(51) **LOC (10) Cl.** **11-01**

(52) **U.S. Cl.**

USPC **D11/81**; D11/40; D11/66

(58) **Field of Classification Search**

USPC D11/1, 2, 7, 8, 40-45, 47, 48, 66, 69,
D11/70, 74, 75, 77, 78, 79-85, 86, 97, 98,
D11/99

CPC A44C 1/00; A44C 3/00; A44C 3/001;
A44C 3/002; A44C 3/004; A44C 7/00;
A44C 7/002; A44C 7/003; A44C 7/004;
A44C 17/02; A44C 17/0208; A44C 17/0216;
A44C 25/00; A44C 25/001; A44C 25/007;
A44C 25/008

See application file for complete search history.

(56) **References Cited**

U.S. PATENT DOCUMENTS

D378,904 S	*	4/1997	Sciuto	D11/66
D394,822 S	*	6/1998	Swenson	D11/77
D455,978 S	*	4/2002	Brown	D11/98
D464,901 S	*	10/2002	Lomax	D11/30
D473,813 S	*	4/2003	Titus	D11/66
D525,897 S	*	8/2006	Raiman	D11/43

D533,050 S		12/2006	Kelleghan	
D552,009 S	*	10/2007	Jemente D11/79
D591,634 S	*	5/2009	Gorman D11/4
D610,482 S	*	2/2010	Shaw D11/133
D639,700 S		6/2011	Adams et al.	
D646,949 S	*	10/2011	Zaksenberg D8/103
D656,067 S		3/2012	Dunn	
D666,938 S		9/2012	Dunn	
D687,737 S	*	8/2013	Japel D11/96
D726,570 S	*	4/2015	Puterman D11/3

* cited by examiner

Primary Examiner — Garth Rademaker

Assistant Examiner — Melanie Pellegrini

(74) *Attorney, Agent, or Firm* — Fraser Clemens Martin & Miller LLC; Jacob M. Ward

(57) **CLAIM**

The ornamental design for a ribbon award, as shown and described.

DESCRIPTION

FIG. 1 is a top perspective view of a ribbon award showing my new design;

FIG. 2 is a top plan view thereof;

FIG. 3 is a bottom plan view thereof;

FIG. 4 is a left-side elevational view thereof;

FIG. 5 is a right-side elevational view thereof;

FIG. 6 is a rear elevational view thereof; and,

FIG. 7 is a front elevational view thereof.

The broken lines shown in the drawings represent portions of the ribbon award which form no part of the claimed design.

1 Claim, 2 Drawing Sheets

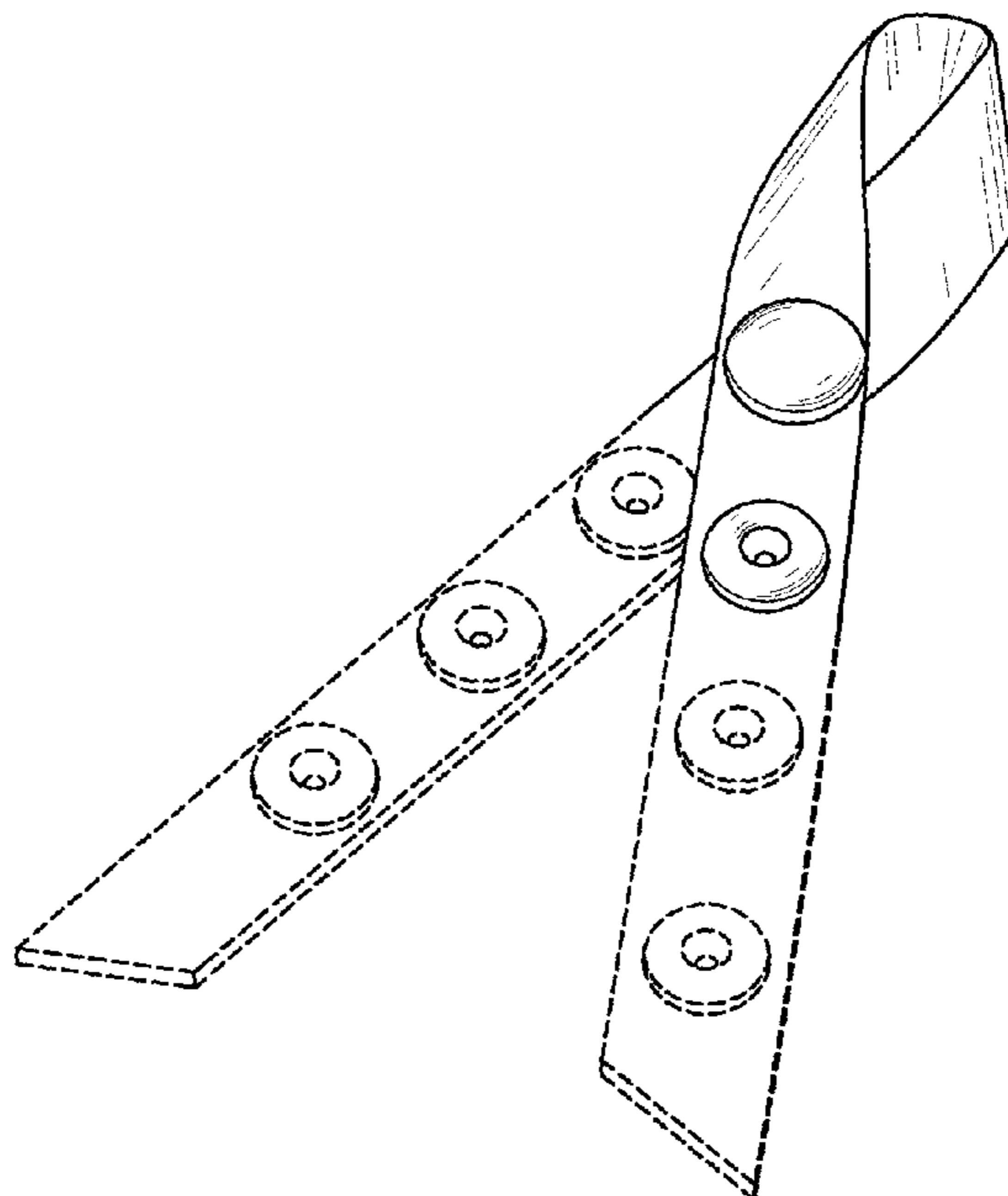

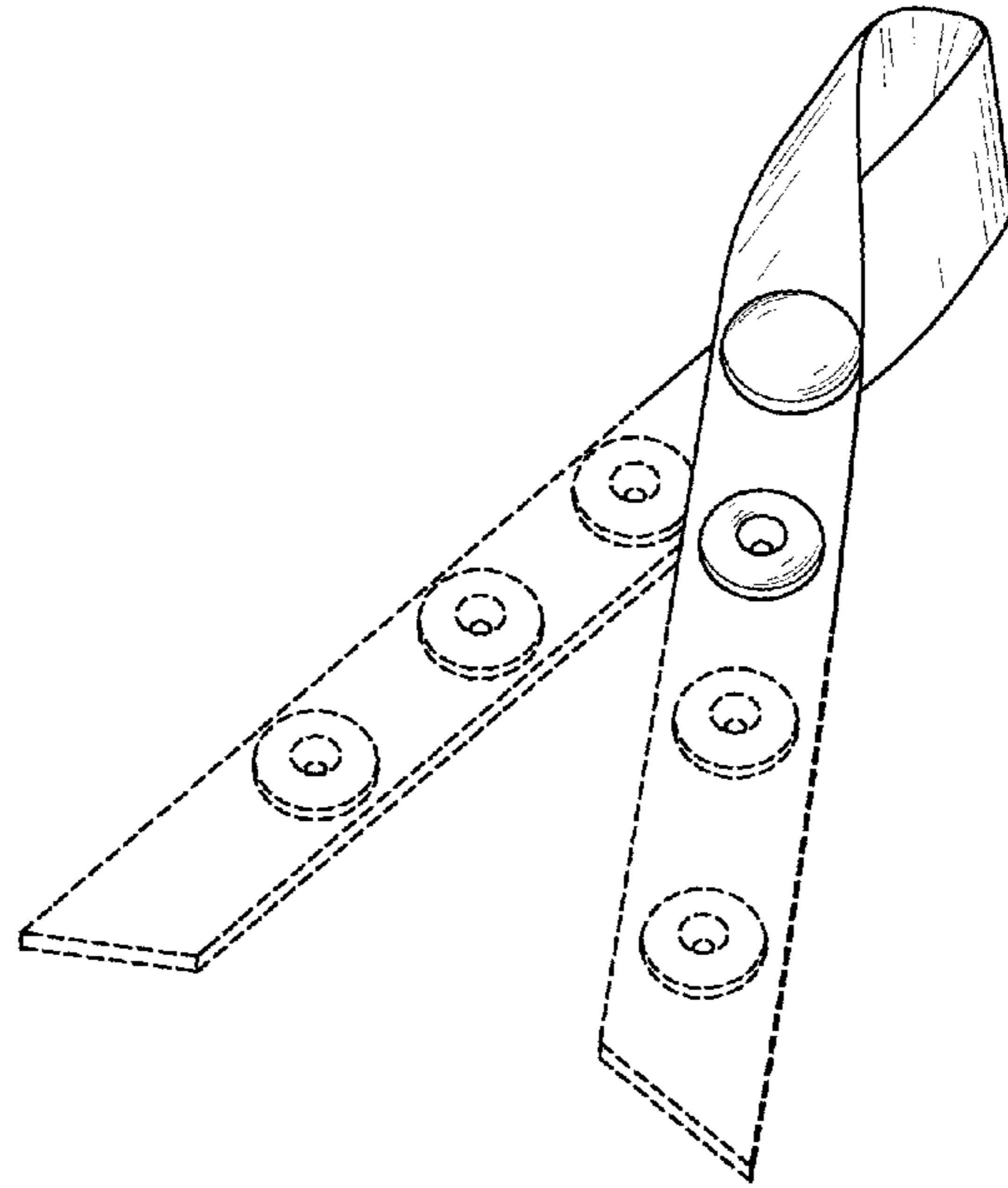

FIG. 1

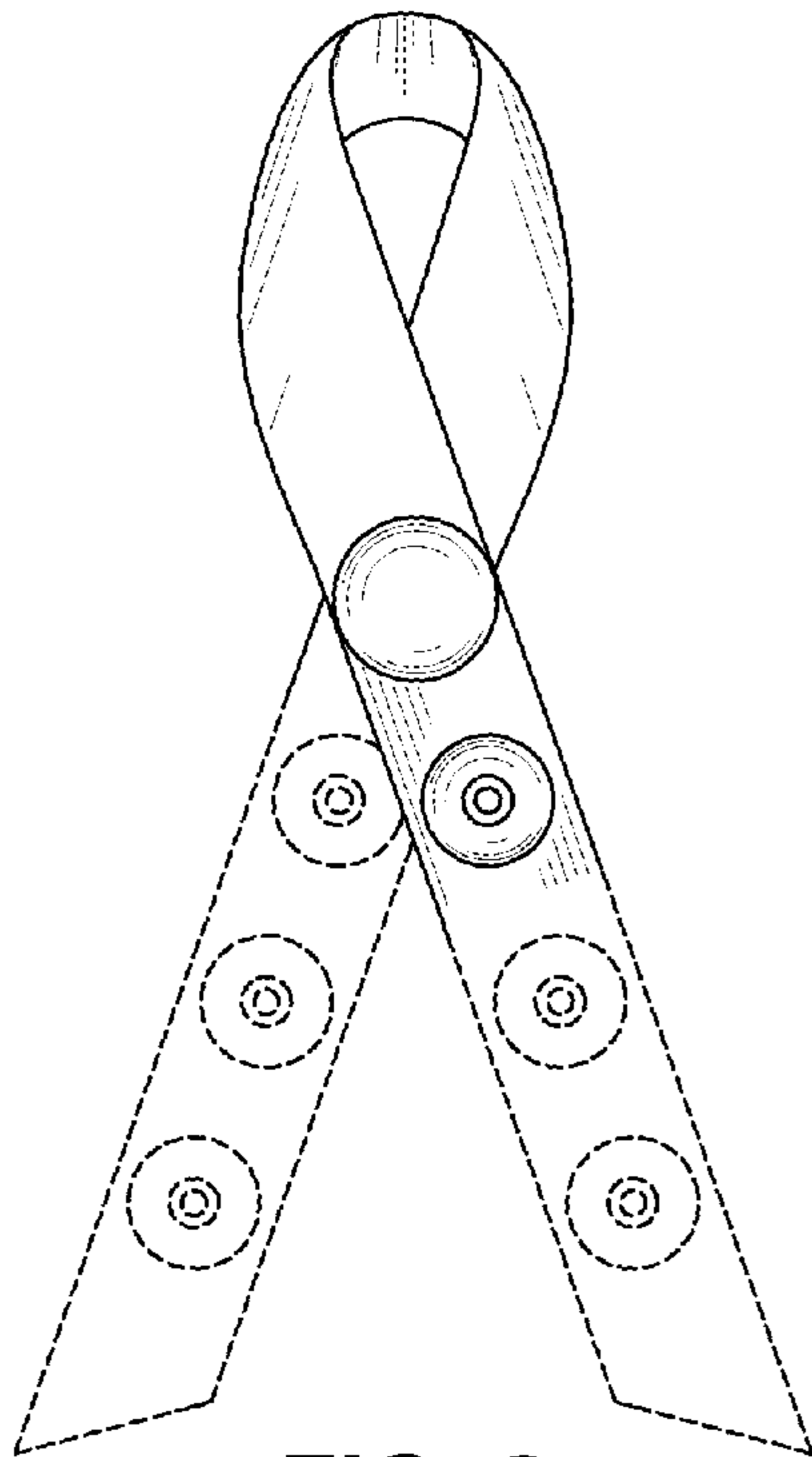

FIG. 2

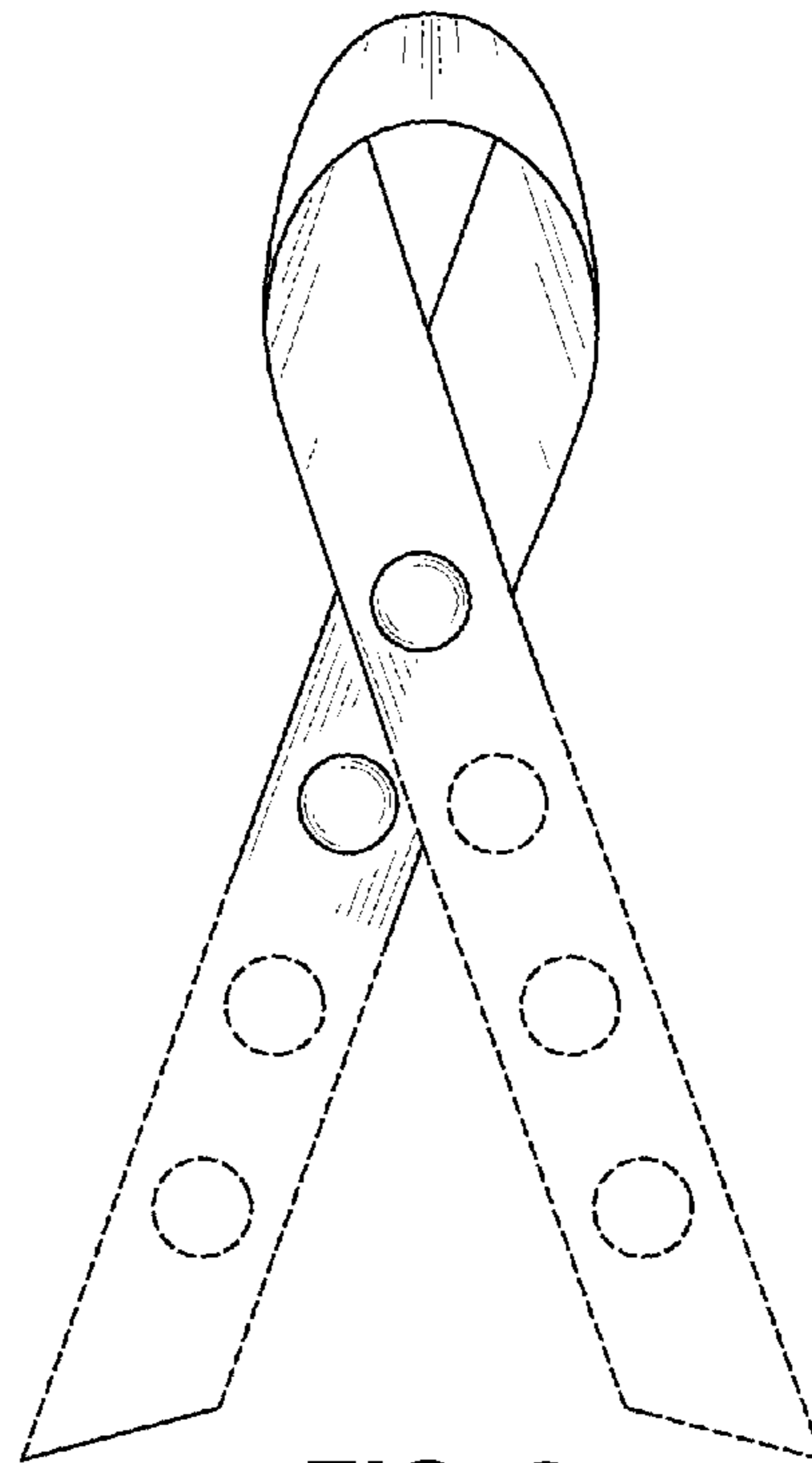

FIG. 3

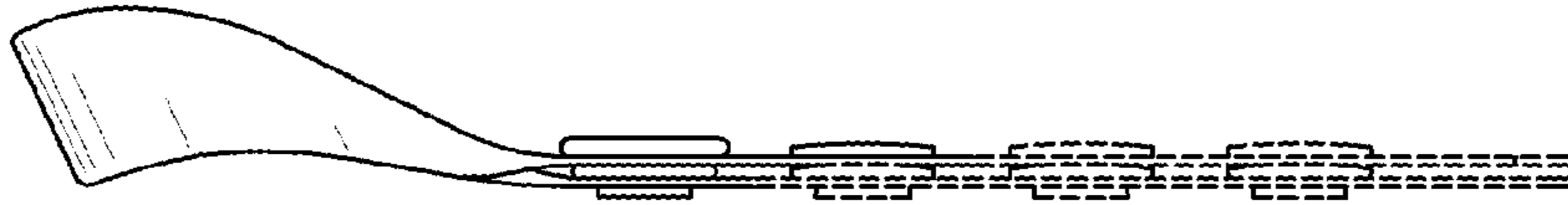

FIG. 4



FIG. 5



FIG. 6



FIG. 7