



US00D764331S

(12) **United States Design Patent**
Teranishi et al.

(10) **Patent No.:** **US D764,331 S**

(45) **Date of Patent:** **** Aug. 23, 2016**

- (54) **PROBE PIN**
- (71) Applicant: **OMRON Corporation**, Kyoto-shi, Kyoto (JP)
- (72) Inventors: **Hirotsada Teranishi**, Osaka (JP);
Takahiro Sakai, Moriyama (JP)
- (73) Assignee: **OMRON Corporation**, Kyoto (JP)

8,460,010 B2 * 6/2013 Kimura G01R 1/06722
439/66
8,669,774 B2 * 3/2014 Kato G01R 1/06722
324/755.01
8,808,038 B2 * 8/2014 Hwang G01R 1/06722
439/66
9,130,290 B2 * 9/2015 Sakai H01R 13/2428
D749,968 S * 2/2016 Huang D10/77
D750,987 S * 3/2016 Huang D10/80
9,322,846 B2 * 4/2016 Sakai G01R 1/06716

(**) Term: **15 Years**

(21) Appl. No.: **29/528,958**

(22) Filed: **Jun. 2, 2015**

(30) **Foreign Application Priority Data**

Dec. 4, 2014 (JP) 2014-027121

(51) **LOC (10) CL.** **10-04**

(52) **U.S. CL.**
USPC **D10/78**

(58) **Field of Classification Search**
USPC D10/78, 80; D13/133, 154
CPC G01R 1/067; G01R 1/06705; G01R
1/06711; G01R 1/06716; G01R 1/06722;
G01R 1/06727; G01R 1/06733; G01R
1/06738; G01R 1/06744; G01R 1/0675;
G01R 1/06766; G01R 1/06772; G01R
1/06777; G01R 1/06783; G01R 1/0678
See application file for complete search history.

(56) **References Cited**

U.S. PATENT DOCUMENTS

D229,184 S * 11/1973 Brown D10/103
D507,197 S * 7/2005 Sun D10/72
D662,895 S * 7/2012 Kimura D13/154
D665,744 S * 8/2012 Yamauchi D13/133
D665,745 S * 8/2012 Yamauchi D13/133
8,366,496 B2 * 2/2013 Hsu G01R 1/0466
439/66

FOREIGN PATENT DOCUMENTS

KR 30-0653160 7/2012
WO 2007/097559 A1 8/2007

OTHER PUBLICATIONS

Korean Office Action issued in KR Appl. No. 30-2015-0027089.
U.S. Appl. No. 29/528,956, filed Jun. 2, 2015; Teranishi et al.
U.S. Appl. No. 29/528,960, filed Jun. 2, 2015; Teranishi et al.

* cited by examiner

Primary Examiner — Antoine D Davis

(74) *Attorney, Agent, or Firm* — Sterne, Kessler, Goldstein & Fox P.L.L.C.

(57) **CLAIM**

The ornamental design for a probe pin, as shown and described.

DESCRIPTION

FIG. 1 is a top front perspective view of a probe pin showing our new design;
FIG. 2 is a front view thereof;
FIG. 3 is a rear view thereof;
FIG. 4 is a left side view thereof;
FIG. 5 is a right side view thereof;
FIG. 6 is a top view thereof; and,
FIG. 7 is a bottom view thereof.
The shade lines in the figures show contour and not surface ornamentation.

1 Claim, 4 Drawing Sheets

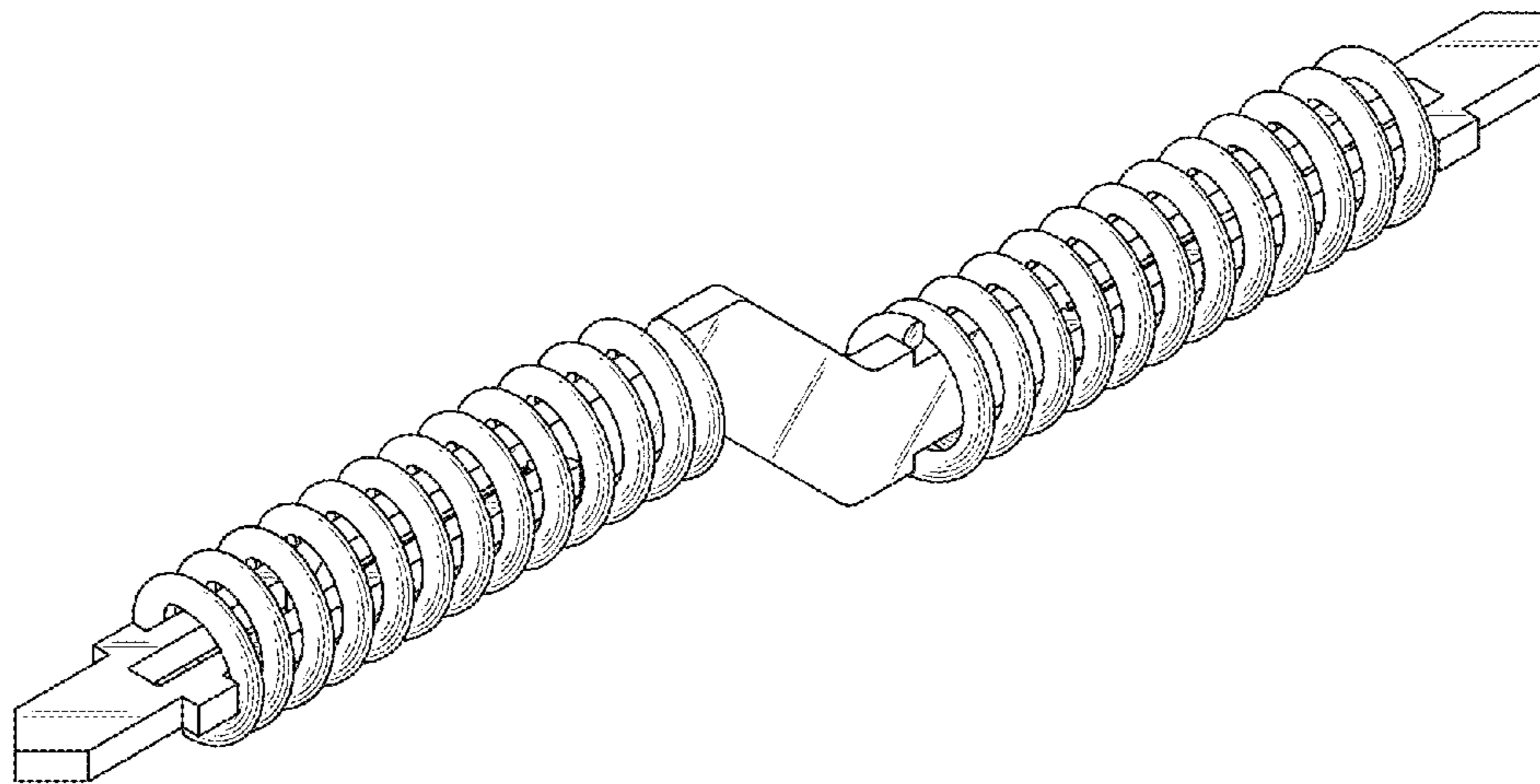

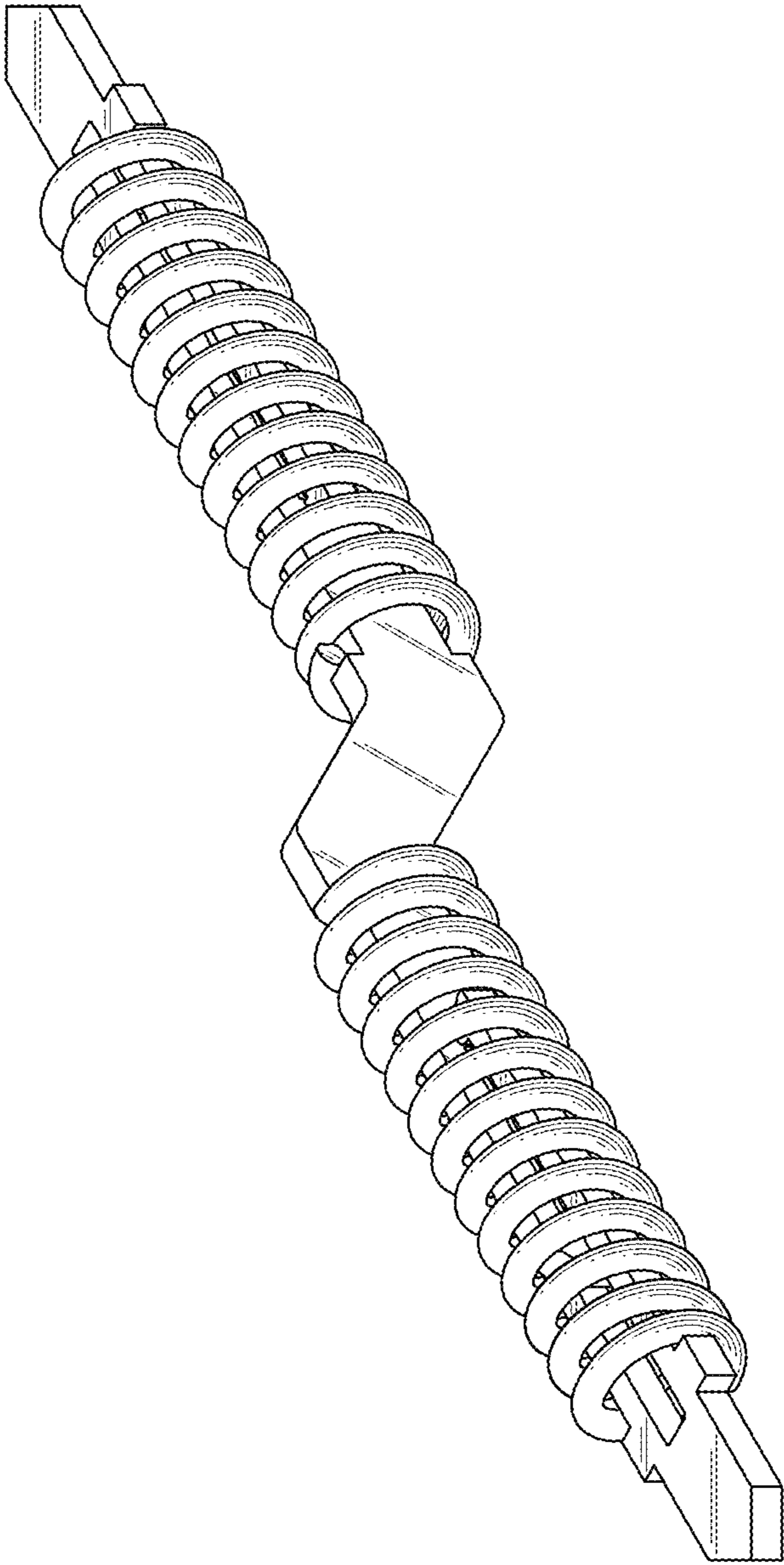

FIG. 1

FIG. 2

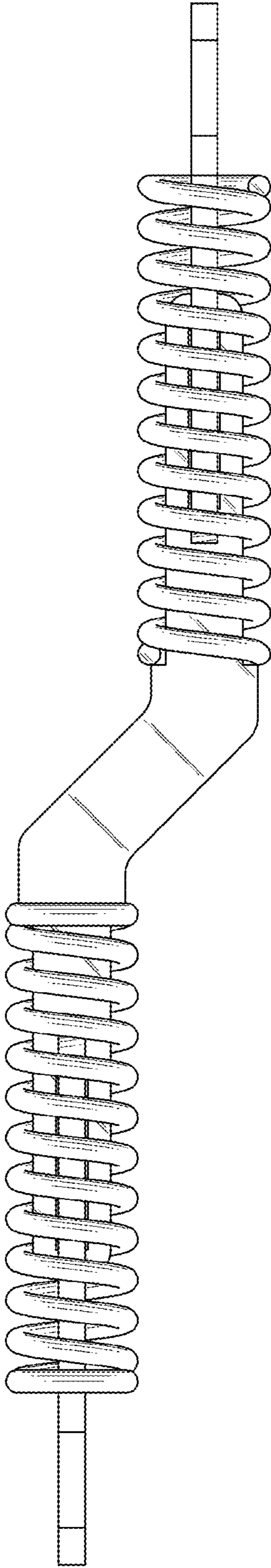
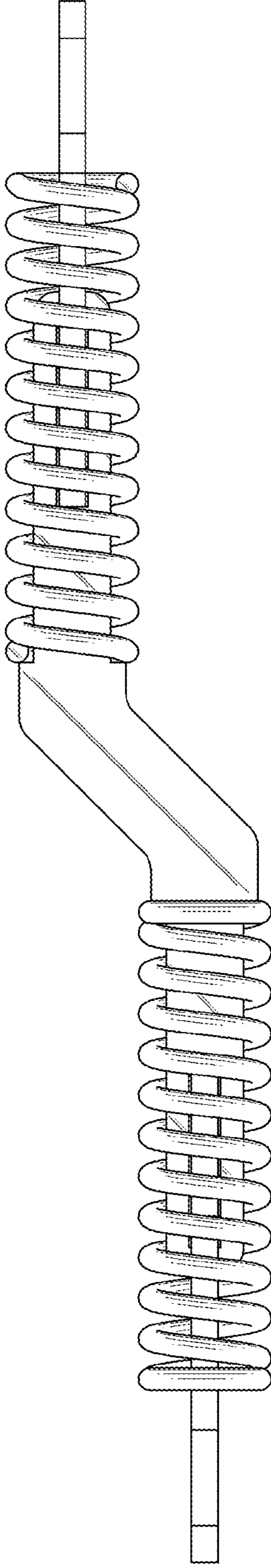

FIG. 3



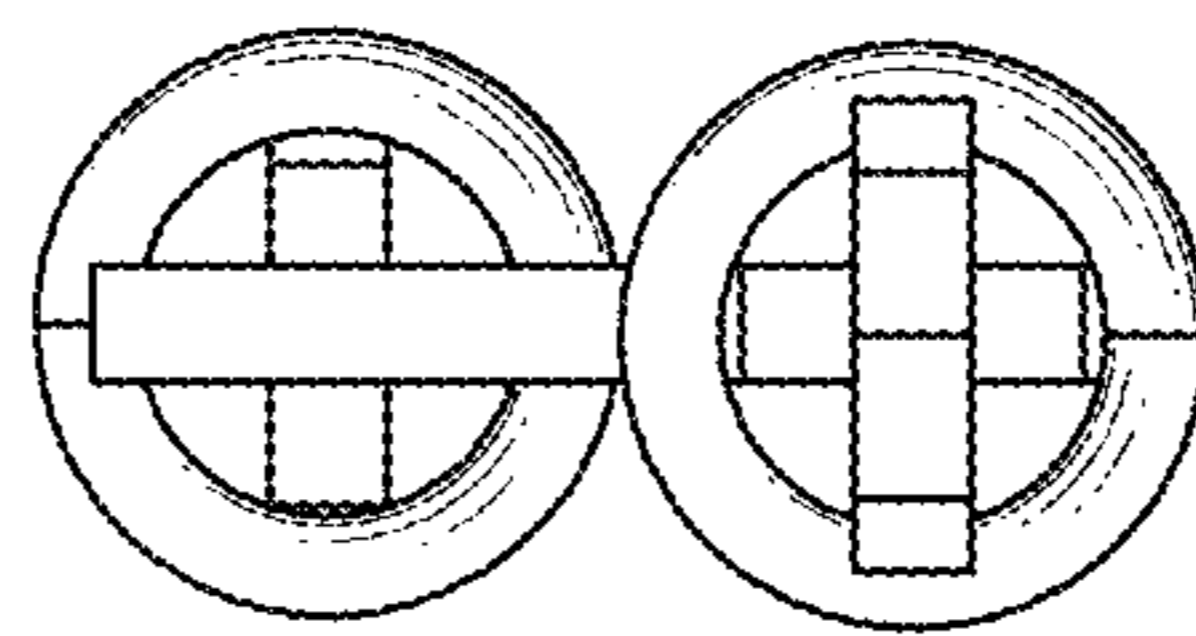

FIG. 5

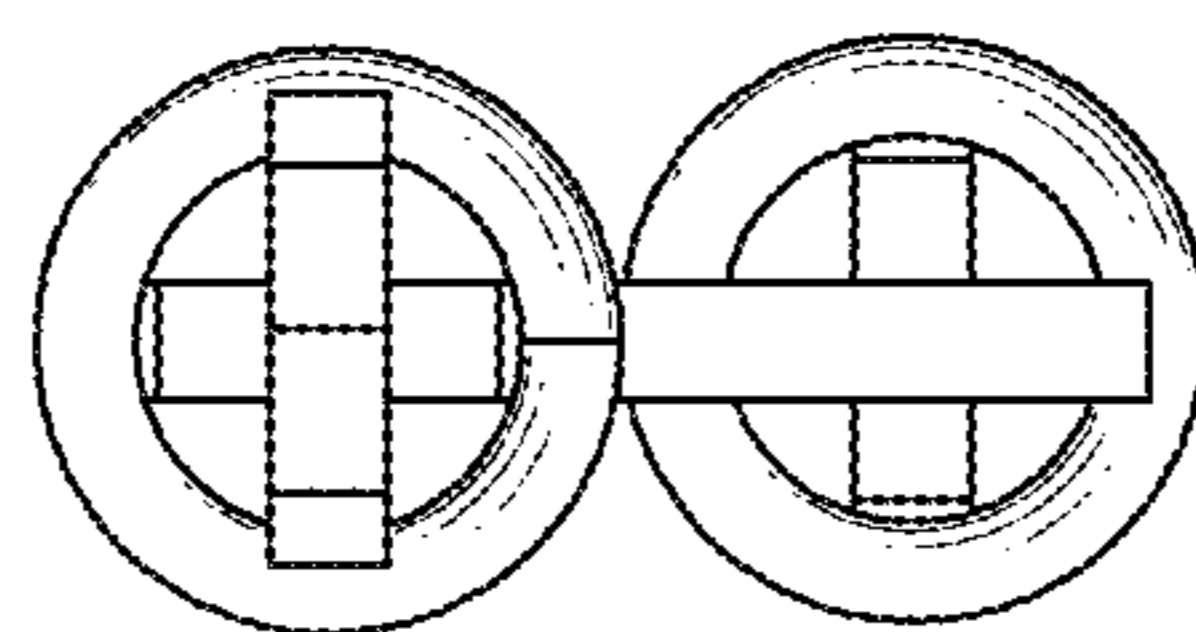

FIG. 4

FIG. 6

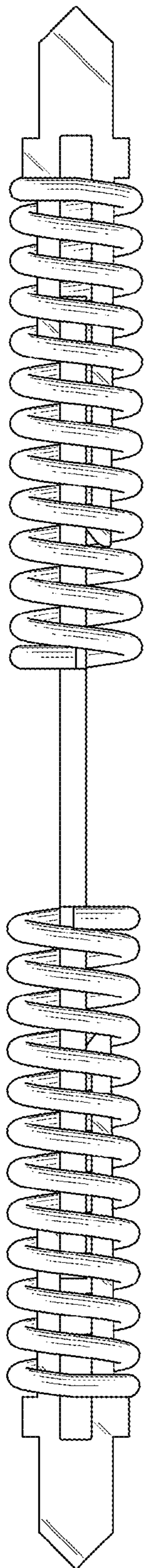

FIG. 7

