



US00D763938S

(12) **United States Design Patent**  
**Muehleemann et al.**

(10) **Patent No.:** **US D763,938 S**  
(45) **Date of Patent:** **\*\* Aug. 16, 2016**

(54) **OPTICAL SENSOR ARRAY**

5,139,025 A 8/1992 Lewis et al.  
5,217,013 A 6/1993 Lewis et al.  
5,222,496 A 6/1993 Clarke et al.

(71) Applicant: **Cephalogics, LLC**, Boston, MA (US)

(Continued)

(72) Inventors: **Thomas Muehleemann**, Zurich (CH);  
**Catherine Pace**, Lausanne (CH); **Karim Haroud**,  
Chavannes sur Moudon (CH); **Stefan Troller**,  
Sissach (CH); **Azadeh Khanicheh**, Wakefield,  
MA (US); **Michel Bruehwiler**, Newton, MA (US);  
**Russell L. Herrig**, Lexington, MA (US);  
**Jeffery J. Caputo**, Winchester, MA (US)

FOREIGN PATENT DOCUMENTS

JP D148611 \* 12/2013

OTHER PUBLICATIONS

[No Author Listed] fNIR Optical Brain Imaging Systems. Product Sheet. Biopac Systems, Inc. 5 pages. [https://www.biopac.com/Product\\_Spec\\_PDF/fNIR%20Systems.pdf](https://www.biopac.com/Product_Spec_PDF/fNIR%20Systems.pdf) [last updated Mar. 3, 2014].

(Continued)

(73) Assignee: **Cephalogics, LLC**, Boston, MA (US)

(\*\*) Term: **14 Years**

*Primary Examiner* — Susan Bennett Hattan  
*Assistant Examiner* — Leanne Was

(21) Appl. No.: **29/486,801**

(74) *Attorney, Agent, or Firm* — Wolf, Greenfield & Sacks, P.C.

(22) Filed: **Apr. 2, 2014**

(51) **LOC (10) Cl.** ..... **24-01**

(52) **U.S. Cl.**  
USPC ..... **D16/130; D24/187**

(58) **Field of Classification Search**  
USPC ..... D10/46, 64; D16/130, 134, 136;  
D24/107, 167, 168, 185, 186, 187, 200,  
D24/206, 207, 232, 233; 600/310, 324, 384,  
600/391, 393, 425; 607/142, 148, 152  
CPC . A61B 5/6801; A61B 5/1455; A61B 5/14553  
See application file for complete search history.

(57) **CLAIM**

The ornamental design for an optical sensor array, as shown and described.

**DESCRIPTION**

FIG. 1 is a front, right perspective view of the optical sensor array;  
FIG. 2 is a front view of FIG. 1;  
FIG. 3 is a back view of FIG. 1;  
FIG. 4 is a left side view of FIG. 1;  
FIG. 5 is a right side view of FIG. 1;  
FIG. 6 is a top view of FIG. 1;  
FIG. 7 is a bottom view of FIG. 1;  
FIG. 8 is a front, left perspective view of FIG. 1; and,  
FIG. 9 is a back perspective view of FIG. 1.  
The evenly spaced dashed lines depict unclaimed environment. Features shown in dashed-dot lines, such as appears, for example, in FIGS. 3 and 9, represent boundary lines.

(56) **References Cited**

U.S. PATENT DOCUMENTS

3,769,974 A 11/1973 Smart et al.  
4,281,645 A 8/1981 Jöbsis  
4,825,872 A 5/1989 Tan et al.  
4,967,038 A 10/1990 Gevins et al.  
4,972,331 A 11/1990 Chance  
5,137,355 A 8/1992 Barbour et al.

**1 Claim, 7 Drawing Sheets**

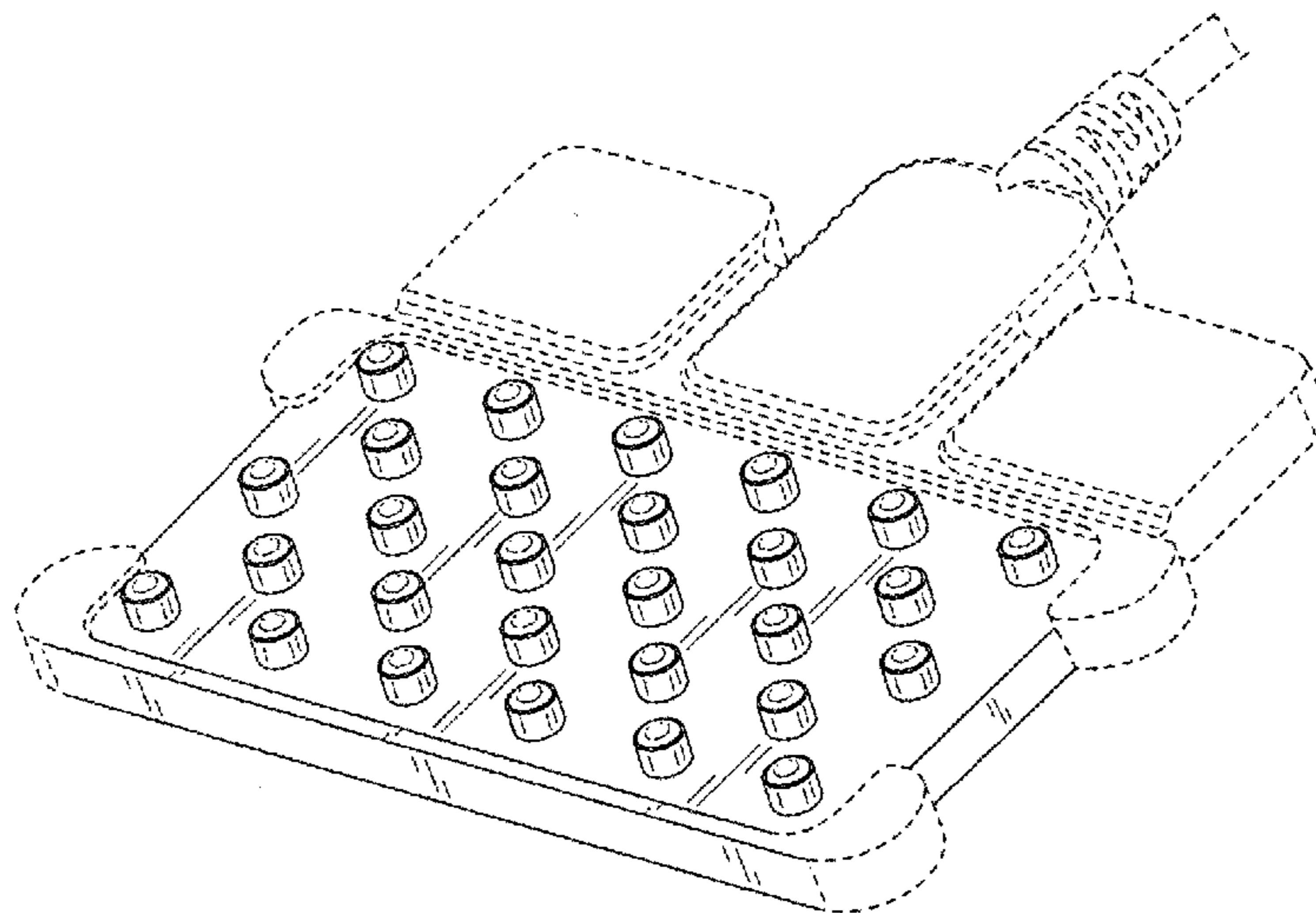

(56)

References Cited

U.S. PATENT DOCUMENTS

5,465,714 A	11/1995	Scheuing		8,095,194 B2	1/2012	Ninomiya et al.
5,482,034 A	1/1996	Lewis et al.		8,131,347 B2	3/2012	Cho et al.
5,517,987 A	5/1996	Tsuchiya		8,175,671 B2	5/2012	Hoarau
5,584,296 A	12/1996	Cui et al.		8,190,225 B2	5/2012	Hoarau
5,596,987 A	1/1997	Chance		8,798,702 B2 *	8/2014	Trumble ..... A61B 5/14551 600/310
5,664,574 A	9/1997	Chance		8,821,397 B2 *	9/2014	Al-Ali ..... 600/301
5,792,051 A	8/1998	Chance		8,849,369 B2 *	9/2014	Cogan ..... A61B 5/0006 600/378
5,800,349 A	9/1998	Isaacson et al.		D723,701 S *	3/2015	Maki ..... D24/187
5,803,909 A	9/1998	Maki et al.		2004/0064052 A1	4/2004	Chance et al.
5,820,558 A	10/1998	Chance		2007/0260129 A1 *	11/2007	Chin ..... A61B 5/02411 600/323
5,835,617 A	11/1998	Ohta et al.		2008/0154126 A1	6/2008	Culver et al.
5,853,370 A	12/1998	Chance et al.		2008/0177163 A1	7/2008	Wang et al.
5,873,821 A	2/1999	Chance et al.		2008/0228053 A1	9/2008	Wang et al.
5,902,235 A	5/1999	Lewis et al.		2008/0242958 A1 *	10/2008	Al-Ali ..... A61B 5/02427 600/323
5,987,351 A	11/1999	Chance		2008/0316488 A1	12/2008	Mao et al.
6,075,610 A	6/2000	Ueda et al.		2009/0108205 A1	4/2009	Duffy et al.
6,078,833 A	6/2000	Hueber		2009/0234245 A1	9/2009	Jaffe et al.
6,192,261 B1	2/2001	Gratton et al.		2009/0259114 A1 *	10/2009	Johnson ..... A61B 5/14552 600/310
6,240,309 B1	5/2001	Yamashita et al.		2009/0281403 A1	11/2009	Benni
6,272,367 B1	8/2001	Chance		2009/0292210 A1	11/2009	Culver et al.
6,282,438 B1	8/2001	Maki et al.		2009/0326345 A1	12/2009	Jaffe et al.
6,304,767 B1	10/2001	Soller et al.		2010/0049018 A1	2/2010	Duffy et al.
6,335,792 B1	1/2002	Tsuchiya		2010/0174160 A1	7/2010	Chance
6,397,099 B1 *	5/2002	Chance ..... A61B 5/0059 600/323		2010/0198029 A1	8/2010	Wang
6,456,862 B2	9/2002	Benni		2010/0222654 A1 *	9/2010	Gonopolskiy ..... A61B 5/6833 600/310
6,516,209 B2	2/2003	Cheng et al.		2010/0241006 A1	9/2010	Choi et al.
6,542,763 B1	4/2003	Yamashita et al.		2010/0249608 A1	9/2010	Chance
6,549,284 B1	4/2003	Boas et al.		2010/0317949 A1	12/2010	Chamness et al.
6,577,884 B1	6/2003	Boas		2010/0331640 A1 *	12/2010	Medina ..... A61B 5/14535 600/324
6,587,703 B2	7/2003	Cheng et al.		2011/0046459 A1	2/2011	Zhang et al.
6,597,931 B1	7/2003	Cheng et al.		2011/0060197 A1	3/2011	Zhang et al.
6,611,698 B1	8/2003	Yamashita et al.		2011/0176217 A1 *	7/2011	Fujii ..... G02B 3/0056 359/619
6,615,065 B1	9/2003	Barrett et al.		2011/0190613 A1	8/2011	Zhang et al.
6,618,614 B1	9/2003	Chance		2011/0205535 A1	8/2011	Soller et al.
6,795,195 B1	9/2004	Barbour et al.		2011/0264411 A1	10/2011	Yang et al.
6,901,284 B1	5/2005	Maki et al.		2012/0253153 A1 *	10/2012	Trumble ..... A61B 5/14551 600/324
6,937,884 B1	8/2005	Barbour		2013/0079609 A1 *	3/2013	Besko ..... A61B 5/14552 600/324
RE38,800 E	9/2005	Barbour		2013/0079611 A1 *	3/2013	Besko ..... A61B 5/14552 600/344
6,947,779 B2	9/2005	Yamamoto et al.		2013/0144365 A1 *	6/2013	Kipke ..... A61B 5/04001 607/93
7,034,303 B2	4/2006	Schotland et al.		2013/0158372 A1 *	6/2013	Haisley ..... A61B 5/1455 600/310
7,047,054 B2	5/2006	Benni		2014/0012108 A1 *	1/2014	McPeak ..... A61B 5/0295 600/324
7,142,304 B1	11/2006	Barbour et al.		2014/0031793 A1 *	1/2014	Constantineau .. A61M 5/14248 604/510
7,197,357 B2	3/2007	Istvan et al.		2014/0180046 A1 *	6/2014	Campbell ..... A61B 5/0205 600/324
7,248,909 B2	7/2007	Lee et al.		2014/0276013 A1 *	9/2014	Muehlemann ..... A61B 5/0013 600/425
7,286,870 B2	10/2007	Maki et al.		2014/0276014 A1 *	9/2014	Khanicheh ..... A61B 5/0013 600/425
7,313,427 B2	12/2007	Benni		2015/0157225 A1 *	6/2015	Gillberg ..... A61B 5/04085 600/393
7,355,688 B2	4/2008	Lash et al.				
D568,479 S *	5/2008	Mao ..... D24/168				
7,440,794 B2	10/2008	Maki et al.				
7,463,362 B2	12/2008	Lasker et al.				
7,477,924 B2 *	1/2009	Chin ..... A61B 5/02411 600/323				
7,503,927 B1 *	3/2009	Vetanze ..... A61N 1/0408 607/115				
7,538,865 B2	5/2009	Lash et al.				
D594,127 S *	6/2009	Causevic ..... D24/187				
7,551,950 B2	6/2009	Cheng				
7,576,853 B2	8/2009	Barbour				
7,610,082 B2	10/2009	Chance				
7,643,858 B2	1/2010	Agashe et al.				
7,676,253 B2	3/2010	Raridan, Jr.				
7,740,588 B1	6/2010	Sciarra				
7,741,592 B1	6/2010	Gonopolskiy et al.				
7,761,127 B2	7/2010	Al-Ali et al.				
7,774,047 B2	8/2010	Yamashita et al.				
7,778,694 B2	8/2010	Kaga et al.				
RE41,949 E	11/2010	Barbour et al.				
7,869,849 B2	1/2011	Ollerdessen et al.				
7,880,884 B2	2/2011	Medina				
7,979,102 B2	7/2011	Hannula et al.				
7,983,740 B2	7/2011	Culver et al.				
8,040,519 B2	10/2011	Kawasaki et al.				
8,050,744 B2	11/2011	Maki et al.				
8,060,189 B2	11/2011	Ben Dor et al.				

OTHER PUBLICATIONS

[No Author Listed] NEW Functional Near Infrared Systems to Study Brain Activity: Emerging fNIR technology monitors cortical hemodynamic changes to brain activation and provides objective real-time response data. Biopac Systems, Inc. 2 pages. <http://www.biopac.com/Manuals/fnir%20product%20sheet.pdf>. [last accessed Mar. 28, 2012].

Bozkurt et al., A portable near infrared spectroscopy system for bedside monitoring of newborn brain. Biomed Eng Online. 2005;4(29). 11 pages.

Cohn, Near-Infrared Spectroscopy: Potential Clinical Benefits in Surgery. J Am Coll Surg. Aug. 2007;205(2):322-32.

(56)

**References Cited**

## OTHER PUBLICATIONS

Culver et al., Diffuse Optical Tomography of Cerebral Blood Flow, Oxygenation, and Metabolism in Rat During Focal Ischemia. *J Cereb Blood Flow Metab.* 2003;23(8):911-24.

Curtin et al., Functional near-infrared spectroscopy for the measurement of propofol effects in conscious sedation during outpatient elective colonoscopy. *NeuroImage.* 2013. 11 pages. <http://dx.doi.org/10.1016/j.neuroimage.2013.07.009> [last accessed Mar. 28, 2012].

Dam et al., Fiber-optic probe for noninvasive real-time determination of tissue optical properties at multiple wavelengths. *Appl Optics.* Mar. 1, 2001;40(7):1155-64.

Fantini et al., Frequency-domain multichannel optical detector for noninvasive tissue spectroscopy and oximetry. *Opt Eng.* Jan. 1995;34(1):32-42.

Ferradal et al., Bedside Monitoring of Cerebral Oxygenation Using DOT. *Biomed Optics. BIOMED/DH Joint Poster Session.* Apr. 11-14, 2010. 3 pages.

Franceschini et al., Optical Study of the Skeletal Muscle During Exercise with a Second Generation Frequency-Domain Tissue Oximeter. 1997;807-814.

Gratton et al., Measurement of brain activity by near-infrared light. *J Biomed Optics.* Jan./Feb. 2005;10(1):011008.1-13.

Liao et al., Neonatal hemodynamic response to visual cortex activity: high-density near-infrared spectroscopy study. *J Biomed Optics.* Mar./Apr. 2010;15(2):026010.1-9.

Mühlemann, A Novel wireless Near-Infrared Spectrophotometer Applied to Measure Cortical Haemodynamics in Humans and Sheep. *ETH Dissertation No. 19051.* ETH Zurich. 2010. 112 pages.

Nishimura et al., A New Approach to Functional Near-Infrared Technology. *IEEE Eng Med Biol Mag.* Jul./Aug. 2007;26(4):25-9.

Shah et al., Noninvasive functional optical spectroscopy of human breast tissue. *PNAS.* Apr. 10, 2001;98(8):4420-5.

Shiga et al., Development of a portable tissue oximeter using near infra-red spectroscopy. *Med & Biol Eng & Comput.* Jul. 1995;33:622-6.

Taber et al., Optical Imaging: A New Window to the Adult Brain. *J Neuropsychiatry Clin Neurosci.* 2010 Fall;22(4):356-60.

Vaithianathan et al., Design of a portable near infrared system for topographic imaging of the brain in babies. *Rev Sci Instrum.* Oct. 2004;75(10):3276-83.

White et al., Phase-encoded retinotopy as an evaluation of diffuse optical neuroimaging. *NeuroImage.* 2010;49:568-77.

White et al., Quantitative evaluation of high-density diffuse optical tomography: in vivo resolution and mapping performance *J Biomed Optics.* Mar./Apr. 2010;15(2):026006.1-14.

White et al., Resting-state functional connectivity in the human brain revealed with diffuse optical tomography. *NeuroImage.* 2009;47:148-56.

Zeit, et al., Retinotopic mapping of adult human visual cortex with high-density diffuse optical tomography. *PNAS.* Jul. 17, 2007;104(29):12169-74.

U.S. Appl. No. 29/486,804, filed Apr. 2, 2014, Khanicheh et al.

\* cited by examiner

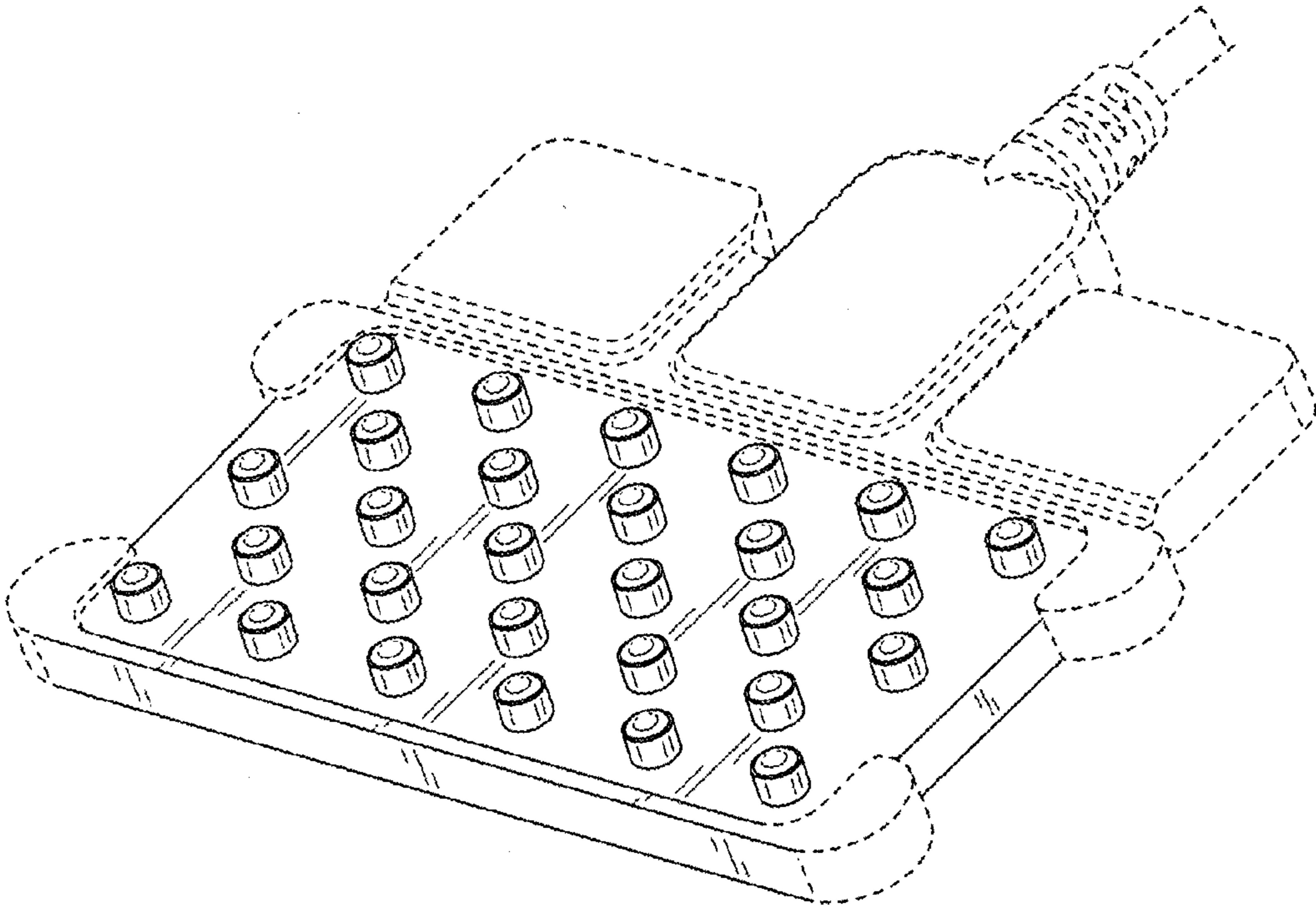

FIG. 1

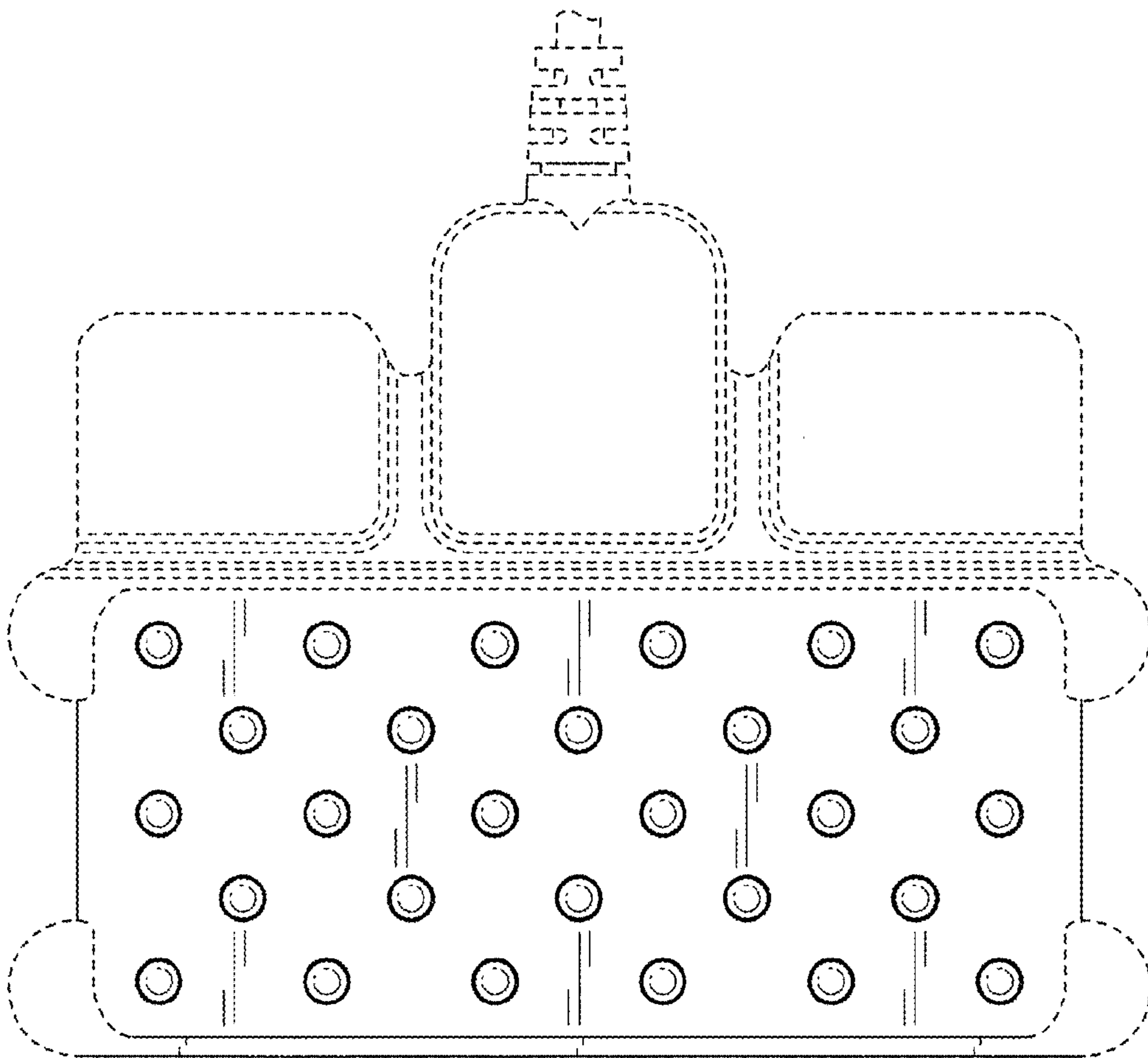

FIG. 2

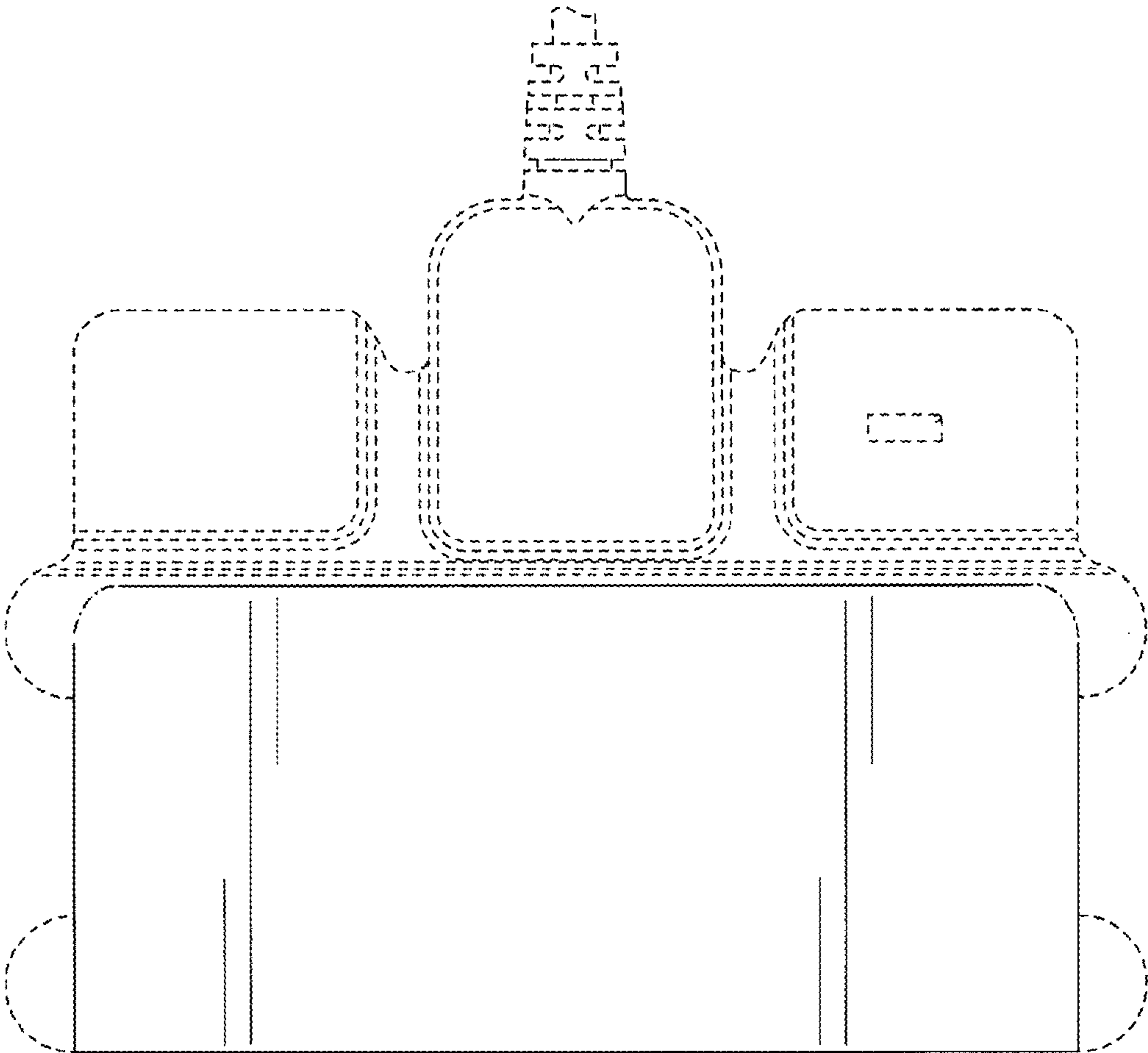

FIG. 3



FIG. 4



FIG. 5

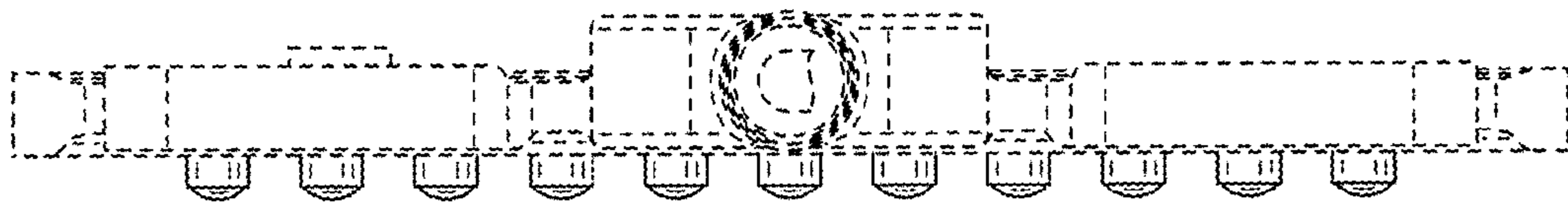

FIG. 6

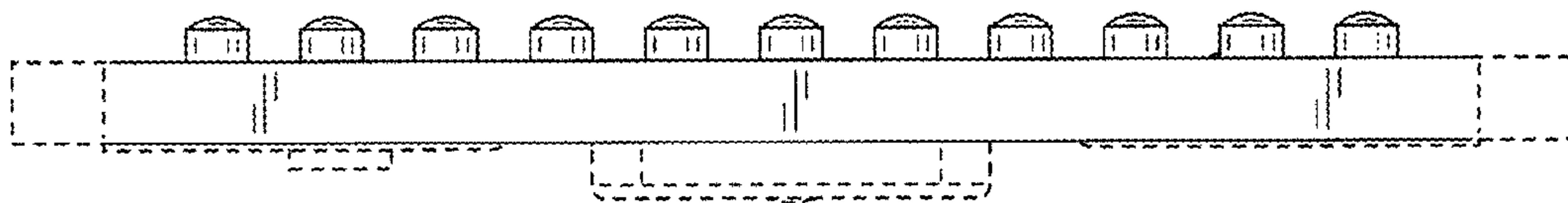

FIG. 7



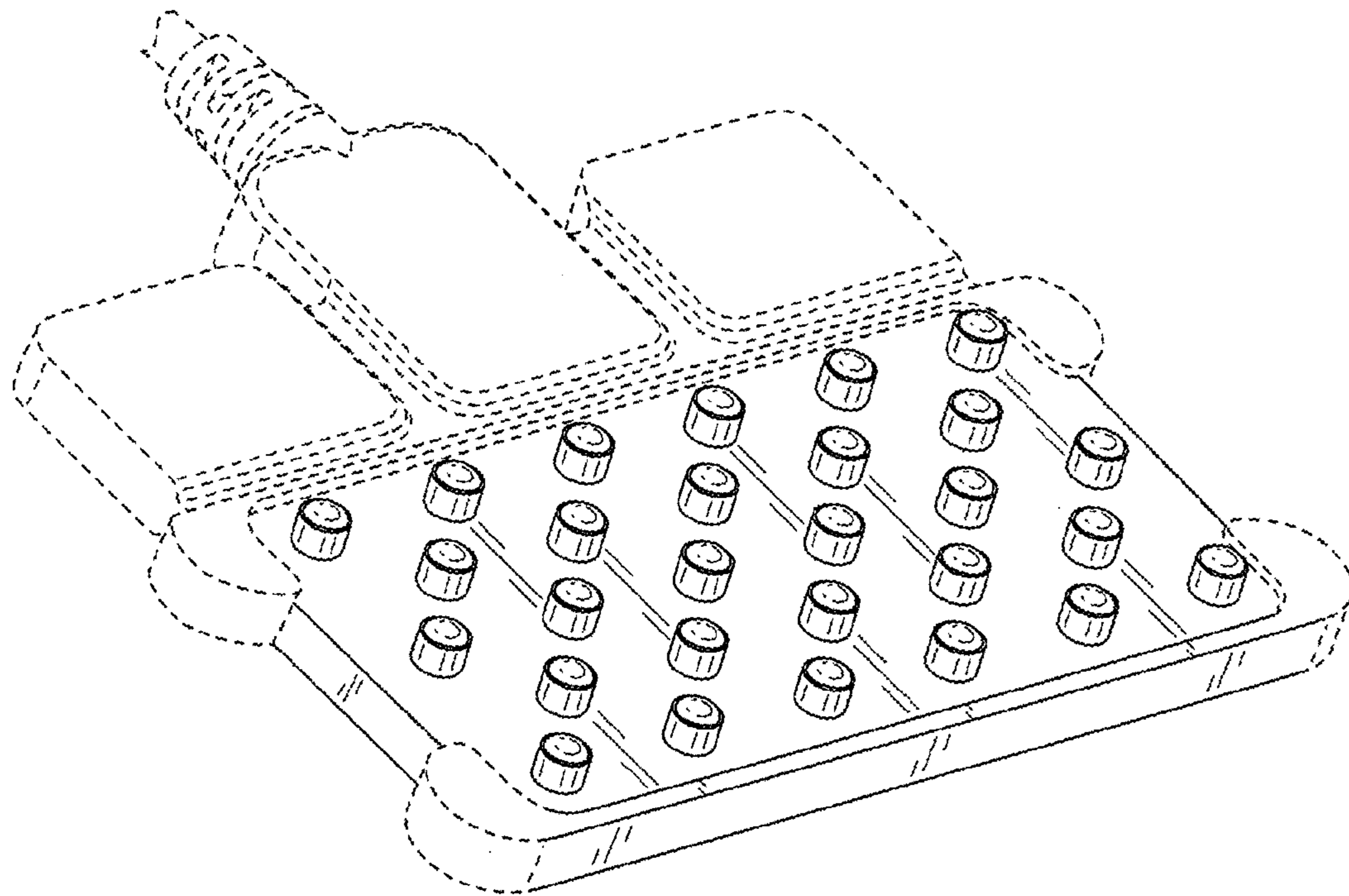

FIG. 8

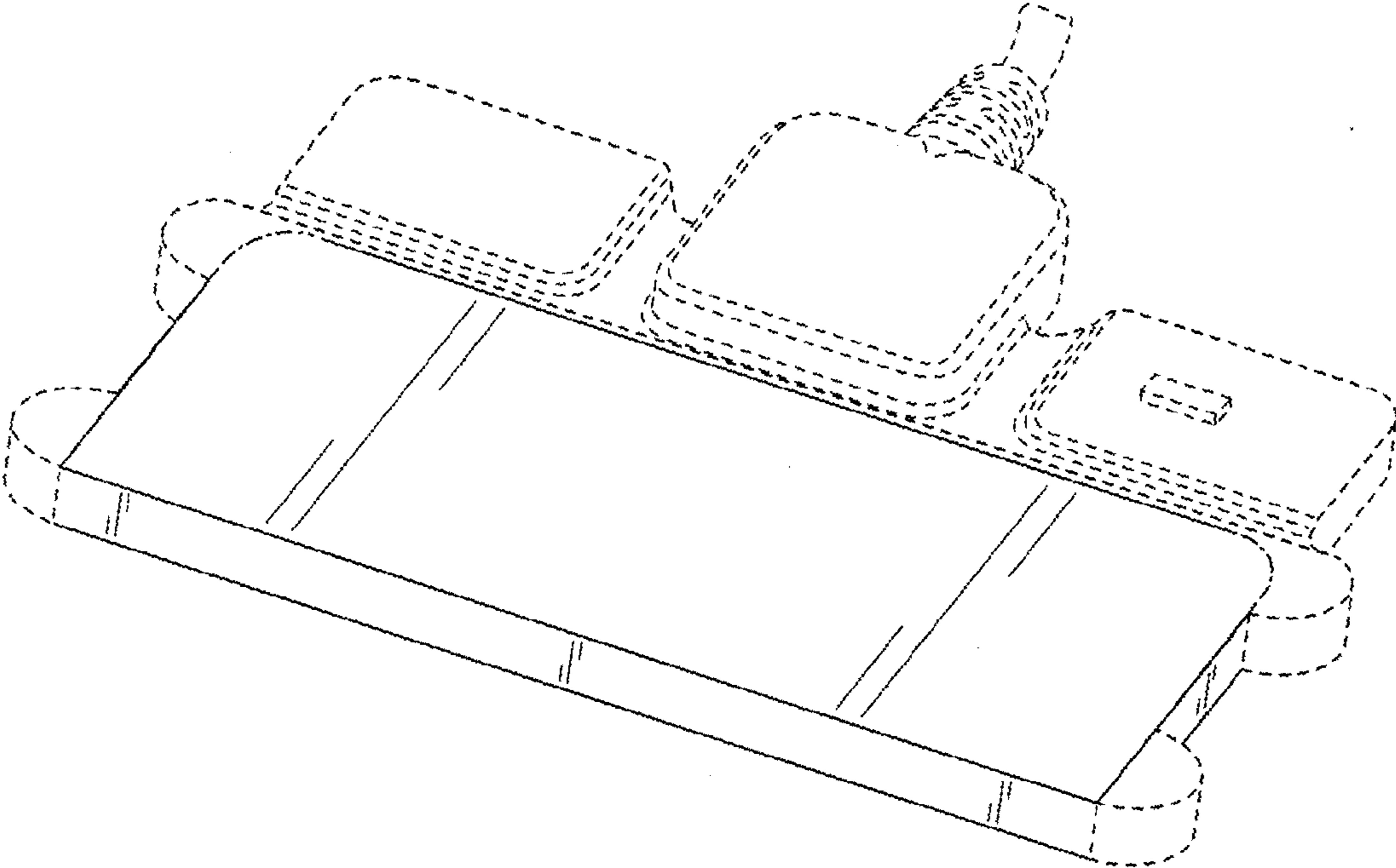

FIG. 9