



US00D763731S

(12) **United States Design Patent**
Okuyama et al.

(10) **Patent No.:** **US D763,731 S**

(45) **Date of Patent:** **** Aug. 16, 2016**

(54) **UTILITY VEHICLE**

(56) **References Cited**

(71) Applicant: **YANMAR CO., LTD.**, Osaka-shi, Osaka (JP)

U.S. PATENT DOCUMENTS

(72) Inventors: **Kiyoyuki Okuyama**, Yamagata (JP);
Masaaki Yamashita, Osaka (JP);
Tsuyoshi Kawakami, Osaka (JP);
Daisuke Hirata, Osaka (JP)

D642,493	S	*	8/2011	Goebert	D12/87
D675,960	S	*	2/2013	Hashimoto	D12/87
D682,738	S	*	5/2013	Li	D12/14
8,567,846	B1	*	10/2013	Stevens	B60N 2/36 296/183.1
8,585,088	B1	*	11/2013	Kaku	B62D 21/06 280/756
D699,627	S	*	2/2014	Tang	D12/14
D700,869	S	*	3/2014	Sato	D12/14
8,714,618	B1	*	5/2014	Heit	B60P 3/423 296/64
D709,798	S	*	7/2014	Matsumura	D12/14
8,864,174	B2	*	10/2014	Minami	B60N 2/36 280/756
D717,695	S	*	11/2014	Matsumura	D12/14

(73) Assignee: **Yanmar Co., Ltd.**, Osaka-shi (JP)

(**) Term: **14 Years**

(21) Appl. No.: **29/526,382**

(22) Filed: **May 8, 2015**

(30) **Foreign Application Priority Data**

Nov. 11, 2014 (JP) D2014-25176

(51) **LOC (10) Cl.** **12-13**

(52) **U.S. Cl.**
USPC **D12/14**

(58) **Field of Classification Search**
USPC D12/1, 2, 13, 12, 15, 14, 16, 86, 87, 3,
D12/4, 5, 85, 107, 110, 173; D21/14, 424,
D21/433, 803; D15/30; 296/1.01, 24.33,
296/181.1, 181.2, 181.4, 187.01, 187.09,
296/187.11, 187.12, 190.08, 192, 193.05,
296/193.11, 181.5; 280/183-185, DIG. 5, 1,
280/16, 82, 88, 90, 14, 756; 180/233, 908,
180/89.1, 89.11, 6.5
CPC B62D 35/00; B62D 39/00; B62D 47/00;
B62D 47/003; B62D 63/02; B62D 33/0617;
B62D 33/00; A01B 59/02; B60L 2200/22;
B60Y 2200/86; B60Y 2200/91; B60R 21/13
See application file for complete search history.

* cited by examiner

Primary Examiner — T. Chase Nelson

Assistant Examiner — Ania Aman

(74) *Attorney, Agent, or Firm* — Sterne, Kessler, Goldstein & Fox P.L.L.C.

(57) **CLAIM**

The ornamental design for a utility vehicle, as shown and described.

DESCRIPTION

FIG. 1 is a front perspective view of a utility vehicle showing our new design;
FIG. 2 is a right side view thereof;
FIG. 3 is a left side view thereof;
FIG. 4 is a top plan view thereof;
FIG. 5 is a bottom plan view thereof;
FIG. 6 is a front view thereof; and,
FIG. 7 is a rear view thereof.
The broken lines in the figures show portions of the utility vehicle that form no part of the claimed design.

1 Claim, 7 Drawing Sheets

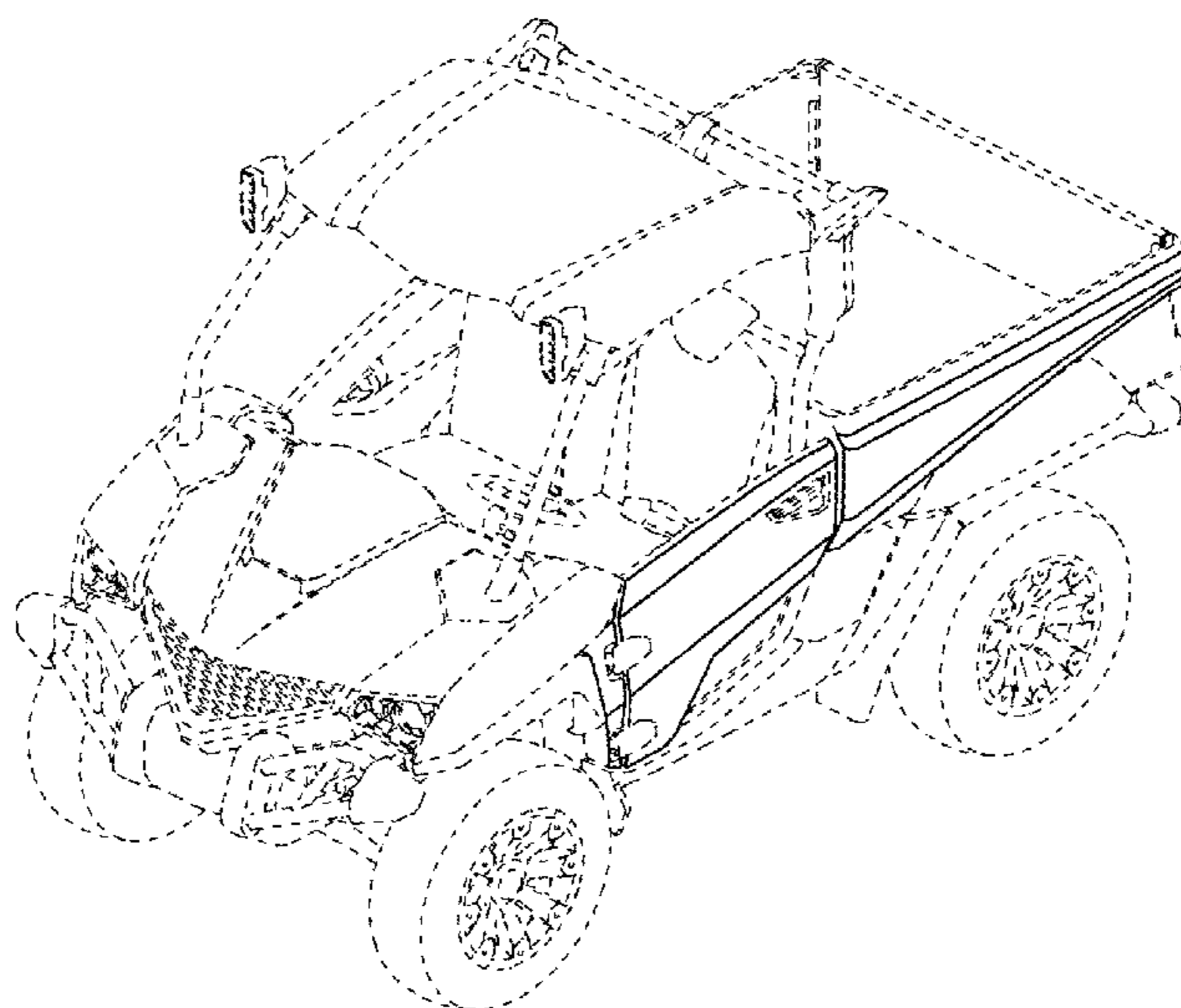

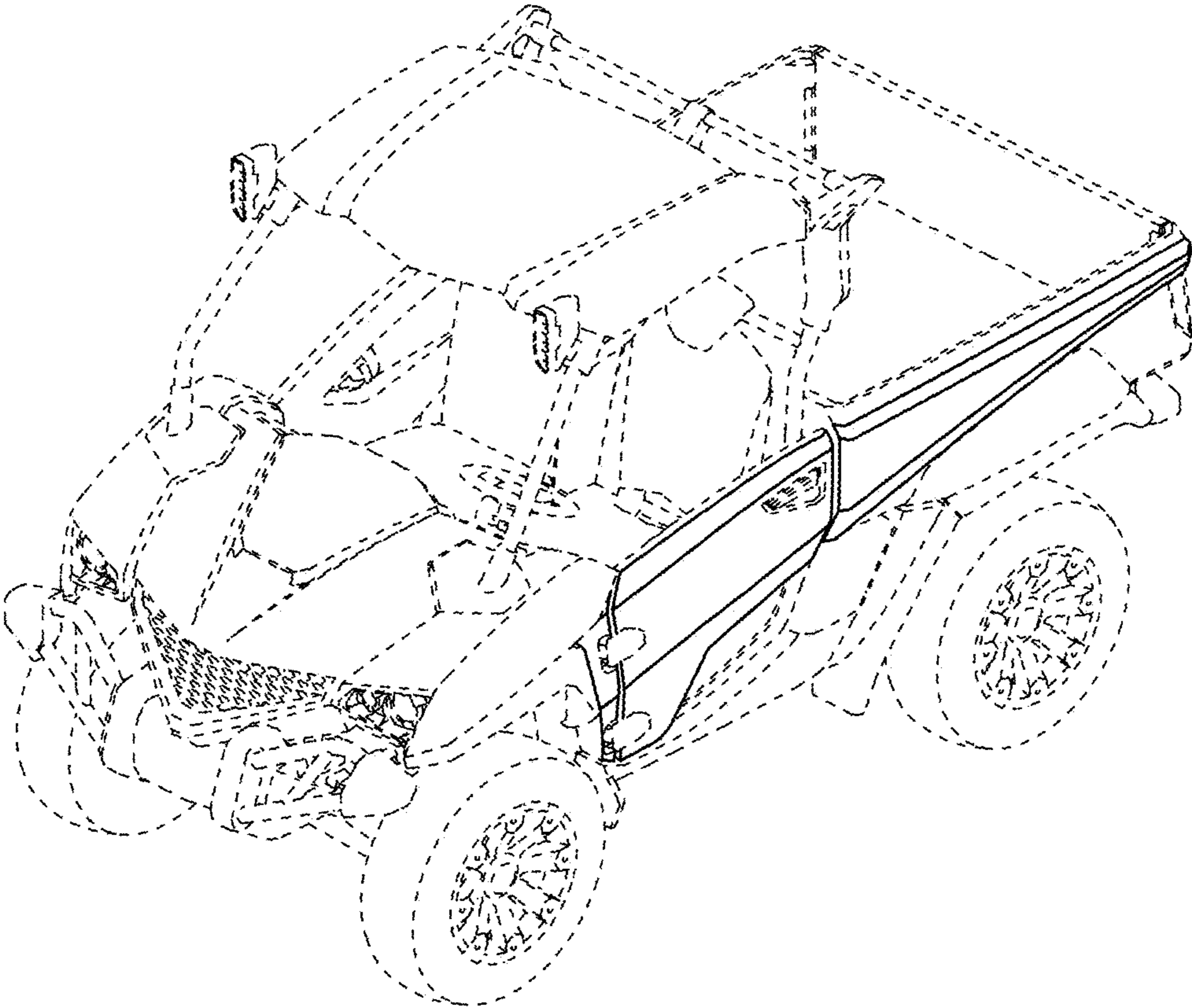

FIG. 1

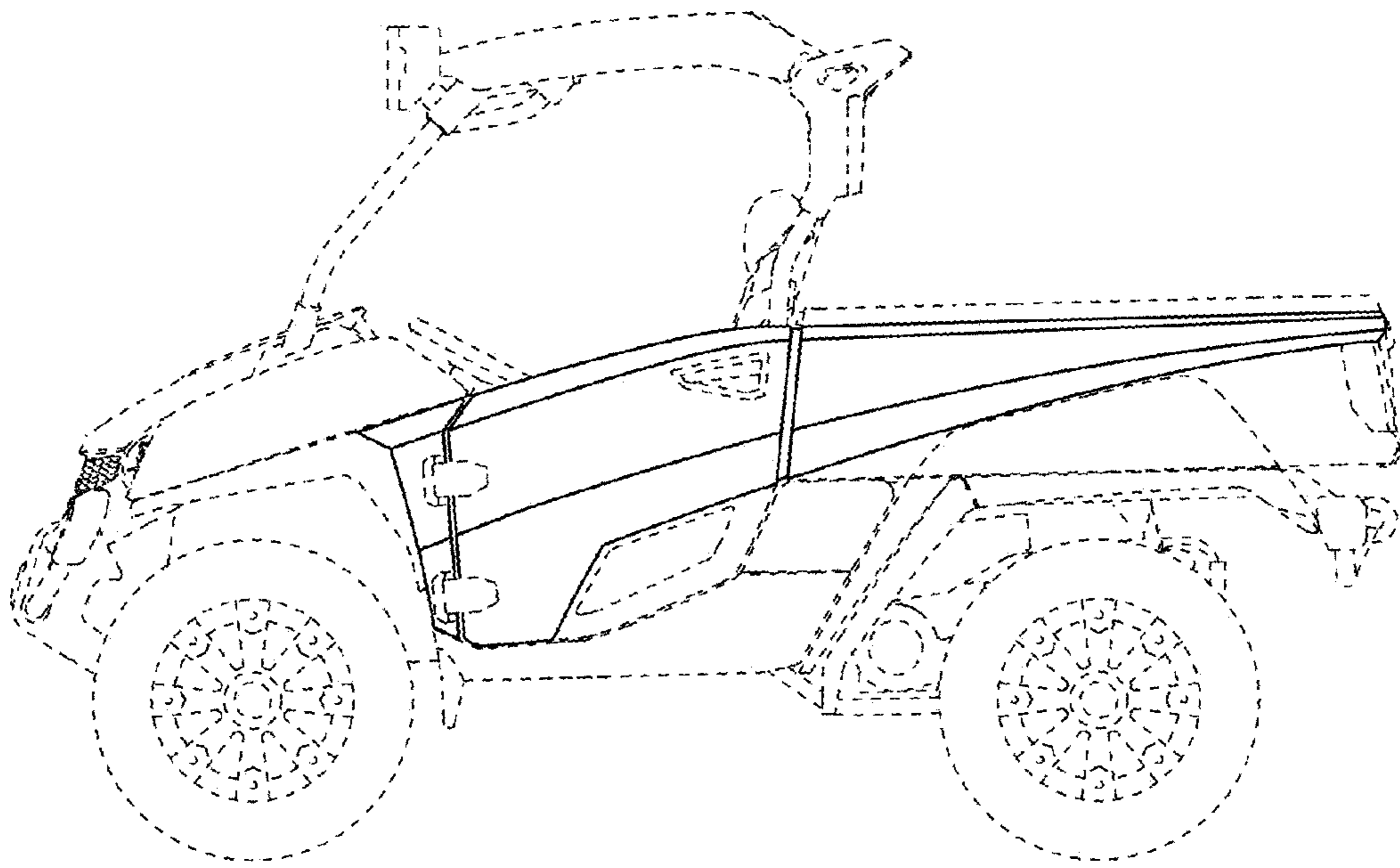

FIG. 2

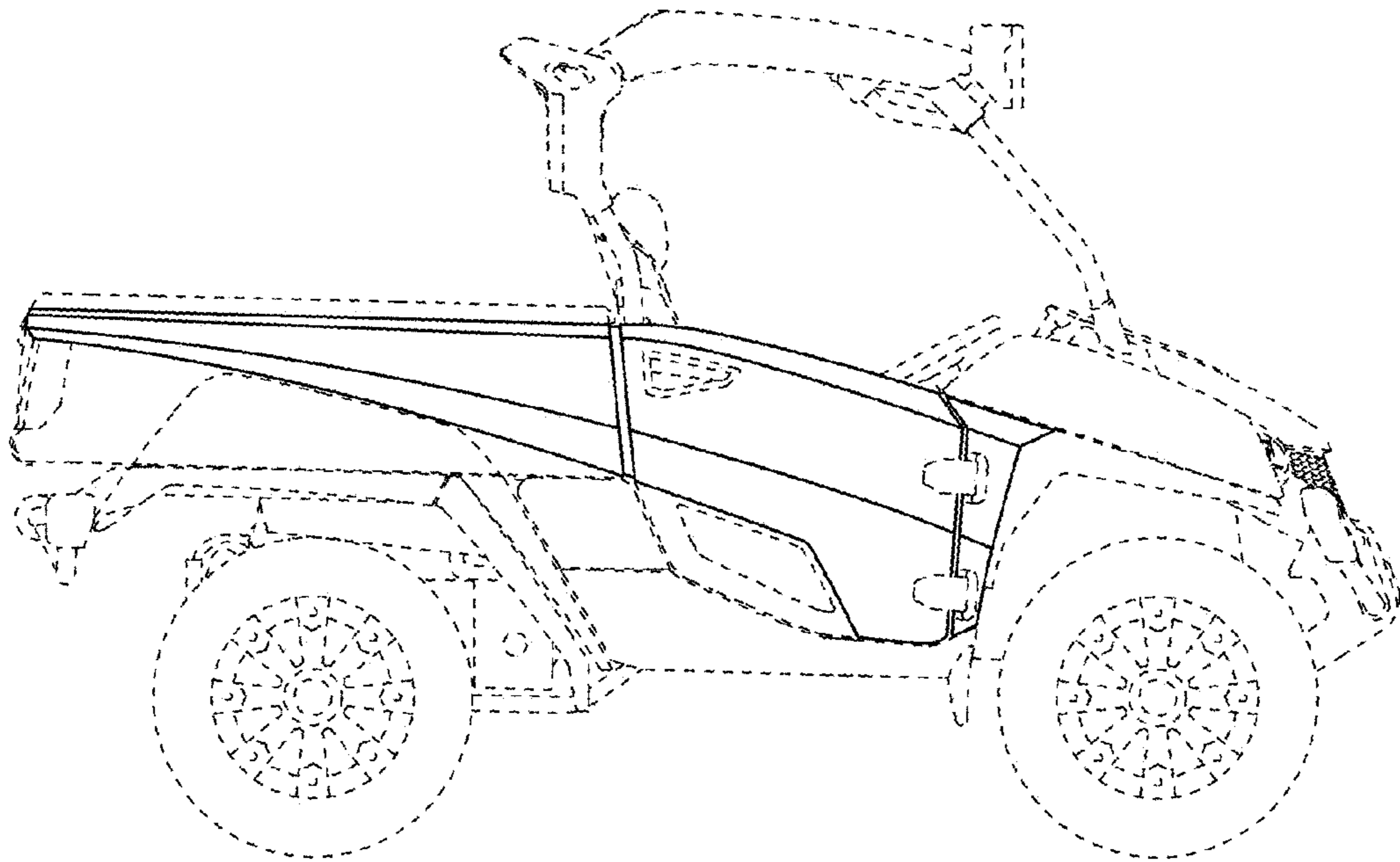

FIG. 3

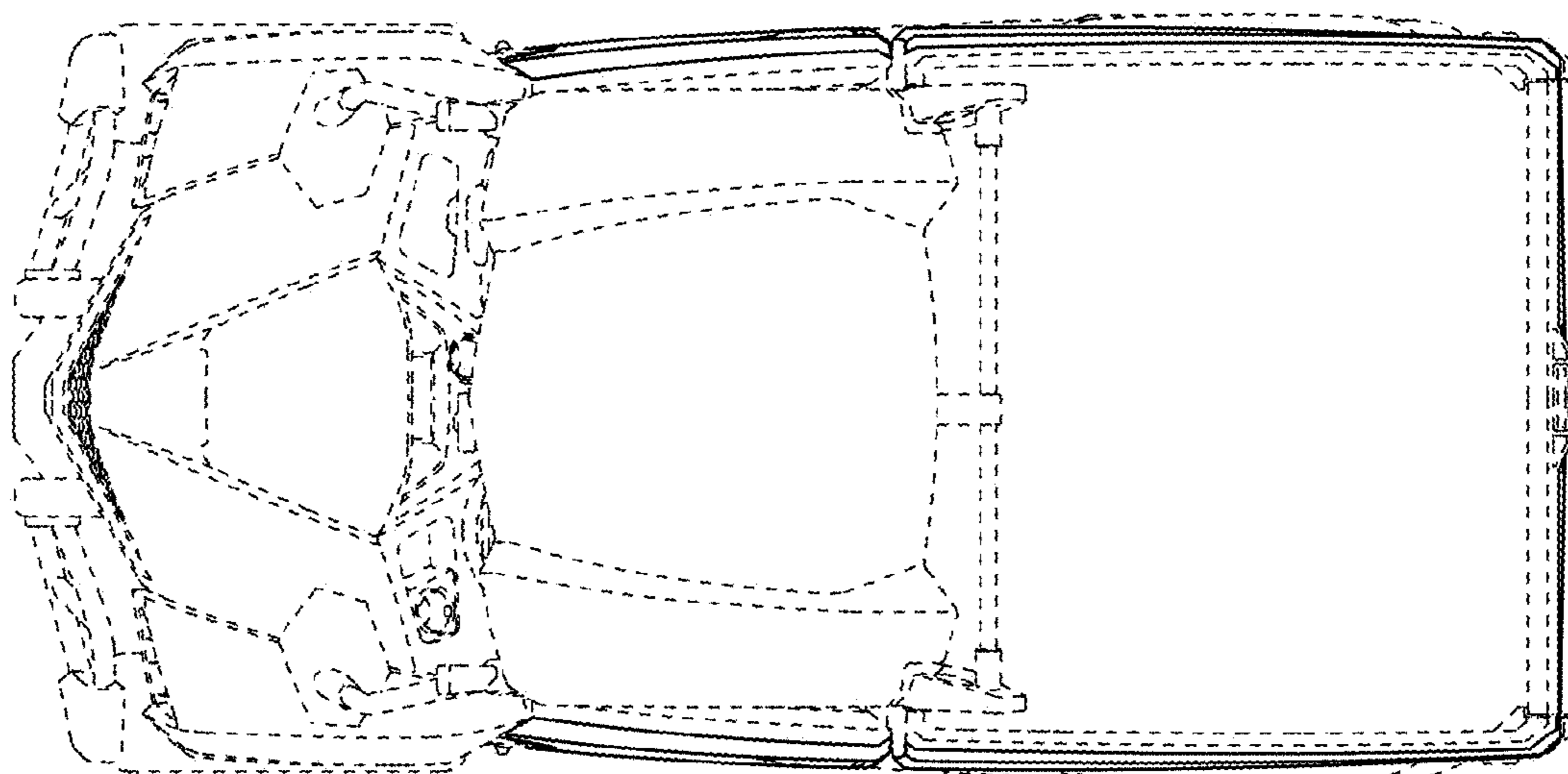

FIG. 4

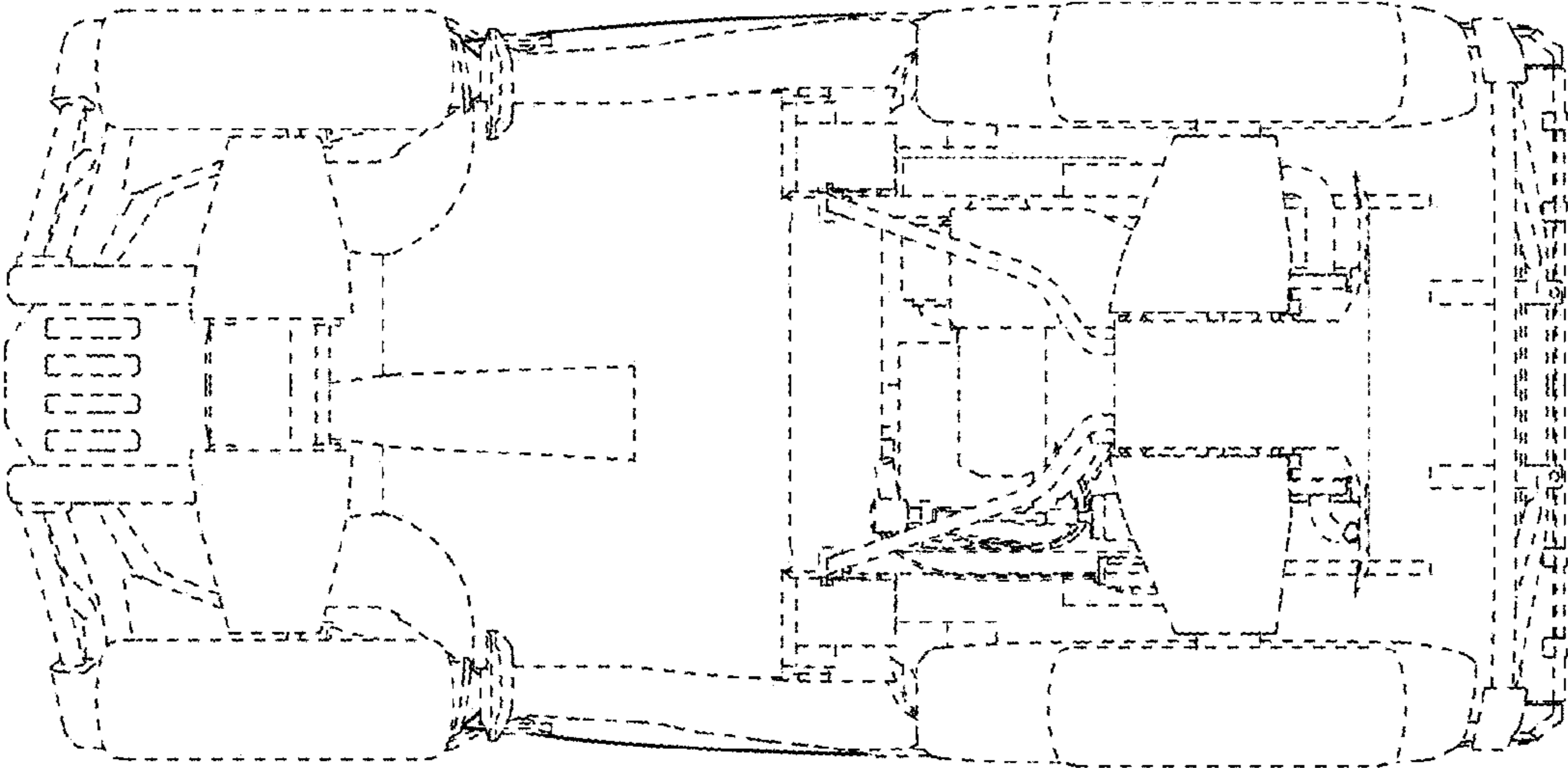

FIG. 5

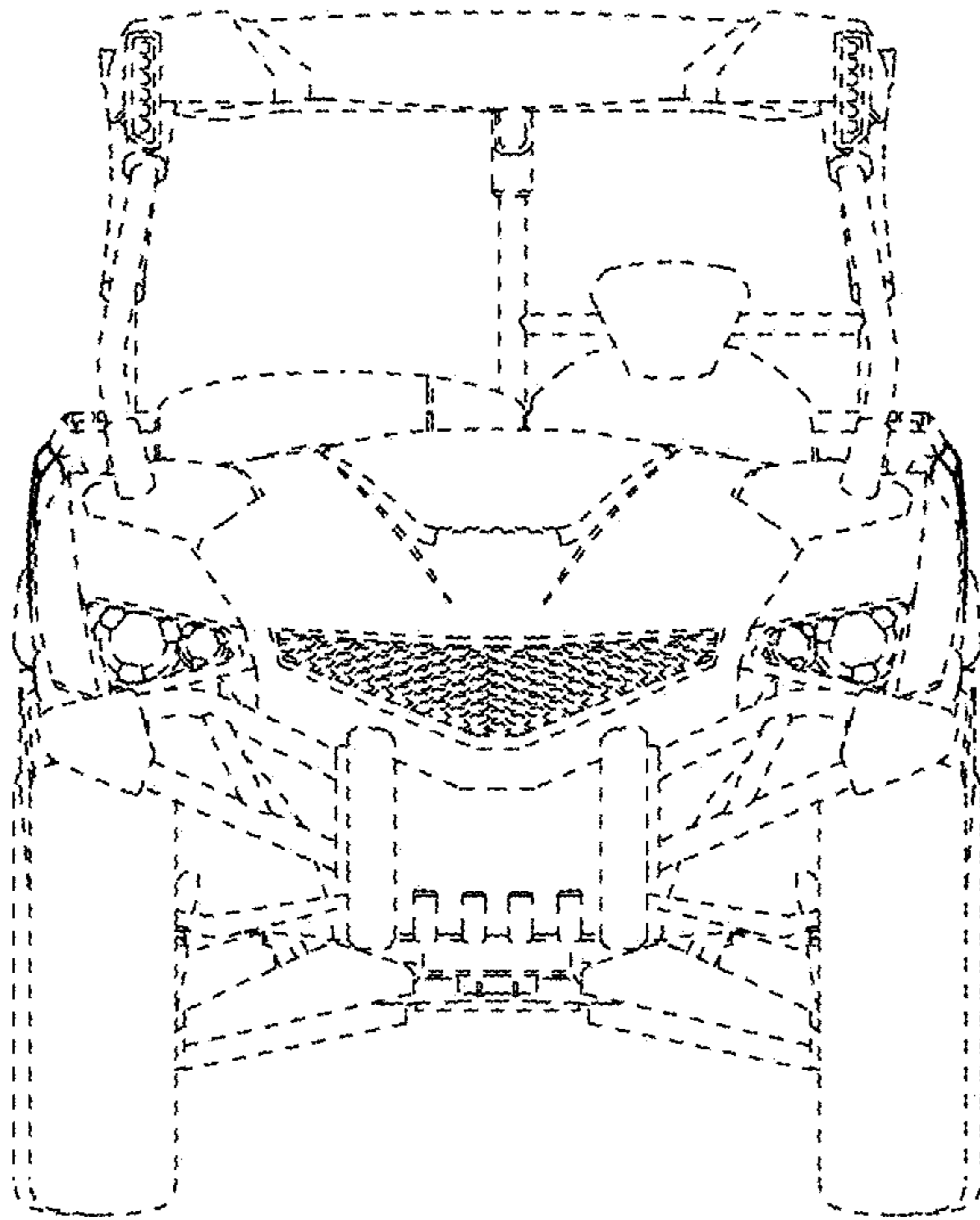

FIG. 6

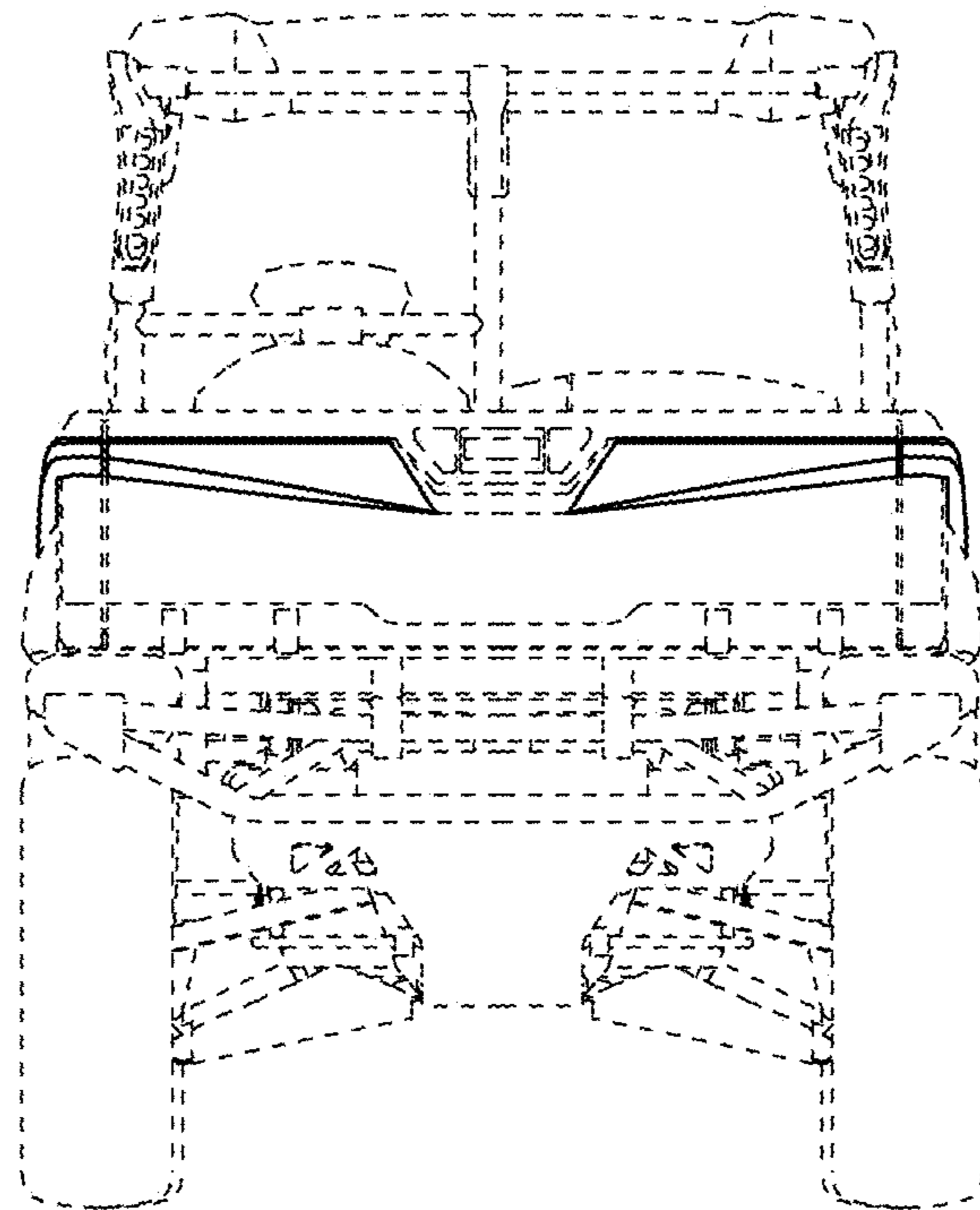

FIG. 7