

US00D763729S

(12) **United States Design Patent**
Martella

(10) **Patent No.:** **US D763,729 S**
(45) **Date of Patent:** **** Aug. 16, 2016**

- (54) **WINE BARREL SCULPTURE**
- (71) Applicant: **Monte Martella**, Livermore, CA (US)
- (72) Inventor: **Monte Martella**, Livermore, CA (US)
- (**) Term: **14 Years**
- (21) Appl. No.: **29/489,809**
- (22) Filed: **May 2, 2014**
- (51) **LOC (10) Cl.** **11-02**
- (52) **U.S. Cl.**
USPC **D11/131**
- (58) **Field of Classification Search**
USPC D11/109, 131–164, 165–183, 184;
D12/193; D20/13, 10, 42; D99/34;
116/173, 174, 209; 40/212, 542;
137/624.12; D25/100, 101, 199;
D6/300, 586, 370, 368, 334–336, 367,
D6/374, 716, 716.1–716.4, 369; 297/16.1,
297/34, 39, 40, 55, 452.63; D26/118
CPC B65D 9/04; B65D 9/30; B65D 7/14
See application file for complete search history.

- D311,953 S * 11/1990 Martinson D23/398
- 5,522,753 A * 6/1996 McGraw A63H 33/18
446/34
- D438,024 S * 2/2001 Catalano D6/349
- D503,241 S * 3/2005 Crosby D26/118
- D516,330 S * 3/2006 Ruitter D6/370
- D544,131 S * 6/2007 Blackman D26/85
- D615,313 S * 5/2010 Rooth D6/370
- D645,682 S * 9/2011 Nakamura D6/716.4
- D663,473 S * 7/2012 Bolton D26/118
- D700,449 S * 3/2014 Romans D6/370
- D700,787 S * 3/2014 VanderKamp D6/370
- D709,709 S * 7/2014 Mareane D6/370
- D712,673 S * 9/2014 Block D6/368
- D736,530 S * 8/2015 Cohen D6/349
- D753,844 S * 4/2016 Gervais D25/100
- D756,263 S * 5/2016 Trigg D11/131

OTHER PUBLICATIONS

Monte Martella Wine Barrel Art (via twitter), available Aug. 2, 2014, [online], [site visited Jan. 28, 2016]. Available from internet, <URL: <https://twitter.com/montemartella/status/495630625081016320>>.*
WinePorn Art, available Nov. 26, 2015, [online], [site visited Jan. 28, 2016]. Available from internet, <URL: <http://socialvignerons.com/2015/11/26/wineporn-art-deconstructed-wine-barrel/>>.*

(Continued)

(56) **References Cited**

U.S. PATENT DOCUMENTS

- 880,042 A * 2/1908 Rietmann B65D 7/14
217/122
- 1,676,319 A * 7/1928 Bolinder B65D 9/04
217/88
- 1,976,173 A * 10/1934 Hutchings B65D 9/04
217/88
- 1,978,811 A * 10/1934 Muller B65D 9/04
217/88
- 1,981,659 A * 11/1934 Muller B65D 9/04
144/346
- D166,418 S * 4/1952 Sandkuhle D11/156
- D166,419 S * 4/1952 Sandkuhle D11/156
- D208,645 S * 9/1967 Kiggins D11/143
- D260,459 S * 9/1981 Lamb D6/368
- 4,792,182 A * 12/1988 McLeod A47C 4/025
297/340

Primary Examiner — Cathron Brooks

Assistant Examiner — Teddy Falloway

(74) *Attorney, Agent, or Firm* — Gerald R Prettyman

(57) **CLAIM**

The ornamental design for a wine barrel sculpture, as shown.

DESCRIPTION

FIG. 1 is a front elevation view of the wine barrel sculpture, showing my new design.

FIG. 2 is a top plan view thereof;

FIG. 3 is an isometric left side view thereof; and,

FIG. 4 is a back elevation view thereof.

1 Claim, 4 Drawing Sheets

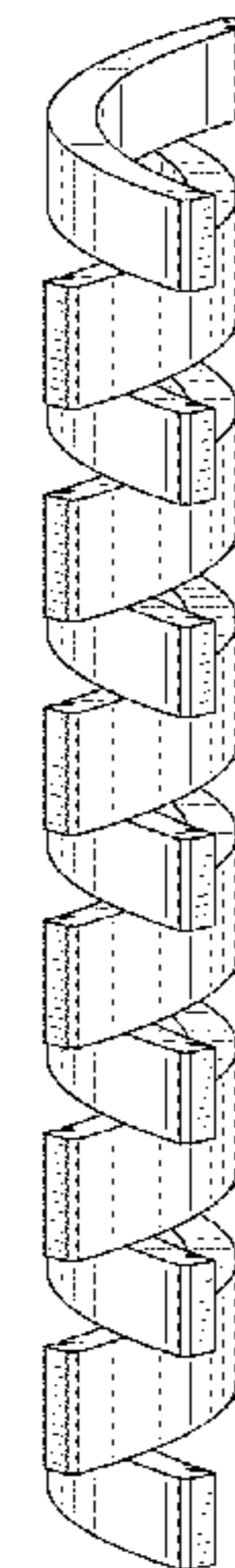
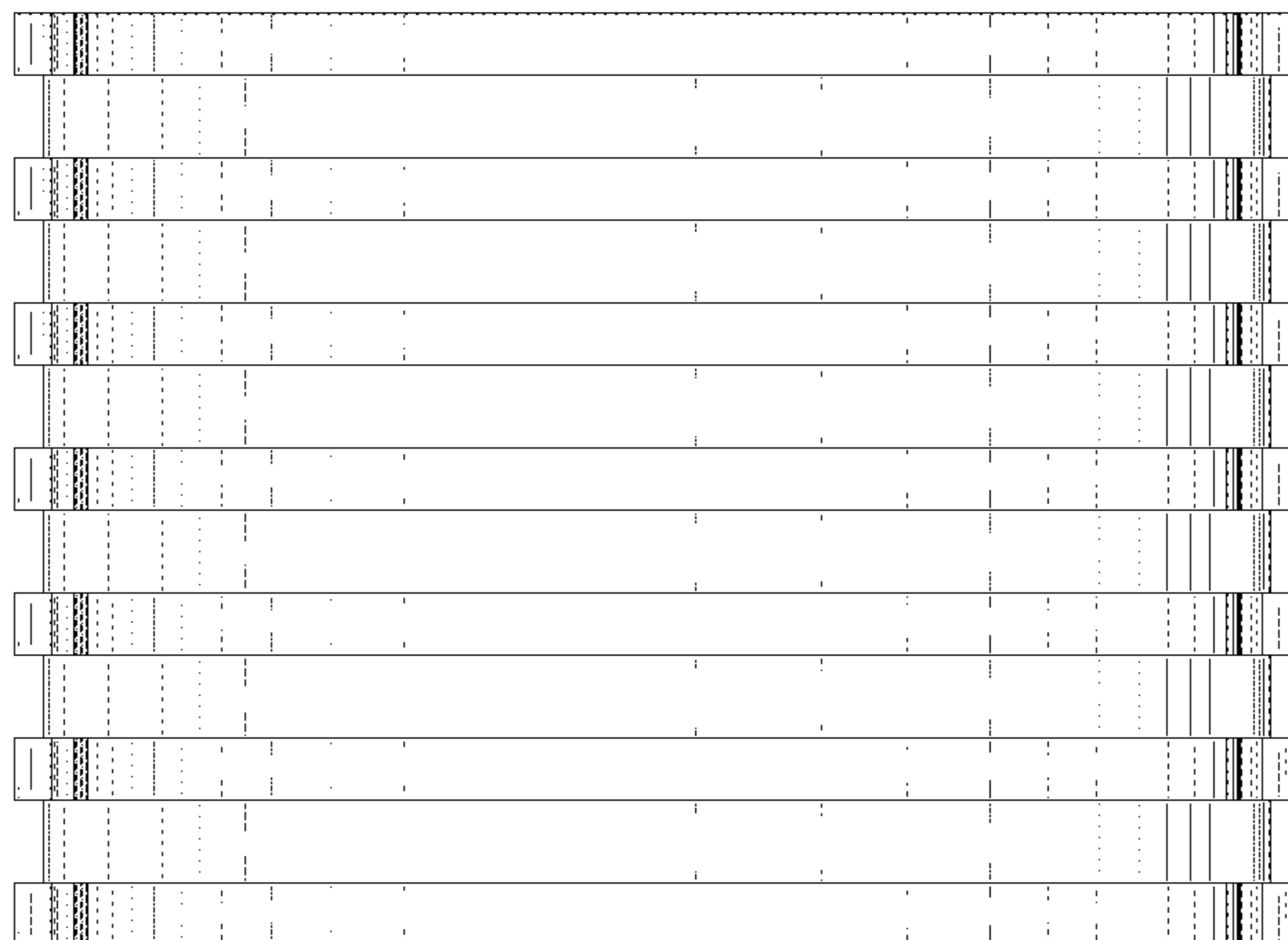

(56)

References Cited

OTHER PUBLICATIONS

Glenfiddich Barrels of Art, available Jan. 12, 2008, [online], [site visited Jan. 28, 2016]. Available from internet, <URL: <http://chapter5section2.blogspot.com/2008/12/glenfiddich-barrels-of-art.html>>.*

Decorative wall (via one hundred eggs blog), available Aug. 3, 2010, [online], [site visited Jan. 28, 2016]. Available from internet, <URL: <http://www.onehundredeggs.com/my-old-kentucky-bourbon-trail-part-ii/>>.*

Kentucky Bourbon Marketplace Bar (via Bourbon Barrel Rehab blog), available Oct. 15, 2013, [online], [site visited Jan. 28, 2016]. Available from internet, <URL: <http://www.bourbonbarrelrehab.com/rehab-notes---blog/bourbon-festival-2013>>.*

Folk Art Stave Flag (via yelp), available Sep. 24, 2015, [online], [site visited Jan. 28, 2016]. Available from internet, <URL: http://www.yelp.com/user_local_photos?select=5YNxc-tjrdYAmKxuaR5fzQ&userid=v5QumKz5Low5jjowd3q81w>.*

Hanging Rack from Barrel Staves, available Jan. 28, 2013, [online], [site visited Jan. 28, 2016]. Available from internet, <URL: <http://www.amazon.com/Hanging-bottle-glass-barrel-staves/dp/B004SCL4O2>>.*

* cited by examiner

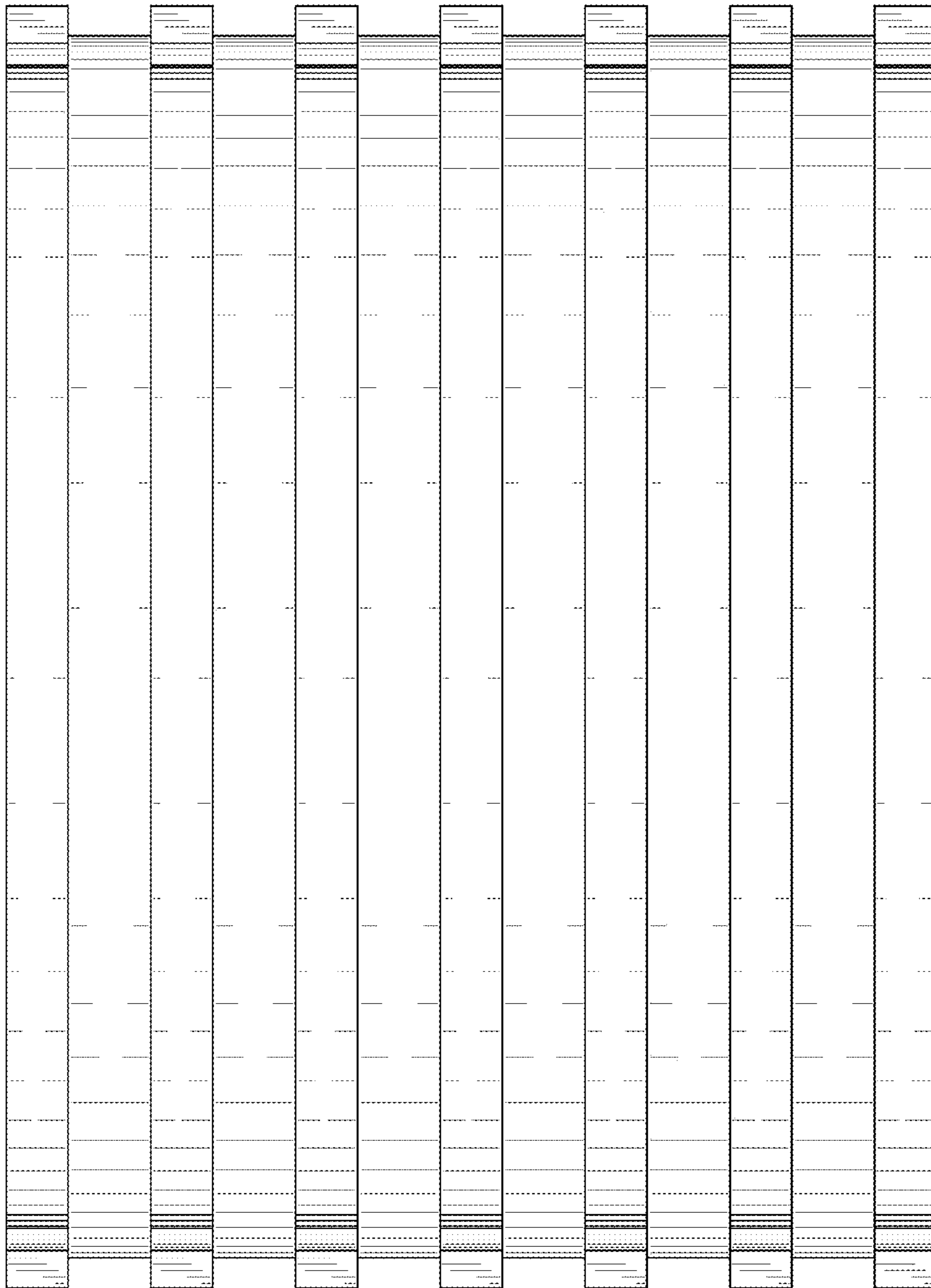

FIG. 1

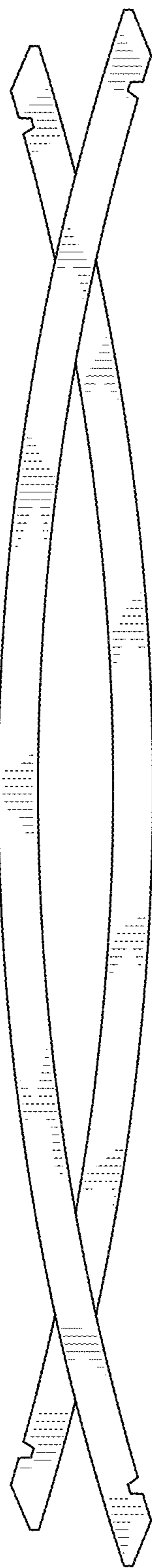

FIG. 2

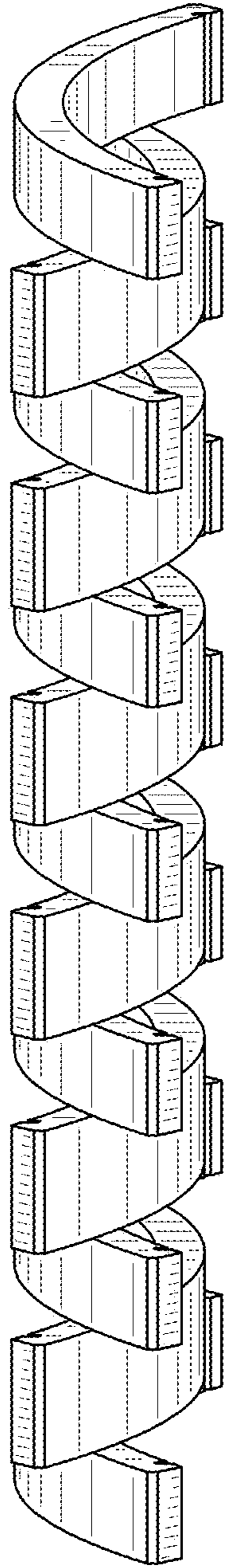

FIG. 3

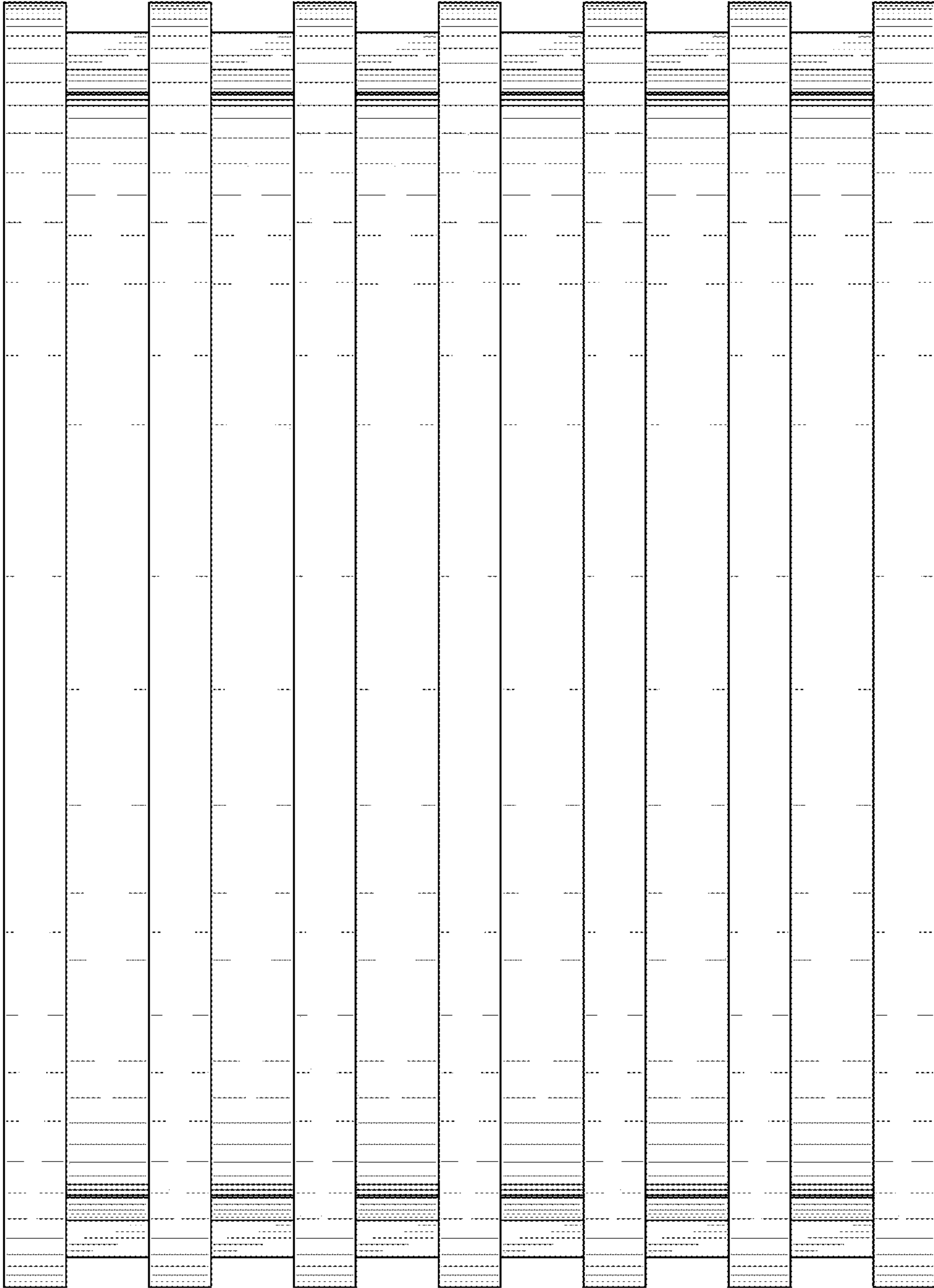

FIG. 4